

Installation, commissioning and servicing instructions

Wall hung RSF gas fired condensing system boiler

Greenstar CDi Classic System ^{ErP}

For central heating systems and indirect fed domestic hot water



The appliance is for use with:
Natural Gas or L.P.G. (CAT II 2H3P type C13 & C33)

Natural Gas:

30CDi Classic System ^{ErP} GC number 41-406-37

35CDi Classic System ^{ErP} GC number 41-406-39

L.P.G.:

30CDi Classic System ^{ErP} GC number 41-406-38

35CDi Classic System ^{ErP} GC number 41-406-40



Contents

1	KEY TO SYMOLS AND SAFETY PRECAUTIONS	3	6	SERVICING AND SPARES	37
1.1	Key to symbols	3	6.1	Inspection and spares	37
1.2	Safety precautions	4	6.1.1	Checking flue integrity	37
<hr/>			6.1.2	Component access	38
2	APPLIANCE INFORMATION	5	6.1.3	Fan pressure test	38
2.1	General information	5	6.1.4	To Clean the Heat Exchanger	40
2.2	Layout & components	6	6.1.5	To Clean the Burner	40
2.3	Technical data	8	6.1.6	To Check the Diaphragm in Burner Cover	41
2.4	Product data on energy consumption	9	6.1.7	To Clean the Siphon/Condensate Trap	41
<hr/>			6.2	Setting the air/gas ratio	41
3	PRE-INSTALLATION	10	6.3	Replacement of parts	42
3.1	Cleaning primary systems	10	6.4	Short parts list	51
3.2	Mains supply	10	<hr/>		
3.2.1	Gas supply	10	7	FAULT FINDING & DIAGNOSIS	52
3.3	Water systems & pipe work	10	7.1	Fault finding	52
3.4	Condensate discharge	11	7.2	Central heating function	53
3.4.1	Appliance siphonic condensate trap	11	7.3	Cylinder heat function	54
3.4.2	Condensate pipe work	11	7.4	Protection function	55
3.4.3	Internal connections	12	<hr/>		
3.4.4	External connections	12			
3.5	Boiler internal drain	14			
3.6	Pressure relief pipe work	14			
3.7	Boiler location & clearances	14			
3.8	Plumbing manifold	16			
3.9	Flue options	17			
3.10	Flue terminal positions	19			
3.11	Plume management terminal positions	20			
<hr/>					
4	INSTALLATION	21			
4.1	Unpacking wall frame and ancillary items	21			
4.2	Wall mounting plate and flue opening	22			
4.3	Unpacking the appliance	23			
4.4	Fitting the appliance/boiler connections	24			
4.5	Flue installation	25			
4.5.1	Ø 60/100 mm Telescopic flue kit	25			
4.5.2	Ø 60 mm Plume management kit	25			
4.5.3	Adjusting the standard terminal length:	25			
4.5.4	Installing the standard flue	26			
4.5.5	Flue terminal plume re-direction:	26			
4.6	Condensate connection	27			
4.7	Electrical (without diverter valve)	28			
4.8	Electrical (with optional diverter valve)	29			
4.9	Position of wired components	30			
<hr/>					
5	COMMISSIONING	31			
5.1	Pre-commissioning checks	31			
5.2	Filling the system	31			
5.3	Starting the appliance	32			
5.4	Water treatment	32			
5.5	Commissioning	33			
5.5.1	Checking the gas inlet pressure	33			
5.5.2	Checking the gas rate	34			
5.6	CO and Combustion checks	35			
5.7	Finishing commissioning	36			

1 KEY TO SYMOLS AND SAFETY PRECAUTIONS

1.1 Key to symbols

Warnings

	Warnings in this document are identified by a warning triangle printed against a grey background. Keywords at the start of a warning indicate the type and seriousness of the ensuing risk if measures to prevent the risk are not taken.
---	---

The following keywords are defined and can be used in this document:

- **NOTE** indicates a situation that could result in damage to property or equipment.
- **CAUTION** indicates a situation that could result in minor to medium injury.
- **WARNING** indicates a situation that could result in severe injury or death.
- **DANGER** indicates a situation that will result in severe injury or death.

Important information

	This symbol indicates important information where there is no risk to people or property.
---	---

Additional symbols

Symbol	Explanation
▶	Step in an action sequence
→	Cross-reference to another part of the document
•	List entry
–	List entry (second level)

Table 1

SYMBOLS USED IN THIS MANUAL







	Domestic Hot Water
	Central Heating
	Hot Water Storage Cylinder
	Domestic Cold Water Supply
	Electrical Supply
	Gas Supply

Table 2 Commonly used symbols

PLEASE READ THESE INSTRUCTIONS CAREFULLY BEFORE STARTING INSTALLATION.

These instructions are applicable to the Worcester appliance model(s) stated on the front cover of this manual only and must not be used with any other make or model of appliance.

These instructions apply in the UK and Ireland only and must be followed except for any statutory obligations.

This appliance must be installed by a **GAS SAFE** registered, competent person. Failure to install correctly could lead to prosecution.

If you are in any doubt, contact the Worcester Technical helpline (0330 123 3366).

Please leave these instructions with the completed BENCHMARK CHECKLIST, (or a certificate confirming compliance with IS 813, Eire only) and the user manual with the owner or at the gas meter after installation or servicing.

Distance learning and training courses are available from Worcester.

The BENCHMARK CHECKLIST can be found in the back of this Installation manual.

Table 3

∅	Diameter
NG	Natural Gas
LPG	Liquid Petroleum Gas
CH	Central Heating
DHW	Domestic Hot Water
DCW	Domestic Cold Water
PRV	Pressure Relief Valve
NTC	Negative Temperature Coefficient (sensor)
IP	Ingress Protection
RCD	Residual Current Device
TRV	Thermostatic Radiator Valve
ECV	Emergency Control Valve
WRAS	Water Regulations Advisory Scheme
SEDBUK	Seasonal Efficiency of Domestic Boilers in the United Kingdom

Table 4 Abbreviations use in this manual

1.2 Safety precautions

If you smell gas

A gas leak could potentially cause an explosion. If you smell gas, observe the following rules.

- ▶ Prevent flames or sparks:
 - Do not smoke, use a lighter or strike matches.
 - Do not operate any electrical switches or unplug any equipment.
 - Do not use the telephone or ring doorbells.
- ▶ Turn off the gas at the meter.
- ▶ Open windows and doors.
- ▶ Warn your neighbours and leave the building.
- ▶ Prevent anyone from entering the building.
- ▶ Well away from the building: call the National Gas Emergency Service on 0800 111 999.

BOILER OPERATION:

This boiler must only be operated by a responsible adult who has been instructed in, understands and is aware of the boiler's operating conditions and effects.



Benchmark places responsibilities on both manufacturers and installers. The purpose is to ensure that customers are

provided with the correct equipment for their needs, that it is installed, commissioned and serviced in accordance with the manufacturer's instructions by competent persons and that it meets the requirements of the appropriate Building Regulations. The Benchmark Checklist can be used to demonstrate compliance with Building Regulations and should be provided to the customer for future reference.

Installers are required to carry out installation, commissioning and servicing work in accordance with the Benchmark Code of Practice which is available from the Heating and Hotwater Industry Council who manage and promote the scheme.

Visit centralheating.co.uk for more information.

HEALTH AND SAFETY

The appliance contains no asbestos and no substances have been used in the construction process that contravene the COSHH Regulations (Control of Substances Hazardous to Health Regulations 1988).

COMBUSTIBLE AND CORROSIVE MATERIALS:

Do not store or use any combustible materials (paper, thinners, paints etc.) inside or within the vicinity of the boiler.

Chemically aggressive substances can corrode the appliance and invalidate any warranty.

FITTING & MODIFICATIONS

Fitting the appliance and any controls to the appliance may only be carried out by a competent engineer in accordance with the current Gas Safety (Installation and Use) Regulations.

Flue systems must not be modified in any way other than as described in the fitting instructions. Any misuse or unauthorised modifications to the appliance, flue or associated components and systems could invalidate the warranty. The manufacturer accepts no liability arising from any such actions, excluding statutory rights.

SERVICING

Advise the user to have the system serviced annually by a competent, qualified Gas Safe registered engineer. Approved spares must be used to help maintain the economy, safety and reliability of the appliance.

IMPORTANT

The service engineer must complete the Service Record on the Benchmark Checklist after each service.

INSTALLATION REGULATIONS

Current Gas Safety (Installation & Use) Regulations:

All gas appliances must be installed by a competent person in accordance with the above regulations. Failure to install appliances correctly could lead to prosecution.

The appliance must be installed in accordance with, and comply to, the current: Gas Safety Regulations, IET Regulations, Building Regulations (England), Building Standards (Scotland) (Consolidation), Building Regulations (Wales), Building Regulations (Northern Ireland), local water by-laws, Health & Safety Document 635 (The Electricity at Work Regulations 1989) and any other local requirements.

EU Regulations No. 811/2013 - Energy Labelling.

British Standards:

Where no specific instruction is given, reference should be made to the relevant British Standard codes of Practice.

BS7074:1 - Code of practice for domestic and hot water supply

BS6891 - Installation of low pressure gas pipe work up to 28mm (R1)

BS5546 - Installation of gas hot water supplies for domestic purposes

EN12828 - Central heating for domestic premises

BS5440:1 - Flues and ventilation for gas appliances of rated heating not exceeding 70kW (net): Flues

BS5440:2 - Flues and ventilation for gas appliances of rated heating not exceeding 70kW (net): Air Supply

BS7593 - Treatment of water in domestic hot water central heating systems

BS6798 - Installation of gas fired boilers of rated input up to 70kW (net)

Irish Standards

The relevant Irish standards should be followed, including:

- ECTI National rules for electrical installations
- IS 813:2002 for Domestic Gas Installations.

LPG Installations

An appliance using L.P.G. must not be installed in a room or internal space below ground level unless one side of the building is open to the ground.

Timber framed building:

Where the boiler is to be fitted to a timber framed building the guidelines laid down in BS5440: Part 1 and IGE "Gas Installations in Timber Frame Buildings" should be adhered to.

Potable water:

All seals, joints and compounds (including flux and solder) and components used as part of the secondary domestic water system must be approved by WRAS.

CH Water:

Artificially softened water must not be used to fill the central heating system.

2 APPLIANCE INFORMATION

2.1 General information

BOILER FEATURES

- Pre-wired and pre-plumbed
- Galvanised steel inner frame
- Digital control system
- FX/Greenstar Sense intelligent controls*
- Automatic ignition
- Direct burner ignition electrodes
- Built-in frost protection
- Built-in fault finding diagnostics
- Modulating automatic gas valve
- Combustion air fan with speed regulator
- CH temperature sensor & control
- Pump anti-seizure protection
- Flue gas temperature sensor
- Condensate siphonic trap
- Low Energy Modulating pump

* If the optional integral diverter valve kit is fitted.

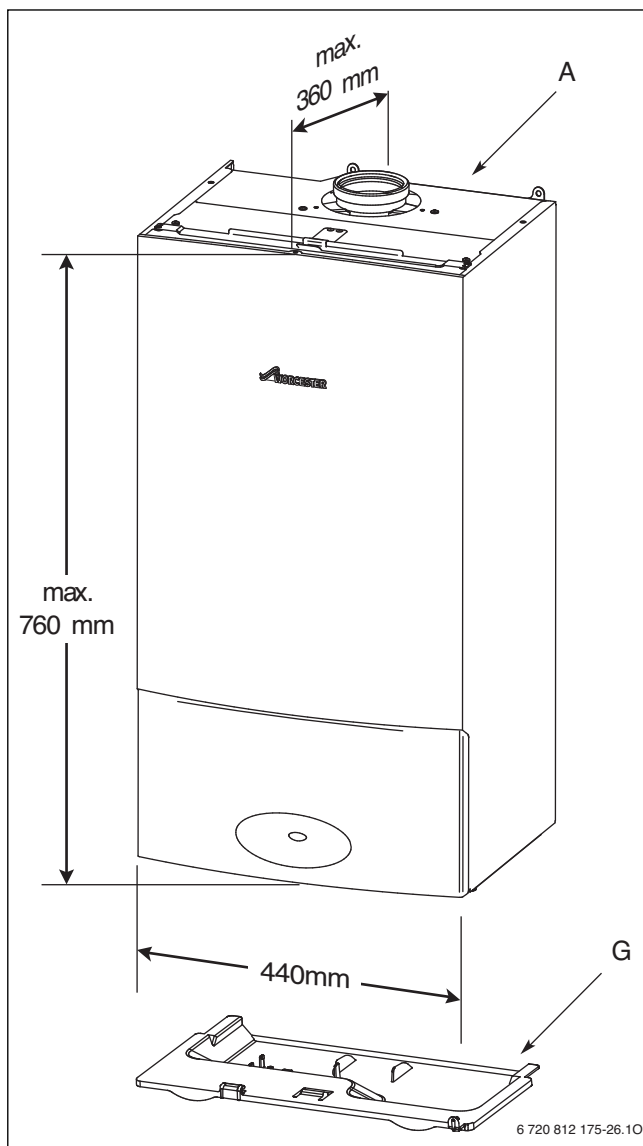

Fig. 1 Overall dimensions

STANDARD PACKAGE:

A	Wall hung gas fired condensing system boiler for central heating and domestic hot water
B	Wall mounting plate with hanging bracket
C	Pre-plumbing manifold
D	Hardware pack
E	Literature pack
	- Installation instructions
	- User instructions
	- Wall mounting template
F	ErP energy label
G	Bottom panel

Table 5

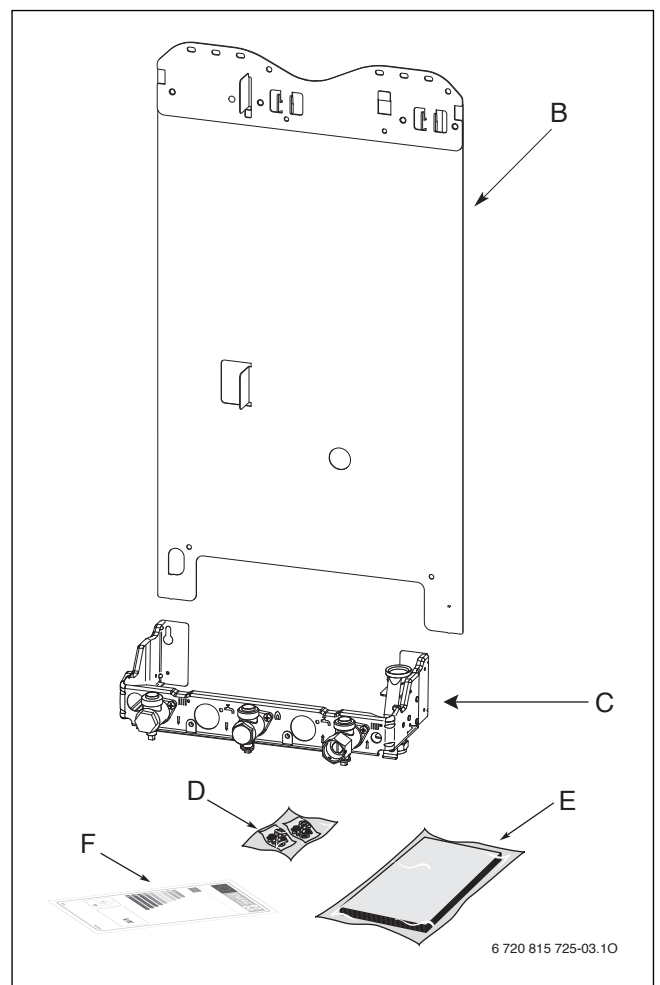
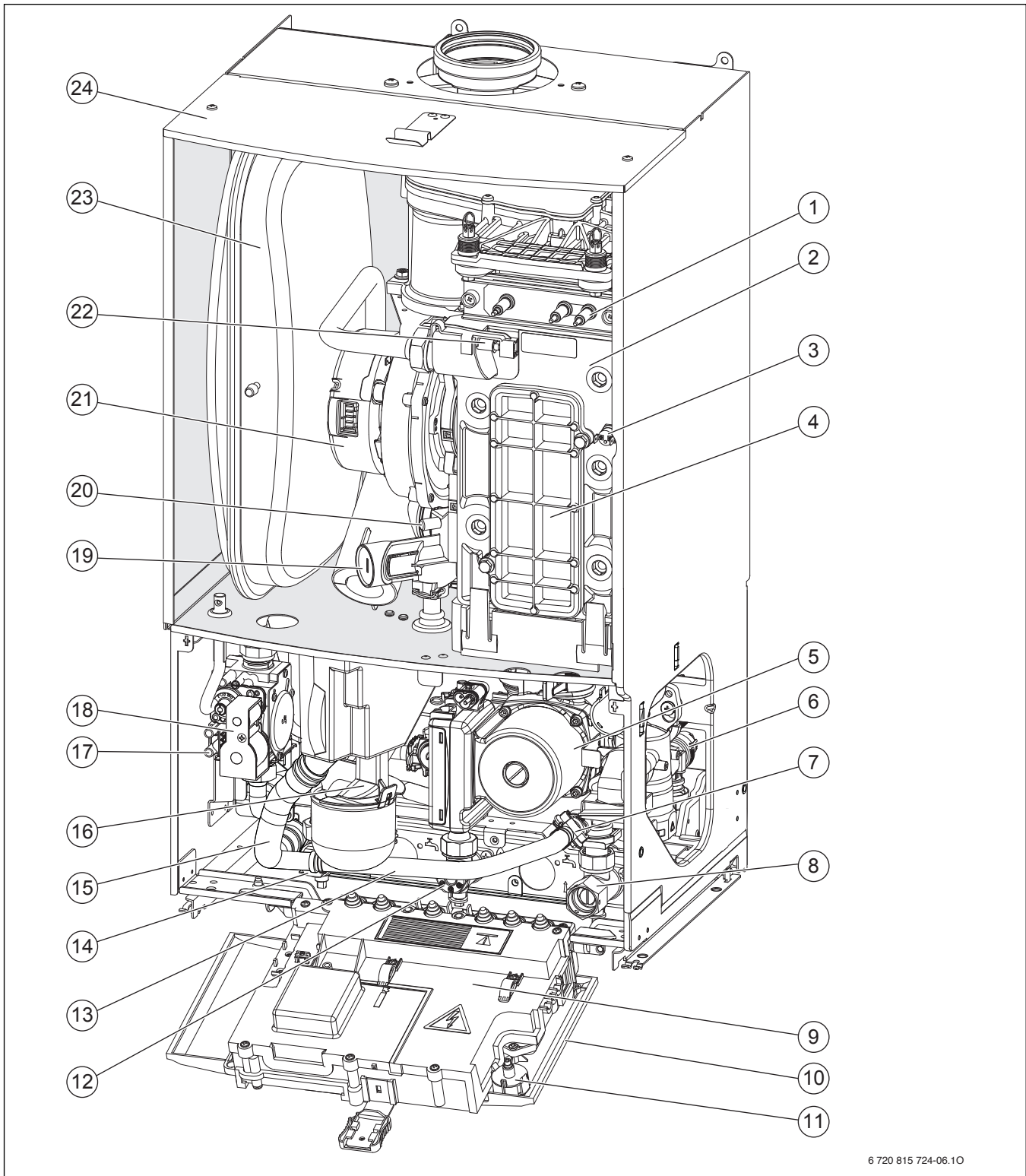

Fig. 2 Standard package

2.2 Layout & components



6 720 815 724-06.10

Fig. 3 Controls in the servicing position excluding the outer case

1	Ignition electrode and flame sense
2	Heat exchanger
3	Overheat thermostat
4	Access point for cleaning heat exchanger
5	Low Energy Modulating pump
6	Pressure relief valve
7	Boiler drain point
8	CH return
9	Cover for external wiring connections
10	Control panel in service position
11	System pressure gauge
12	Gas inlet connection 22mm compression
13	Drain hose
14	CH flow
15	Condensate hose (22 mm outlet connection)
16	Trap/Siphon outlet
17	Inlet pressure test point
18	Gas valve
19	Air/Gas adjustment screw
20	Fan pressure test point
21	Fan
22	Primary sensor
23	Expansion vessel
24	Removable panel for servicing

Table 6 Main boiler components

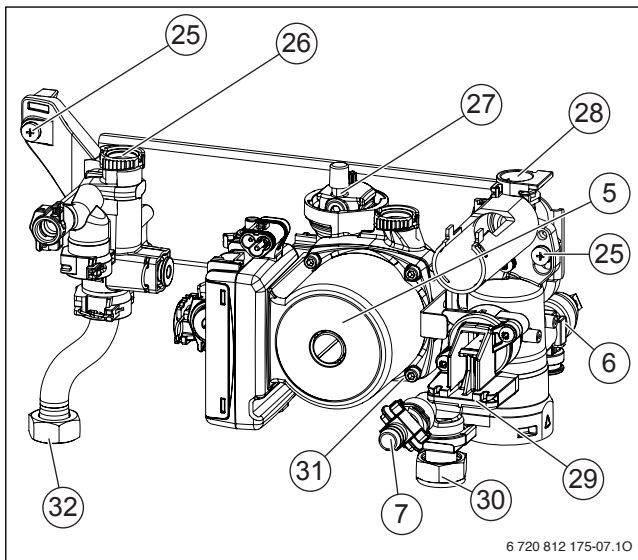

Fig. 4 Hydraulics

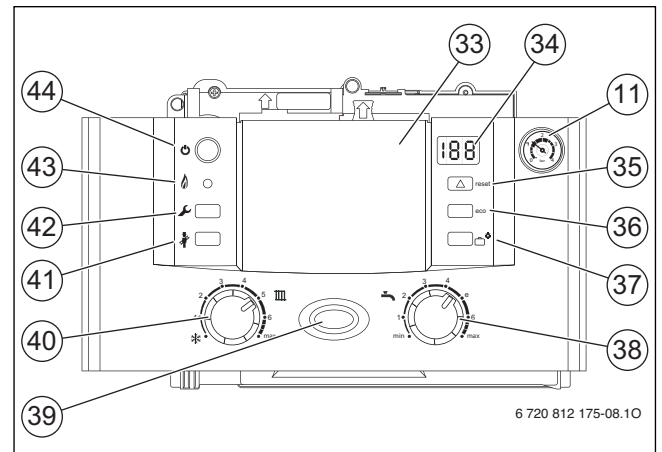

Fig. 5 Control panel

25	Compact hydraulic mounting screw (2) to boiler
26	Flow connection from boiler heat exchanger
27	Auto air vent
28	Unused port
29	Optional integral diverter valve position
30	Return connection to service valve
31	Internal bypass within plastic moulding
32	Flow connection to service valve
33	Position for optional control
34	Display
35	Fault reset button
36	ECO button (only in conjunction with optional diverter valve)
37	Holiday button (only in conjunction with optional diverter valve)
38	DHW Temperature control (only in conjunction with optional diverter valve)
39	Mains ON/OFF Indicator/Diagnostic light (blue)
40	CH Temperature control
41	Performance test button
42	Service button
43	Burner ON indicator light (green)
44	Master switch ON/OFF

Table 7 Hydraulics and control panel

2.3 Technical data

Product type		NATURAL GAS	L.P.G.	NATURAL GAS	L.P.G.
		30CDi Classic System ^{ErP}	30CDi Classic System ^{ErP}	35CDi Classic System ^{ErP}	35CDi Classic System ^{ErP}
Domestic hot water					
Min. heat input	kW	8.0	11.5	8.0	11.5
Max. rated heat output	kW	30.9	30.9	35.0	35.0
Max. rated heat input	kW	30.9	30.9	35.0	35.0
Domestic Hot Water temperature range	°C	40-70	40-70	40-70	40-70
Central Heating					
Max. rated heat input	kW	30.9	30.9	35.0	35.0
Max. rated heat output net 40/30°C	kW	32.1	32.1	36.4	36.4
Max. rated heat output net 50/30°C	kW	31.8	31.8	36.1	36.1
Max. rated heat output net 80/60°C	kW	30.0	30.0	34.0	34.0
Min. rated heat output net 40/30°C	kW	8.6	12.4	8.6	12.4
Min. rated heat output net 50/30°C	kW	8.6	12.3	8.6	12.3
Min. rated heat output net 80/60°C	kW	7.7	11.0	7.7	11.0
Min. rated heat input net	kW	8.0	11.5	8.0	11.5
Max. flow temperature	°C	nom. 90	nom. 90	nom. 90	nom. 90
Max. permissible operating pressure	bar	2.5	2.5	2.5	2.5
Available pump head at 21°C system temperature rise	m	2	2	2	2
Gas flow rate - Max. 10 minutes from lighting					
Natural Gas G20	m ³ /h	3.2		3.7	
Propane Gas (LPG)	kg/h		2.4		2.7
Flue					
Flue Gas Temp. 80/60°C, rated min. load Max/Min	°C	76/58	76/58	81/58	81/58
Flue Gas Temp. 40/30°C, rated min. load Max/Min	°C	55/33	55/33	58/33	58/33
CO ₂ level at max. rated heat output	%	9.6	11.5	9.6	11.5
CO ₂ level at min. rated heat output	%	9.0	10.5	9.0	10.5
NO _x - class		5	5	5	5
Condensate					
Max. condensation rate	l/h	2.7	2.7	2.7	2.7
pH value, approx.		4.8	4.8	4.8	4.8
Electrical					
Electrical power supply voltage	AC... V	230	230	230	230
Frequency	Hz	50	50	50	50
Max. power consumption	W	120	120	130	130
Energy efficiency index (EEI) heating pump	-	≤ 0,23	≤ 0,23	≤ 0,23	≤ 0,23
General Data					
SEDBUK	band	A	A	A	A
Appliance protection rating	IP	X4D	X4D	X4D	X4D
Appliance protection rating with mechanical or RF mech. timer fitted	IP	20	20	20	20
Permissible ambient temperatures	°C	0-50	0-50	0-50	0-50
Nominal capacity of appliance	l	3.75	3.75	3.75	3.75
Total boiler weight (lift weight)	kg	46.5	46.5	46.5	46.5
Packaged boiler weight	kg	54	54	54	54
SAP 2009 annual efficiency	%	89.2	90.2	89.2	90.2
SAP 2005 seasonal efficiency (SEDBUK)	%	90.2	92.1	90.1	92.0

Table 8 Technical data

2.4 Product data on energy consumption

The following product data satisfy the requirements of the EU Regulations No. 811/2013, No. 812/2013, No. 813/2013 and No. 814/2013 supplementing Directive 2010/30/EU.

Product data	Symbol	Unit	7 738 100 244	7 738 100 233	7 738 100 236	7 738 100 237
Product type	–	–	30CDi Classic System ^{ErP}	30CDi Classic System ^{ErP} LPG	35CDi Classic System ^{ErP}	35CDi Classic System ^{ErP} LPG
Condensing boiler	–	–	Yes	Yes	Yes	Yes
Rated heat output	P_{rated}	kW	30	30	34	34
Seasonal space heating energy efficiency	η_s	%	92	92	92	92
Energy efficiency class	–	–	A	A	A	A
Useful heat output						
At rated heat output and high temperature regime ¹⁾	P_4	kW	30.0	30.0	34.0	34.0
At 30 % of rated heat output and low temperature regime ²⁾	P_1	kW	10.0	10.0	11.4	11.4
Useful efficiency						
At rated heat output and high temperature regime ¹⁾	η_4	%	88.2	88.2	88.2	88.2
At 30 % of rated heat output and low temperature regime ²⁾	η_1	%	97.5	97.5	97.5	97.5
Auxiliary electricity consumption						
At full load	e_{max}	kW	0.058	0.058	0.058	0.058
At part load	e_{min}	kW	0.030	0.030	0.030	0.030
In standby mode	P_{SB}	kW	0.004	0.004	0.004	0.004
Other items						
Standby heat loss	P_{stby}	kW	0.048	0.048	0.048	0.048
Emissions of nitrogen oxides	NOx	mg/kWh	30	30	30	30
Sound power level, indoors	L_{WA}	dB(A)	55	55	58	58

Table 9 Product data for energy consumption

- 1) High temperature regime means 60 °C return temperature at heater inlet and 80 °C feed temperature at heater outlet.
- 2) Low temperature means for condensing boilers 30 °C, for low-temperature boilers 37 °C and for other heaters 50 °C return temperature (at heater inlet).

3 PRE-INSTALLATION

3.1 Cleaning primary systems

CAUTION: MAINS SUPPLIES

- ▶ Isolate the mains supplies before starting any work and observe all relevant safety precautions.

NOTICE: Before installation

- ▶ All the following Pre-Installation sections must be read and requirements met before starting boiler or flue installations.

NOTICE: Water treatment

- ▶ Debris from the system can damage the boiler and reduce efficiency. Failure to comply with the guidelines for the use of water treatment with the appliance will invalidate the appliance warranty.

BEFORE CLEANING THE SYSTEM:

- ▶ **Ensure that the system and pipe work is in good working order.**
- ▶ **Where possible keep the existing boiler/circulating pump in place when flushing the system.**

FOLLOW THE GUIDANCE OF BS7593:

Treatment of water in domestic hot water central heating and also the flushing guidelines below.

NOTICE: ARTIFICIALLY SOFTENED WATER MUST NOT BE USED TO FILL THE CENTRAL HEATING SYSTEM.
FLUSHING THE SYSTEM

- ▶ Fill the system with cold water and check for leaks.
- ▶ Open all drain cocks and drain the system.
- ▶ Close drain cocks and add a suitable flushing agent **compatible with aluminium** at the correct strength for the system conditions in accordance with the manufacturer's instructions.
The pH value of the system water must be less than 8 or the appliance guarantee will be invalidated.
- ▶ Circulate the flushing agent before the boiler is fired up.
- ▶ Run the boiler/system at normal operating temperature as directed by the manufacturer of the flushing agent.
- ▶ Drain and thoroughly flush the system to remove the flushing agent and debris.
- ▶ It may be necessary to use a power flushing machine to aid the cleansing procedure in some circumstances.
- ▶ Close the drain cocks and refill with fresh water and a suitable inhibitor.
- ▶ Vent any air from the boiler and system.

INHIBITOR

Add a suitable inhibitor or combined inhibitor/anti-freeze, if the system is exposed to freezing conditions, to the heating system in accordance with the DWTA code of practice and manufacturer's guidelines.

WARNING: Sealing agents

- ▶ The addition of sealing agents to the system water is not permitted as this can cause problems with deposits left in the heat exchanger.

Water treatment products

Suitable water treatment products can be obtained from the following manufacturers:

FERNOX	0870 601 5000 www.fernox.com
SENTINEL	0800 389 4670 www.sentinel-solutions.net

Table 10

3.2 Mains supply

3.2.1 Gas supply

To ensure that the equipment is in good working order and can meet the gas flow and pressure requirements, in addition to the demand from any other appliance being served, the following applies:

- Boilers using Natural Gas (NG) must be connected to a governed meter.
- Liquid Petroleum Gas (LPG) must be connected to a regulator.
- Installation and connection of the gas supply to the boiler must be in accordance with BS6891.
- Gas pipe sizing should be calculated to ensure no more than the permitted mbar drop between the meter/governor to the appliance inlet. (→ Commissioning section)
- The meter or regulator and pipe work to the meter must be checked, preferably by the gas supplier.

3.3 Water systems & pipe work

PLASTIC PIPE WORK:

- Any plastic pipe work must have a polymeric barrier with 600 mm (minimum) length of copper or steel pipe connected to the boiler.
- Plastic pipe work used for underfloor heating must be correctly controlled with a thermostatic blending valve limiting the temperature of the circuits to approx. 50°C.
The pipe work from the boiler to the blending valve must be in copper or steel (protected from corrosion).

CONNECTIONS/VALVES:

- All system connections, taps and mixing valves must be capable of sustaining a pressure up to 3 bar.
- Radiator valves should conform to BS2767:10.
- All other valves should conform to BS1010
- On new installations, or extensions to existing systems where a radiator previously did not exist, each radiator should be fitted with a TRV, except the one fitted in the same room/area as the thermostat.
- On boiler only replacement jobs, it is recommended, (but not mandatory,) to fit a TRV on each radiator.
- An automatic bypass may be required, (downstream of the pump), in order to maintain the minimum flow-rate through the appliance.
- A drain cock is required at the lowest point on the system.
- An air vent is required at the highest point on the system.

A - Diverter Valve

B - Automatic Bypass

C - Radiator Valve (Flow)

D - Lockshield Valve (Return)

E - Extra expansion Vessel

- The sealed system must be filled using a WRAS approved filling loop or comply with the diagram opposite for System fill
- Where the system volume is more than 100 litres or exceeds 2.65 bar at maximum heating temperature an extra expansion vessel (E) must be fitted as close as possible to the appliance in the central heating return.
- Pressurize the extra expansion vessel (E) to the same figure as the expansion vessel built into the appliance
- Do not use galvanised pipes or radiators.

- A drain cock is required at the lowest point on the system.

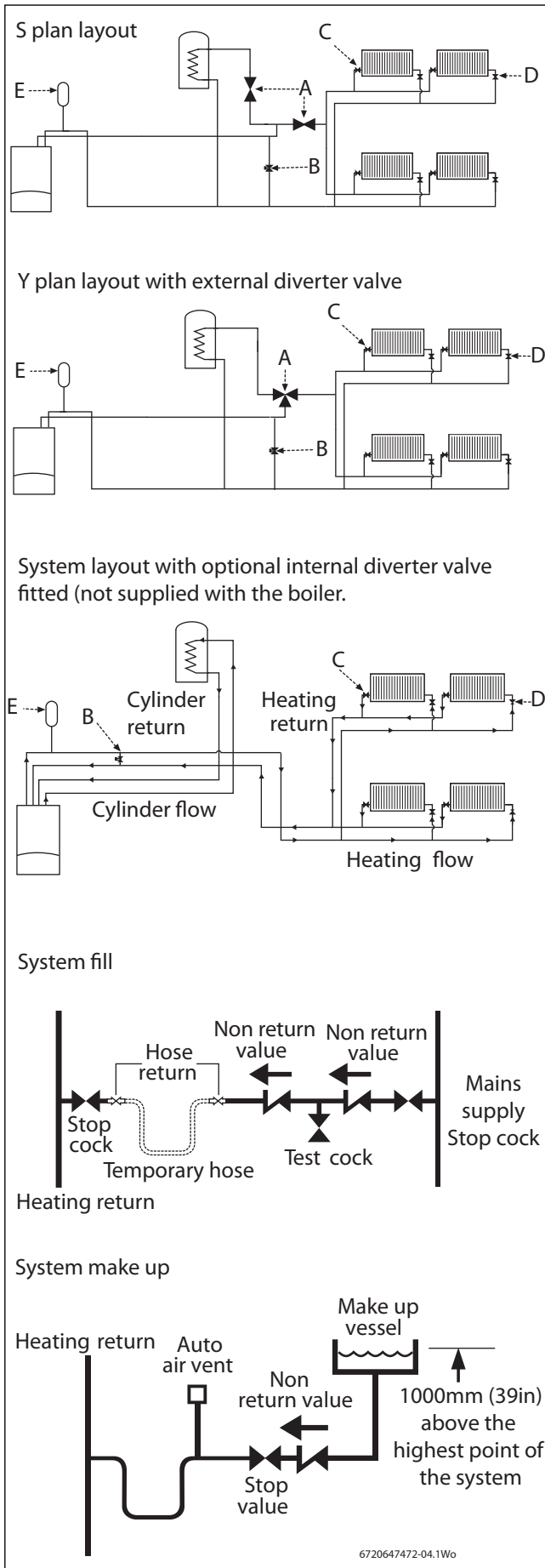

Fig. 6

3.4 Condensate discharge

3.4.1 Appliance siphonic condensate trap

The appliance has a large capacity siphonic condensate trap reducing the risk of condensate discharge freezing up in prolonged cold temperatures.

Like the CondenseSure siphon accessory, the expanded siphonic operation discharges every 15 to 20 minutes, resulting in:

- Increased velocity and flow rate.
- With only 3 to 4 siphonic actions per hour, the condensate pipework is empty for longer.
- Eliminated freezing potential.
 - For a 48 hour period at -15 °C provided the installation parameters listed below are adhered to.

To maximise the effectiveness of this product the installer should:

- Keep the external pipework as short as possible and not exceed 3m.
 - External run pipe diameter should be increased to a minimum of 32mm.
- Ensure a fall of at least 2.5° over horizontal sections.
- Minimise the number of bends and connectors.
- Remove burrs after cutting pipe.
- Remove surplus solvent from the interior of the pipe.

3.4.2 Condensate pipe work

NOTICE:

- ▶ Where a new or replacement appliance is being installed, access to an internal “gravity discharge” point should be one of the factors considered in determining appliance location.
- ▶ The condensate pipe must be nominally 22mm Ø plastic pipe.
- ▶ The condensate pipe work must fall at least 52mm per metre towards the outlet and should take the shortest practicable route.
- ▶ Ensure there are no blockages in the pipe run.

NOTICE: Unheated internal areas.

Although the large volume siphon will reduce the risk of freezing, condensate discharge may freeze in areas of prolonged cold temperatures.

- ▶ Internal pipe runs in unheated areas such as lofts, basements and garages should be treated as external runs.

Key to condensate illustrations, figures 7, 8 & 9	
1	Condensate discharge from appliance
2	Soil and vent stack
3	Minimum 450mm and up to three storeys
4	Visible air break at plug hole
5	Sink or basin with integrated overflow
6	75mm sink waste trap
7	Condensate pump
*	Condensate trap of 206mm already incorporated into the appliance

Table 11 Key to Internal condensate disposal methods

3.4.3 Internal connections

In order to minimise risk of freezing during prolonged cold spells, the following methods of installing condensate drainage pipe should be adopted, in order of priority.

Wherever possible, the condensate drainage pipe should be routed and terminated so that the condensate drains away from the appliance under gravity to a suitable internal foul water discharge point such as an internal soil and vent stack. A suitable permanent connection to the foul waste pipe should be used.

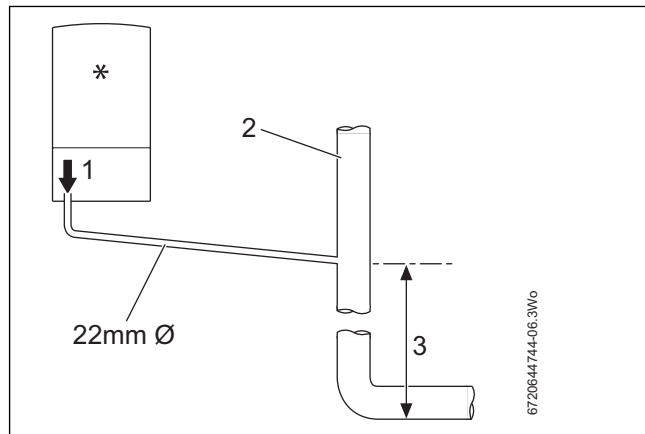

Fig. 7 Disposal to soil vent stack

Alternatively if the first option is not possible an internal kitchen or bathroom waste pipe, washing machine waste pipe etc. can be used. Ensure that the condensate drain pipe is connected “down stream” of the waste trap.

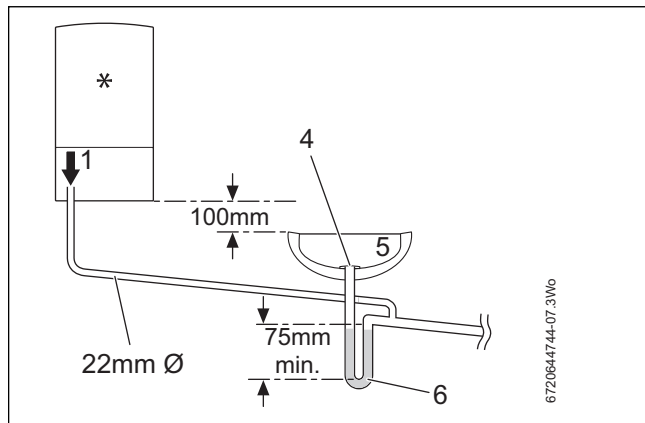

Fig. 8 Disposal to a waste pipe

Condensate pump

Where “gravity discharge” to an internal termination is not physically possible, or where very long internal runs would be required to reach a suitable discharge point, condensate should be removed using a proprietary condensate pump, of a specification recommended by the appliance or condensate pump manufacturer.

The pump outlet pipe should discharge to a suitable internal foul water discharge point such as an internal soil and vent stack, internal kitchen or bathroom waste pipe, washing machine waste pipe etc. A suitable permanent connection to the foul waste pipe should be used.

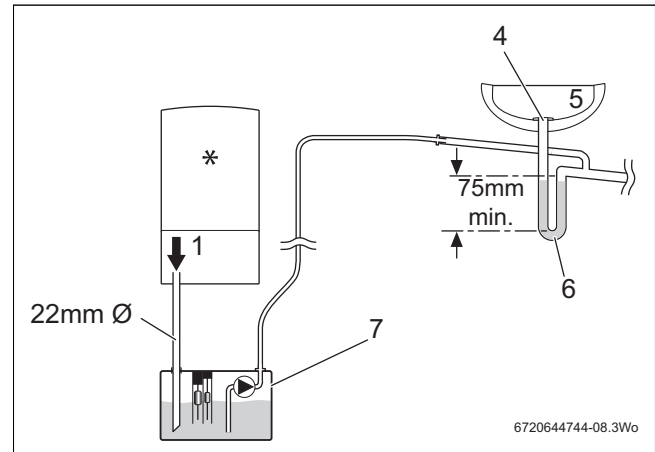

Fig. 9 Condensate pump disposal

3.4.4 External connections

NOTICE: Condensate waste

▶ Care should be taken when siting a soak-away to avoid obstructing existing services.

Continued - Key to condensate illustrations, figures 10, 11, 12 & 13

8	PVCu strap on fitting
9	100mm Ø minimum plastic pipe
10	Drainage holes
11	Limestone chippings
12	Bottom of sealed tube
13	Insulate and increase pipe size
14	Pipe work transition
15	External air break
16	Air gap
17	External rain water pipe into foul water
18	43mm 90° male/female bend
*	Condensate trap of 75mm already incorporated into the appliance

Table 12 Key to external condensate disposal methods

i Condensate drainage pipe can be run above or below ground.

If no other discharge method is possible then the use of an externally run condensate drainage pipe terminating at a suitable foul water discharge point, or purpose-designed soak away, may be considered. If this method is chosen then the following measures should be adopted:

- ▶ The external run be kept as short as possible and not exceed 3 metres.

- ▶ The pipe should be run internally as far as possible before going externally and the pipe diameter should be increased to 32mm before it passes through the wall to the exterior.
- ▶ The external pipe should take the shortest and least exposed route to the discharge point, and should "fall" as steeply as possible away from the appliance, with no horizontal runs in which condensate might stand.
- ▶ The use of fittings, elbows etc. should be kept to a minimum and any internal "burrs" on cut pipe work should be removed so that the internal pipe section is as smooth as possible.

Fitting an external air break

- Refer to figure 10 when a rain water down pipe is used to dispose of condensate.
- An air break must be installed in the 43mm pipe work, between the appliance condensate outlet and the drainpipe, outside the property, to avoid flooding during adverse weather conditions.

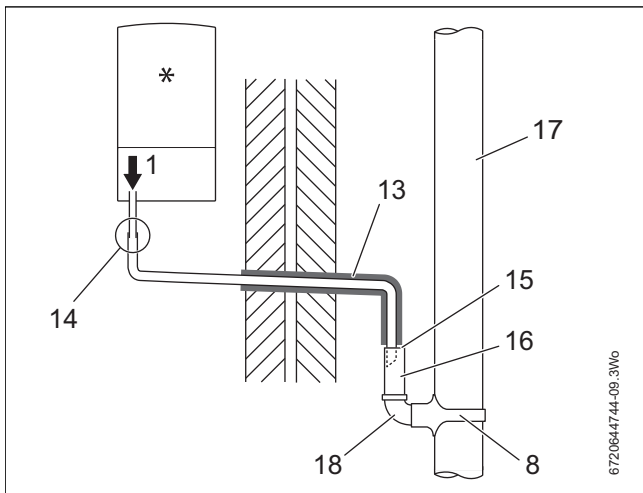

Fig. 10 Disposal into a rainwater down pipe

Where the pipe terminates over an open drain or gully, the pipe should terminate below the grating level, but above water level, in order to minimise "wind chill" at the open end.

The use of a drain cover (such as those used to prevent blockage by leaves) may offer further protection from wind chill.

Pipe drainage will be improved if the end is cut at 45° as opposed to a straight cut.

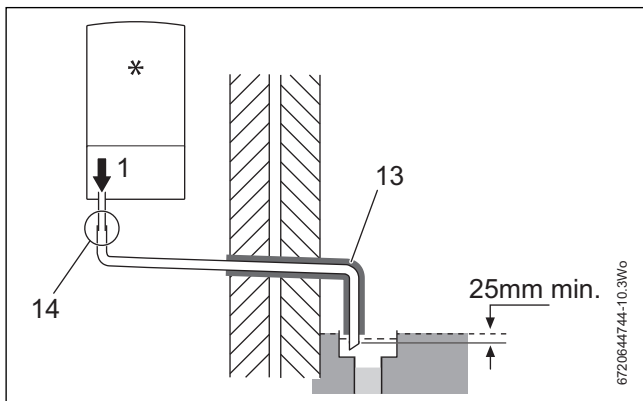

Fig. 11 External disposal

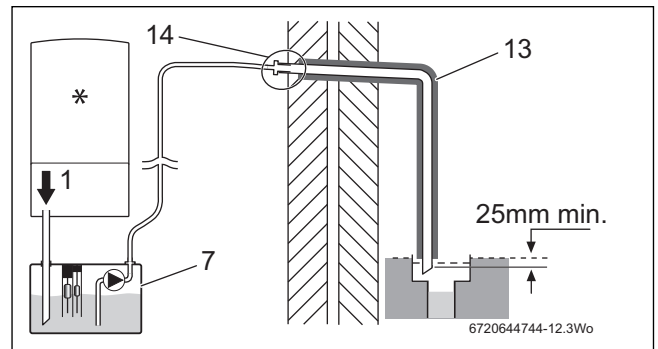

Fig. 12 Condensate pump to external disposal

Condensate soak away

- The condensate drainage pipe may be run above or below the ground to the soak away. The examples shown on this page run above ground.
- The soak away must use a 100mm Ø plastic tube with two rows of three 12mm holes on 25mm centres and 50mm from the bottom of the tube. The holes must face away from the house.
- The tube must be filled with and surrounded by at least 100mm of limestone chippings to a depth of 400mm.



Minimum hole size for the condensate soak away must be 400mm deep by 300mmØ.

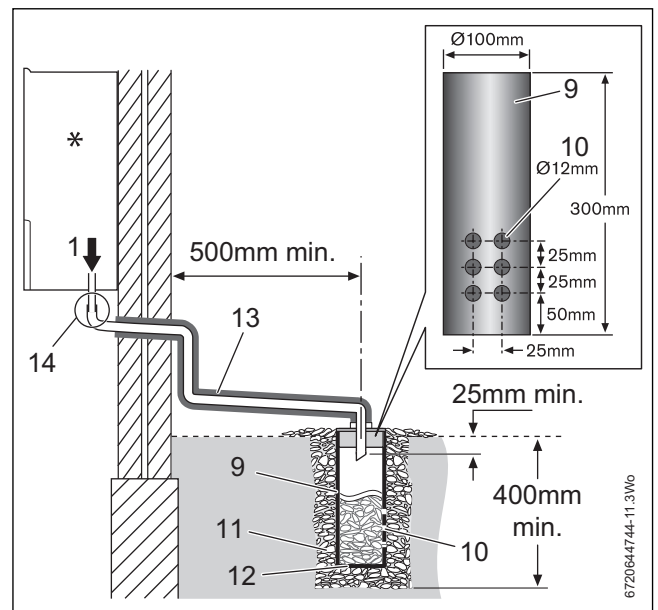

Fig. 13 Soak away

3.5 Boiler internal drain

The CDI Classic^{ErP} has the facility to drain the water direct from the boiler through the condensate pipe.

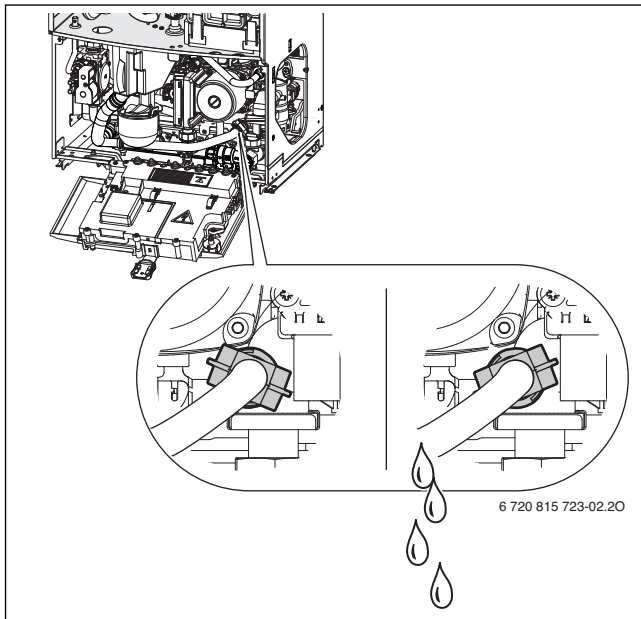

Fig. 14 Drain tap positions

If the boiler uses a soakaway or a condensate pump:

- ▶ Use an external drain point on the system to prevent excess system water being drawn through the soakaway or condensate pump

3.6 Pressure relief pipe work



NOTICE:

- ▶ The pressure relief valve is a safety device for the boiler and if activated may discharge boiling water or steam through the relief valve drain pipe.
- ▶ Care should be taken when siting the outlet pipe so that it does not cause an obstruction or discharge above a window, entrance or other public access where it could cause a hazard.

- The pressure relief drain pipe (1) from the boiler should be at least 15mm diameter copper pipe and run downwards, away from any electrical equipment or other hazard, preferably to an external drain or soak away.
- Pipe (1) should be finished with a partial bend, near the outlet to face the external wall (as shown) to help prevent freezing.

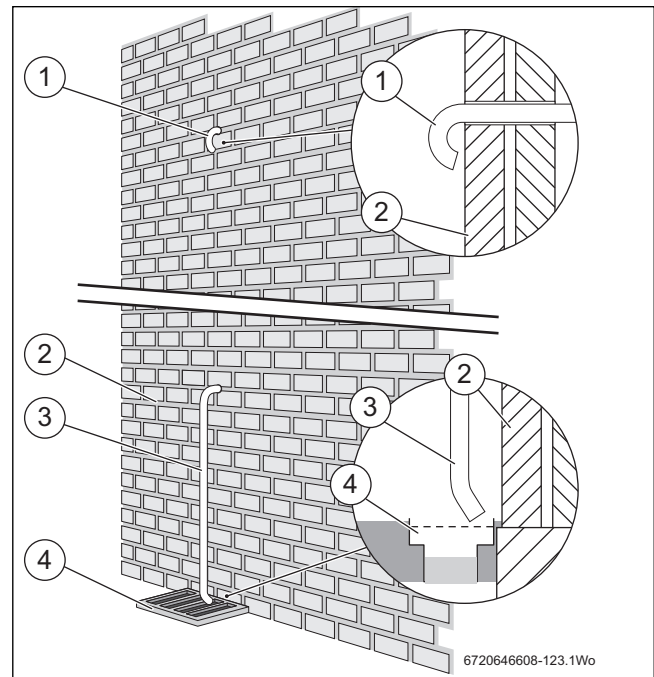

Fig. 15 Pressure relief pipe work

2	Outside wall
1,3	Drain pipe
4	External drain

Table 13 Key to fig 7

Remote Pressure Relief Valve Kit

For installations in a cellar or basement, there is an accessory that is available from Worcester that allows the pressure relief valve to be fitted remotely from the boiler. This accessory can be used when there is difficulty accessing an external drain.

The part number for this kit is: 7 716 161 071

3.7 Boiler location & clearances

This boiler is only suitable for installing internally within a property at a suitable location onto a fixed, rigid surface at least the same size as the boiler and capable of supporting the boiler weight.



NOTICE:

No surface protection is required against heat transfer from the boiler.

COMPARTMENTS:

Follow the requirements of BS6798 and BS5440 Part 2 and note:

- Minimum clearances must be maintained
- An access door is required to install, service and maintain the boiler and any ancillary equipment.
- If an airing cupboard is adapted to house a boiler, then the airing spaces must be separated from the boiler compartment by a noncombustible partition. The partition may be perforated, if required, by holes not exceeding 13 mm in diameter.
- If the appliance is fitted into a cupboard or a compartment is built around the appliance after installation, then the compartment must be built or lined by a non-combustible material.

BOILER CLEARANCES:

The drawing below Fig. 16 shows the minimum space required to install and service the boiler.

VENTILATION

This is a room sealed appliance and does not require any air for combustion from inside the property.

The requirements of BS 6798 and BS 5440 regarding ventilation do not apply, with the Greenstar CDi System^{ErP} boiler. There is no need for ventilation openings to be provided in the compartment because of the low heat loss from the appliance casing, if the clearances shown are maintained.

Do not operate the appliance if the flue terminal fitted on the outside wall or roof is obstructed or damaged.

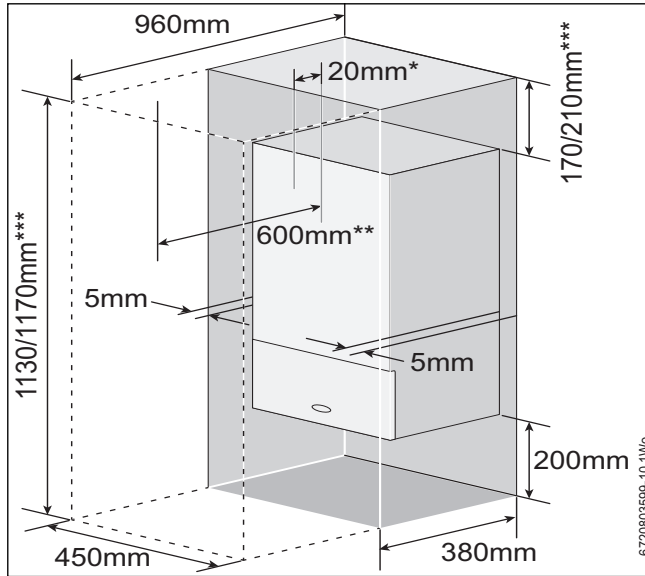

Fig. 16 Minimum clearances

*	Minimum clearance to removable door
**	Minimum clearance required for servicing
***	Height for either 60/100 or 80/125 flue

Table 14 Minimum clearances

Compartments

Follow the requirements of BS6798 and BS5440 Part 2 and note:

- Minimum clearances must be maintained.
- An access door is required to install, service and maintain the boiler and any ancillary equipment.
- If fitting the boiler into an airing cupboard use a non-combustible material to separate the boiler from the airing space.
- The material can be perforated up to a maximum hole size of 13mm.

BATHROOMS:

A boiler fitted without an optional timer or with no timer can be installed in zone 2 or outside the shaded area .

Additional RCD (Residual Current Device) protection may be required. Refer to the latest IET wiring regulations.

NOTICE: Any switch or appliance control using 230 V mains electricity must not be able to be touched by a person using the bath or shower. Electrical switches, fused spur and socket outlets must not be situated in the bathroom.

For further information about bathroom installations please consult Operational Procedures Part 20, Electricity.

BATHROOM INSTALLATIONS

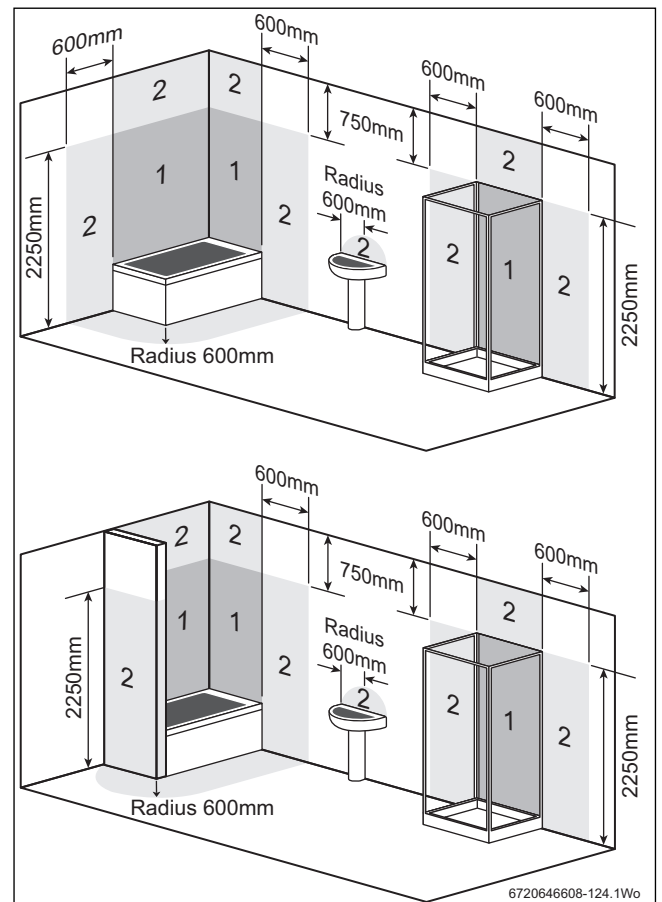

Fig. 17 Bathroom installations

3.8 Plumbing manifold

NOTICE:

- ▶ **IF FITTING OPTIONAL INTEGRAL DIVERTER VALVE** install the pipe work as shown in figure 18 (also see additional information in the document supplied with the diverter valve kit).
- ▶ **If no diverter valve is fitted** install the pipe work as shown in figure 19.

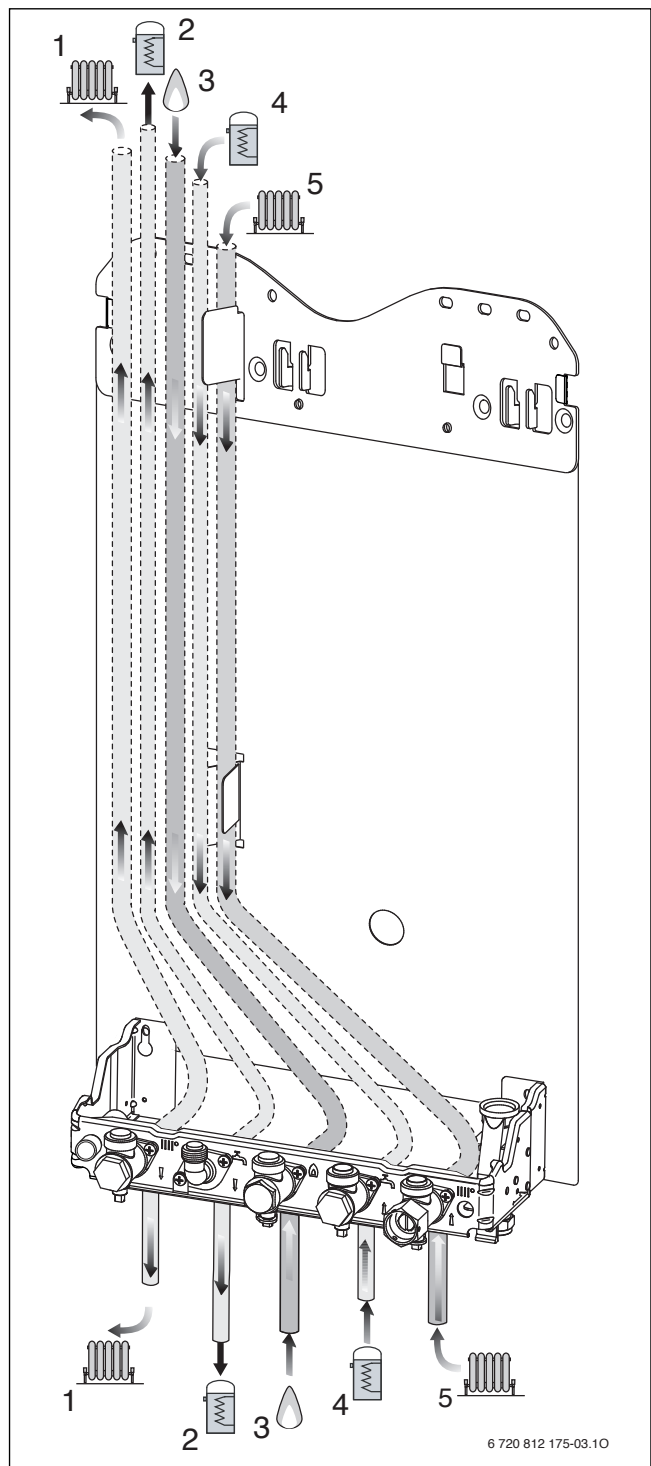

Fig. 18 With optional integral diverter valve

- [1] Central heating flow 22mm
- [2] Cylinder flow 15mm
- [3] Mains gas supply 22mm
- [4] Cylinder return 15mm
- [5] Central heating return 22mm

CONNECTIONS:

Heating system: 22 mm compression fittings

DHW: 15 mm compression fittings

Gas: 22 mm compression fittings

Use the fittings supplied in the Hardware pack.

PREPLUMBING

With the plumbing manifold installed, pipe work can be installed to the valves on the manifold.

The valves can be closed enabling CH system to be tested. The boiler can be installed at later date.

RUNNING PIPES BEHIND THE BOILER

If the boiler pipes are to be run behind the appliance ensure that the pipes pass close to the wall as shown in the diagram opposite, and within the pipe guide.

Alternatively an optional pre-bent pipe kit can be purchased, part number 7 716 192 651.

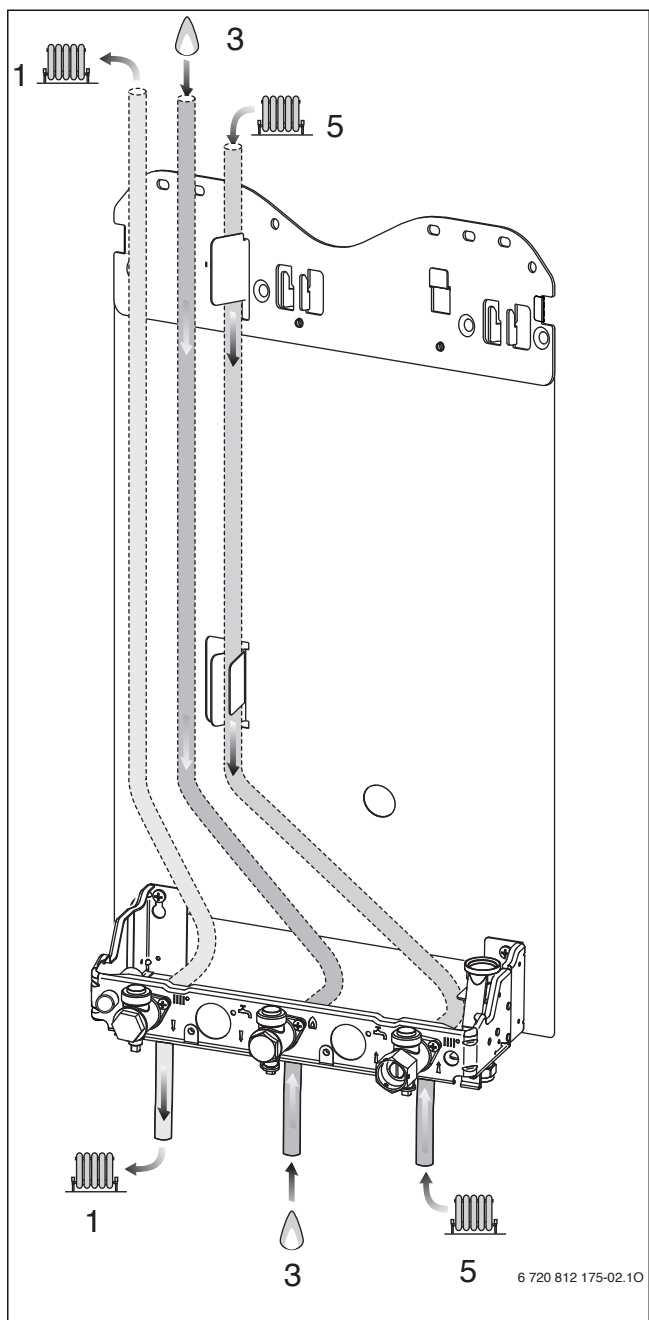

Fig. 19 Without optional diverter valve

3.9 Flue options

The Greenstar CDi Classic System ^{ErP} has the option of three horizontal RSF (60/100 telescopic, 60/100 longer telescopic and 80/125 telescopic) flue systems and two vertical RSF (60/100 or 80/125) regular flue systems:

The systems have different maximum flue lengths for different boiler outputs and different plume management lengths.

For every extra 1000mm of plume management after the first 500mm, the internal 60/100 flue length must be reduced by 700mm, up to a maximum of 4500mm of plume management.

For example on a 30CDi Classic System ^{ErP} if the plume management effective length was 1500mm, the inner flue would be reduced to 5200mm.

Maximum horizontal flue lengths (L)				
Boiler model	100mmØ			125mmØ
	No Plume management	+ 500mm of plume management	+4500mm of plume management	No plume management available
30CDi	7,900mm	5,900mm	3,100mm	18,500mm
35CDi	7,000mm	5,000mm	2,200mm	16,000mm

Table 15 Maximum horizontal flue lengths

Maximum vertical flue lengths		
Boiler model	100mmØ	125mmØ
30CDi	9,400mm	18,500mm
35CDi	8,000mm	16,000mm

Table 16 Maximum vertical flue lengths

This page and the page opposite shows various flue options with the straight flue lengths required to achieve the maximum flue length.



NOTICE: 60/100 Flue systems:

- ▶ Each 90° bend used is equivalent to 1.5 metres of straight flue.
- ▶ Each 45° bend used is equivalent to 0.75 metres of straight flue.



NOTICE: 80/125 flue systems:

- ▶ Each 90° bend used is equivalent to 2 metres of straight flue.
- ▶ Each 45° bend used is equivalent to 1 metre of straight flue.

Telescopic horizontal flue		
Flue option 1	100mmØ	125mmØ
30CDi	570mm	600mm
35CDi	570mm	600mm

Table 17 Option 1

Horizontal extended flue		
Flue option 2	100mmØ	125mmØ
30CDi	7,900mm	18,500mm
35CDi	7,000mm	16,000mm

Table 18 Option 2

Horizontal extended flue with 1x90° bends		
Flue option 3	100mmØ	125mmØ
30CDi	6,400mm	16,500mm
35CDi	5,500mm	14,000mm

Table 19 Option 3

Horizontal extended flue with 2x90° bends		
Flue option 4	100mmØ	125mmØ
30CDi	4,900mm	14,500mm
35CDi	4,000mm	12,000mm

Table 20 Option 4

High level horizontal extended flue		
Flue option 5	100mmØ	125mmØ
30CDi	7,900mm	18,500mm
35CDi	7,000mm	16,000mm

Table 21 Option 5

High level horiz. extended flue with 2x90° bends		
Flue option 6	100mmØ	125mmØ
30CDi	6,400mm	16,500mm
35CDi	5,500mm	14,000mm

Table 22 Option 6

High level horiz. extended flue with 3x90° bends		
Flue option 7	100mmØ	125mmØ
30CDi	4,900mm	14,500mm
35CDi	4,000mm	12,000mm

Table 23 Option 7

Vertical balanced extended flue assembly		
Flue option 8	100mmØ	125mmØ
30CDi	9,400mm	18,500mm
35CDi	8,000mm	16,000mm

Table 24 Option 8

Vertical balanced extended flue with 2x90° bends		
Flue option 9	100mmØ	125mmØ
30CDi	6,400mm	14,500mm
35CDi	5,000mm	12,000mm

Table 25 Option 9

Vertical balanced extended flue with 2x45° bends		
Flue option 10	100mmØ	125mmØ
30CDi	7,900mm	16,500mm
35CDi	6,500mm	14,000mm

Table 26 Option 10

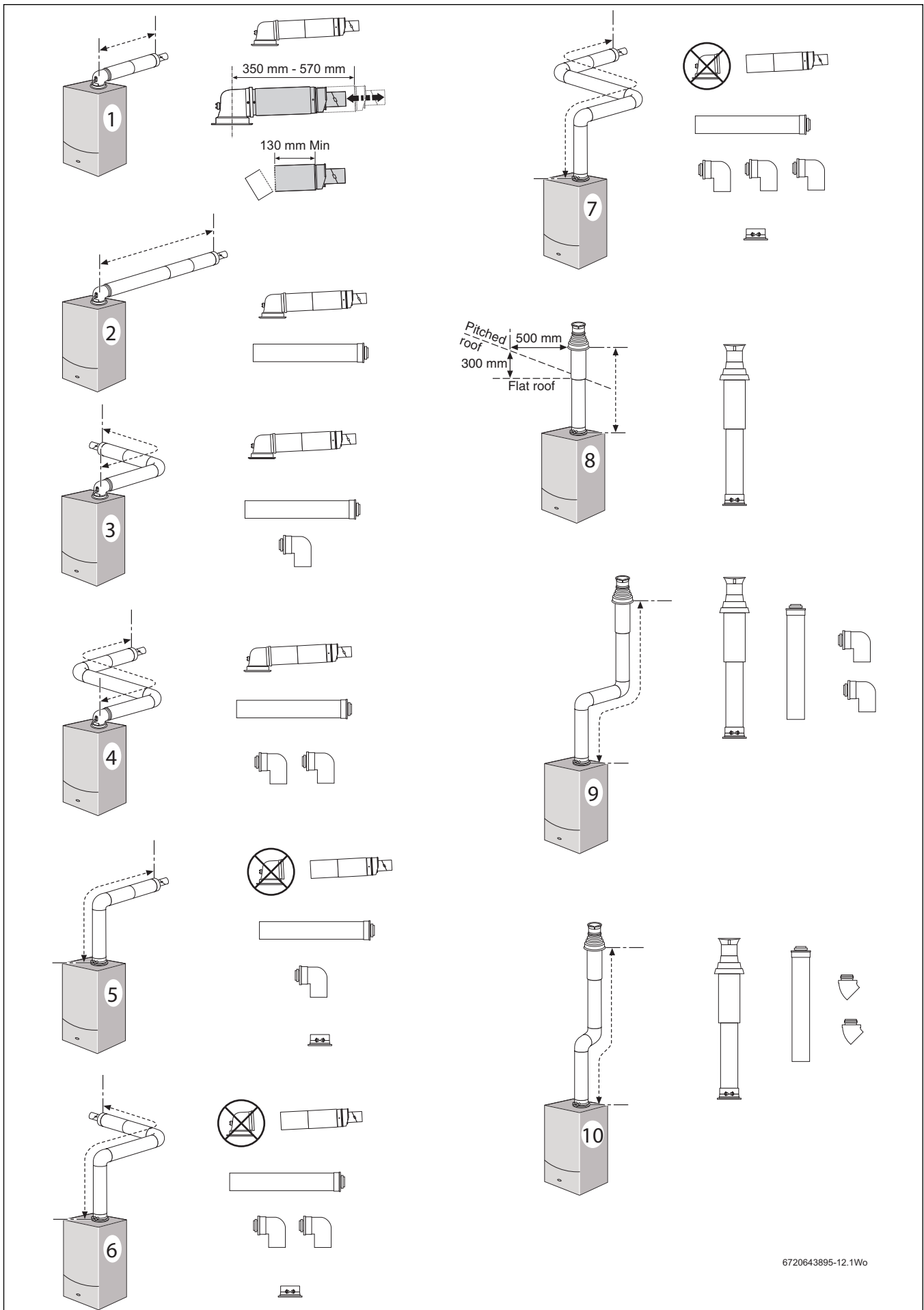

Fig. 20

3.10 Flue terminal positions

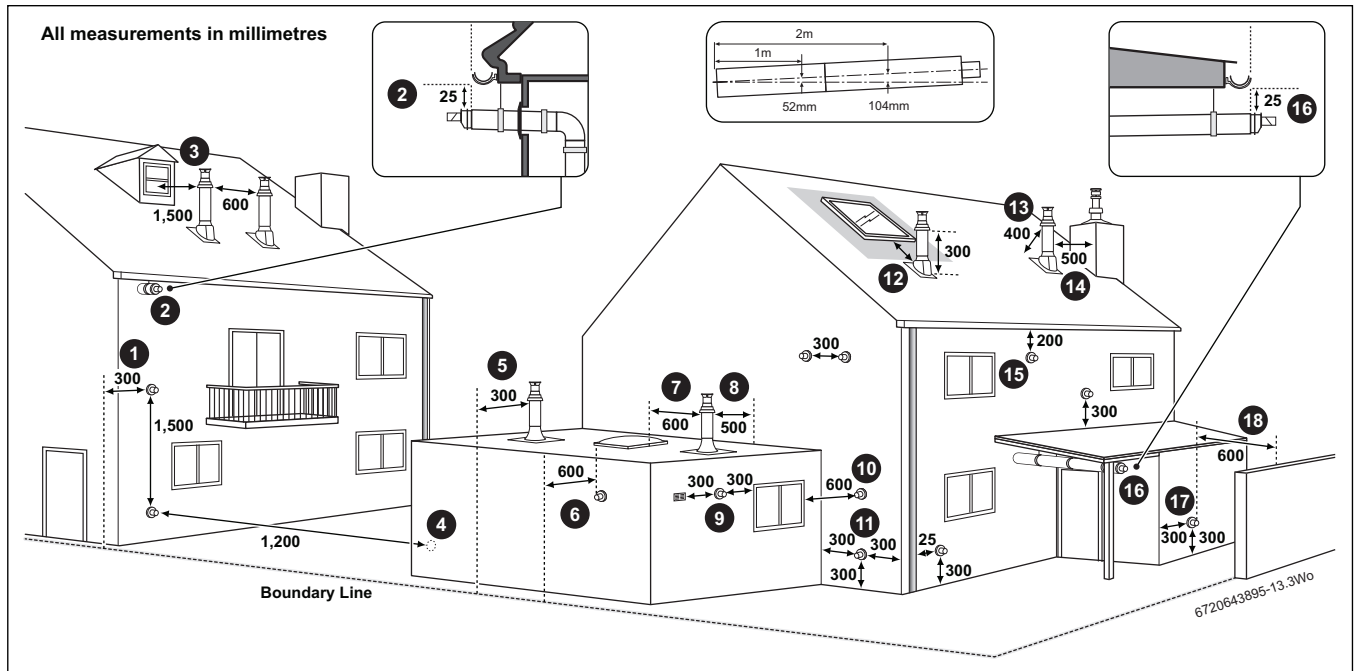

Fig. 21 Flue terminal positions

NOTICE:

- ▶ All measurements are the minimum clearances required.
- ▶ Terminals must be positioned so to avoid combustion products entering the building.
- ▶ Support the flue at approximately one metre intervals and at a change of direction, use suitable brackets and fittings (100mm flue bracket part number: 7 716 191 177, flue brackets 100mm x 6 part number: 7 716 191 178, 125mm flue bracket part number: 7 716 191 179).

Key to illustration

1. 300mm adjacent to a boundary line.
2. The dimension below eaves, balconies and car ports can be reduced to 25mm, as long as the flue terminal is extended to clear any overhang. External flue joints must be sealed with suitable silicon sealant.
3. 1,500mm between a vertical flue terminal and a window or dormer window.
4. 1,200mm between terminals facing each other.
5. Vertical flue clearance, 300mm adjacent to a boundary line.
6. 600mm distance to a boundary line, unless it will cause a nuisance. BS 5440:Part 1 recommends that care is taken when siting terminal in relation to boundary lines.
7. 600mm minimum clearance from a skylight to a vertical flue.
8. Vertical flue clearance, 500mm to non-combustible building material, and 1,500mm clearance to combustible building material.
9. 300mm above, below and either side of an opening door, air vent or opening window.
10. 600mm diagonally to an opening door, air vent or opening window.
11. 300mm to an internal or external corner.
12. 2,000mm below a Velux window, 600mm above or to either side of the Velux window.
13. 400mm from a pitched roof or 500mm in regions with heavy snow fall.
14. 500mm clearance to any vertical structure on a roof, 600mm to room sealed flue or 1,500 to an open flue.
15. 200mm below eaves and 75mm below gutters, pipe and drains.

16. The dimension below eaves, balconies and car ports can be reduced to 25mm, as long as the flue terminal is extended to clear any overhang. External flue joints must be sealed with suitable silicon sealant.
17. Flue clearance must be at least 300mm from the ground. Terminal guards must be fitted if the flue is less than 2 metres from the ground or if a person could come into contact with the flue terminal.
18. 600mm distance to a surface facing a terminal, unless it will cause a nuisance. BS 5440: Part 1 recommends that care is taken when siting terminals in relation to surfaces facing a terminal.



Note:

- ▶ Installations in car ports are not recommended.
- ▶ The flue cannot be lower than 1,000mm from the top of a light well due to the build up of combustion products.
- ▶ Dimensions from a flue terminal to a fanned air inlet to be determined by the ventilation equipment manufacturer.

3.11 Plume management terminal positions

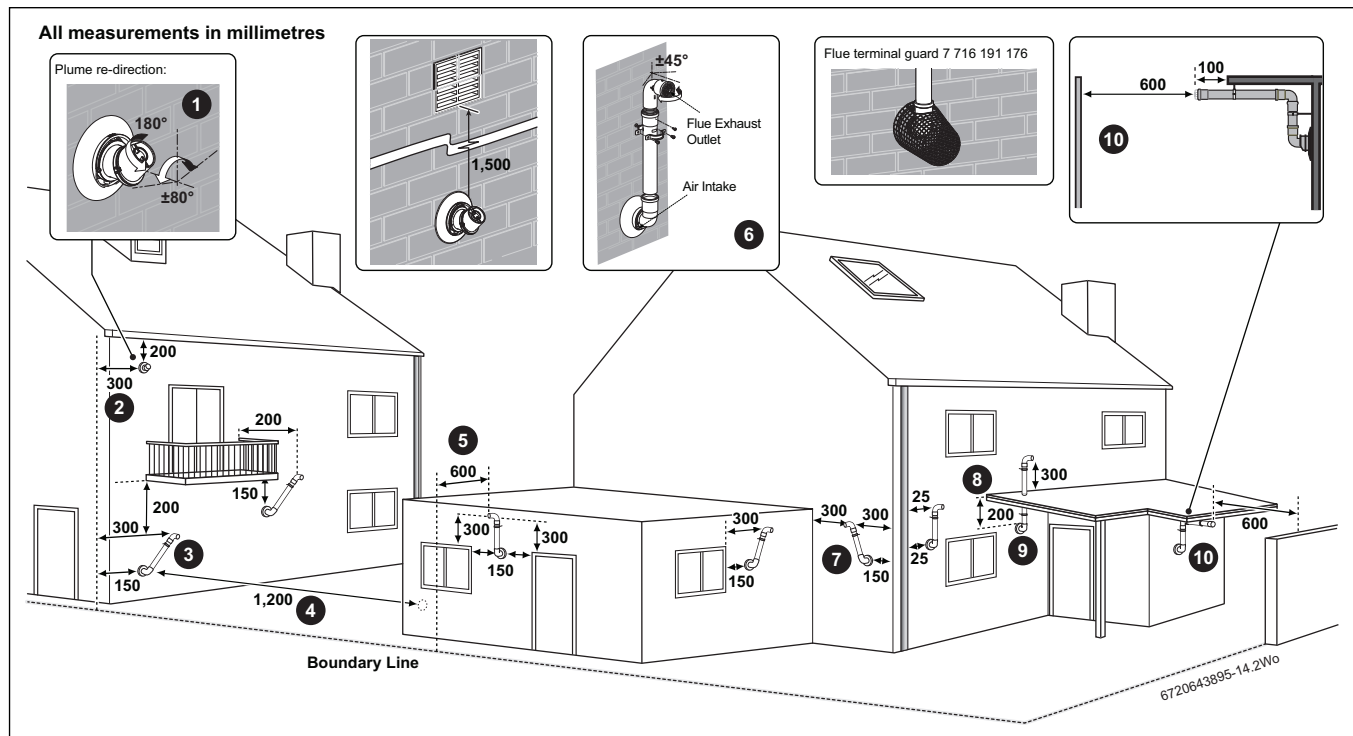

Fig. 22 Plume terminal positions

NOTICE:

- ▶ All measurements are the minimum clearances required.
- ▶ The minimum length plume management length is 500mm to a maximum of 4500mm, this includes two 90° bends. Refer to section 3.9 and table 15 for further information on internal flue lengths.
- ▶ Subsequent 45° bends = 750mm and 90° = 1500mm.
- ▶ For each metre (1000mm) of plume management length the internal flue length is reduced by 700mm.
- ▶ Refer to previous page for all concentric flue terminal positions unless the flue position is specified on the figure above “Plume terminal positions”.
- ▶ Terminals must be positioned so to avoid combustion products entering the building.
- ▶ Support the flue at approximately one metre intervals and at a change of direction, use suitable brackets and fittings.

Key to illustration

1. This feature allows some basic plume re-direction options on a standard telescopic horizontal flue terminal. 300mm minimum clearances to an opening e.g. window. However the minimum clearances to an opening in the direction that the plume management is facing, must be increased to 1,500mm. Where the flue is less than 150mm to a drainpipe and plume re-direction is used the deflector should not be directed towards the drainpipe.
2. 300mm adjacent to a boundary line.
3. Plume Management kit air intake can be reduced to 150mm providing the flue exhaust outlet is no less than 300mm adjacent to a boundary line.
4. 1,200mm between terminals facing each other.
5. 600mm distance to a boundary line, unless it will cause a nuisance. BS 5440: Part 1 recommends that care is taken when siting terminal in relation to boundary lines.
6. Using a Plume Management kit the air intake measurement can be reduced to 150mm providing the flue exhaust outlet has a 300mm clearance. Plume kits running horizontally must have a 10° fall back to the boiler for proper disposal of condensate. For details on specific lengths see relevant boiler Technical & Specification information.

7. Internal/external corners. The air intake clearance can be reduced to 150mm providing the flue exhaust outlet has a 300mm clearance.
8. Clearances no less than 200mm from the lowest point of the balcony or overhang.
9. 1,200mm from an opening in a car port on the same wall e.g. door or window leading into the dwelling.
10. 600mm distance to a surface facing a terminal, unless it will cause a nuisance. BS 5440: Part 1 recommends that care is taken when siting terminals in relation to surfaces facing a terminal.



Note:

- ▶ Installations in car ports are not recommended.
- ▶ The flue cannot be lower than 1,000mm from the top of a light well due to the build up of combustion products.
- ▶ Dimensions from a flue terminal to a fanned air inlet to be determined by the ventilation equipment manufacturer.

4 INSTALLATION



NOTICE: All the previous Pre-Installation sections must be read and requirements met before starting boiler or flue installation.

4.1 Unpacking wall frame and ancillary items

LIFTING AND CARRYING PRECAUTIONS:



WARNING:

- ▶ Lift only a manageable weight, or ask for help.
- ▶ When lifting the boiler, bend the knees, and keep the back straight and feet apart.
- ▶ Do not lift and twist at the same time.
- ▶ Lift and carry the boiler close to the body.
- ▶ Wear protective clothing and gloves to protect from any sharp edges.

IMPORTANT HANDLING INSTRUCTIONS

- It is advised that two people are used to carry the carton from the van to the point of delivery.
 - Once the carton has been delivered, the top of the carton is opened. If a sharp implement is used make sure the carton is not pierced and that the implement is used in such a way so that it may not cause personal injury. All sharp objects must be covered or the blade retracted after use and put away in a safe place.
1. The upper support is now removed with the components (bottom panel, pre-plumbing manifold, fixings, documentation set, charging link, hanging bracket).
 2. The boiler wall mounting plate can now be pulled out.

Additional requirements for roof space installation:

- The boiler should be first unpacked before ascending ladder to loft space.
- Two sets of steps should be used.
- Two people should share the lifting of the boiler up to the loft hatch, where the boiler is entered into the loft space tilted and slid on its back into the loft.

Once the appliance is removed from its packaging check the contents against the packing list.



NOTICE: Before installing appliance ensure system has been cleaned as explained on page 10.

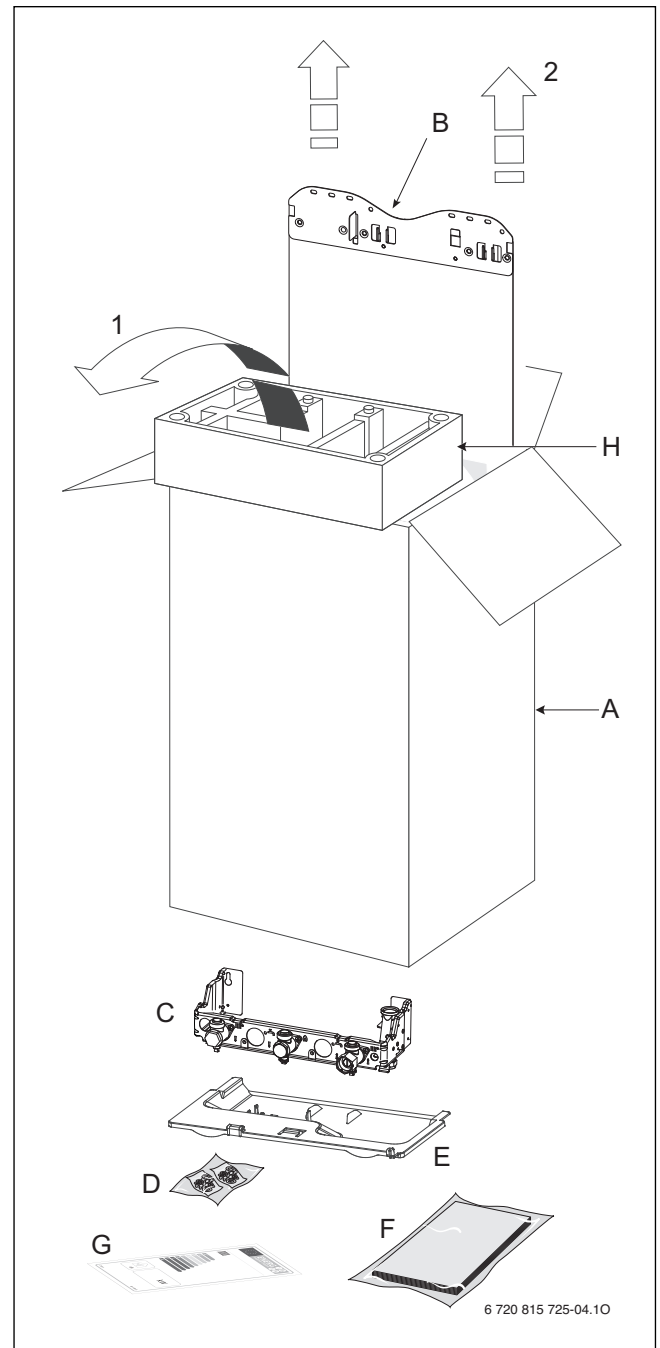
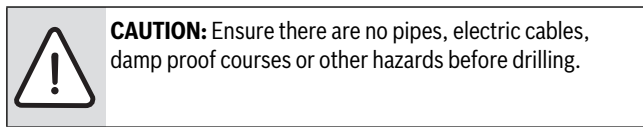

Fig. 23

- A - Carton
- B - Wall mounting plate with hanging bracket
- C - Pre-plumbing manifold
- D - Hardware pack
- E - Bottom panel
- F - Literature pack
- G - ErP energy label
- H - Upper support (polystyrene)

4.2 Wall mounting plate and flue opening



SAFETY:

All relevant safety precautions must be undertaken. Protective clothing, foot wear, gloves and safety goggles must be worn as appropriate.

FIXING THE POSITION OF THE WALL MOUNTING PLATE:

- Fig. 24 shows the relative positions of the flue and the fixing of the wall mounting plate, the hanging bracket and pre-plumbing manifold.

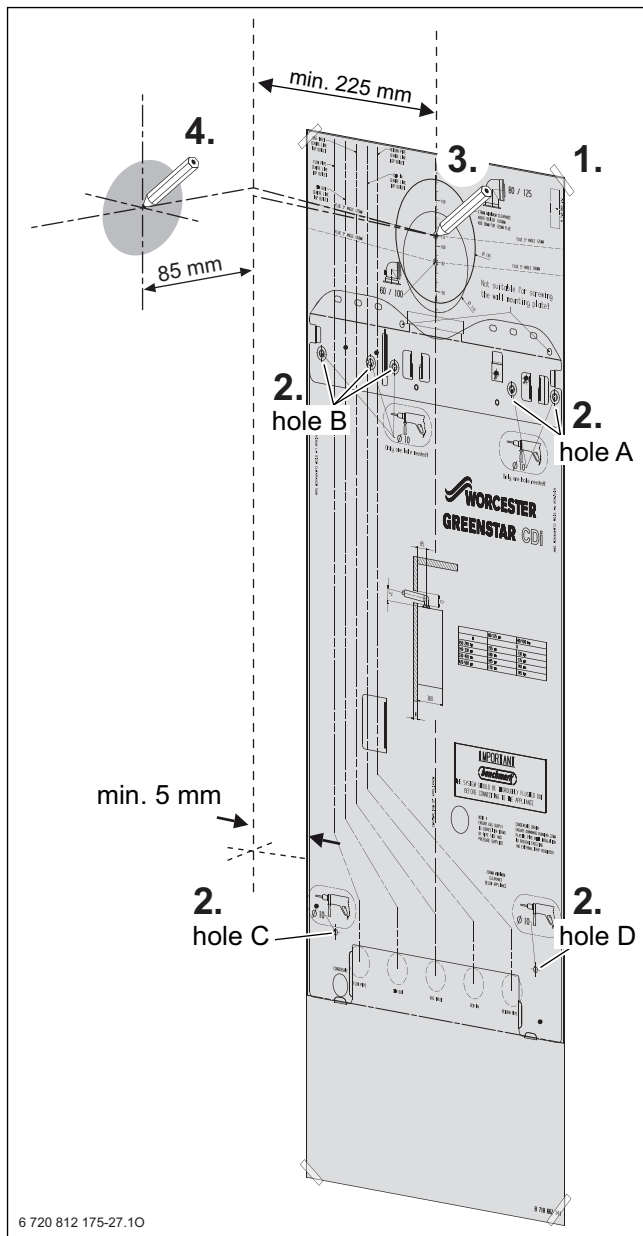

Fig. 24 Mounting template

- ▶ Fix the wall mounting template, supplied with the literature pack, to the wall.
- ▶ Drill holes for wall mounting plate and pre-plumbing manifold:
 - at least one of the holes A,
 - at least one of the holes B (preferably use left hole),
 - hole C,
 - hole D.
- ▶ If required: make a hole in wall for the flue pipe.

FLUE OUTLET

- ▶ Follow the Fig. 24 to mark the centre of the flue for rear outlet (3) or for side outlet (4).
- ▶ For the 60/100mm Ø flue make a 125 mm diameter hole through the wall using a core drill or similar. For flues using an optional weather collar, fitted from inside the building make a 150 mm Ø hole.
- ▶ Clear away any debris.
- ▶ Drill the hole, preferably using a core drill.
- ▶ Remove the mounting template.
- ▶ Place the wall mounting plate with hanging bracket against the wall in the desired position.
- ▶ Secure wall mounting plate with four screws (supplied with the boiler). Do not fully fasten the lower two screws.
- ▶ Mount the pre-plumbing manifold on the two lower screws and secure the screws.

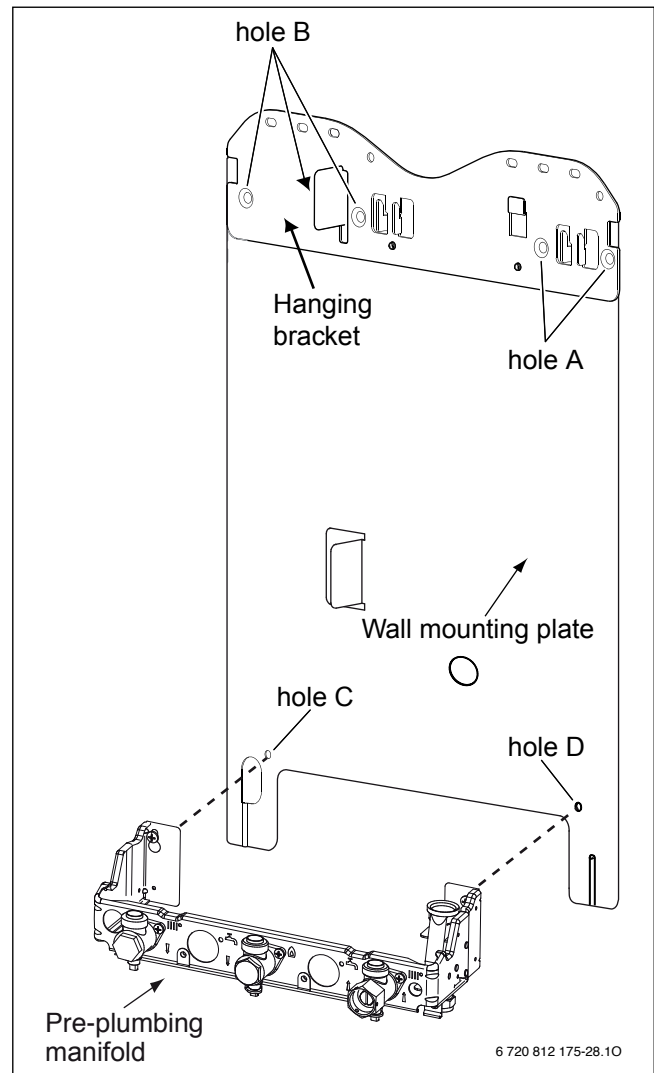

Fig. 25 Wall mounting plate and pre-plumbing manifold

4.3 Unpacking the appliance

1. With the wall frame and ancillary items removed lay the carton (A) on its back.
2. Open the carton bottom flaps and fold under boiler. Do not remove the packaging base.
3. Stand carton (A) with boiler upright on the packaging base (B).
4. Remove outer carton (A) and place safely away from the working area.
5. Remove the protective wrapping (C).
6. Lie the boiler on its back.
7. Remove the packaging base (B) and place safely away from the working area.

REMOVING OUTER CASE

8. Loosen but do not remove the 2 screws (E) securing boiler casing at the bottom of the appliance.
9. Pull upwards to release the clip (F) on top of the boiler and pull the case upwards.
10. Remove the outer case.
11. Remove the protective packaging (G) from the electrode assembly.

- A - Outer carton
- B - Packaging base
- C - Protective wrapping
- D - Appliance outer case
- E - Screws
- F - Clip
- G - Protective packaging

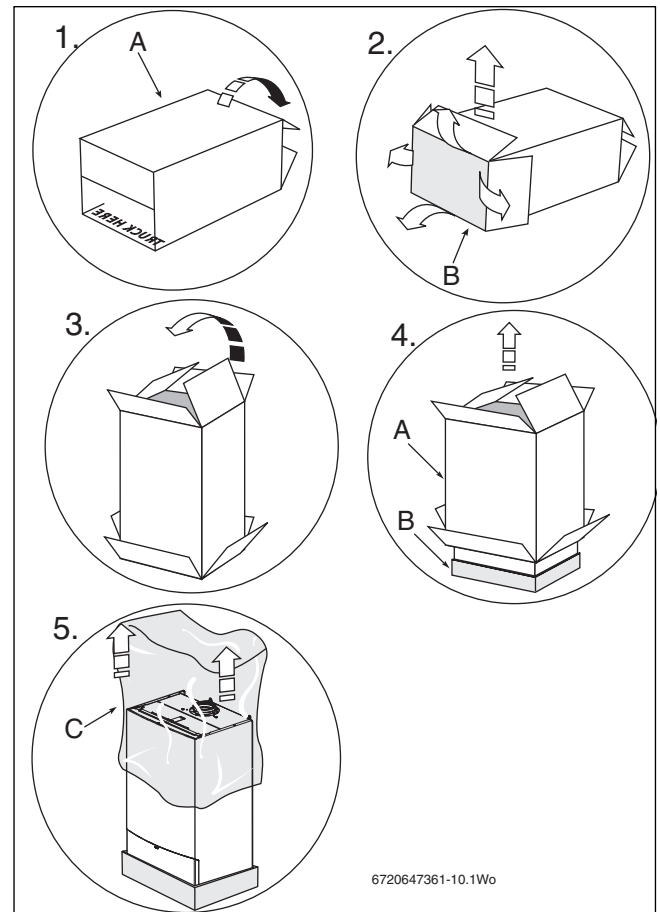

Fig. 26

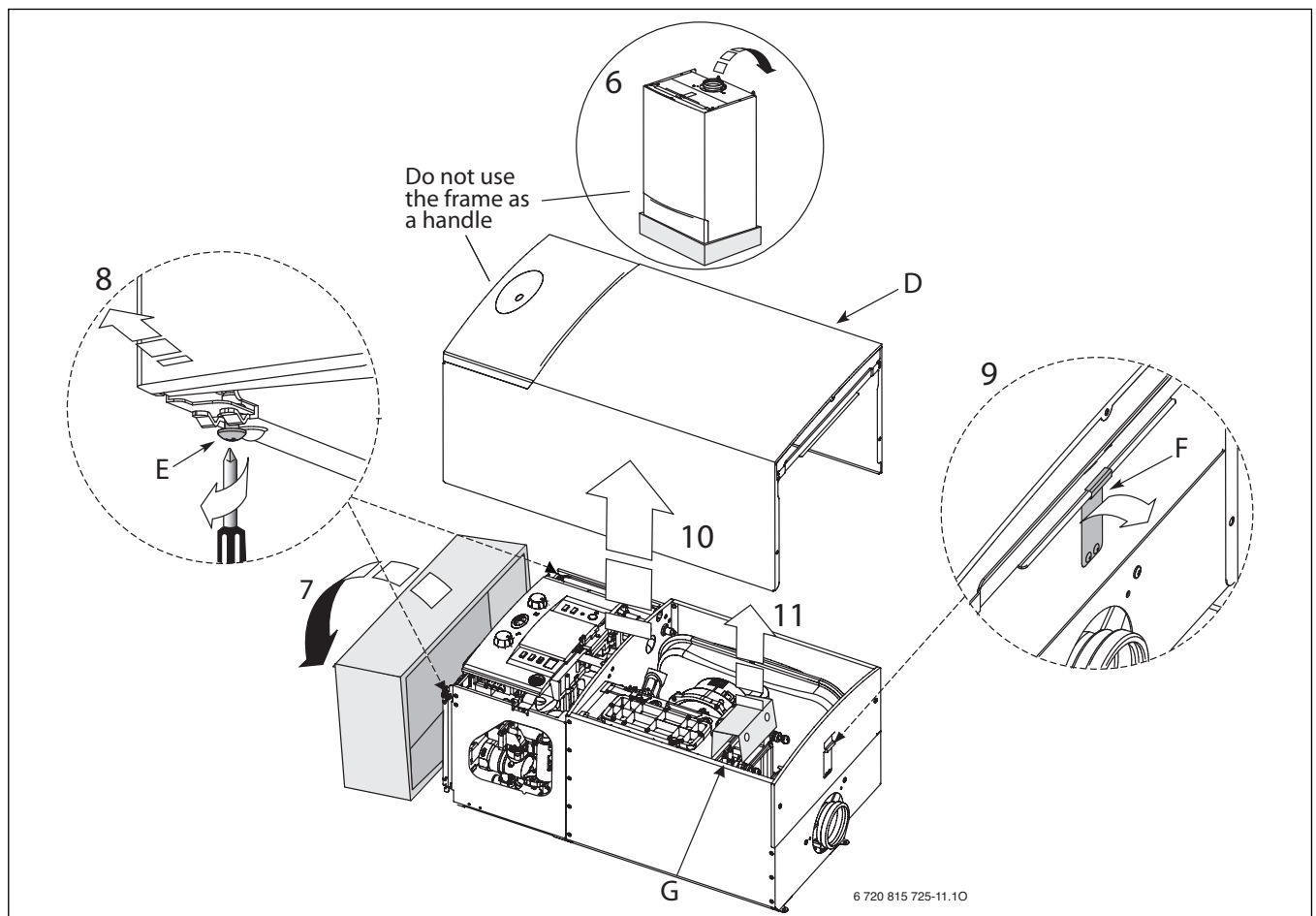

Fig. 27 Unpacking the boiler

4.4 Fitting the appliance/boiler connections

CAUTION: Isolate the mains gas supply before starting any work and observe all relevant safety precautions.

GAS AND WATER CONNECTIONS:

- ▶ System pipes may be run vertically upwards behind the boiler or below it. See Plumbing Manifold Section on page 16.

- A - CH flow (22 mm)
- B - CH return (22 mm)
- C - Gas inlet (22 mm)

If optional diverter valve is to be fitted:

- D - Cylinder flow (15 mm)
- E - Cylinder return (15 mm)

- ▶ Fit sealing washers to service valves before hanging boiler.
- ▶ Remove dust caps from connections on boiler.

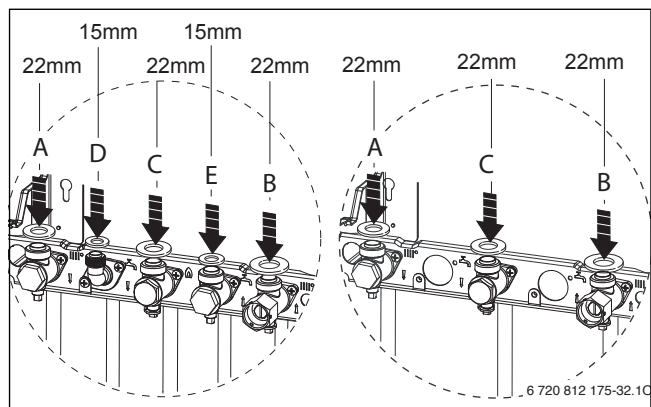

Fig. 28 Sealing washers

i The accessibility to the preplumbing manifold can be improved by removing the condensate trap (see also page 41).

NOTICE: Before hanging the boiler on the wall mounting plate ensure the pressure relief valve connection is in the DOWN position. This is located on the right hand side of the wall frame at the rear.

- ▶ The pressure relief connector must be repositioned after the boiler has been correctly mounted to the wall plate. Refer to action step 5.

1. Pull the extended tab/lever forward and down until there is no further travel.
2. Hang the boiler on to the hanging bracket. The lugs pass through the rectangular holes in the boiler back panel. Take care not to disturb the washers on the connections.

i It is recommended that this lifting operation is carried out by 2 people, observing all precautions for the safe lifting of heavy objects. Do not lift by the top case panel. There are two handling holes incorporated into the inner casing left and right in the lower section of the appliance.

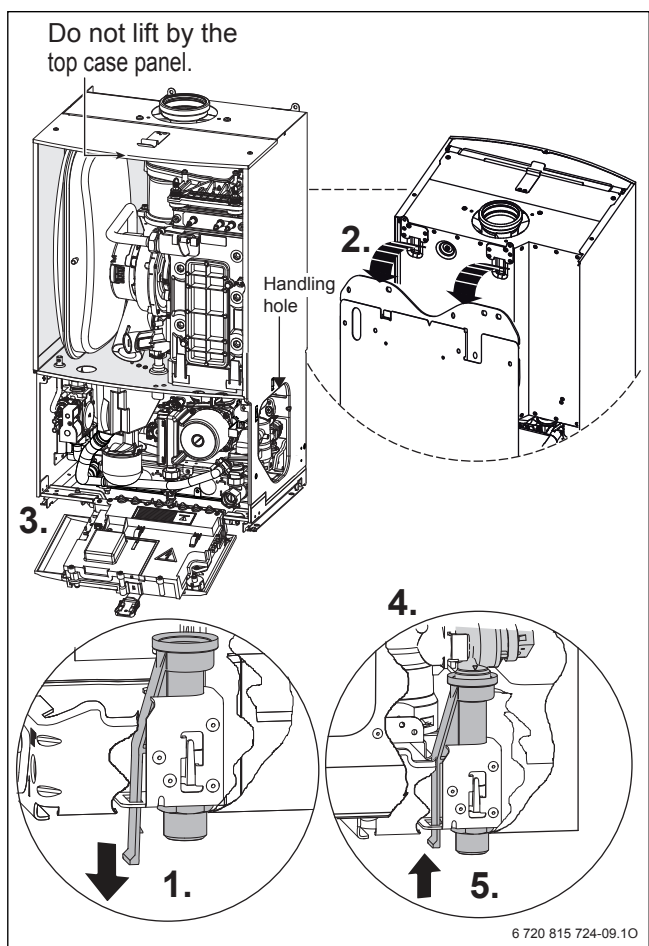

Fig. 29

3. Lower the control panel into the service position by squeezing the white plastic clip and then pulling the clip down.
4. Make connections to the heating system.
 - ▶ Connect the gas supply to the boiler gas cock 22mm compression.
 - ▶ If the optional diverter valve is to be fitted: Connect cylinder flow and return.

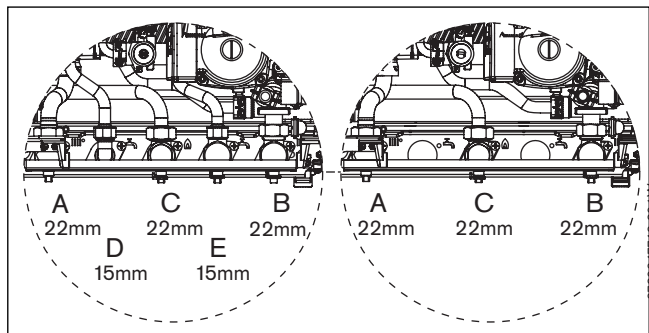

Fig. 30 Boiler connections

NOTICE: The pressure relief connector must be repositioned after the boiler has been correctly mounted to the wall mounting plate.

5. Push the lever on the pressure relief connector UP until the stop on the inside of the handle is over the shoulder of the metal bracket to secure in place.

4.5 Flue installation

HORIZONTAL FLUE (60/100 mm diameter)

For vertical flues and 80/125mm horizontal flues, please refer to separate Flue Kit instructions.



Apply silicone lubricant to the sealing surfaces of the flue components to ease assembly of flue components.

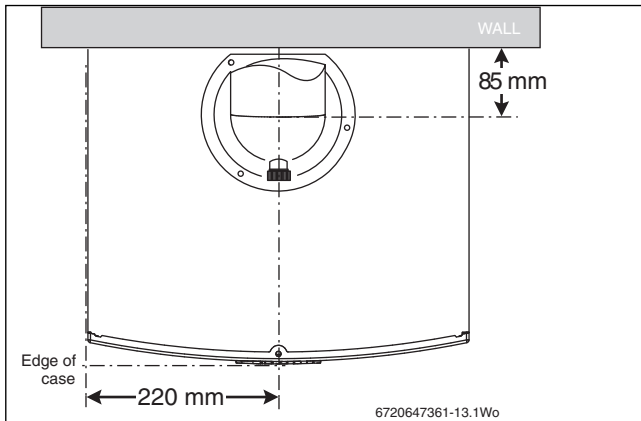

Fig. 31

4.5.1 Ø 60/100 mm Telescopic flue kit

Standard telescopic flue 350 - 570mm ,
part Number: 7 716 191 082

Longer Telescopic flue 570 - 790mm,
part number: 7 716 191 171

The standard telescopic flue terminal length can be reduced or extended to within 350 to 570 mm or 570 to 790mm for the longer telescopic flue without cutting and can be used with Condensit II flue extension components.

The terminal end of the standard telescopic flue can be further reduced to 130mm, if necessary, refer to the Flue Instruction manual supplied. The plume deflector can be adjusted to redirect the flue discharge allowing some plume management control, alternatively, a complete plume management system can be fitted to the flue terminal. Refer to the Flue Instruction manual supplied with the flue kit.

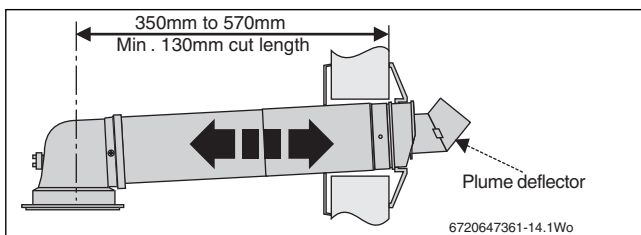

Fig. 32 Telescopic flue

4.5.2 Ø 60 mm Plume management kit

Part Number: 7-716-191-086

The plume management system connects to the terminal outlet of the Telescopic flue and must not be used with the flue terminal of the Standard Flue Kit.

The plume management system can be reduced by cutting (min. 500mm) and can be used with plume management extension components.

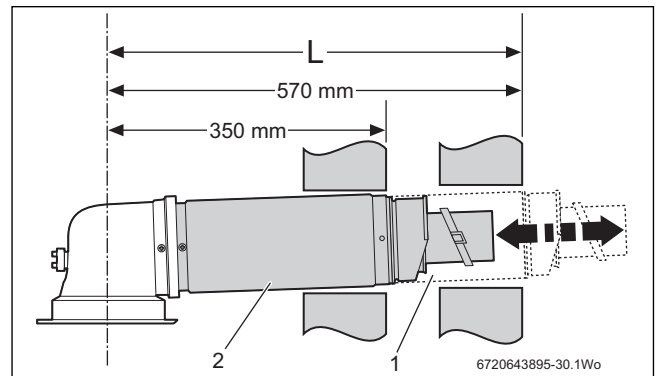

Fig. 33

Ø60mm PLUME MANAGEMENT KIT (7-716-191-086) replaces the plume deflector in the Ø60/100mm telescopic flue terminal.

4.5.3 Adjusting the standard terminal length:

1. Extend tube (1) by withdrawing from tube (2) to achieve the flue length required, 350- 570mm for the standard telescopic flue or 570 to 790mm for the longer telescopic flue. Secure with screw provided and seal joint with the aluminium tape supplied.

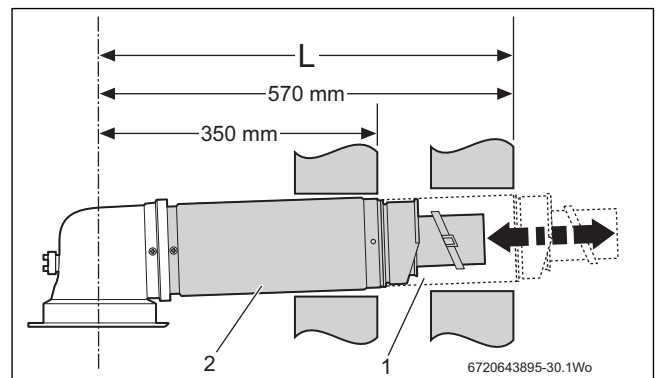

Fig. 34

Reducing the standard terminal length:

2. Remove securing screws (3) to detach the terminal assembly from the turret. Slide terminal section (2) from the terminal assembly and discard. To use terminal (1) without cutting remove the location lug (4) on the inner flue tube (5) and remove any burrs. To reduce the terminal length further:
3. Mark the length required for the terminal (6) as shown (min. 130mm) and cut square, taking care not to damage the tubes. Remove any burrs and chamfer the outer edge of the tubes to assist ease of connection and prevent seal damage.



The aluminium tape is not required when reducing the terminal.

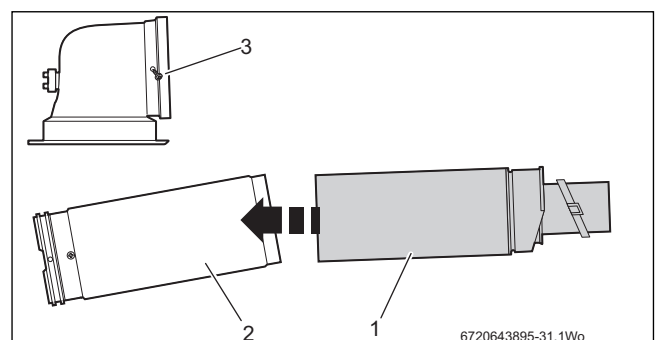

Fig. 35 Reducing the standard terminal

4.5.4 Installing the standard flue

1. Set the flue length to the distance required, secure with screw and seal joint with the aluminium tape supplied.
Slide the inner wall seal (1) onto the terminal (2) as shown.
If fitting from inside the building; slide the outer wall seal (3) onto the terminal (2) as shown.

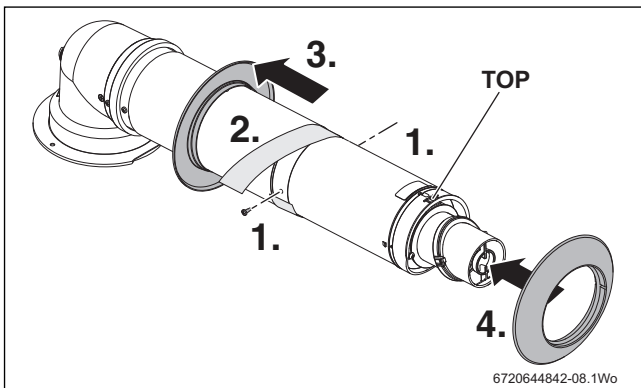

Fig. 36

2. Remove the three screws (4, 8) around the flue outlet (6) on the boiler. See screw pack in boiler.
Check the boiler flue seal is correctly seated.
Apply silicone grease to the boiler flue seal.
3. Position terminal (2) through the flue opening in the wall to the outside of the building by the distance shown.
The flue terminal MUST be fitted with the 'TOP' uppermost to allow the correct fit and use of the plume management system.
4. Align the flue turret (5) to the boiler flue outlet (6) with flat (7) facing to the rear of the boiler.
Push the flue turret (5) straight down into the boiler flue outlet (6).
For ease of assembly, locate screw (8) first and then fit screws (4) to secure flue turret (5).
If fitting from the outside of the building; slide the outer wall seal (3) onto the terminal (2) as shown.

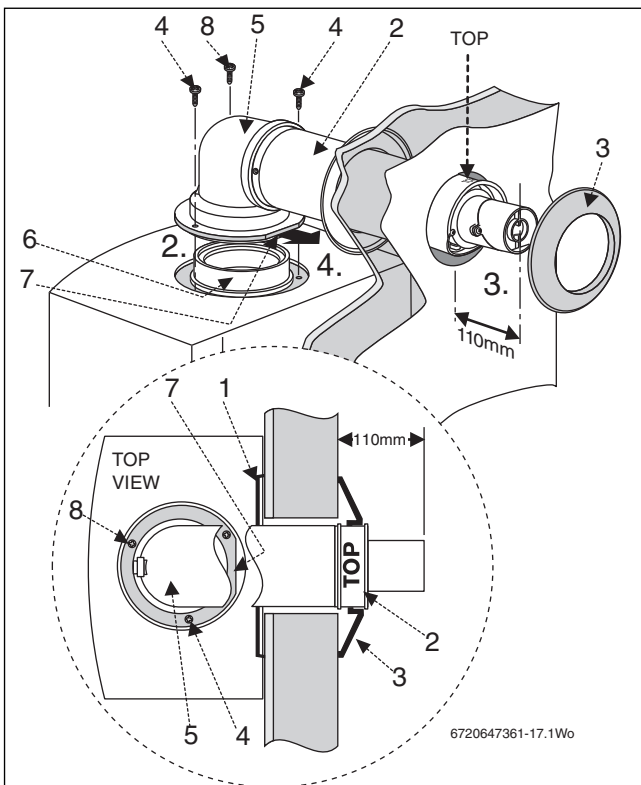



Fig. 37

4.5.5 Flue terminal plume re-direction:

The flue discharge can be re-directed allowing some plume redirection control, alternatively, a complete plume management system can be fitted to the flue terminal.

RE-DIRECTING THE FLUE DISCHARGE

1. Using a suitable tool, release the clips (1 & 2) the terminal end and rotate through 180°.

 **NOTICE:** DO NOT rotate the complete terminal assembly.

1. Refit to the terminal, ensuring that the clips (1 & 2) are engaged and secure.
2. Loosen screws (3) and rotate the entire outlet assembly to redirect the plume. Tighten screws (3) to secure in the required position.

 The flue terminal outlet has built-in stops to limit rotation for horizontal flues to allow condensate to run back into the boiler for safe disposal. Do not attempt to force beyond the limit stops.

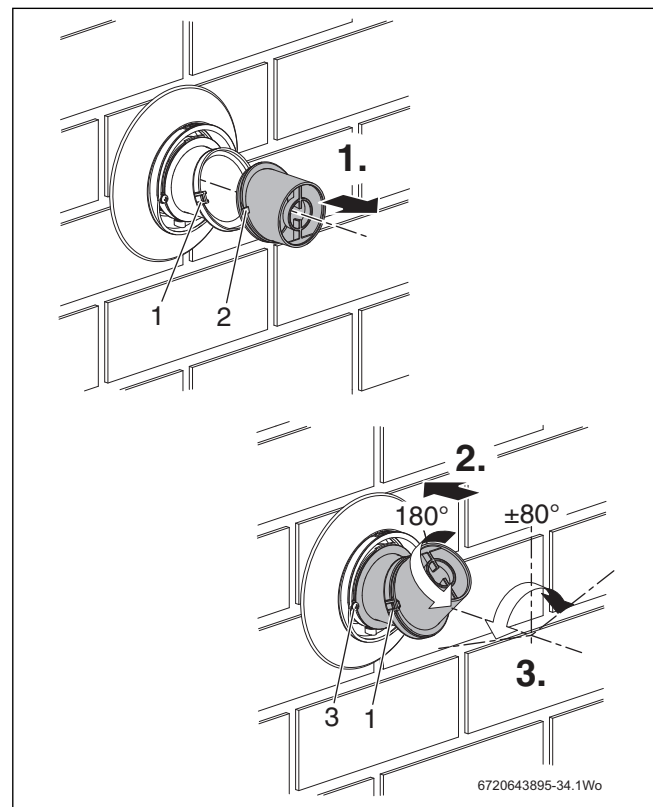



Fig. 38 Plume redirection

 **NOTICE: Outlet position**
▶ The flue terminal outlet position must follow those stated in the relevant appliance instruction manual. When redirecting the flue discharge the outlet terminal must be at least 1500mm from any opening in the direction of the discharge to prevent combustion products from entering the building.

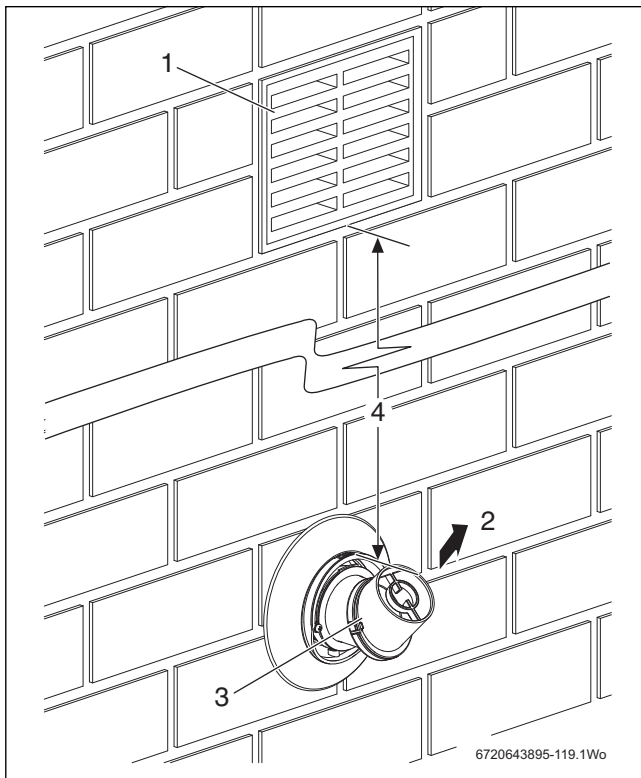

Fig. 39 Plume distance to opening

1	Opening in building
2	Flue discharge
3	Plume deflector
4	Minimum 1500mm from an opening in the building

Table 27 Key to figure 39

4.6 Condensate connection

Never terminate or discharge into any open source, including; sink, bath, shower, bidet, toilet etc.



Any external condensate pipe work of excessive runs should be protected with weather resistant insulation to help prevent freezing.

- ▶ Ensure that the condensate drain is 22mm diameter plastic pipe. It must fall at least 52mm per metre towards the outlet
- ▶ Refer to figure 40, condensate connection:
- ▶ Align the installation side plastic pipework through the pre-plumbing manifold.
- ▶ Connect the installation side plastic pipework to the end of the condensate hose.
- ▶ Push the plastic pipework inside the condensate hose at least 25mm.

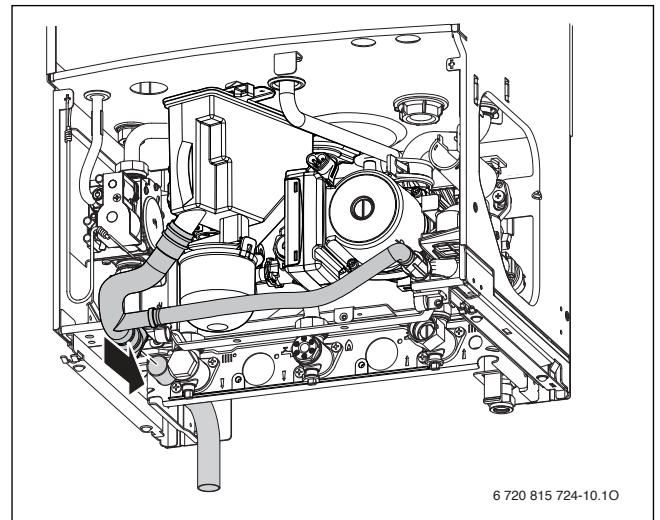

Fig. 40 Condensate connection

4.7 Electrical (without diverter valve)



CAUTION: ISOLATE THE MAINS ELECTRICITY SUPPLY BEFORE STARTING ANY WORK AND OBSERVE ALL RELEVANT SAFETY PRECAUTIONS

Danger of short circuit: When connecting the cables ensure that no cable pieces fall into the Heatronic.



Mains supply to the boiler must be through a fused double pole isolator situated adjacent to the appliance. The isolator must have a contact separation of 3 mm minimum in all poles.

Access to electrical connections:

- ▶ Remove boiler casing to access control panel.
- 1. Press in the centre of the white plastic clip securing the control panel, slide down to release and lower into the service position.
- 2. Unscrew the three screws (B) on the back of the control panel and pull off the connections cover.
- 3. Unclip the cable clamp (C).
- 4. Cut off the tapered cable entry to fit cable diameter required.
- 5. Turn cable retaining screw (D) anti-clockwise. Run cable over the main crossbar and through the cable clamp (C), ensuring there is ample cable to reach the connectors. Turn cable clamping screw (D) clockwise to secure cable and replace clamp (C) into control panel.
- 6. Mains power 230 V connection (ST10) pre-mounted:
 - ▶ Separate wires from cable end and strip to 6mm
 - ▶ Connect LIVE wire to terminal (L)
 - ▶ Connect NEUTRAL wire to the terminal (N)
 - ▶ Connect EARTH wire to the earth connector (⊕)



Earth cable to be longer so that it pulls out last if mains cable is snagged.

- 7. 230 Volt room thermostat and/or external timer (ST10):
 - ▶ Remove link
 - ▶ Connect room thermostat LIVE supply to terminal (LS)
 - ▶ Connect room thermostat SWITCHED LIVE return to terminal (LR)
 - ▶ Connect room thermostat NEUTRAL to terminal (NS)
- 8. Refit control panel cover:
 - ▶ Refit panel and secure with screws (B).
 - ▶ Bring the control panel to its upper position and secure by sliding the white plastic clip up.



- ▶ External diverter valve(s) and all other 230 V parts are not supplied with the boiler.
- ▶ A fascia mounted programmer/timer should not be fitted unless optional integral diverter valve is used.
- ▶ Refer to manufacturers instructions when connecting external parts to the wiring centre. Worcester, Bosch Group cannot be held responsible for wiring errors.

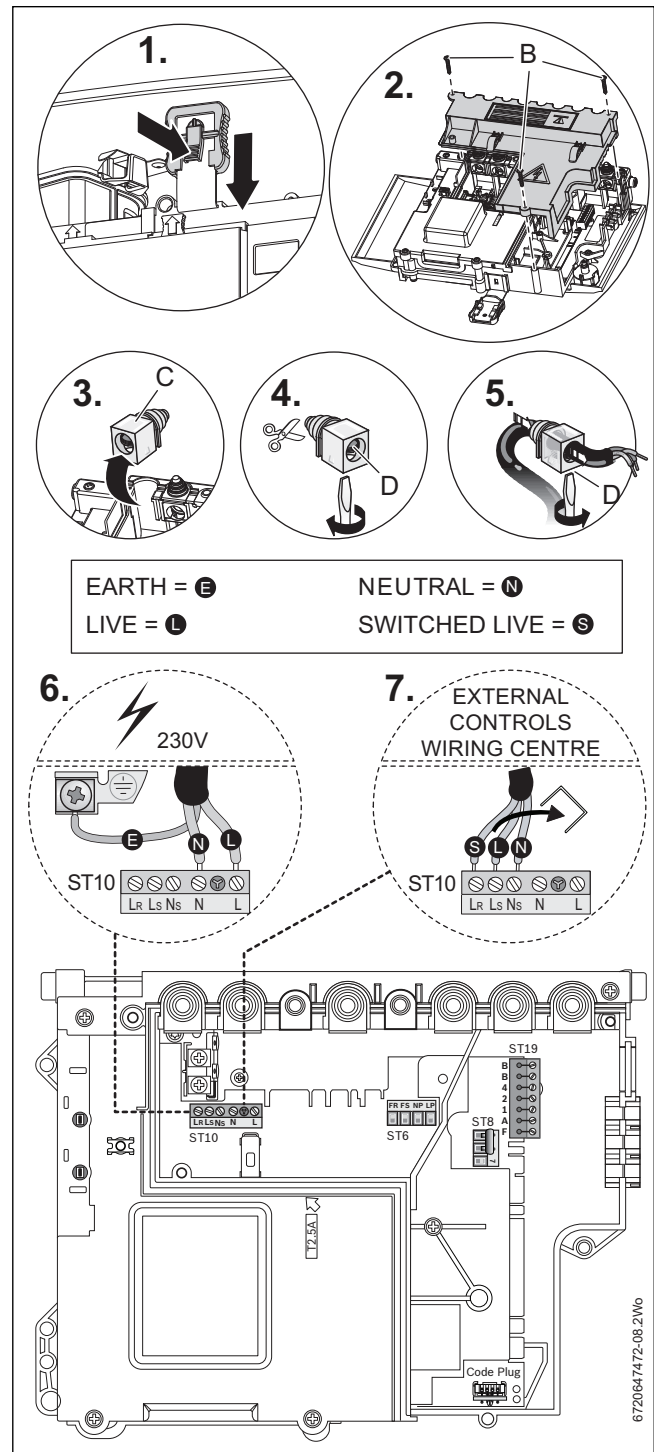



Fig. 41 Electrical connections

4.8 Electrical (with optional diverter valve)

 **CAUTION:** ISOLATE THE MAINS ELECTRICITY SUPPLY BEFORE STARTING ANY WORK AND OBSERVE ALL RELEVANT SAFETY PRECAUTIONS

Danger of short circuit: When connecting the cables ensure that no cable pieces fall into the Heatronic.

 Mains supply to the boiler must be through a fused double pole isolator situated adjacent to the appliance. The isolator must have a contact separation of 3 mm minimum in all poles.

Access to electrical connections:

- ▶ Remove boiler casing to access control panel.
- 1. Press in the centre of the white plastic clip securing the control panel and slide down to release.
- 2. Unscrew the three screws (B) on the back of the control panel and pull off the connections cover.
- 3. Unclip cable clamp (C).
- 4. Cut off the tapered cable entry to fit cable diameter required.
- 5. Turn cable retaining screw (D) anti-clockwise.
Run cable over the main crossbar and through the cable clamp (C), ensuring there is ample cable to reach the connectors. Turn cable clamping screw (D) clockwise to secure cable and replace clamp (C) into control panel.
- 6. Mains power 230 V connection (ST10) pre-mounted:
 - ▶ Separate wires from cable end and strip to 6mm
 - ▶ Connect LIVE wire to terminal (L)
 - ▶ Connect NEUTRAL wire to the terminal (N)
 - ▶ Connect EARTH wire to the earth connector

 Earth cable to be longer so that it pulls out last if mains cable is snagged.

7. Optional external frost thermostat connection (ST6):

- ▶ Connect frost thermostat supply wire to terminal (FS)
- ▶ Connect frost thermostat return wire to terminal (FR)

 Do not break the link on terminals 8 and 9 of ST8. The cylinder stat must be volt-free, i.e. not connected to any voltage source.

Do not set the cylinder thermostat to temperatures above 70°C, to avoid very long cylinder heating periods without CH function.

8. Cylinder thermostat or cylinder temperature sensor:

- a: Hot water channel Volt free cylinder thermostat (ST8), cylinder thermostat wires to terminals 7 and 9.
- b: Hot water cylinder temperature sensor (ST15), connect the included plug to the cable.
Snap out the plastic tongue and insert the cable.
- Insert the plug on the PCB at ST15.

9. Refit control panel cover:

- ▶ Refit panel and secure with screws (B).
- ▶ Bring the control panel to its upper position and secure by sliding the white plastic clip up.

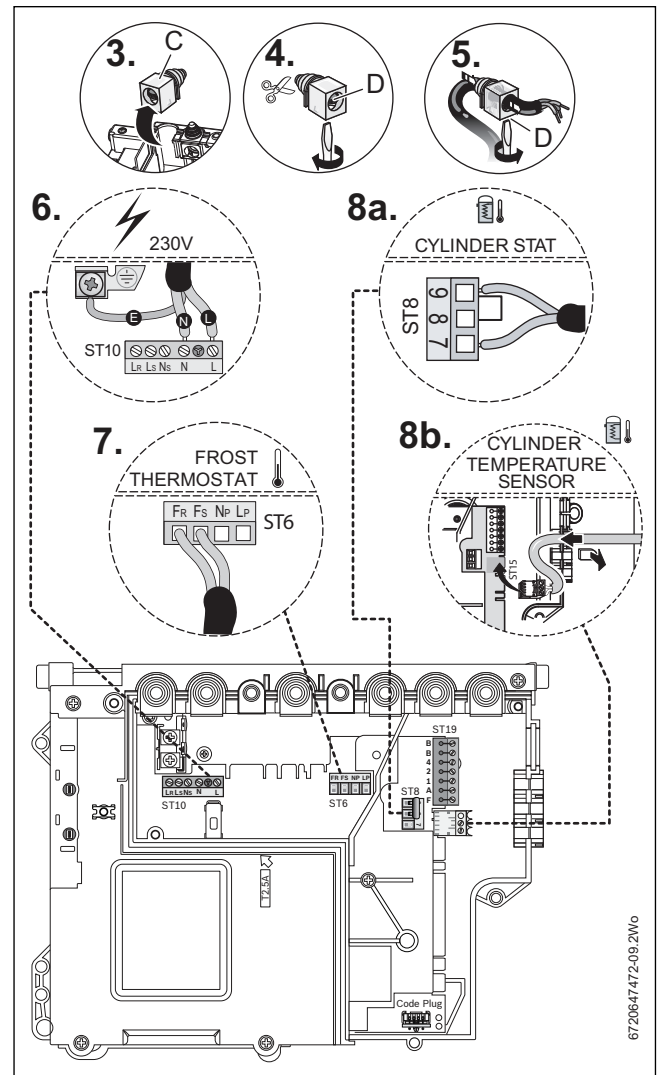

Fig. 42

4.9 Position of wired components

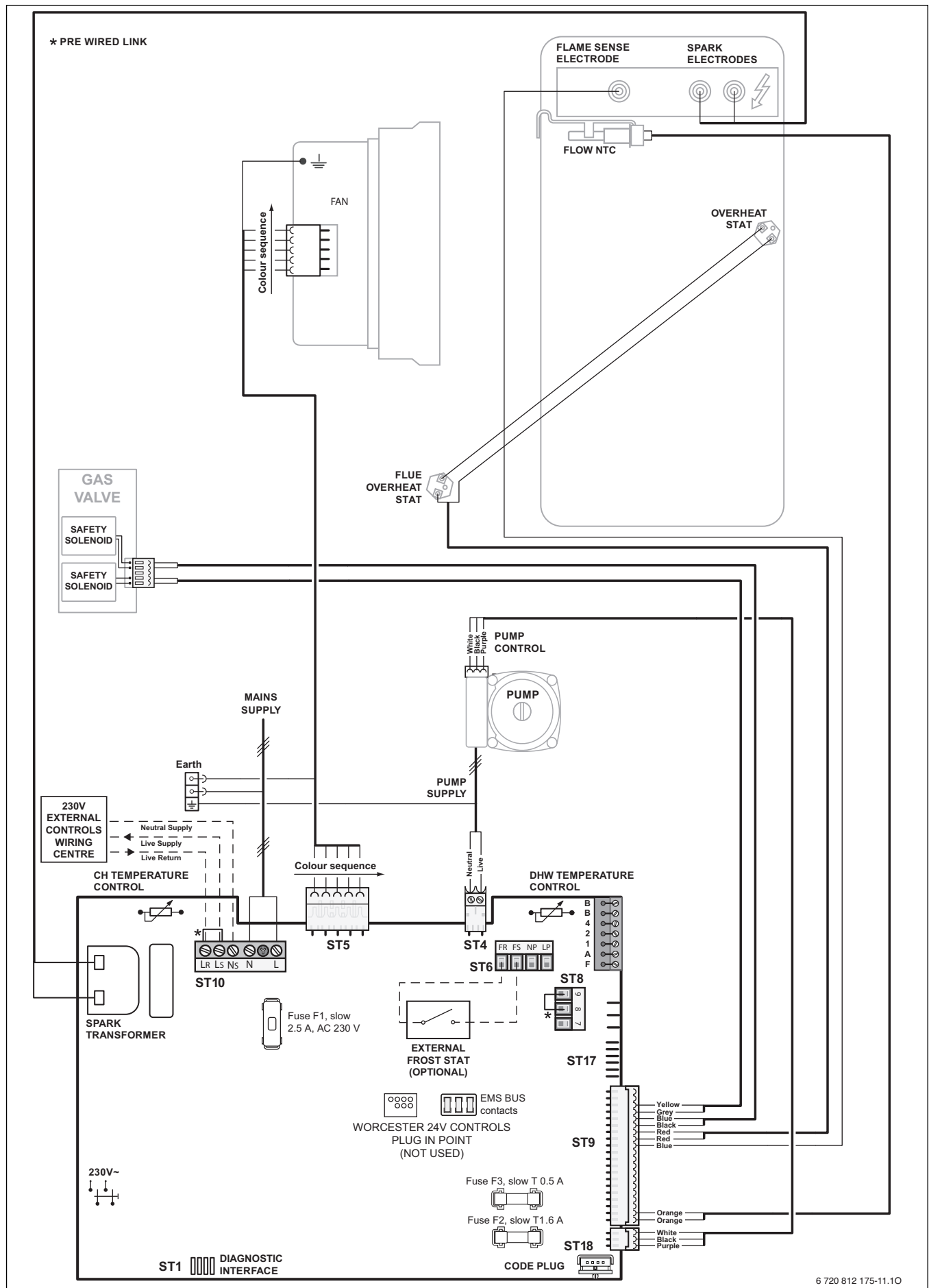

Fig. 43

5 COMMISSIONING

5.1 Pre-commissioning checks

CAUTION: MAINS SUPPLIES

▶ Isolate the mains supplies before starting any work and observe all relevant safety precautions.

1. Check that the service and water pipes are connected to the correct position on the manifold.
 - A - CH flow (22mm)
 - B - CH return (22mm)
 - C - Gas inlet (22mm)
 - D - Cylinder outlet (15mm) if the optional diverter valve is used.
 - E - Cylinder inlet (15mm) if the optional diverter valve is used.

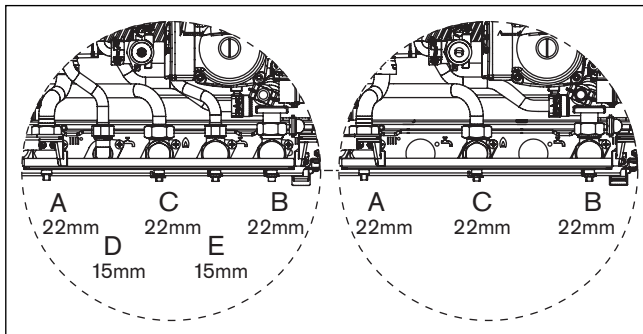

Fig. 44

2. Check the gas type specified on the identification plate (F) matches that of the gas supply. Turn on the main gas supply, check the gas pipe work, connections and rectify any leaks.

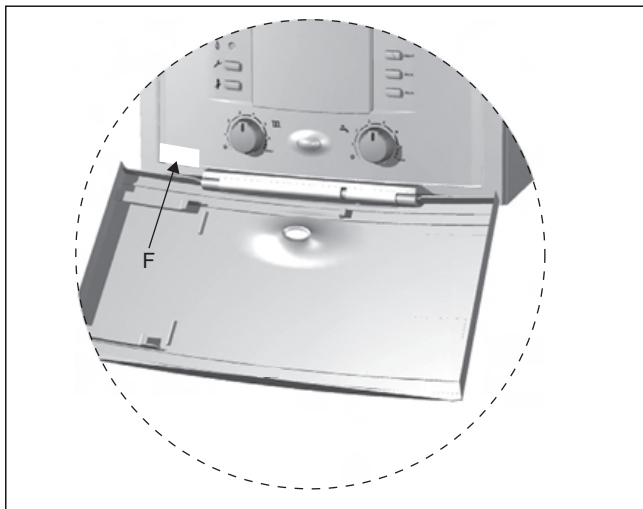

Fig. 45

3. Check that the pressure relief connector, located on the right hand side at the bottom of the wall frame, in its up position.

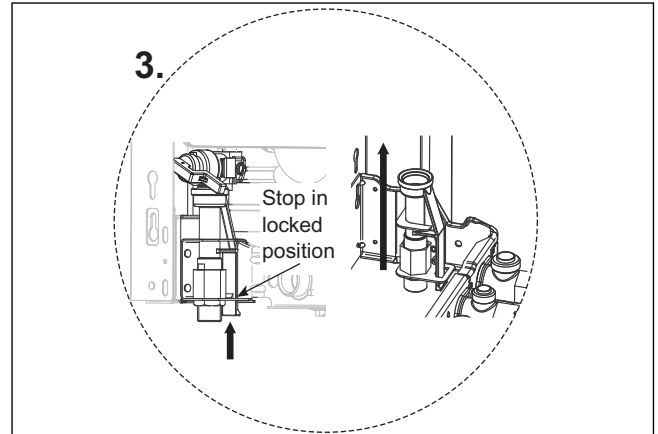

Fig. 46

4. Check that the condensate pipe has been connected to the adapter

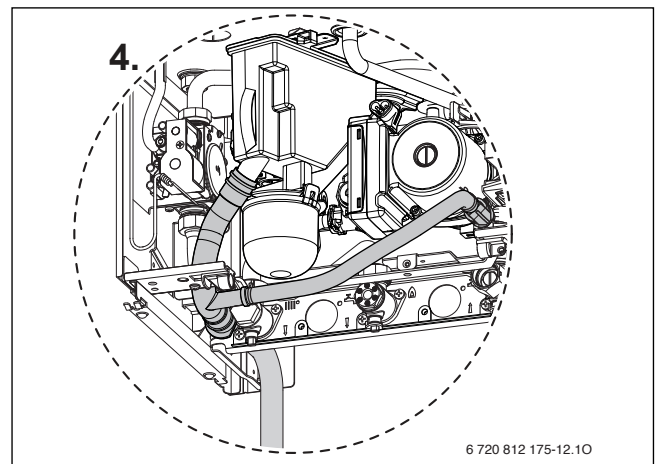

Fig. 47

NOTICE: If the boiler is not to be commissioned immediately then: after successfully completing all of the checks and any rectification work, close the gas and water valves, shut off the gas supply and electrically isolate the boiler.

5.2 Filling the system

1. Ensure all system and boiler drain points are closed.
2. For sealed systems fill the system using a WRAS approved filling loop to a pressure of 1 bar.
3. Vent all radiators, retighten when completed and check the system and correct any leaks.
 - The boiler integral expansion vessel is precharged to 0.75bar (equal to a static head of 7.5meters [22ft]). A Schraeder type valve is fitted to the expansion vessel to allow for pressure adjustment if required.
 - If an extra expansion vessel is fitted to the central heating return, adjust to the **same pressure** as the appliance internal expansion tank, refer to separate instructions with the extra expansion vessel.
4. Briefly open the pressure relief valve to test its operation.
5. Refill the system up to 1 bar.

GAS SUPPLY

- ▶ Open gas cock on the boiler and purge the gas supply to the boiler ensuring that the room is well ventilated.
- ▶ Test gas supply for soundness as described in BS 6891.

5.3 Starting the appliance

 **NOTICE:** Never run the appliance when the appliance/system is empty or partially filled.

SWITCHING THE APPLIANCE ON/OFF:

1. Turn on mains power supply.
 - ▶ Turn on any external controls.
 - ▶ Set the thermostatic radiator controls to maximum temperature.
 - ▶ Set the clock/programmer to continuously ON and the room thermostat to maximum temperature.

A	On/off button
B	Cover or position for optional plug-in control
C	Display
D	System pressure gauge
E	Reset button
F	ECO button (only with optional diverter valve)
G	Holiday button (only in conjunction with optional diverter valve)
H	DHW temperature control (only with optional diverter valve)
I	Central heating temperature control
J	Performance test button
K	Service button
L	Burner indicator (GREEN)
M	On/off and fault indicator (BLUE)
N	Auto Air Vent

Table 28

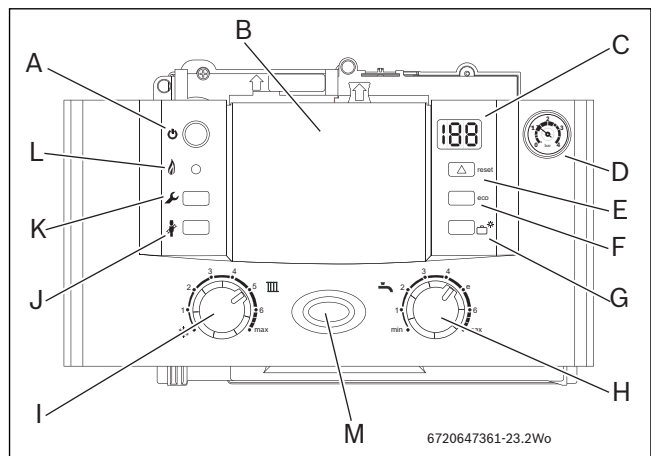



Fig. 48 Control panel

- ▶ Press button (A) and the power on indicator (M) illuminates BLUE. After a few seconds the display will show the flow temperature.
2. Turn the CH temperature control (I) to maximum. The burner on indicator (L) illuminates GREEN when the burner has lit.



- ▶ The first time the appliance is switched on, a once-only venting function is activated. The heating pump then switches on and off at intervals. This sequence lasts about 8 minutes. The display shows $\circ\text{O}$ in alternation with the CH flow temperature. The automatic air vent (N) must be open, please verify.
- ▶ The boiler runs for 15 minutes at minimum heating output to fill the condensate trap, the display (C) alternates between “-II-” and the central heating flow temperature. This occurs every time the mains supply has been interrupted.

3. If the boiler fails to light the BLUE power indicator (M) and reset button (E) will flash alternately. To reset press and hold the reset button (E) for 2 seconds. The boiler will be reset.

 **CAUTION:** DO NOT PRESS POWER INDICATOR (B) TO RESET BOILER.

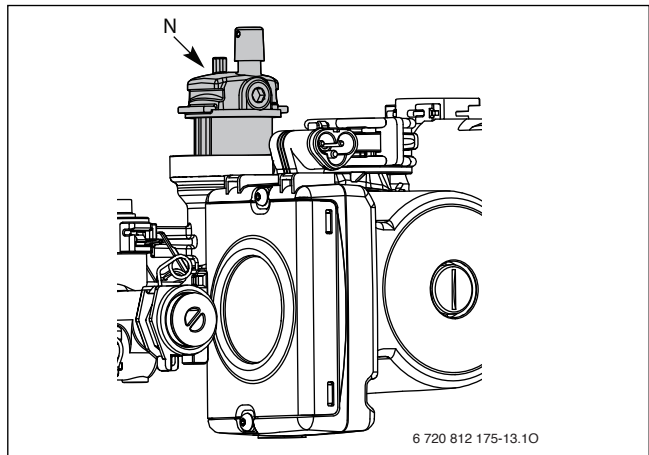



Fig. 49 Auto Air Vent

5.4 Water treatment

 **NOTICE:** Debris from the system can damage the boiler and reduce efficiency. Failure to comply with the guidelines for the use of water treatment with the appliance will invalidate the appliance warranty. Ensure that the system has been cleaned as on page 10.

FLUSHING (Central Heating):

1. Switch off the boiler.
 - ▶ Open all drain cocks and drain the system while the appliance is hot.
2. Close drain cocks and add a suitable flushing agent at the correct strength for the system condition in accordance with the manufacturer's instructions.
3. Run the boiler/system at normal operating temperature for the time stated by the manufacturer of the flushing agent.
4. Drain and thoroughly flush the system to remove the flushing agent and debris.

INHIBITOR (Central Heating):

5. Check drain cocks are closed and all radiator valves are open before adding a suitable¹⁾ inhibitor (or combined inhibitor/anti-freeze if the system is exposed to freezing conditions) to the heating system water in accordance with the manufacturers instructions.
6. Fill via a WRAS approved filling loop to between 1 and 2 bar.
7. Vent all radiators; retighten vents when complete.
8. Re-pressurise if necessary to 1bar.
 - ▶ Set all controls to maximum.
 - ▶ Record the date when the inhibitor was added to the system on the guarantee card.

1) **Compatible with aluminium. The pH value of the system water must be less than 8 or the appliance guarantee will be invalidated.**



- ▶ The concentration level of inhibitor in the system should be checked every 12 months or sooner if system content is lost.
- ▶ The addition of sealing agents to the system water is not recommended as this can cause problems with deposits left in the heat exchanger.

Water treatment products

Suitable water treatment products can be obtained from the following manufacturers:

FERNOX	0870 601 5000 www.fernox.com
SENTINEL	0800 389 4670 www.sentinel-solutions.net

Table 29

5.5 Commissioning



When fitted with the optional diverter valve (not supplied) and running in performance test mode, the boiler will only operate the central heating circuits. If fitted to an S or Y plan system, the system must only be run in central heating mode. This is to allow sufficient time for this part of the commissioning procedure.

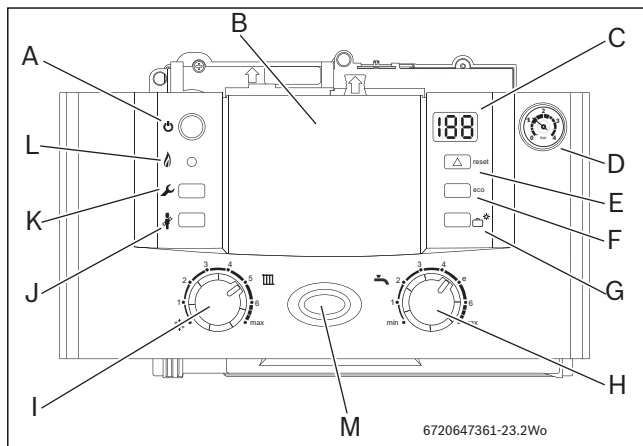

Fig. 50 Control panel

A	On/off button
B	Cover or position for optional plug-in control
C	Display
D	System pressure gauge
E	Reset button
F	ECO button (only with optional diverter valve)
G	Holiday button (only with optional diverter valve)
H	DHW temperature control (only with optional diverter valve)
I	Central heating temperature control
J	Performance test button
K	Service button
L	Burner indicator (GREEN)
M	On/off and fault indicator (BLUE)
N	Auto Air Vent

Table 30



NOTICE: THE COMBUSTION FOR THE APPLIANCE IS FACTORY SET. NO ADJUSTMENT IS REQUIRED IF THE GAS INLET PRESSURE IS CORRECT.

5.5.1 Checking the gas inlet pressure

The inlet pressure to the appliance must be checked using the following procedure:

MEASURING THE INLET PRESSURE

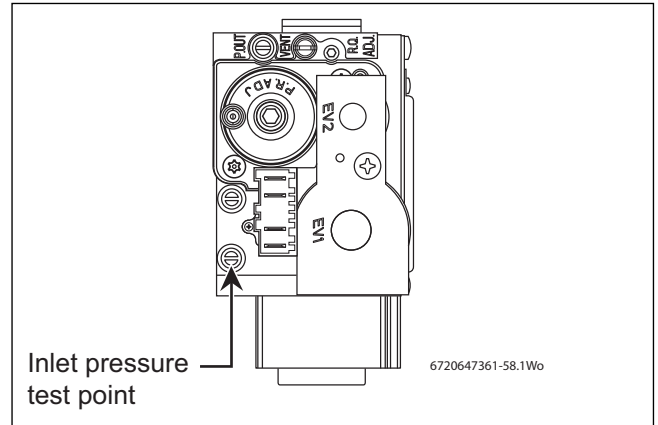

Fig. 51 Inlet pressure test point

- ▶ Close gas isolation valve.
- ▶ Slacken the screw in the inlet pressure test point and connect a manometer.
- ▶ Open gas isolation valve.
- ▶ Measure the pressure with the boiler running at maximum.
 - Press Performance test button (J) for more than ten seconds and set Central Heating temperature to maximum.
 - The Performance test button (J) will illuminate continually and the display (C) will alternate between and and the central heating flow temperature.
- ▶ Check the gas supply working pressure at the gas valve conforms to values shown in Fig. 52 or Fig. 53 .



Ensure inlet pressure is satisfactory with all other gas appliances working.



NOTICE: Do not continue commissioning until the correct gas inlet pressure is achieved.

- ▶ If the gas pressure is satisfactory, press the Performance test button (J) again and the boiler will return to normal operation. If left in Performance test mode, the control will return to normal operation after 15 minutes.
- ▶ Close the gas isolation valve and remove the manometer.
- ▶ Re-seal the screw in the gas inlet pressure test point.
- ▶ Open the gas isolation valve and check for gas tightness.

Gas pressure within the system

Refer to the figure below for natural gas pressures.

The pressure at the boiler must not be less than the pressure read at the meter minus 1 mbar.

The pressure drop from the meter to the gas valve must not be more than 2.5 mbar for natural gas.

If the pressure drops are greater than shown in fig. 52, this indicates a problem with the pipe work or connections within the system.

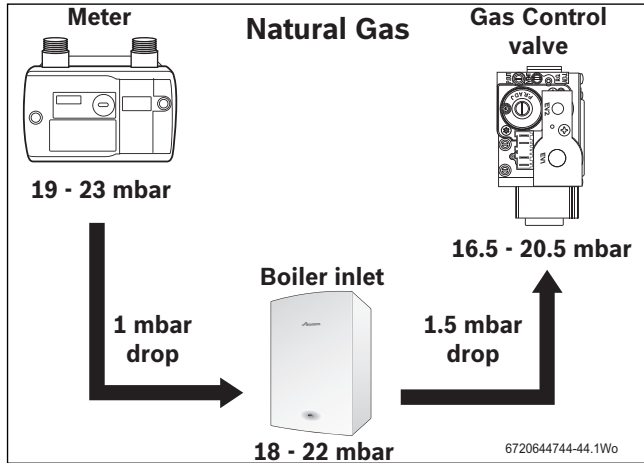

Fig. 52 Natural gas pressures

Refer to the figure below for L.P.G gas pressures.

The pressure at the boiler must not be less than the pressure read at the meter minus 2.5 mbar.

The pressure drop from the meter to the gas valve must not be more than 4 mbar for LPG.

If the pressure drops are greater than shown in figure 53, then this would indicate a problem with the pipe work or connections within the system.

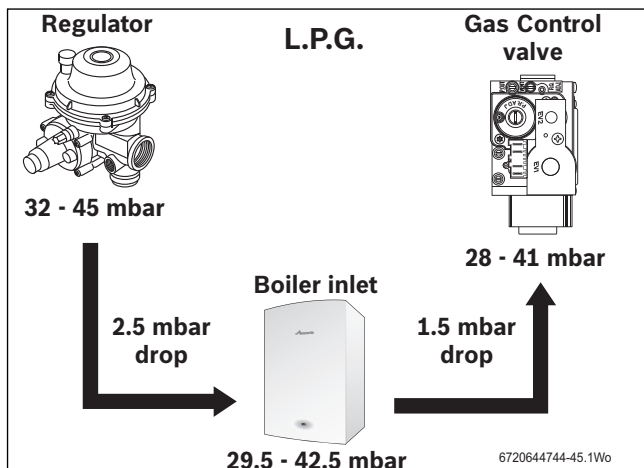

Fig. 53 L.P.G. pressures

NOTICE:
Do not continue commissioning until the correct gas pressure is achieved.

- ▶ If pressure is satisfactory press the performance test button (J) again and the boiler will return to normal operation.
- ▶ If left in the central heating boost mode the control will return to normal operation after 15 minutes.
- ▶ Re-seal the screw in the gas inlet pressure test point.

5.5.2 Checking the gas rate

- ▶ The gas rate should be measured at the gas meter after 10 minutes operation at maximum.
See technical data section at the front of this manual.
- ▶ Where a gas meter is not available (e.g. L.P.G.) the CO/CO₂ must be checked to the units shown in the setting of the air/gas ratio, refer to section 6.2.
- ▶ If pressure and gas rate are satisfactory press the service button again and the boiler will return to normal operation.
 - If left in the service mode the control will return to normal operation after 15 minutes.
- ▶ Close the gas isolation valve.
- ▶ Remove the manometer.
- ▶ Re-seal the screw in the gas inlet pressure test point.
- ▶ Open the gas isolation valve.
- ▶ Ensure that there are no gas leaks.
- ▶ Replace the outer case.

5.6 CO and Combustion checks

The following combustion and flue integrity checks will be mandatory from April 2014 and these values must be recorded on the Benchmark check list, at the back of this manual.

Once the gas rate and pressure have been confirmed as acceptable, then the CO and combustion checks can be undertaken.

The flow chart is given for guidance; the details of the checks are given in the following sections:

- Checking flue integrity, refer to section 6.1.1, page 37
- Setting the air/gas ratio, refer to section 6.2, page 41
- ▶ Use the attached Benchmark checklist and service record to record the Commissioning and Servicing details.



NOTICE: BEFORE CO AND COMBUSTION CHECKS:

- ▶ Refer to section 5.5.1 and 5.5.2 to verify gas type, gas inlet pressure, and gas rate. Visually check the integrity of the whole flue system and confirm that all the components are correctly assembled, fixed and supported.
- ▶ The flue gas analyser must be the correct type as specified in BS 7967. Before use the analyser must have been calibrated as specified by the manufacturer. The installer must be competent in the use of the analyser. Check and zero the analyser in fresh air as specified by the manufacturer.
- ▶ The air/gas ratio valve is factory set and must not be adjusted during commissioning unless this action is recommended following contact with the Worcester, Bosch Group help line 0330 123 3366.

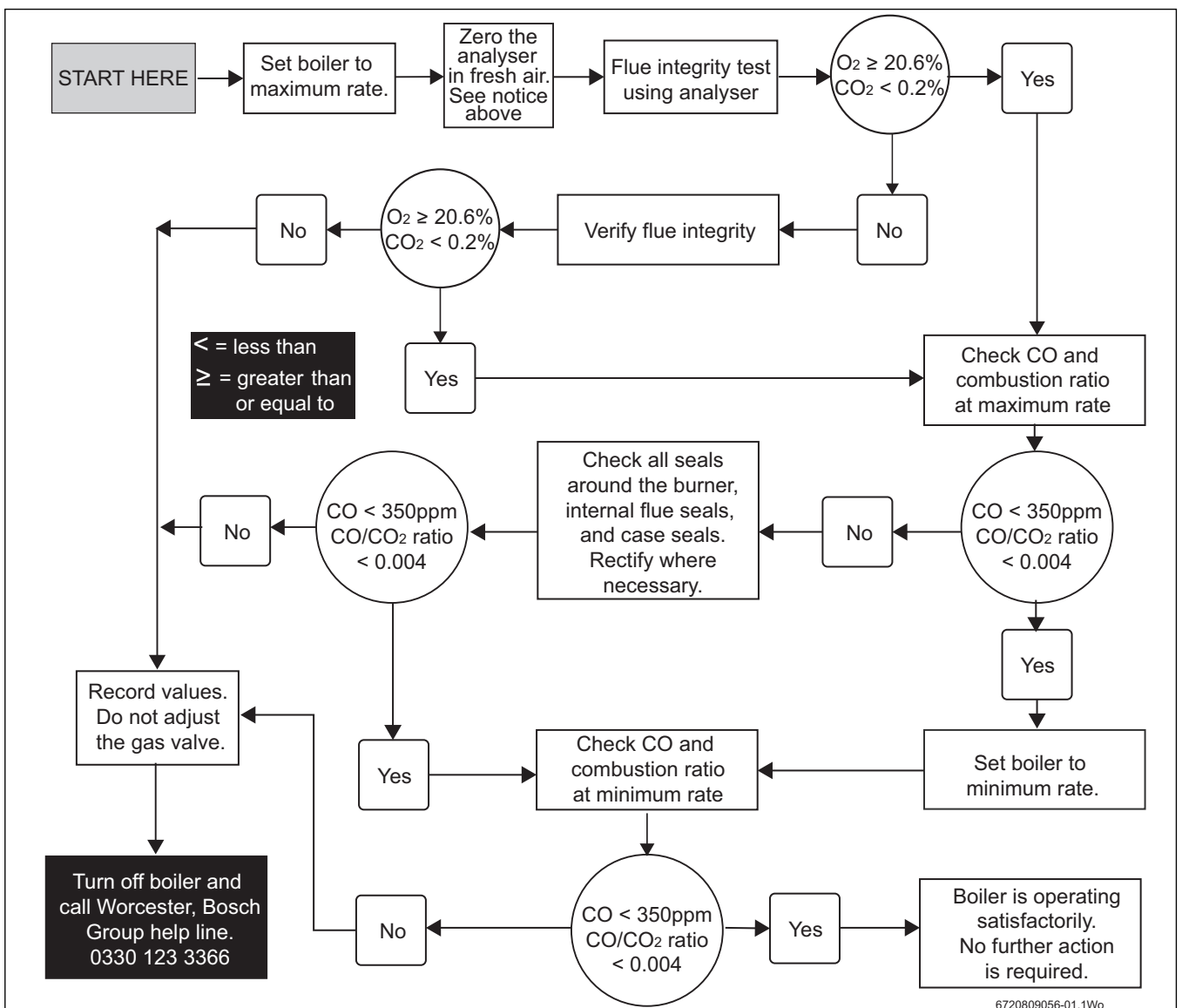

Fig. 54 Combustion check flow chart

5.7 Finishing commissioning

The boiler has been factory set, so there should be no need to adjust combustion settings.

REPLACE OUTER CASING:

1. Replace outer casing making sure that the securing points are properly located.
 - ▶ Press the clip (A) downwards to secure casing on top.
 - ▶ Retighten bottom two screws (B).

INSTALLING BOTTOM PANEL:

2. The bottom panel slides onto two ledges (C) either side of the boiler frame.
 - ▶ Hold the panel up against the underside of the boiler and slide towards the rear until it is fully engaged.

HANDOVER:

- ▶ Complete the Benchmark check list.
- ▶ The fascia cover is opened by pulling the flap (D) towards you.
- ▶ Set up the controls and show the user how to operate all the controls shown in the User Guide.
- ▶ Place the user guide into the tray (E) on the inside of the fascia cover.
- ▶ If the appliance is unused and exposed to freezing conditions; shut off all the mains supplies and drain the system and boiler.

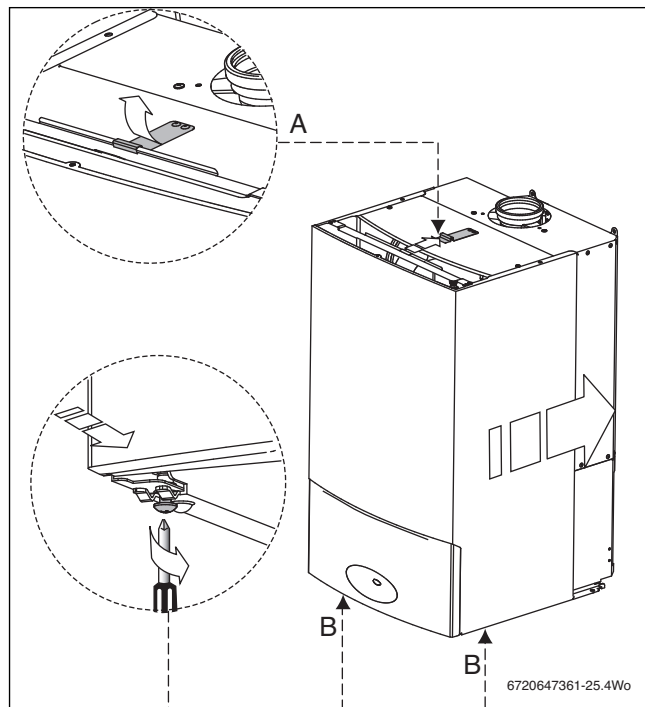

Fig. 55 Fitting outer case

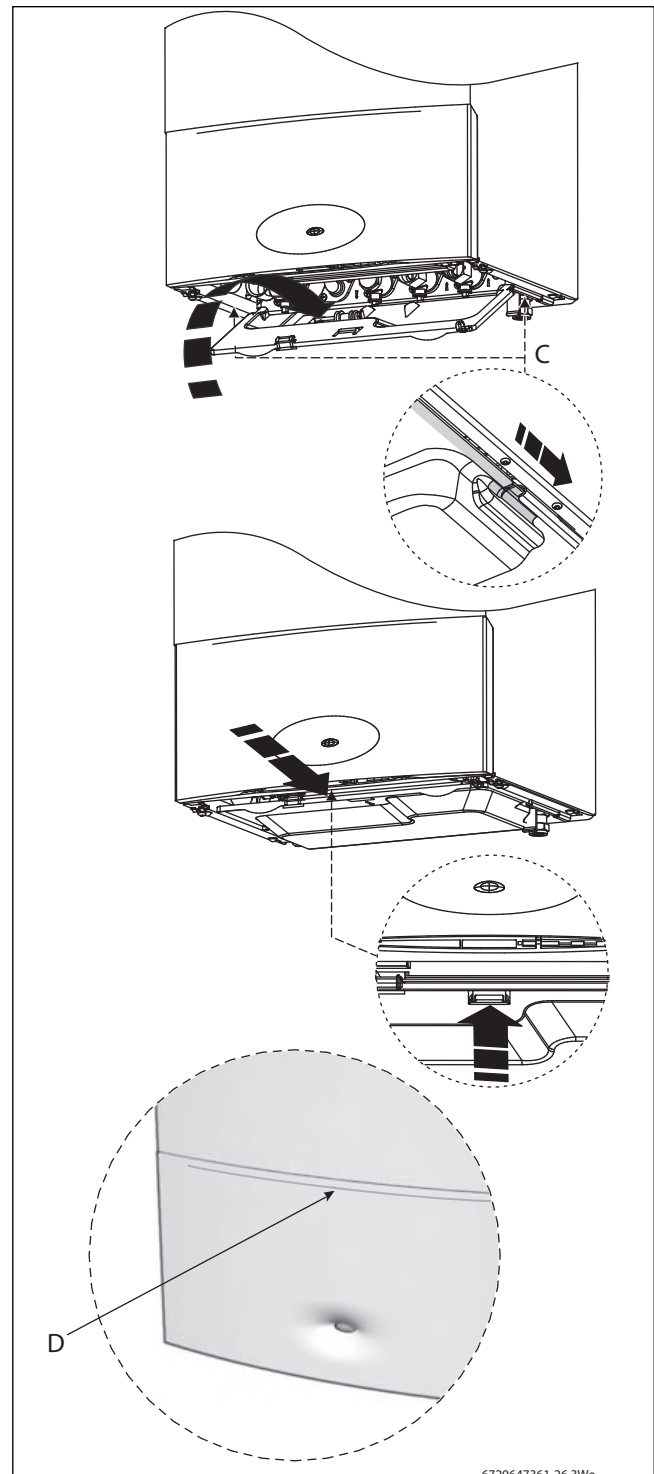

Fig. 56 Fitting bottom panel

6 SERVICING AND SPARES

6.1 Inspection and spares



CAUTION: TURN OFF THE GAS SUPPLY AND ISOLATE THE MAINS SUPPLIES BEFORE STARTING ANY WORK AND OBSERVE ALL RELEVANT SAFETY PRECAUTIONS.



NOTICE: After replacement of any components always check for gas tightness where relevant and carry out functional checks as described in the Commissioning section. Replace any O-rings or gaskets that have been disturbed.



NOTICE: Any service work must be carried out by competent Gas Safe registered engineer.

- To ensure the continued efficient operation of the appliance it must be checked at regular intervals.
- The frequency of servicing will depend upon the particular installation conditions and usage. However, an annual service is recommended.
- The extent of the service required by the appliance is determined by the operating condition of the appliance when tested by **fully qualified engineers**.

INSPECTION

1. Check that the terminal and the terminal guard, if fitted, are clear and undamaged.
 2. If the appliance is in a compartment or cupboard check that the specified service space around the appliance is clear.
 3. Check all the joints and connections in the system and remake any that show signs of leakage. Refill and re-pressurise if applicable as described in Commissioning.
- ▶ Operate the appliance and take note of any irregularities. Call up the last fault stored by the Bosch Heatronic, Service Function .0. Refer to Fault Finding for rectification procedures.

6.1.1 Checking flue integrity

The integrity of the flue system and performance of the boiler can be checked via the flue turret sample points.

Flue gas sample point	1
Air inlet sample point	2

Table 31 Key to figure 57

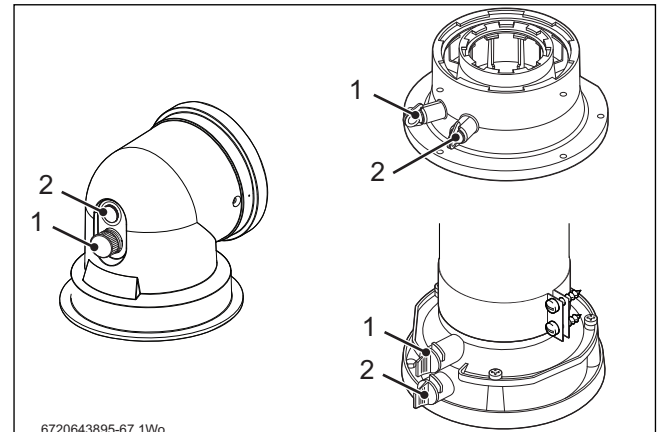

Fig. 57 Flue turret test points

With the boiler case on and the boiler running at maximum output (refer to paragraph "SET THE BOILER TO MAXIMUM", page 38).

- ▶ Ensure that the probe reaches the centre of the air intake, adjust the cone on the probe so that it seals the sample point and correctly positions the end of the probe.
- ▶ Insert the analyser probe into the air intake sample point.
- ▶ Allow the readings to stabilise and check that:
 - O₂ is equal to, or greater than 20.6%.
 - CO₂ is less than 0.2%
- ▶ If the readings are outside these limits then this indicates that there is a problem with the flue system or combustion circuit, e.g. missing or dislodged seals.

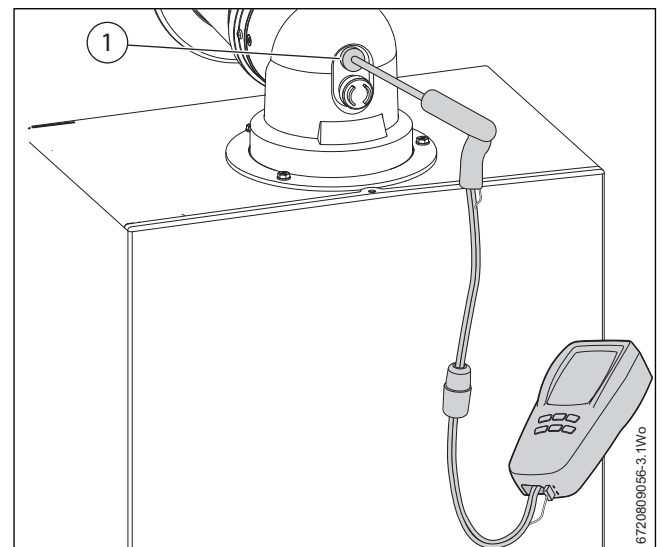

Fig. 58 Flue integrity test

6.1.2 Component access

Removing outer case

1. Remove bottom panel by pulling it forward and off.
2. Undo but do not remove the 2 screws (A) securing boiler casing at the bottom of the appliance.
3. Pull upwards to release the clip (B) on top of the boiler.
4. Pull case forward and remove.

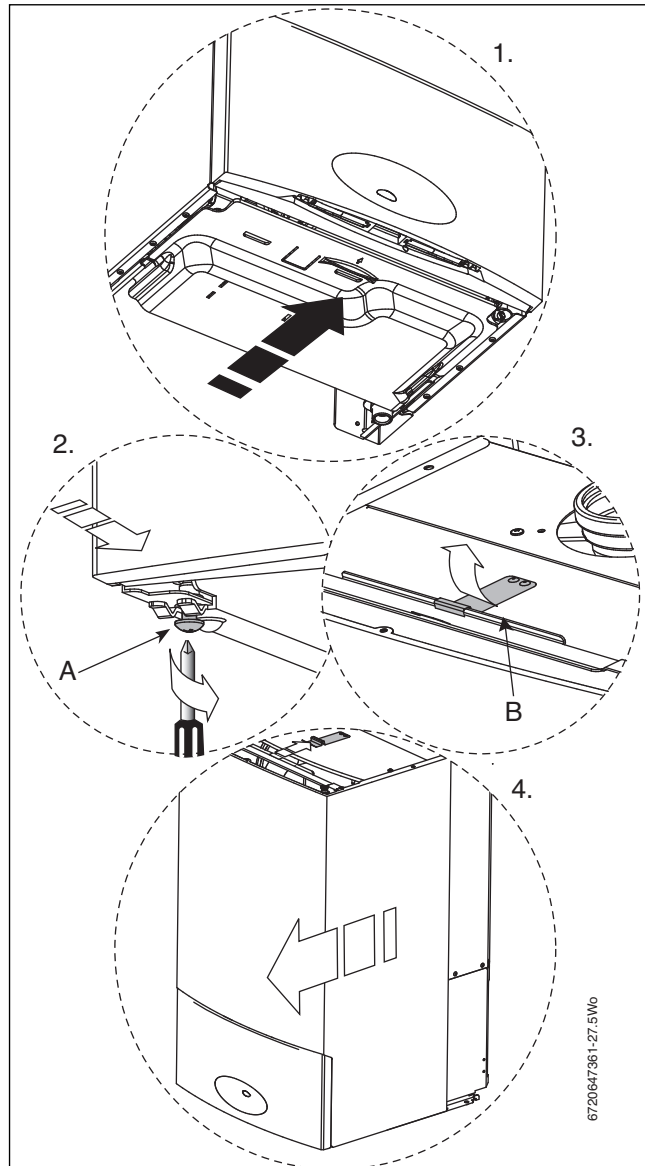

Fig. 59 Removing outer case

2. Adjusting boiler control to service position

1. Squeeze the white clip and pull down to release the control panel.
2. Pull the control panel forward until it comes to rest in service position.

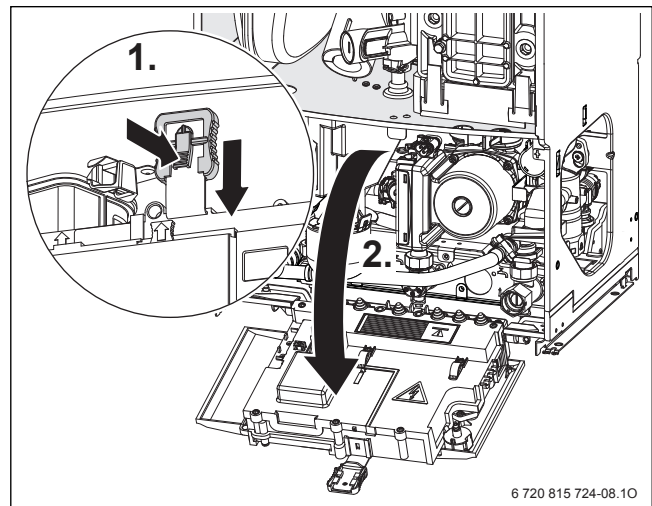

Fig. 60 Controls to service position

6.1.3 Fan pressure test



This test is to determine if the heat cell requires cleaning/attention

SET THE BOILER TO MAXIMUM



When fitted with the optional diverter valve (not supplied) and running in performance test mode, the boiler will only operate the central heating circuits. If fitted to an S or Y plan system, the system must only be run in central heating mode. This is to allow sufficient time for this part of the commissioning procedure.

A	On/off button
B	Cover or position for optional plug-in control
C	Display
D	System pressure gauge
E	Reset button
F	ECO button (only with optional diverter valve)
G	Holiday button (only in conjunction with optional diverter valve)
H	DHW temperature control (only with optional diverter valve)
I	Central heating temperature control
J	Performance test button
K	Service button
L	Burner indicator (GREEN)
M	On/off and fault indicator (BLUE)

Table 32

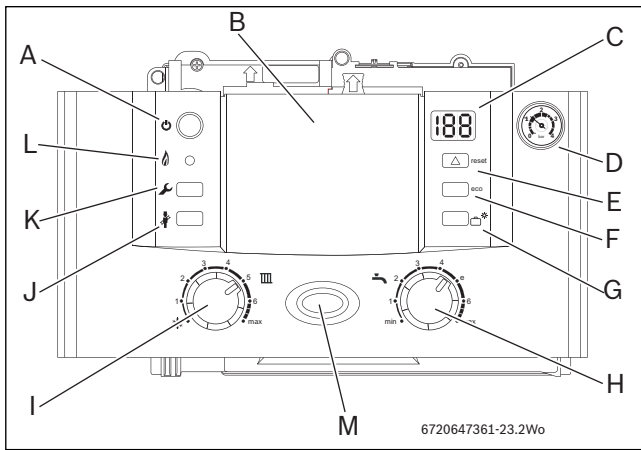

Fig. 61 Control panel

- ▶ Press and HOLD performance test button (J) for 10 seconds and set Central Heating temperature to maximum.
 - The performance test button will illuminate continually.
 - The boiler will stay in this mode for 15 minutes unless the central performance test button is pressed again.
- ▶ Pull the cover off and connect a manometer to the fan pressure test point.
- ▶ After measurement replace test point cover.

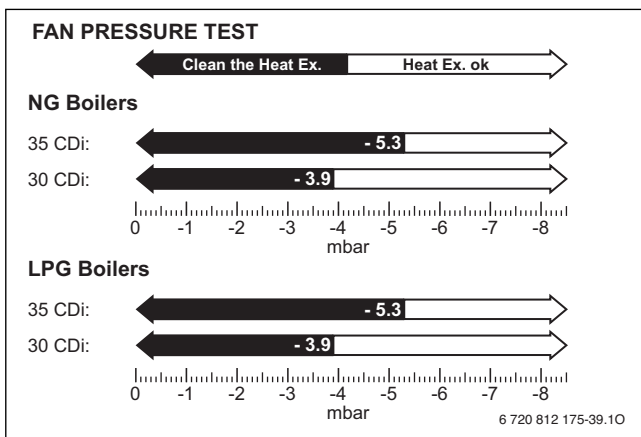

Fig. 62 Fan pressure readings

- Pressures readings in the black area will indicate that the heat exchanger requires attention/cleaning.
- There is a special accessory kit available specifically designed for cleaning the heat exchanger. Part number 7 719 001 996.

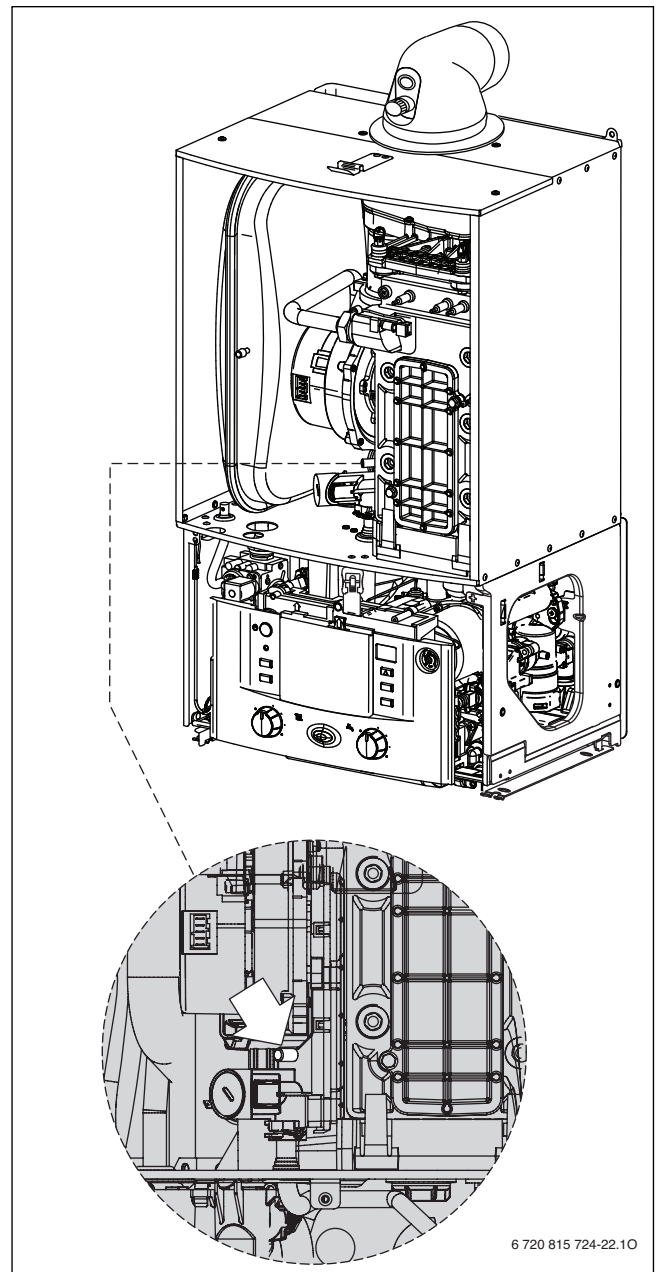

Fig. 63 Fan pressure test point



NOTICE: Air/Gas ratio

- ▶ After servicing the CO/CO₂ must be checked using the procedure in the section “Setting the air/gas ratio” on page 41.
- ▶ The setting of the air/gas ratio must be carried out by a competent person. Setting the air/gas ratio must not be attempted unless the person carrying out the conversion is equipped with a combustion analyser conforming to BS 7927 and is competent in its use.

6.1.4 To Clean the Heat Exchanger

- ▶ Remove outer case and base panel and isolate the appliance from power.
1. Remove cleaning access cover (B), seal (C) and metal plate (D) securing it, if present.

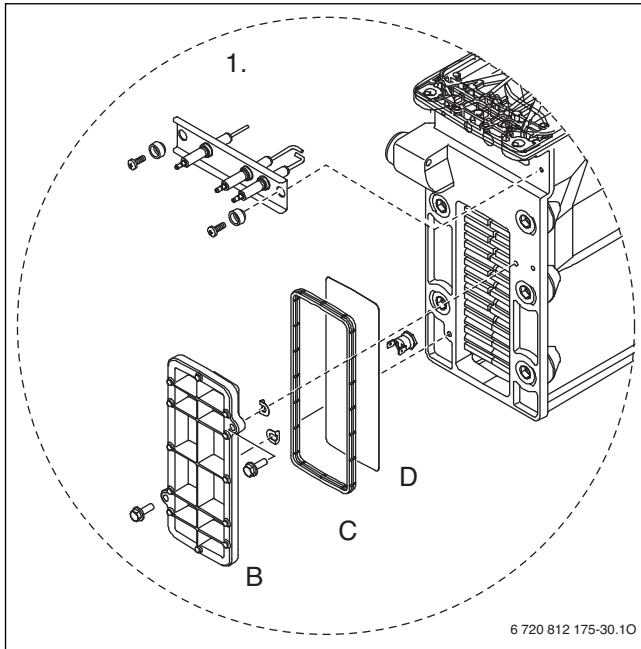

Fig. 64 Cleaning the heat exchanger

2. Loosen any deposits in the heat exchanger from top to bottom using the cleaning blade.

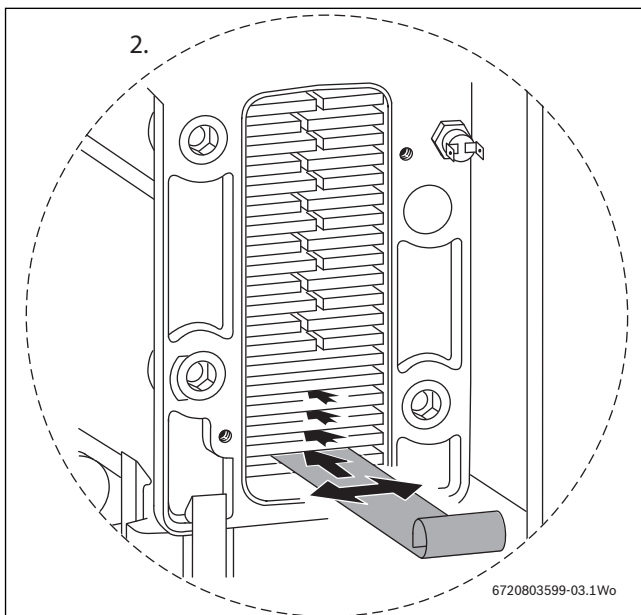

Fig. 65

3. Clean the heat exchanger from top to bottom using the brush.

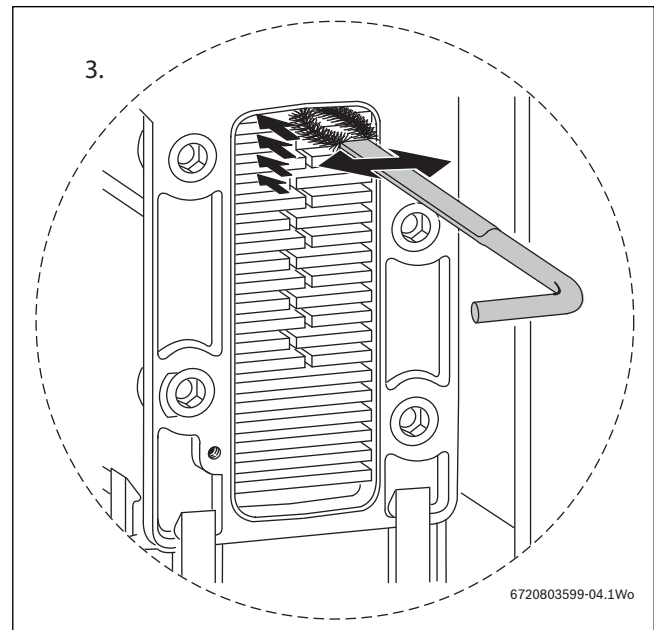

Fig. 66

- ▶ Refit the clean out cover plates in reverse order using a new seal (C) and tighten screws.

6.1.5 To Clean the Burner

1. Remove cover panel (A) by removing the screws (B).
- ▶ Check that the boiler is completely isolated from the gas supply.

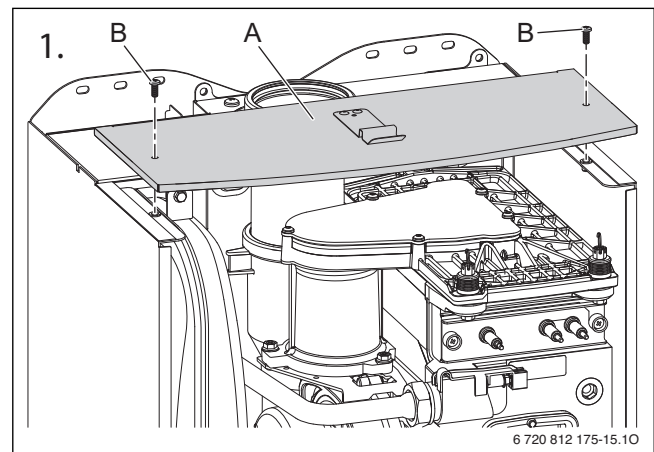

Fig. 67

2. Remove the clips (C) and unscrew the two bolts (D).
- ▶ Unscrew and remove the two hexagon screws (E) securing the fan.
- ▶ Slacken fully the rear securing bolt (F).
- ▶ Remove the burner cover plate (G).

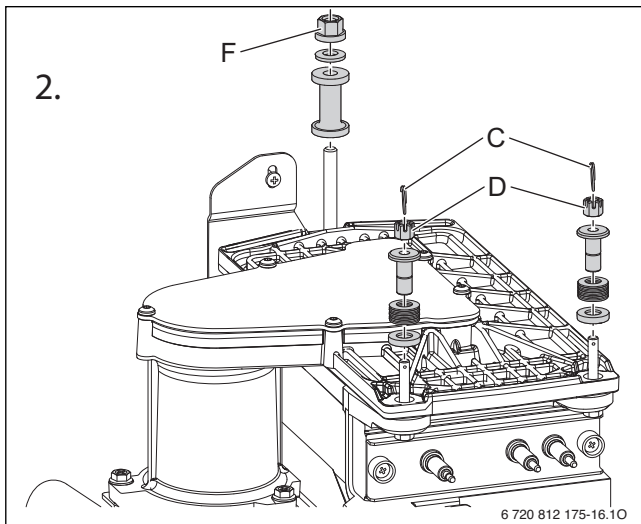

Fig. 68

3. Remove the burner (H) and clean components.
Do not use a wire brush.

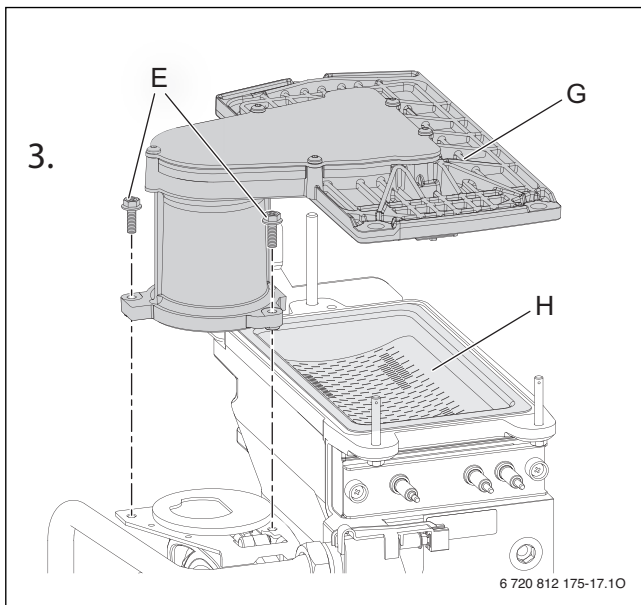
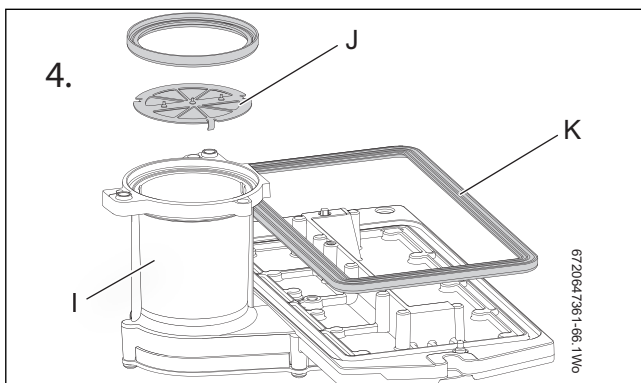

Fig. 69

6.1.6 To Check the Diaphragm in Burner Cover

4. Carefully withdraw diaphragm (J) from fan intake tube and check for soiling and splits.
- ▶ Carefully refit diaphragm (J) the correct way round into the fan intake tube.
 - ▶ Re-assemble the burner in the reverse order using a new seal (K).
 - ▶ Adjust air/gas ratio. Refer to section 6.2 “Setting the air/gas ratio”.



6.1.7 To Clean the Siphon/Condensate Trap

1. Pull condensate hose out of the trap.
 2. Remove trap from boiler.
- ▶ Clean the trap and check that the connection to the heat exchanger is clear.
 - ▶ Fill the condensate trap with approximately 250 millilitres of water and refit in reverse order.

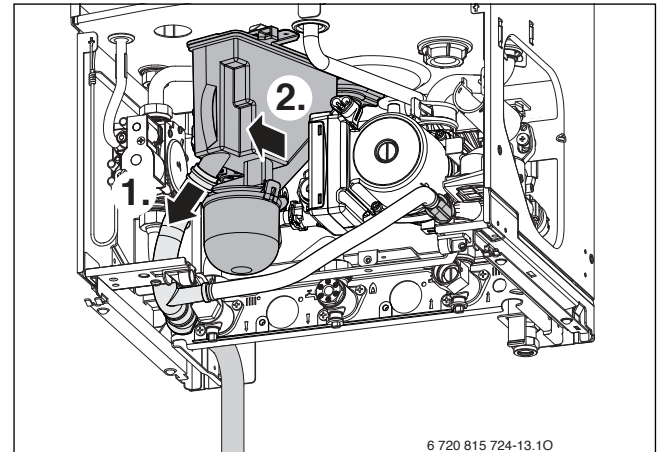

Fig. 70 Siphon removal

6.2 Setting the air/gas ratio

NOTICE: Air/Gas ratio

- ▶ The setting of the gas ratio must be carried out by a competent person. Setting the air/gas ratio must not be attempted unless the person carrying out the operation is equipped with a combustion analyser conforming to BS 7927 and is competent in its use.

Setting the CO₂

i When fitted with the optional diverter valve (not supplied) and running in performance test mode, the boiler will only operate the central heating circuits. If fitted to an S or Y plan system, the system must only be run in central heating mode. This is to allow sufficient time for this part of the commissioning procedure.

1. Connect manometer to inlet test point on the gas valve.
 - ▶ To adjust the CO₂ it will be necessary to first operate the boiler at maximum output.
 - ▶ Press and hold down the performance test button for 10 seconds until illuminated.
2. Turn central heating control to maximum; the boiler will then go to maximum output.

i The control will resume normal operation after 15 minutes or if the performance test button is pressed for over a second.

3. Using a flat blade screwdriver set the CO₂ via the max adjuster referring to the table below.

i CO₂ should be measured 10 minutes after firing the appliance.

Gas type	CO ₂ setting maximum	CO ₂ setting minimum
30CDI Classic System ^{ErP}		
Natural gas	9.6% ±0.4	9.0% ±0.4
LPG	11.5% ±0.4	10.5% ±0.4
35CDI Classic System ^{ErP}		
Natural gas	9.6% ±0.4	9.0% ±0.4
LPG	11.5% ±0.4	10.5% ±0.4

NOTE:
When checking an existing appliance the tolerance is ± 0.4%.
If checking after cleaning or component replacement or for adjustment when the reading is outside the tolerance given above, then the tolerance is ± 0.2%

CO - less than 200 ppm (0.002 ratio)

Table 33

- ▶ Measure the gas inlet pressure at the gas valve test point; it should be a maximum of 2.5mbar less than the pressure at the meter for natural gas and a maximum of 4mbar less than the pressure at the regulator for LPG.
- 4. Set the central heating control to minimum. This will make the boiler go to minimum power.
- 5. Measure the CO₂; it should now be at the figure for minimum output.
 - ▶ If not, use a 4mm Allen key to adjust the min adjustment on the gas valve until correct.
 - ▶ Return to maximum and re-check the CO₂.
 - ▶ If correct press and hold down the performance test button for two seconds; the button will cease to be illuminated and the blue power indicator will be permanently illuminated.
- ▶ Remove manometer and re-seal inlet pressure point on gas valve.
- ▶ Refit anti tamper cover onto the max adjuster.
- ▶ Replace the brass screw over the min adjuster on the valve.
- ▶ Re-assemble and refit boiler case.

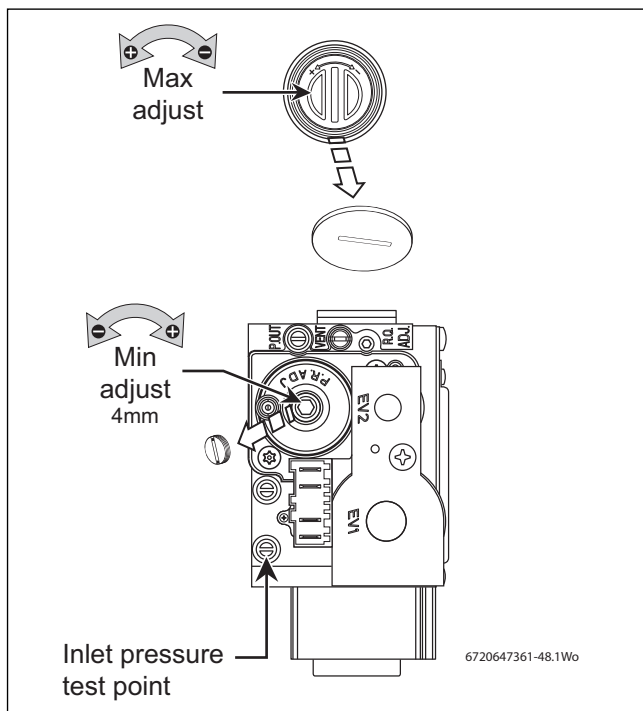

Fig. 71 Setting the Air/Gas ratio

6.3 Replacement of parts

CAUTION: TURN OFF THE GAS SUPPLY AND ISOLATE THE MAINS SUPPLIES BEFORE STARTING ANY WORK AND OBSERVE ALL RELEVANT SAFETY PRECAUTIONS.

NOTICE: After replacement of any components always check for gas tightness where relevant and carry out functional checks as described in the commissioning section. Replace any O-rings or gaskets.

Removing outer case

1. Remove bottom panel by pulling it forward and off.
2. Loosen but do not remove the 2 screws (A) securing boiler casing at the bottom of the appliance.
3. Pull upwards to release the clip (B) on top of the boiler.
4. Pull case forward and remove.

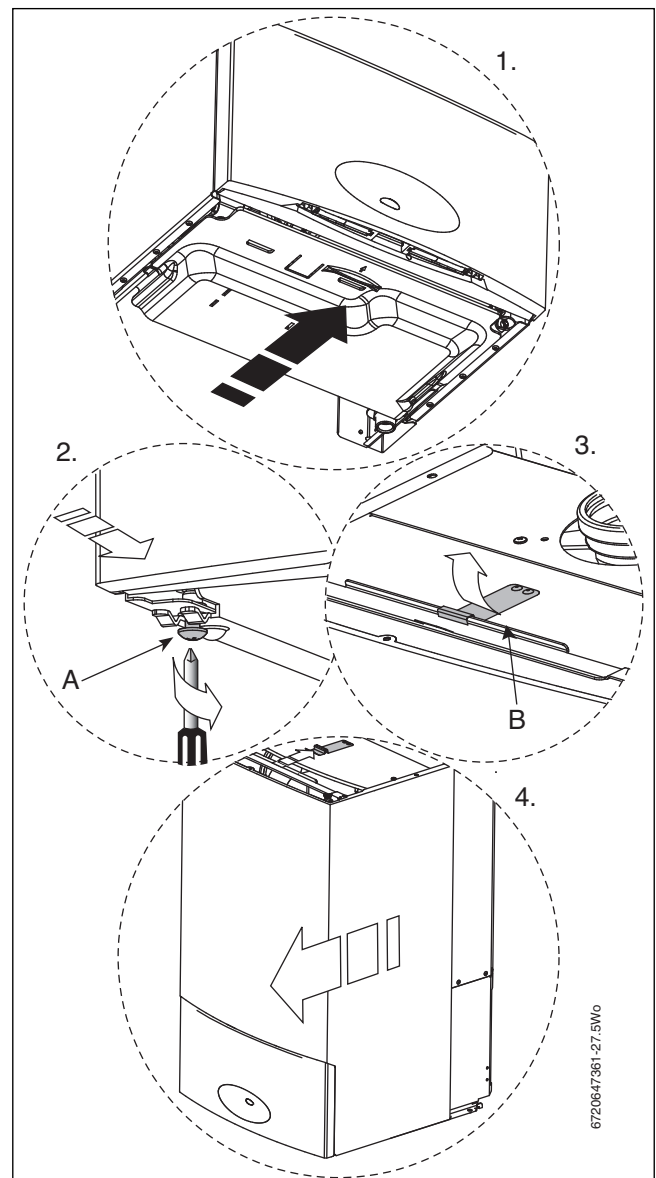

Fig. 72 Removing outer case

Moving boiler control to service position

1. Press in the centre of the white plastic clip securing the control panel and slide down to release.
2. Pull the control panel forward into the service position.

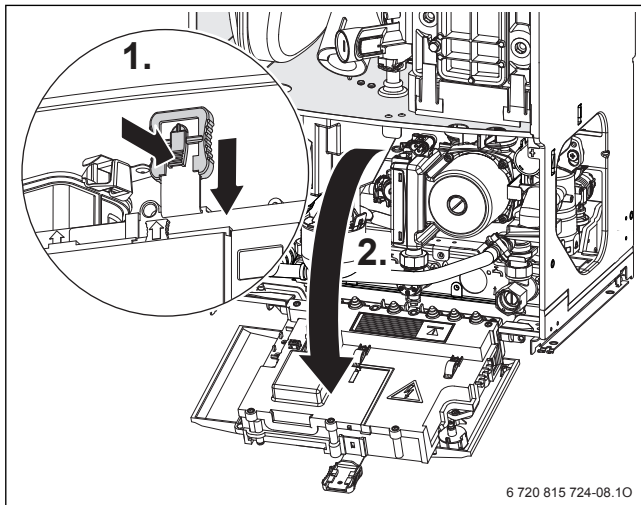

Fig. 73 Service position

3. Primary sensor

- ▶ Press retaining clip on plastic moulding and pull upwards until clear of pocket in heat exchanger.
- ▶ Separate sensor from connector, coat new sensor with heat conductive paste and replace.

4. Overheat thermostat

- ▶ Remove two electrical connectors from thermostat.
- ▶ Unscrew the sensor.

5. Flue limit thermostat

- ▶ Remove electrical connections.
- ▶ Push the flue limit thermostat into the sump.
- ▶ Retrieve the thermostat from the sump well.

6. Expansion Vessel

- ▶ Drain the appliance.

6.1 Remove locking screw (D).

6.2 Undo the union connection (E) at the bottom of the expansion vessel.

- ▶ Remove expansion vessel from boiler.

- ▶ Set the pressure of the new vessel to that required by the system.

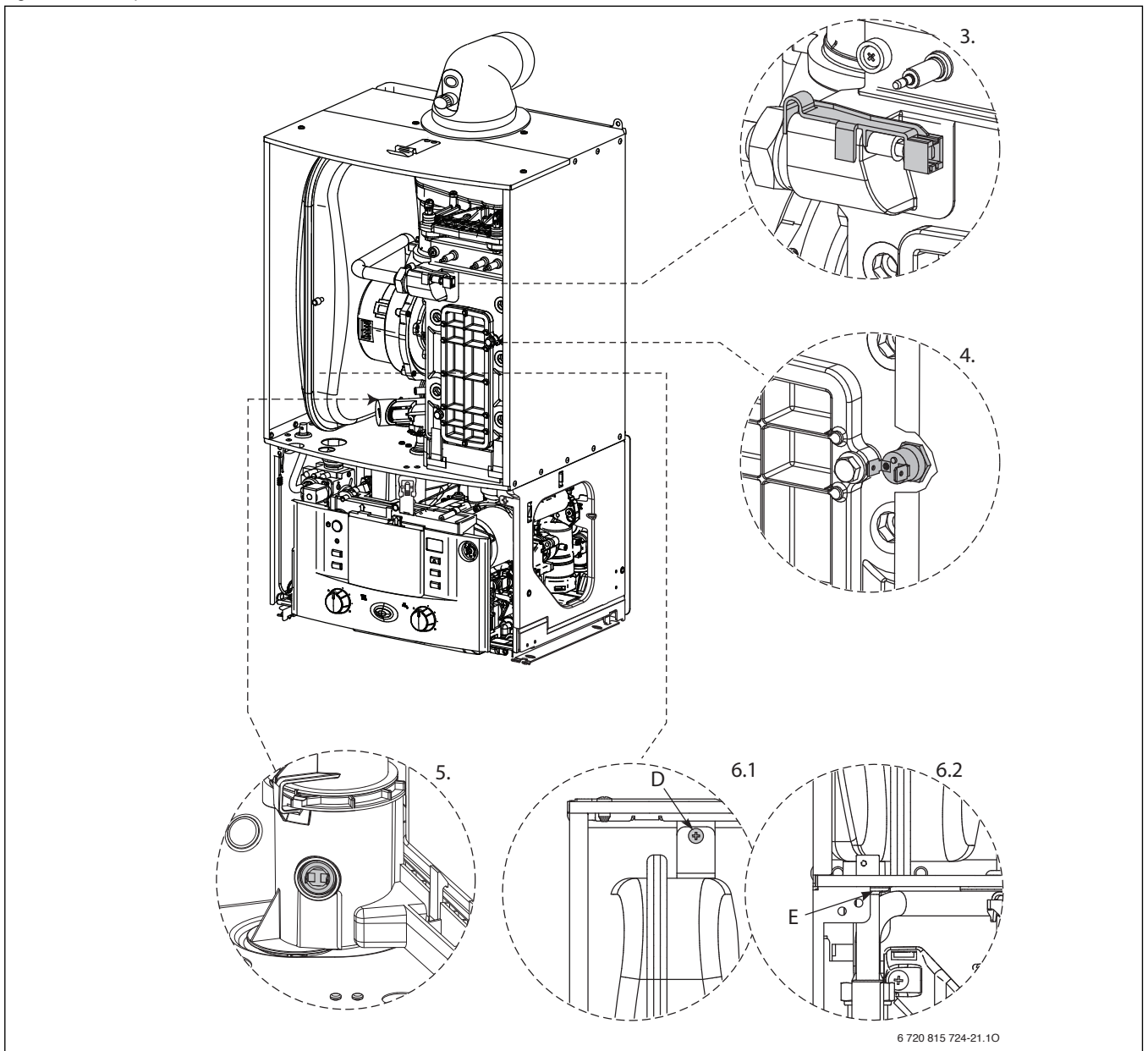

Fig. 74 Replacing parts

7. Gas valve

- ▶ Isolate gas supply at boiler gas cock.
- ▶ Pull out air inlet tube (A).
- ▶ Undo top gas connection (B) to gas valve.
- ▶ Undo bottom gas connection (C) to gas valve.
- ▶ Undo two securing screws (D) on the underside of casing.
- ▶ Pull valve up and forward out of boiler.
- ▶ Disconnect electrical connections.
- ▶ Replace valve with new seals and check for gas soundness.



The valve will require setting, follow procedure "Setting the gas/air ratio" in the gas conversion section.

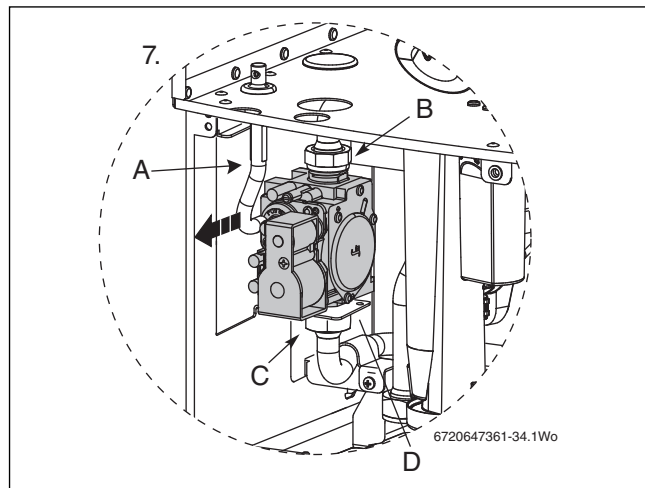

Fig. 75 Gas valve removal

8. Siphon/condensation trap

1. Pull condensate hose out of the trap.
 2. Remove trap from boiler.
- ▶ Clean trap and check that the connection to the heat exchanger is clear.
 - ▶ Fill the condensate trap with approximately 1/4 litre of water and refit in reverse order.

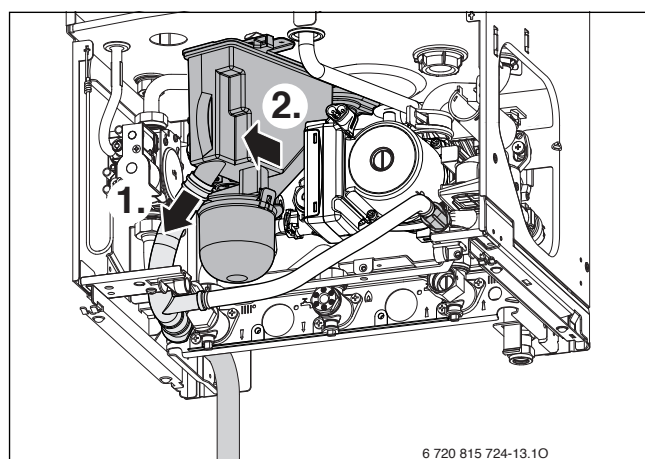

Fig. 76 Siphon removal

9. Access to boiler control components

- ▶ Remove 3 screws (A) and remove cover from control.

10. PCB fuse

- ▶ Remove fuse (B) from the PCB and replace.
- ▶ There is a spare fuse clipped into the cover.

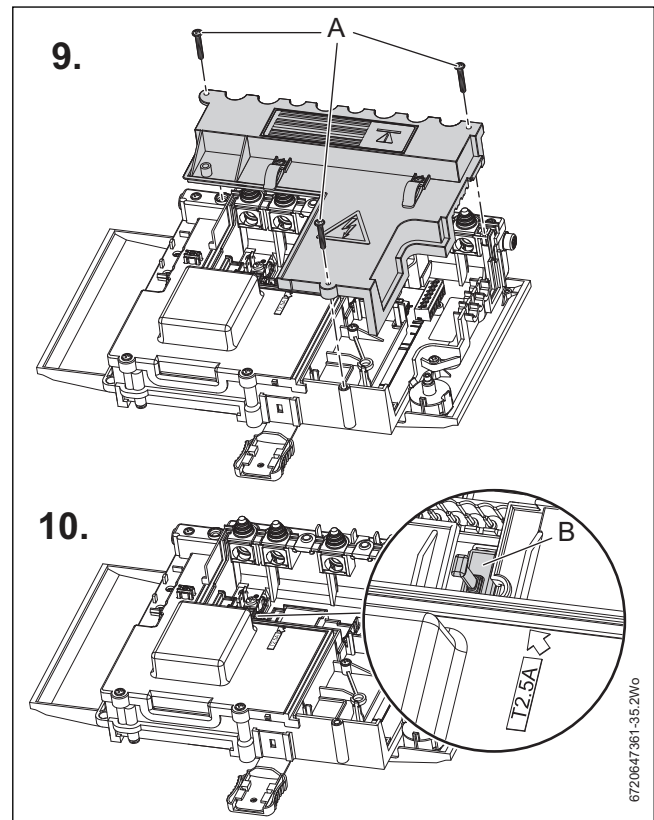

Fig. 77 Component and fuse access

11. PCB removal

To gain access to the PCB:

- ▶ Remove the five screws shown in the diagram below and remove the PCB cover.

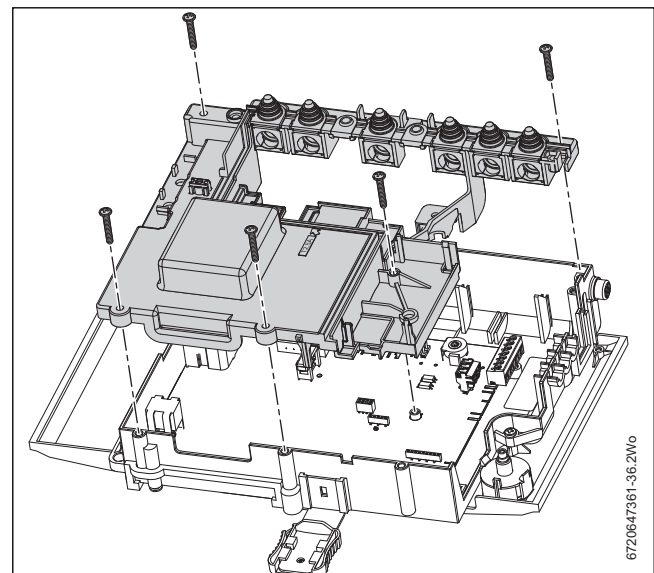

Fig. 78 PCB access

12. Fan assembly



NOTICE: Air/Gas ratio

- ▶ After re-assembly the combustion must be checked using the procedure in the section "Setting the air/gas ratio."
- ▶ The setting of the gas ratio must be carried out by a competent person.
Setting the air/gas ratio must not be attempted unless the person carrying out the conversion is equipped with a combustion analyser conforming to BS 7927 and is competent in its use.

- ▶ Remove electrical connector from fan.
 - ▶ Remove the siphon/condensate trap.
1. Undo the union connection (A) from the top of the gas valve.
- ▶ Remove wire clip (B) from air/gas adjustment assembly (C) then pull gas pipe down.
2. Unscrew two screws (D).
 3. Remove fan from boiler.
 4. Remove three screws retaining the air/gas adjustment assembly (E).
- ▶ Reassemble with new fan assuring that seals are correctly fitted.

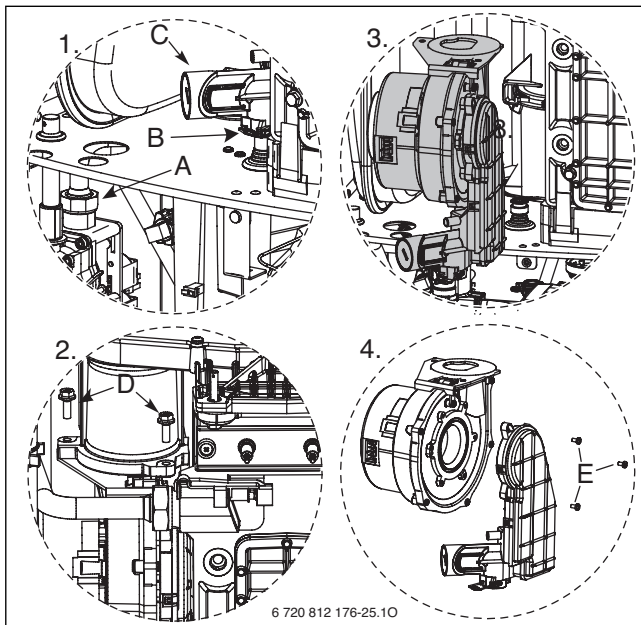

Fig. 79 Fan assembly removal

13. Electrode assembly



WARNING: Electrode gasket

- ▶ Do not remove the electrode assembly unless a new gasket is available for re-assembly.

- ▶ Disconnect spark electrodes and flame sensor connection.
- ▶ Remove two screws (F).
- ▶ Remove spark/flame electrode assembly (G) from heat exchanger.
- ▶ Inspect the spark/flame electrode assembly and ceramics for signs of contamination or damage, replace as necessary.
- ▶ If necessary, clean the spark/flame electrode assembly with a plastic scouring pad.
- ▶ Replace electrode gasket.
- ▶ Re-assemble with the new gasket and secure with the screws (F) removed earlier.

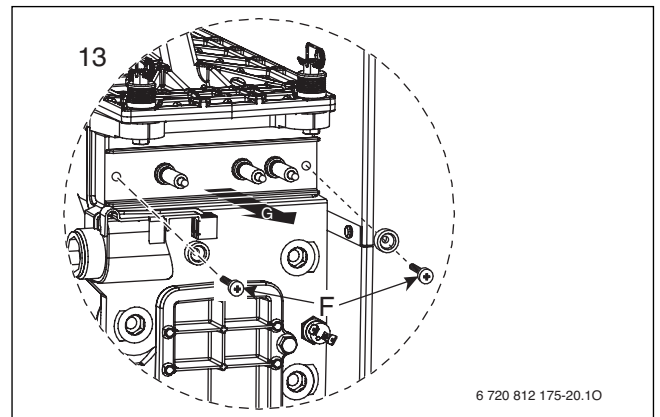

Fig. 80 Electrode assembly

14. Air/gas manifold



WARNING: Air/Gas manifold

- ▶ Do not remove the manifold unless a new gasket is available for re-assembly.

1. Remove cover panel (A) by removing screws (B).
- ▶ Check that the boiler is completely isolated from the gas supply.

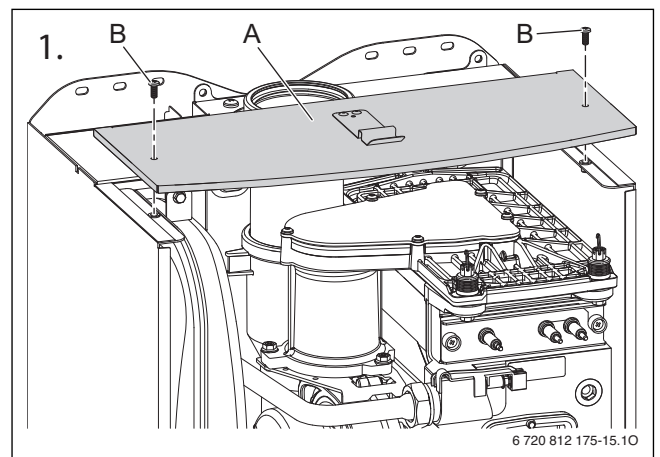

Fig. 81 Top panel

2. Remove clips (C) and unscrew the two bolts (D).
- ▶ Unscrew and remove the two hexagon screws (E) securing the fan.
 - ▶ Slacken fully the rear securing bolt (F).

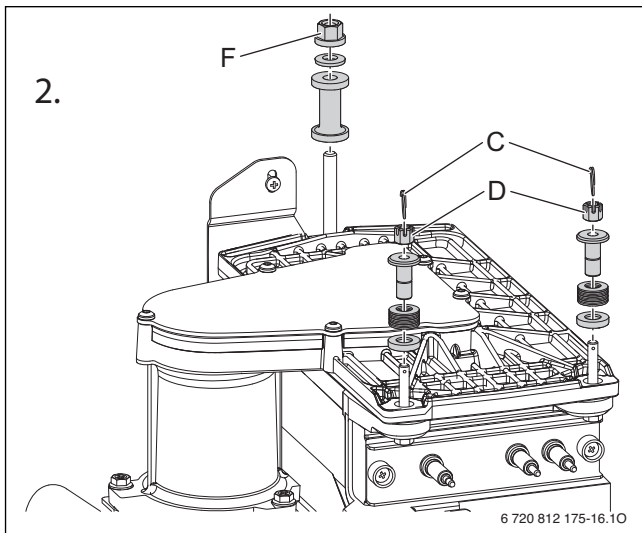

Fig. 82 Release air/gas manifold

3. Remove air/gas manifold (I)

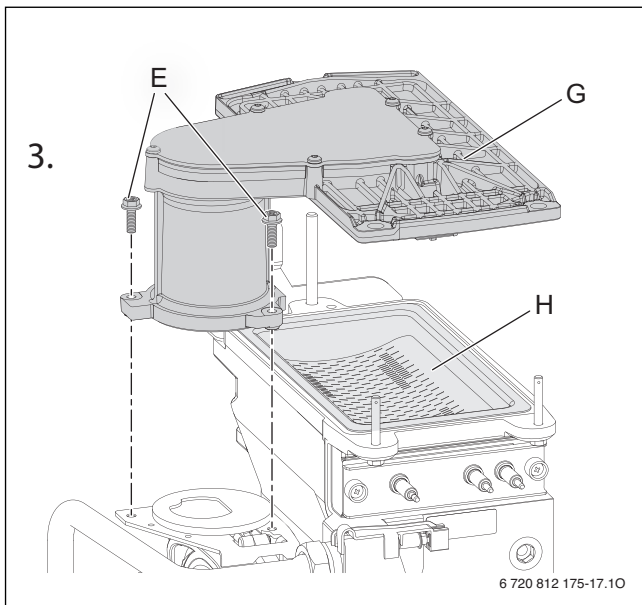

Fig. 83 Air/gas manifold

4. Open air/gas manifold (I).

- ▶ Carefully withdraw diaphragm (J) from fan intake tube and check for soiling and splits.

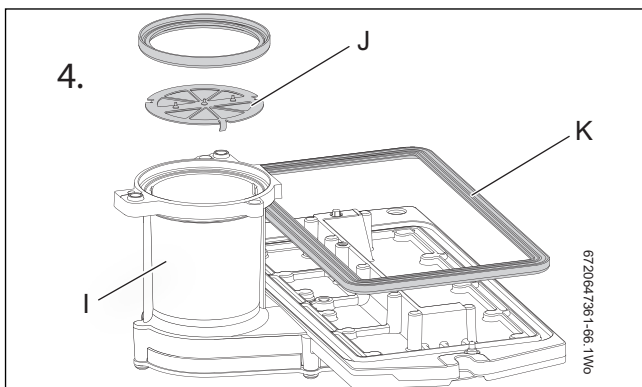

Fig. 84 Diaphragm

15. Burner

- ▶ Remove the burner (H).
- ▶ Replace new burner in correct position.
- ▶ Ensure that a new seal (K) is used, refer to fig. 84.

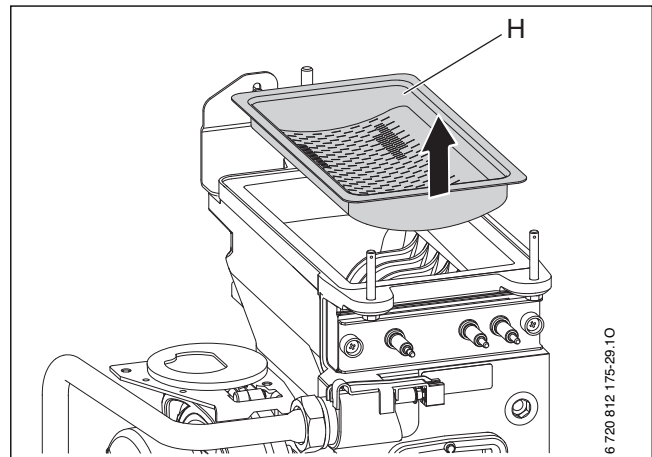

Fig. 85 Burner removal

16. Heat exchanger

- ▶ Isolate flow and return valves and drain the boiler.
- ▶ Remove condensate trap (see page 44).
- ▶ Remove fan assembly (see page 45).

1. Remove plastic nut (A) from the base of the inner casing

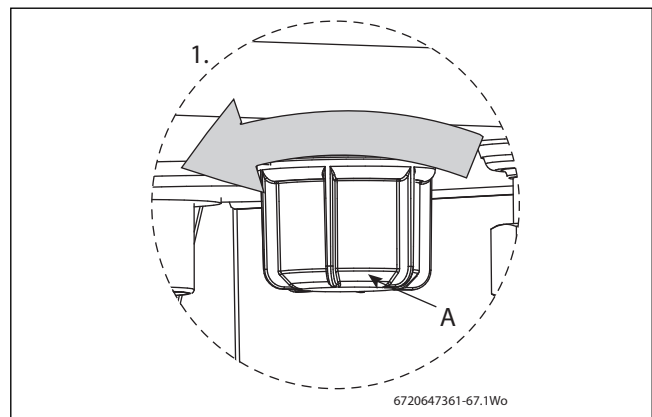

Fig. 86 Heat exchanger removal 1

2. Remove return pipe at the bottom of heat exchanger.

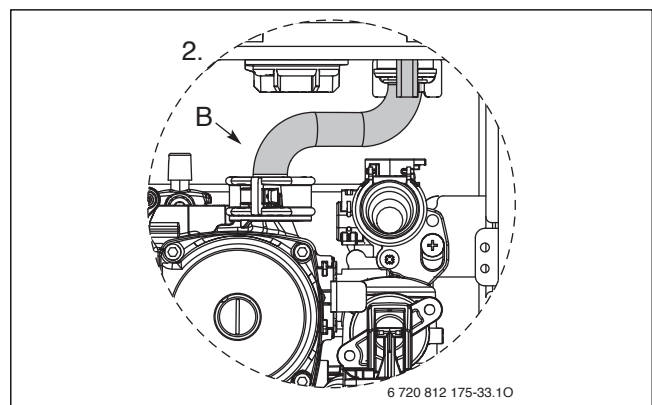

Fig. 87 Heat exchanger removal 2

3. Remove screw at the top of the heat exchanger (C).

- ▶ Unscrew the flow pipe (D).

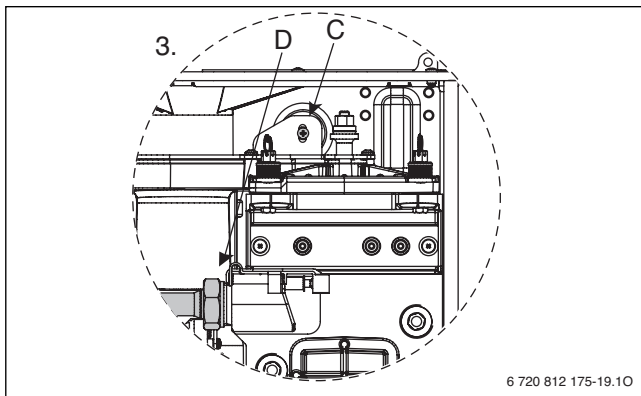

Fig. 88 Heat exchanger removal 3

4. Undo flue connection (E) from sump (F).

- ▶ Pull flue pipe up.
- ▶ Remove the heat exchanger.

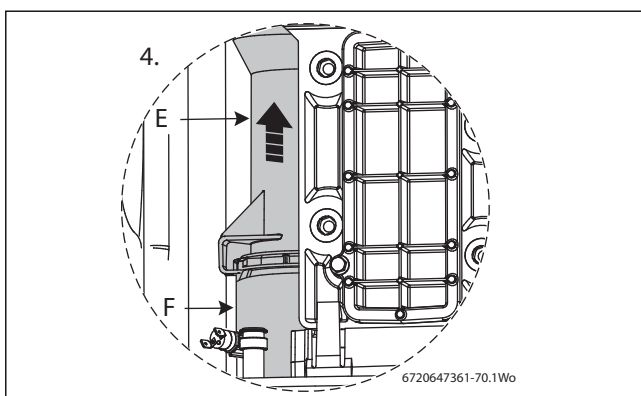

Fig. 89 Heat exchanger removal 4

17. Diverter valve motor (if fitted)

There is no need to drain the appliance.

- ▶ Disconnect the electrical connector from the diverter valve motor.

1. Pull the motor assembly (A) towards you.
The assembly will slide free from the valve.

- ▶ To refit, follow the above in reverse.



In case of problems when refitting the motor: Connect the electrical connector to the motor and switch the appliance on. Then the motor goes to the middle position and you can refit it without difficulty.

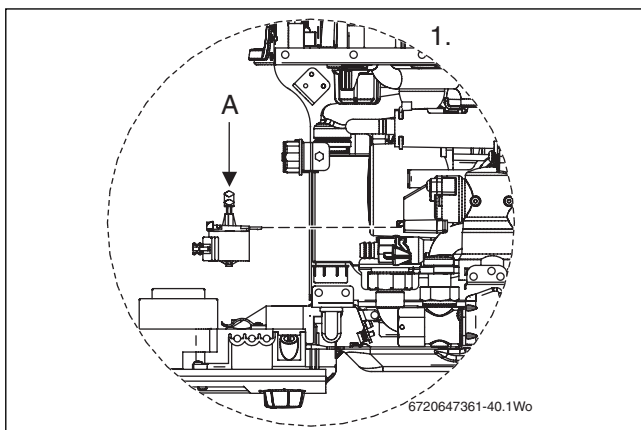

Fig. 90 Diverter valve motor removal

18. Diverter valve

- ▶ Ensure the appliance has been fully drained.
- ▶ Disconnect the electrical connector from the diverter valve motor.
- ▶ Undo the two screws holding the valve to the plastic housing.

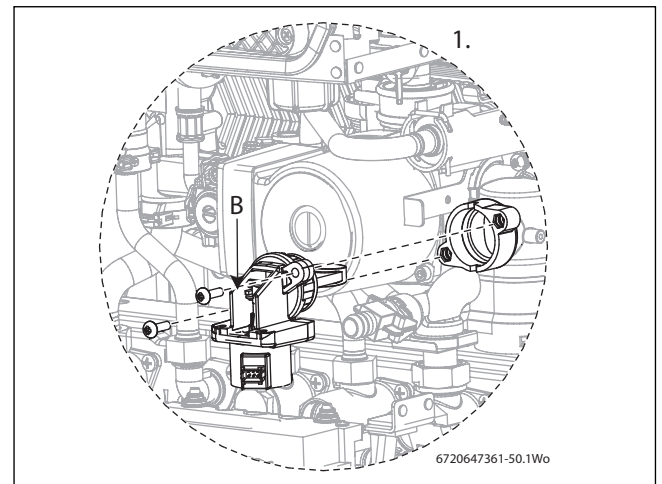

Fig. 91 Diverter valve removal

1. Withdraw the valve (B) and clean the valve chamber if necessary.

- ▶ To refit, follow the above in reverse.
Ensure any seals that have been disturbed are renewed.

19. Auto air vent

- ▶ Ensure the appliance has been fully drained.

1. Use a screwdriver or similar to rotate the air vent anticlockwise.

2. Lift the air vent (C) out of the housing and remove.

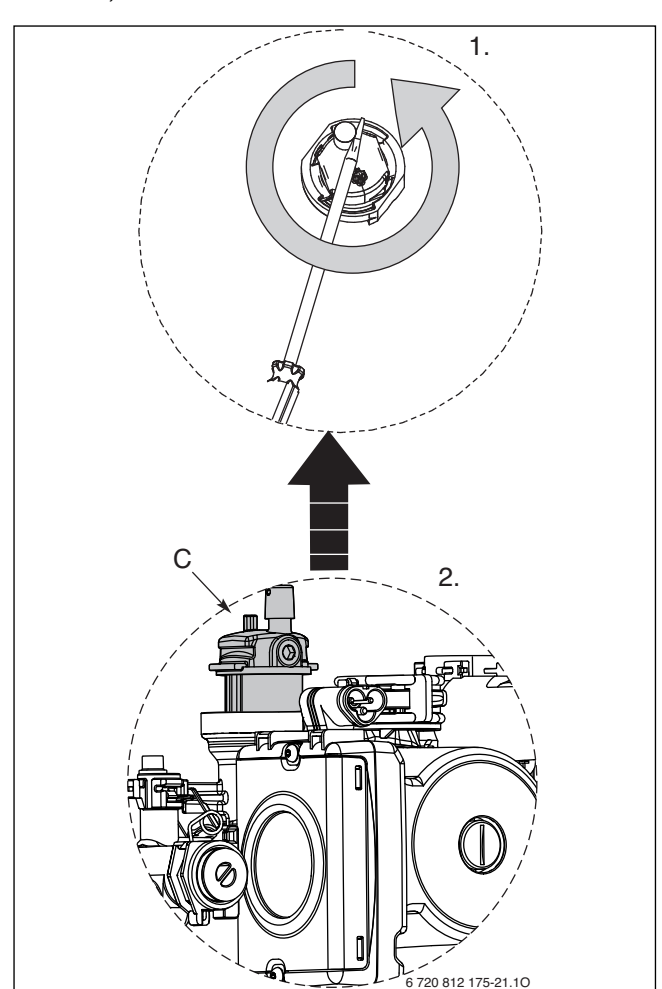

Fig. 92 Auto Air Vent removal

21. Pump head

- ▶ Ensure the appliance has been fully drained.
- 1. Disconnect the electrical connections from the pump following steps:
 - i. [Diagram: Removing electrical connection]
 - ii. [Diagram: Removing electrical connection]
 - iii. [Diagram: Removing electrical connection]
 - iv. [Diagram: Removing electrical connection]
- 2. Remove the four Allen bolts (A) securing the pump at each corner.
- 3. Gently pull the pump towards you and remove.
- ▶ To refit, follow the above in reverse.

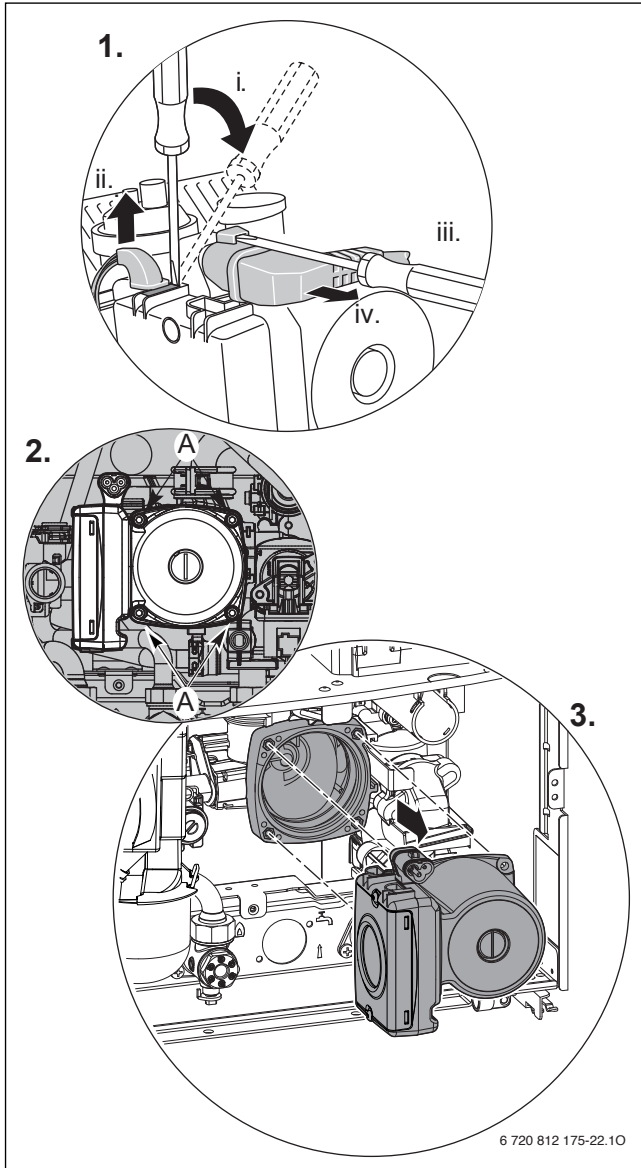

Fig. 93

22. Pressure gauge

- ▶ Ensure the appliance has been fully drained.
- ▶ Withdraw the spring clip from the pressure sensing head housing.
- ▶ Undo the nut on the rear of the pressure gauge.
- ▶ Remove the pressure sensing head and pressure gauge capillary from the housing.
- ▶ To refit, follow the above in reverse.

DO NOT leave out the washer from the capillary when fitting a replacement gauge.

25. Drain tap

- ▶ Ensure the appliance has been fully drained.
- 1. Withdraw the drain pipe from the drain tap. To do this, remove retaining spring from the drain pipe.
- 2. Rotate the drain tap fully anticlockwise.
- 3. Withdraw the drain tap from its housing.
- ▶ To refit, follow the above in reverse. Ensure any seals that have been disturbed are renewed.

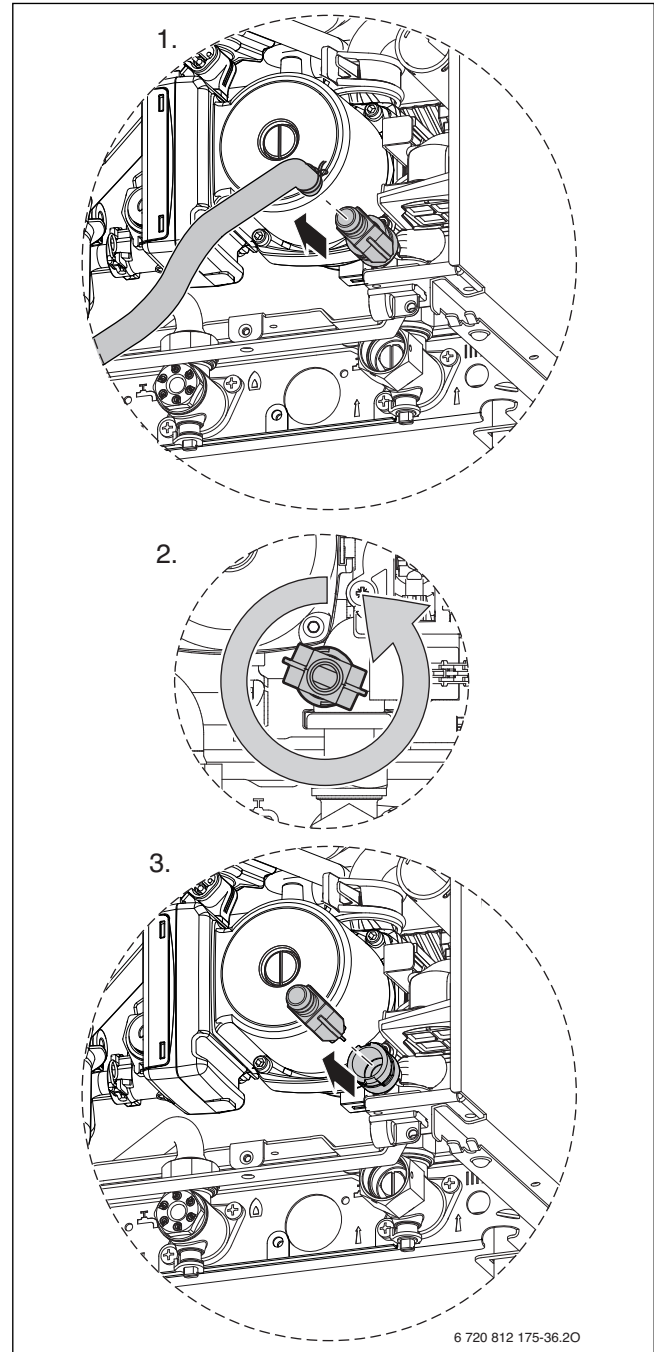

Fig. 94 Drain tap removal

26. Hydraulic block

- ▶ Ensure the appliance has been fully drained.
 - ▶ Disconnect the electrical connections to the NTC, Turbine and pump.
 - ▶ Undo the nuts securing the copper water pipes to the manifold (there is no need to remove the gas pipe).
 - ▶ Disconnect drain pipe from drain tap (see e. g. step 1 in Fig. 94).
 - ▶ Release the spring clips securing these water pipes to the plastic housing and remove the pipes.
1. Release the spring clip securing the expansion vessel pipe to the plastic housing and remove the pipe.
 2. Undo the nut securing the pressure gauge to its bracket and remove the gauge.
 3. Release the locking devices that secure the two copper water pipes leading to the combustion chamber by squeezing the two tabs together and rotating anticlockwise (viewed from above).
 4. Undo the two screws securing the hydraulic block to the chassis (located top left/top right of the housing).
 5. Lift the left hand side of the block slightly.
 6. Manoeuvre the block out, starting with the right hand side.
 7. Pull the hydraulic block completely out of the boiler.
- ▶ Take care not to snag the harness or pressure gauge bracket.



The block will still contain a small amount of water, which will spill if the block is tilted.

- ▶ To refit, follow the above in reverse. Ensure any seals that have been disturbed are renewed.

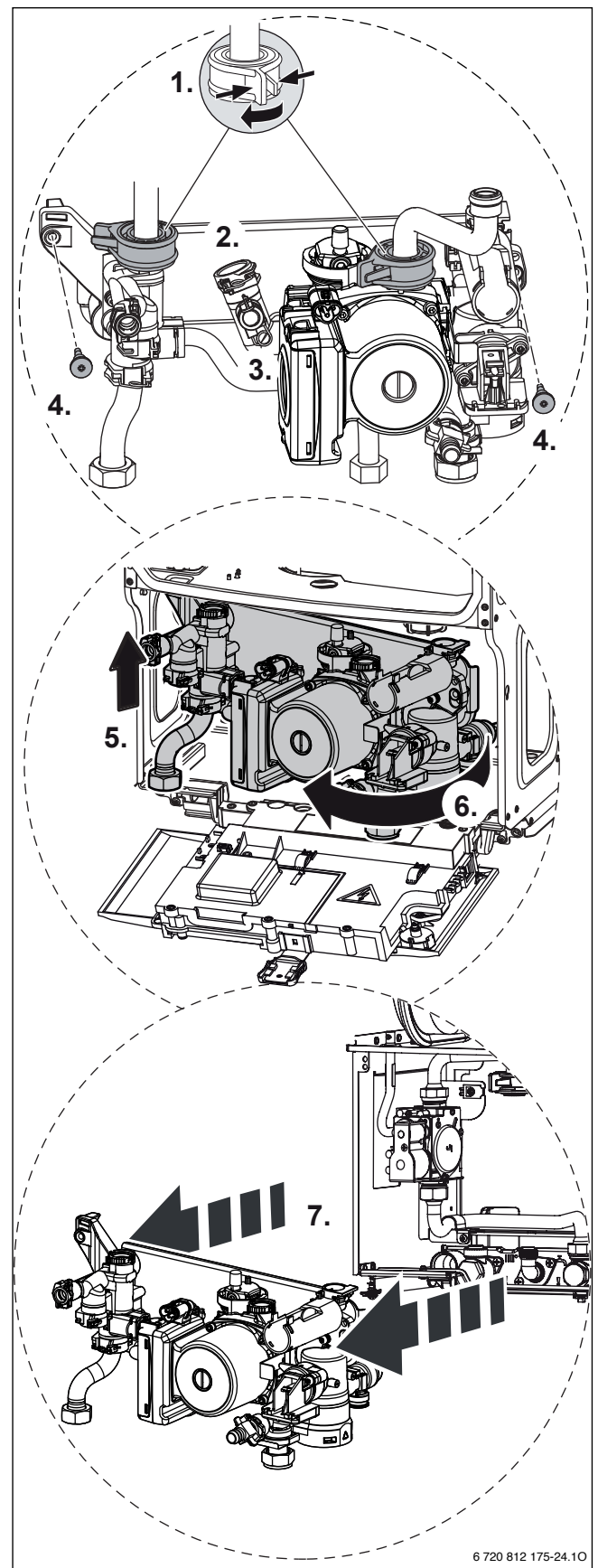

Fig. 95

6 720 812 175-24.10

27. ch pressure relief valve

- ▶ Remove the Hydraulic block from the boiler
(→ 26. Hydraulic block).
1. Remove the spring clip from the Pressure relief valve housing.
 2. Withdraw the pressure release valve (A) from its housing.
- ▶ To refit, follow the above in reverse.
 - ▶ Ensure any seals that have been disturbed are renewed.

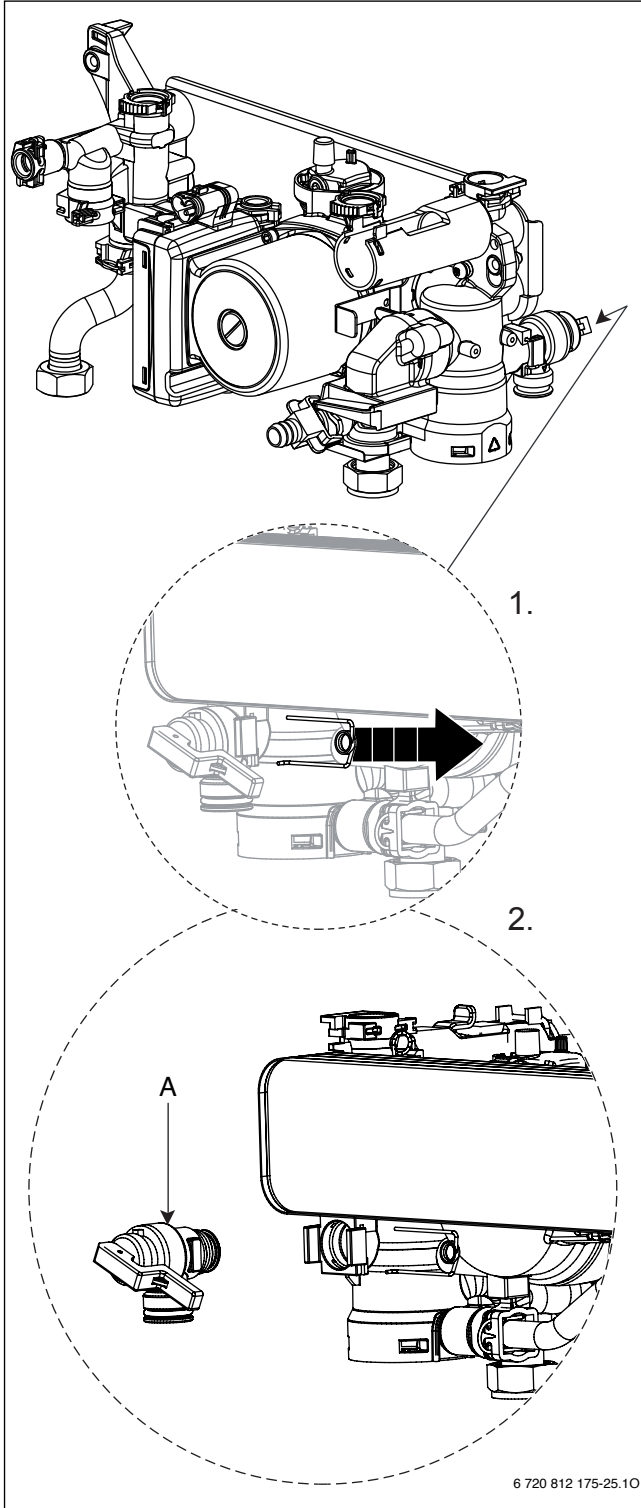

Fig. 96

6.4 Short parts list







	Fan 8 717 204 453 0 GC No. H26 536		Burner 8 718 006 658 0 GC No. E27 200		Burner skin seal 8 711 004 168 0 GC No. E27 201
	Gas valve WHS 8 718 221 347 0 GC No. TO BE CONFIRMED		Temperature limit sensor 8 722 963 858 0 GC No. H08 291		Electrodes 8 716 771 932 0 GC No. H22 458
	Pump assembly 8 718 221 728 0 GC No. H22 463		Pressure gauge 8 717 208 107 0 GC No. H02 528		Diverter valve assembly 8 716 106 845 0 GC No. H02 533
	Diverter valve motor 8 716 106 847 0 GC No. H02 534		Control sensor - primary 8 714 500 087 0 GC No. E74 536		Flue sample plug air intake 8 716 111 253 0
	Flue overheat thermostat 8 710 506 267 0		Auto Air Vent 8 716 106 445 0		Flue sample plug 8 716 111 252 0
	Control unit 8 737 703 196 0		Bearing plate (Fan intake diaphragm) 8 715 505 883 0		Flue sample plug Vertical flue
	Drain tap 8 716 771 932 0				

Table 34 Parts list

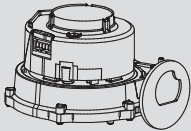
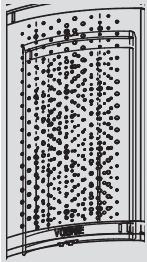
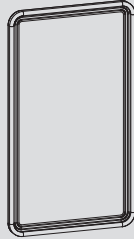
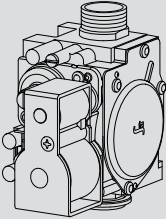
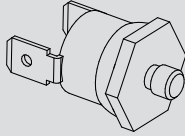
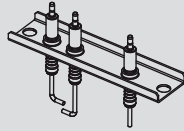
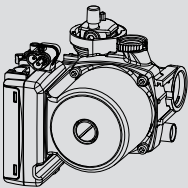
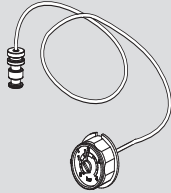
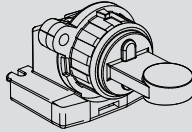
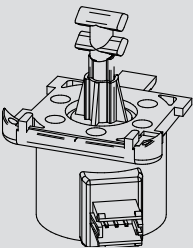
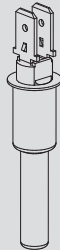
7 FAULT FINDING & DIAGNOSIS

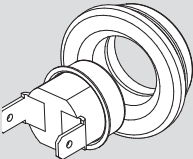
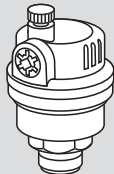
7.1 Fault finding

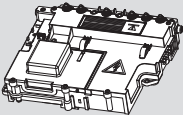
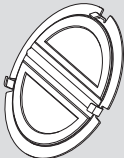

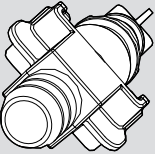
This fault finding information is for guidance only. The Worcester, Bosch Group cannot be held responsible for costs incurred by persons not deemed to be competent.

The electronic control system for this boiler incorporates a blue central indicator. This normally confirms the permanent mains supply but, by flashing during a fault, provides a guide to the cause as listed.

This fault finding system assumes that the appliance has been operating normally until the time of failure (i.e. not a first installation error).

PRELIMINARY CHECKS: Preliminary electrical system checks are the first electrical checks to be carried out during a fault-finding procedure. On completion of the Service/Fault-Finding task which has required the breaking and remaking of electrical connections, check:

- (a) EARTH CONTINUITY
- (b) SHORT CIRCUIT CHECK
- (c) POLARITY
- (d) RESISTANCE TO EARTH

An optional text display is available which gives a text description of the service functions of the boiler.

Display code	Description	Remedy
A7	Hot water NTC sensor defective.	Check hot water NTC sensor and connecting lead for circuit breaks/short circuits.
A8	Break in communication to FX/Sense controls.	Check electrical connections.
b1	Code plug not detected.	Insert code plug correctly, test and replace if necessary.
C6	Fan speed too low.	Check fan lead and connector, and fan; replace as necessary.
E2	CH flow NTC sensor defective.	Check CH flow NTC sensor and connecting lead.
E9	Safety temp. limiter in CH flow has tripped.	Check system pressure, check safety temp. limiters, check pump operation, check fuse on pcb, bleed appliance.
EA	Flame not detected/Ignition lockout.	Is gas cock turned on? Check gas supply pressure, power supply, igniter electrode and lead, ionisation sensing electrode and lead and CO2 level. Check the condition of the flue, is it blocked? Check the condensate pipe, is it blocked or frozen?
F0	Internal error.	Check electrical connector contacts, programmer inter-face module ignition leads are not loose; replace pcb if necessary.
F7	Flame detected even though appliance switched off.	Check electrode assembly, dry pcb. Flue clear?
FA	Flame detected after gas shut off.	Check gas valve and wiring to gas valve. Clean condensation trap and check electrode assembly. Flue clear?
Fd	Reset button pressed by mistake	Press reset button again

Table 35

A more detailed fault finding procedure is described in the Service Engineer's booklet..

7.2 Central heating function

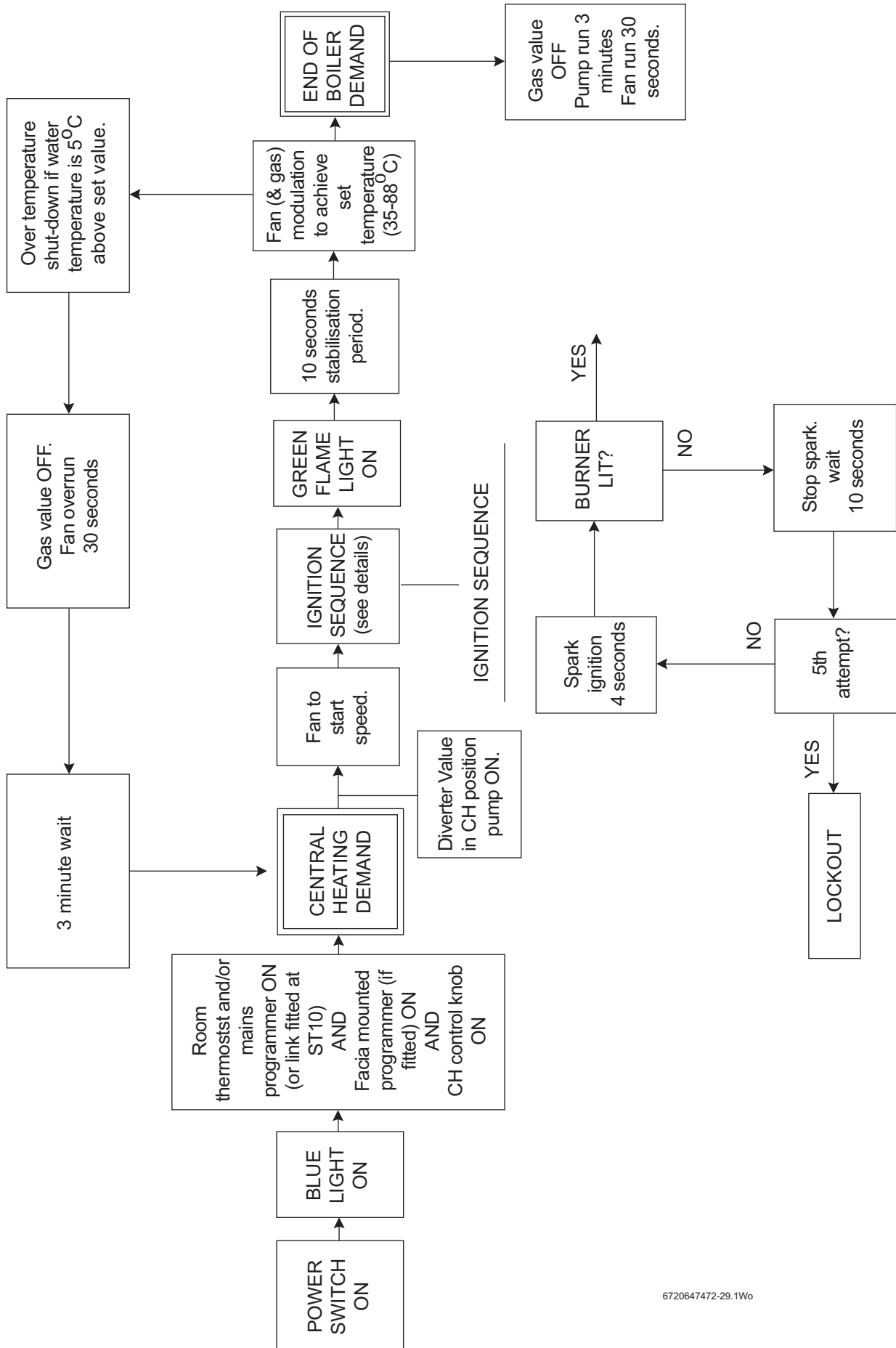

6720647472-29.1W0

7.3 Cylinder heat function



The cylinder heat function is available only with the optional diverter valve fitted.

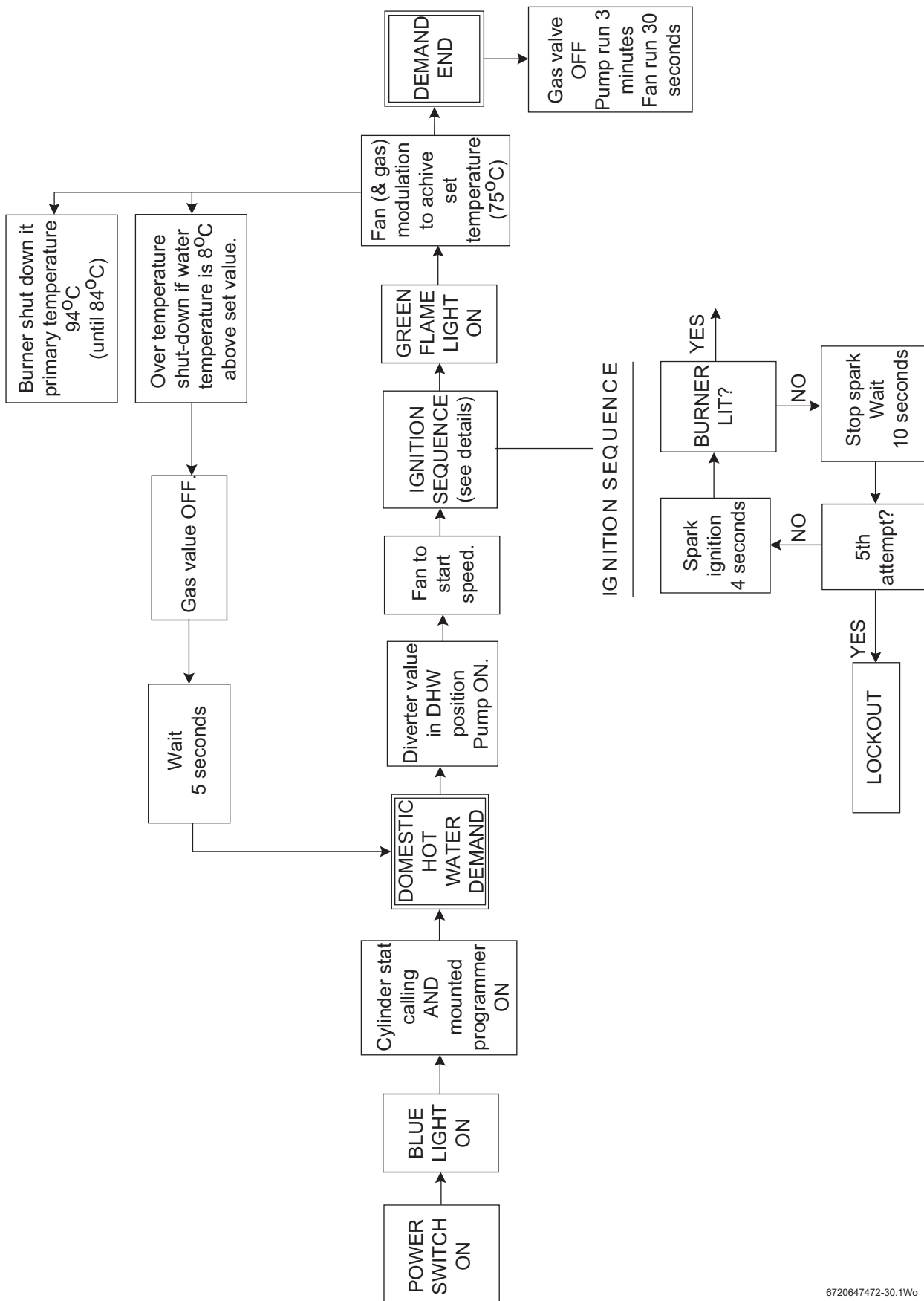

6720647472-30.1Wo

7.4 Protection function

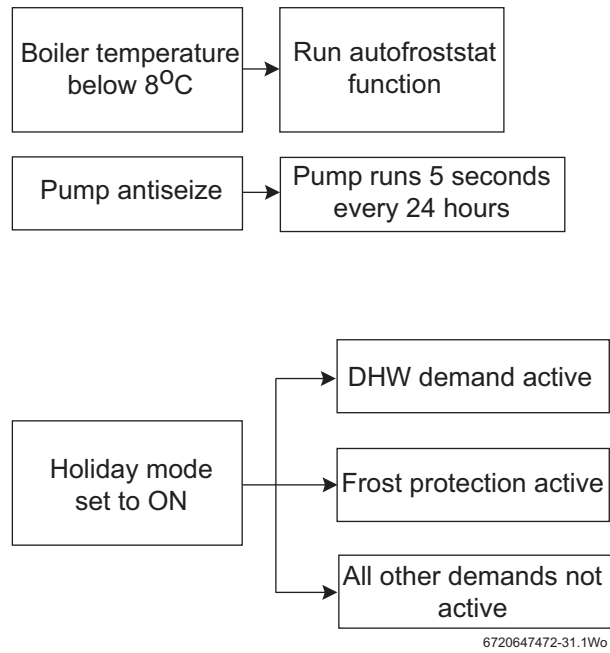

Notes

Notes

SERVICE RECORD

It is recommended that your heating system is serviced regularly and that the appropriate Service Interval Record is completed.

Service Provider

Before completing the appropriate Service Record below, please ensure you have carried out the service as described in the manufacturer's instructions. Always use the manufacturer's specified spare part when replacing controls.

SERVICE 01					Date:
Engineer name:					
Company name:					
Telephone No:					
Gas safe register No:					
Record:	At max. rate:	CO	ppm	AND	CO ₂ %
	At min. rate: (Where Possible)	CO	ppm	AND	CO ₂ %
Comments:					
Signature					

SERVICE 02					Date:
Engineer name:					
Company name:					
Telephone No:					
Gas safe register No:					
Record:	At max. rate:	CO	ppm	AND	CO ₂ %
	At min. rate: (Where Possible)	CO	ppm	AND	CO ₂ %
Comments:					
Signature					

SERVICE 03					Date:
Engineer name:					
Company name:					
Telephone No:					
Gas safe register No:					
Record:	At max. rate:	CO	ppm	AND	CO ₂ %
	At min. rate: (Where Possible)	CO	ppm	AND	CO ₂ %
Comments:					
Signature					

SERVICE 04					Date:
Engineer name:					
Company name:					
Telephone No:					
Gas safe register No:					
Record:	At max. rate:	CO	ppm	AND	CO ₂ %
	At min. rate: (Where Possible)	CO	ppm	AND	CO ₂ %
Comments:					
Signature					

SERVICE 05					Date:
Engineer name:					
Company name:					
Telephone No:					
Gas safe register No:					
Record:	At max. rate:	CO	ppm	AND	CO ₂ %
	At min. rate: (Where Possible)	CO	ppm	AND	CO ₂ %
Comments:					
Signature					

SERVICE 06					Date:
Engineer name:					
Company name:					
Telephone No:					
Gas safe register No:					
Record:	At max. rate:	CO	ppm	AND	CO ₂ %
	At min. rate: (Where Possible)	CO	ppm	AND	CO ₂ %
Comments:					
Signature					

SERVICE 07					Date:
Engineer name:					
Company name:					
Telephone No:					
Gas safe register No:					
Record:	At max. rate:	CO	ppm	AND	CO ₂ %
	At min. rate: (Where Possible)	CO	ppm	AND	CO ₂ %
Comments:					
Signature					

SERVICE 08					Date:
Engineer name:					
Company name:					
Telephone No:					
Gas safe register No:					
Record:	At max. rate:	CO	ppm	AND	CO ₂ %
	At min. rate: (Where Possible)	CO	ppm	AND	CO ₂ %
Comments:					
Signature					

SERVICE 09					Date:
Engineer name:					
Company name:					
Telephone No:					
Gas safe register No:					
Record:	At max. rate:	CO	ppm	AND	CO ₂ %
	At min. rate: (Where Possible)	CO	ppm	AND	CO ₂ %
Comments:					
Signature					

SERVICE 10					Date:
Engineer name:					
Company name:					
Telephone No:					
Gas safe register No:					
Record:	At max. rate:	CO	ppm	AND	CO ₂ %
	At min. rate: (Where Possible)	CO	ppm	AND	CO ₂ %
Comments:					
Signature					

*All installations in England and Wales must be notified to Local Authority Building Control (LABC) either directly or through a Competent Persons Scheme. A Building Regulations Compliance Certificate will then be issued to the customer.



GAS BOILER SYSTEM COMMISSIONING CHECKLIST

This Commissioning Checklist is to be completed in full by the competent person who commissioned the boiler as a means of demonstrating compliance with the appropriate Building Regulations and then handed to the customer to keep for future reference.

Failure to install and commission according to the manufacturer's instructions and complete this Benchmark Commissioning Checklist will invalidate the warranty. This does not affect the customer's statutory rights.

Customer name:				Telephone number:			
Address:							
Boiler make and model:							
Boiler serial number:							
Commissioned by (PRINT NAME):				Gas Safe register number:			
Company name:				Telephone number:			
Company address:							
				Commissioning date:			
To be completed by the customer on receipt of a Building Regulations Compliance Certificate*							
Building Regulations Notification Number (if applicable):							
CONTROLS (tick the appropriate boxes)							
Time and temperature control to heating		Room thermostat and programmer/timer		Programmable room thermostat			
		Load/weather compensation		Optimum start control			
Time and temperature control to hot water		Cylinder thermostat and programmer/timer		Combination Boiler			
Heating zone valves		Fitted		Not required			
Hot water zone valves		Fitted		Not required			
Thermostatic radiator valves		Fitted		Not required			
Automatic bypass to system		Fitted		Not required			
Boiler interlock				Provided			
ALL SYSTEMS							
The system has been flushed and cleaned in accordance with BS7593 and boiler manufacturer's instructions						Yes	
What system cleaner was used?							
What inhibitor was used?						Quantity	
						litres	
Has a primary water system filter been installed?						Yes	
						No	
CENTRAL HEATING MODE measure and record:							
Gas rate		m ³ /hr		OR		ft ³ /hr	
Burner operating pressure (if applicable)		mbar		OR Gas inlet pressure		mbar	
Central heating flow temperature						°C	
Central heating return temperature						°C	
COMBINATION BOILERS ONLY							
Is the installation in a hard water area (above 200ppm)?						Yes	
						No	
If yes, and if required by the manufacturer, has a water scale reducer been fitted?						Yes	
						No	
What type of scale reducer has been fitted?							
DOMESTIC HOT WATER MODE Measure and Record:							
Gas rate		m ³ /hr		OR		ft ³ /hr	
Burner operating pressure (at maximum rate)		mbar		OR Gas inlet pressure at maximum rate		mbar	
Cold water inlet temperature						°C	
Hot water has been checked at all outlets						Yes	
						Temperature	
						°C	
Water flow rate						l/min	
CONDENSING BOILERS ONLY							
The condensate drain has been installed in accordance with the manufacturer's instructions and/or BS5546/BS6798						Yes	
ALL INSTALLATIONS							
Record the following:		At max. rate:		CO		ppm	
		AND		CO/CO ₂		Ratio	
		At min. rate: (where possible)		CO		ppm	
		AND		CO/CO ₂		Ratio	
The heating and hot water system complies with the appropriate Building Regulations						Yes	
The boiler and associated products have been installed and commissioned in accordance with the manufacturer's instructions						Yes	
The operation of the boiler and system controls have been demonstrated to and understood by the customer						Yes	
The manufacturer's literature, including Benchmark Checklist and Service Record, has been explained and left with the customer						Yes	
Commissioning Engineer's Signature							
Customer's Signature							
(To confirm satisfactory demonstration and receipt of manufacturer's literature)							

*All installations in England and Wales must be notified to Local Authority Building Control (LABC) either directly or through a Competent Persons Scheme. A Building Regulations Compliance Certificate will then be issued to the customer.



Worcester, Bosch Group
Cotswold Way, Warndon, Worcester WR4 9SW.
Tel. 0330 123 9559

Worcester, Bosch Group is a brand name of Bosch Thermotechnology Ltd.
worcester-bosch.co.uk

6 720 815 724

WORCESTER, BOSCH GROUP:

TECHNICAL SUPPORT: 0330 123 3366
APPOINTMENTS: 0330 123 9339
SPARES: 0330 123 9779
LITERATURE: 0330 123 9119
TRAINING: 0330 123 0166
SALES: 0330 123 9669

