

INSTALLATION, COMMISSIONING AND SERVICING INSTRUCTIONS

WALL HUNG RSF GAS FIRED CONDENSING SYSTEM BOILER

Greenstar i System Compact ^{ErP}

FOR SEALED CENTRAL HEATING SYSTEMS AND INDIRECT MAINS FED DOMESTIC HOT WATER



These appliances are for use with:

Natural Gas or L.P.G.

(Cat. II 2H 3P type C13, C33 & C53)

	Model	GC Number
Natural Gas	27i System Compact ^{ErP}	41-406-58
	30i System Compact ^{ErP}	41-406-60
L.P.G.	27i System Compact ^{ErP}	41-406-59
	30i System Compact ^{ErP}	41-406-61

If you smell gas:

- ▶ Well away from the building: call the National Gas Emergency Service on 0800 111 999.
- ▶ L.P.G. boilers: Call the supplier's number on the side of the gas tank.



CONTENTS

1	Key to symbols and safety instructions	4
1.1	Key to symbols	4
1.2	Safety precautions	5
2	Regulations	6
3	Appliance information	7
3.1	Appliance	7
3.2	Technical data	8
3.3	Energy efficiency	9
3.4	Layout	10
4	Pre-installation	11
4.1	Cleaning primary systems	11
4.2	Mains supply	12
4.2.1	Electrical supply	12
4.2.2	Gas supply	12
4.3	Water systems and pipework	12
4.3.1	S and Y plan systems	13
4.3.2	Existing installations	13
4.3.3	New installations	13
4.4	Condensate pipework	14
4.4.1	Internal connections	14
4.4.2	External connections	15
4.5	Pressure relief pipework	16
4.6	Boiler location and clearances	17
4.6.1	Installation	17
4.6.2	Installation and servicing clearances	17
4.6.3	Compartments	17
4.6.4	Bathrooms	17
4.7	Plumbing manifold	17
4.7.1	Connections	17
4.8	Flue terminal positions	19
4.9	Flue options	20
4.9.1	Flue lengths	20
4.10	Plume management terminal positions	22
4.10.1	Determine the plume management system length	23
5	Installation	24
5.1	Unpacking wall frame & ancillary items	24
5.2	Wall mounting template & flue openings	24
5.3	Unpacking the appliance	25
5.4	Pre-plumbing boiler connections	26
5.5	Hanging the boiler	27
5.6	Flue turret/adaptor installation	28
5.7	Electrical	29
5.7.1	Mounting optional plug-in controls - when optional integral diverter valve is fitted	30
6	Commissioning	34
6.1	Pre-commissioning checks	34
6.2	Filling the system	34
6.3	Water treatment	34
6.4	Starting the appliance	35

6.4.1	Boiler start up screens	36
6.5	Commissioning	37
6.5.1	Checking the gas inlet pressure	37
6.5.2	Checking the gas rate	38
6.5.3	Gas rating test	38
6.5.4	Checking for leaks during operation	38
6.6	Domestic hot water	38
6.7	CO and Combustion checks	39
6.8	Finishing commissioning	40
6.8.1	Replacing the boiler case	40
6.8.2	Securing the control panel	40
6.8.3	Fitting the fascia flap	40
6.8.4	Installing the bottom panel	40
6.8.5	Handover	41
6.8.6	Boiler guarantee	41
7	Service and spares	41
7.1	Inspection and service	41
7.2	Checking the gas inlet pressure	42
7.3	Checking flue integrity	42
7.4	Component access	43
7.5	Fan pressure test	43
7.5.1	Setting the boiler to maximum	43
7.5.2	Fan pressure	44
7.6	Flue gas analysis	44
7.7	Cleaning the heat exchanger	45
7.7.1	Cleaning the siphon	45
7.7.2	Cleaning the primary heat exchanger	46
7.8	Replacement of parts	47
7.8.1	Removing the outer case	47
7.8.2	Draining the boiler	47
7.8.3	Siphon removal	48
7.8.4	Primary sensor (CH NTC)	48
7.8.5	Maximum safety sensor	48
7.8.6	Flue overheat thermostat	48
7.8.7	AIR PRESSURE SWITCH	49
7.8.8	Auto air vent	49
7.8.9	Gas valve	49
7.8.10	Fan assembly	50
7.8.11	Air/gas flap valve assembly	51
7.8.12	ignition transformer	52
7.8.13	Electrode assembly	52
7.8.14	Burner housing, burner/ gasket	52
7.8.15	Heat exchanger	53
7.8.16	Diverter valve motor and diverter valve removal	54
7.8.17	Pump head	54
7.8.18	Pressure gauge	54
7.8.19	Boiler return sensor (NTC)	55
7.8.20	Drain tap	55
7.8.21	CH pressure relief valve	55
7.8.22	Hydraulic block removal	55
7.8.23	Bypass valve	56
7.8.24	Access to boiler control components	56
7.8.25	Replacing the control unit	56
7.8.26	Expansion vessel	57
7.9	Short parts list	59

8	Fault finding and Diagnosis	60
8.1	Internal wiring diagram	60
8.2	Heating function	61
8.3	Protection functionS	62
8.4	Information and service menus	63
8.4.1	Selecting the information menu	64
8.4.2	Selecting service menus	65
8.4.3	Menu 1 - System parameters	66
8.4.4	Menu 2 - Boiler parameters	66
8.4.5	Reset to factory settings	67
8.4.6	Menu 3 - Boiler maximum & minimum limits	67
8.4.7	Using the test menu	68
8.5	Fault codes	70

1 Key to symbols and safety instructions

1.1 Key to symbols

Warnings

	Warnings in this document are identified by a warning triangle printed against a grey background. Keywords at the start of a warning indicate the type and seriousness of the ensuing risk if measures to prevent the risk are not taken.
--	---

The following keywords are defined and can be used in this document:

- **NOTICE** indicates a situation that could result in damage to property or equipment.
- **CAUTION** indicates a situation that could result in minor to medium injury.
- **WARNING** indicates a situation that could result in severe injury or death.
- **DANGER** indicates a situation that will result in severe injury or death.

Important information

	This symbol indicates important information where there is no risk to people or property.
--	---

Additional symbols

Symbol	Meaning
1.	a numbered step in an action sequence
▶	a step in an action sequence
→	a reference to a related part in the document or to other related documents
①	a reference number to identify or refer to a part or item
.	a list entry
-	a list entry (second level)

Table 1 Symbols

Examples of additional symbols used

A numbered step in an action sequence

A sequence of numbered steps or actions carried out in a specific order to complete a task.

1. First action
2. Second action
3. Third action
- etc.

A step in an action sequence

A sequence of defined actions or steps carried out in order to complete a task.

- ▶ Action
- ▶ Next action
- ▶ etc

A reference to a related part in the document or to other related documents.

To refer the reader to a specific figure/table/section within the manual.

→ e.g. figure 1.

A reference number to identify or refer to a part or item.

In a related figure, items or parts identified by a sequential number.

List entries, first and second levels

- A single component/item
- A component/list, made up of multiple parts/items.
 - Sub component or sublist of main component/list.
 - etc.

SYMBOLS USED IN THIS MANUAL

	Domestic Hot Water
	Central Heating
	Hot Water Storage Cylinder
	Domestic Cold Water Supply
	Electrical Supply
	Gas Supply

Table 2 Commonly used symbols

PLEASE READ THESE INSTRUCTIONS CAREFULLY BEFORE STARTING INSTALLATION.

These instructions are applicable to the Worcester appliance model(s) stated on the front cover of this manual only and must not be used with any other make or model of appliance.

These instructions apply in the UK and Ireland only and must be followed except for any statutory obligations.

This appliance must be installed and serviced by a **GAS SAFE** registered, competent person. Failure to install correctly could lead to prosecution.

If you are in any doubt, contact the Worcester Technical helpline (0330 123 3366).

Please leave these instructions with the completed BENCHMARK CHECKLIST, (or a certificate confirming compliance with IS 813, Eire only) and the user manual with the owner or at the gas meter after installation or servicing.

Distance learning and training courses are available from Worcester.

The BENCHMARK CHECKLIST can be found in the back of this Installation manual.

∅	Diameter
NG	Natural Gas
LPG	Liquid Petroleum Gas
CH	Central Heating
DHW	Domestic Hot Water
DCW	Domestic Cold Water
DWTA	Domestic Water Treatment Association
PRV	Pressure Relief Valve
NTC	Negative Temperature Coefficient (sensor)
IP	Ingress Protection
RCD	Residual Current Device
TRV	Thermostatic Radiator Valve
ECV	Emergency Control Valve
WRAS	Water Regulations Advisory Scheme
SEDBUK	Seasonal Efficiency of Domestic Boilers in the United Kingdom

Table 3 Abbreviations use in this manual

1.2 Safety precautions

IF YOU SMELL GAS

A gas leak could potentially cause an explosion. If you smell gas, observe the following rules.

- ▶ Prevent flames or sparks:
 - Do not smoke, use a lighter or strike matches.
 - Do not operate any electrical switches or unplug any equipment.
 - Do not use the telephone or ring doorbells.
- ▶ Turn off the gas at the meter or regulator.
- ▶ Open windows and doors.
- ▶ Warn your neighbours and leave the building.
- ▶ Prevent anyone from entering the building.
- ▶ Well away from the building: call the National Gas Emergency Service on 0800 111 999.
- ▶ L.P.G. boilers: Call the supplier's number on the side of the gas tank.

Appliance operation:

This appliance can be used by children aged from 8 years and above and persons with reduced physical, sensory or mental capabilities or lack of experience and knowledge, if they have been given supervision or instruction concerning the use of the appliance, in a safe way, and understand the hazards involved.

Children shall not play with the appliance.

Cleaning and user maintenance shall not be made by children without supervision.



Benchmark places responsibilities on both manufacturers and installers.

The purpose is to ensure

that customers are provided with the correct equipment for their needs, that it is installed, commissioned and serviced in accordance with the manufacturer's instructions by competent persons and that it meets the requirements of the appropriate Building Regulations. The Benchmark Checklist can be used to demonstrate compliance with Building Regulations and should be provided to the customer for future reference.

Installers are required to carry out installation, commissioning and servicing work in accordance with the Benchmark Code of Practice which is available from the Heating and Hotwater Industry Council who manage and promote the scheme.

Visit centralheating.co.uk for more information.

Health and safety

The appliance contains no asbestos and no substances have been used in the construction process that contravene the COSHH Regulations (Control of Substances Hazardous to Health Regulations 1988).

Combustion and corrosive materials

Do not store or use any combustible materials (paper, thinners, paints etc.) inside or within the vicinity of the appliance.

Chemically aggressive substances can corrode the appliance and invalidate any warranty.

Fittings and modifications

Fitting the appliance and any controls to the appliance may only be carried out by a competent engineer in accordance with the current Gas Safety (Installation and Use) Regulations.

Flue systems must not be modified in any way other than as described in the fitting instructions. Any misuse or unauthorised modifications to the appliance, flue or associated components and systems could invalidate the warranty. The manufacturer accepts no liability arising from any such actions, excluding statutory rights.

Servicing

Advise the user to have the system serviced annually by a competent, qualified Gas Safe registered engineer. Approved spares must be used to help maintain the economy, safety and reliability of the appliance.

Important

The service engineer must complete the Service Record on the Benchmark Checklist after each service.

Flue System



Only use the approved Worcester Condensfit II flue system with this appliance.

Worcester original spare parts

Only use Worcester original spare parts with this appliance.

Non Worcester original spare parts will invalidate the guarantee (if applicable) and any warranty.

2 Regulations

Installation regulations

Current Gas Safety (Installation & Use) Regulations:

All gas appliances must be installed by a competent person in accordance with the above regulations.

Failure to install appliances correctly could lead to prosecution.

The appliance must be installed in accordance with, and comply to, the current: Gas Safety Regulations, IET Regulations, Building Regulations, Building Standards (Scotland) (Consolidation), Building Regulations (Northern Ireland), local water by-laws, Health & Safety Document 635 (The Electricity at Work Regulations 1989), EU Regulations No. 811/2013 - Energy Labelling and any other local requirements.

British standards

Where no specific instruction is given, reference should be made to the relevant British Standard codes of Practice.

BS7074:1 Code of practice for domestic and hot water supply

BS6891 Installation of low pressure gas pipe work up to 28mm (R1)

BS5546 Installation of gas hot water supplies for domestic purposes

EN12828 Central heating for domestic premises

BS5440:1 Flues and ventilation for gas appliances of rated heating not exceeding 70kW (net): Flues

BS5440:2 Flues and ventilation for gas appliances of rated heating not exceeding 70kW (net): Air Supply

BS7593 Treatment of water in domestic hot water central heating systems

BS6798 Installation of gas fired boilers of rated input up to 70kW (net)

L.P.G. Installations

An appliance using L.P.G. must not be installed in a room or internal space below ground level unless one side of the building is open to the ground.

Irish Standards

The relevant Irish standards should be followed, including:

- ECTI National rules for electrical installations
- IS 813:2002 for Domestic Gas Installations.

Timber Framed Buildings

Where the boiler is to be fitted to a timber framed building the guidelines laid down in BS5440: Part 1 and IGE "Gas Installations in Timber Frame Buildings" should be adhered to.

Potable Water

All seals, joints and compounds (including flux and solder) and components used as part of the secondary domestic water system must be approved by WRAS.

CH Water

Artificially softened water must not be used to fill the central heating system.

3 APPLIANCE INFORMATION

3.1 Appliance

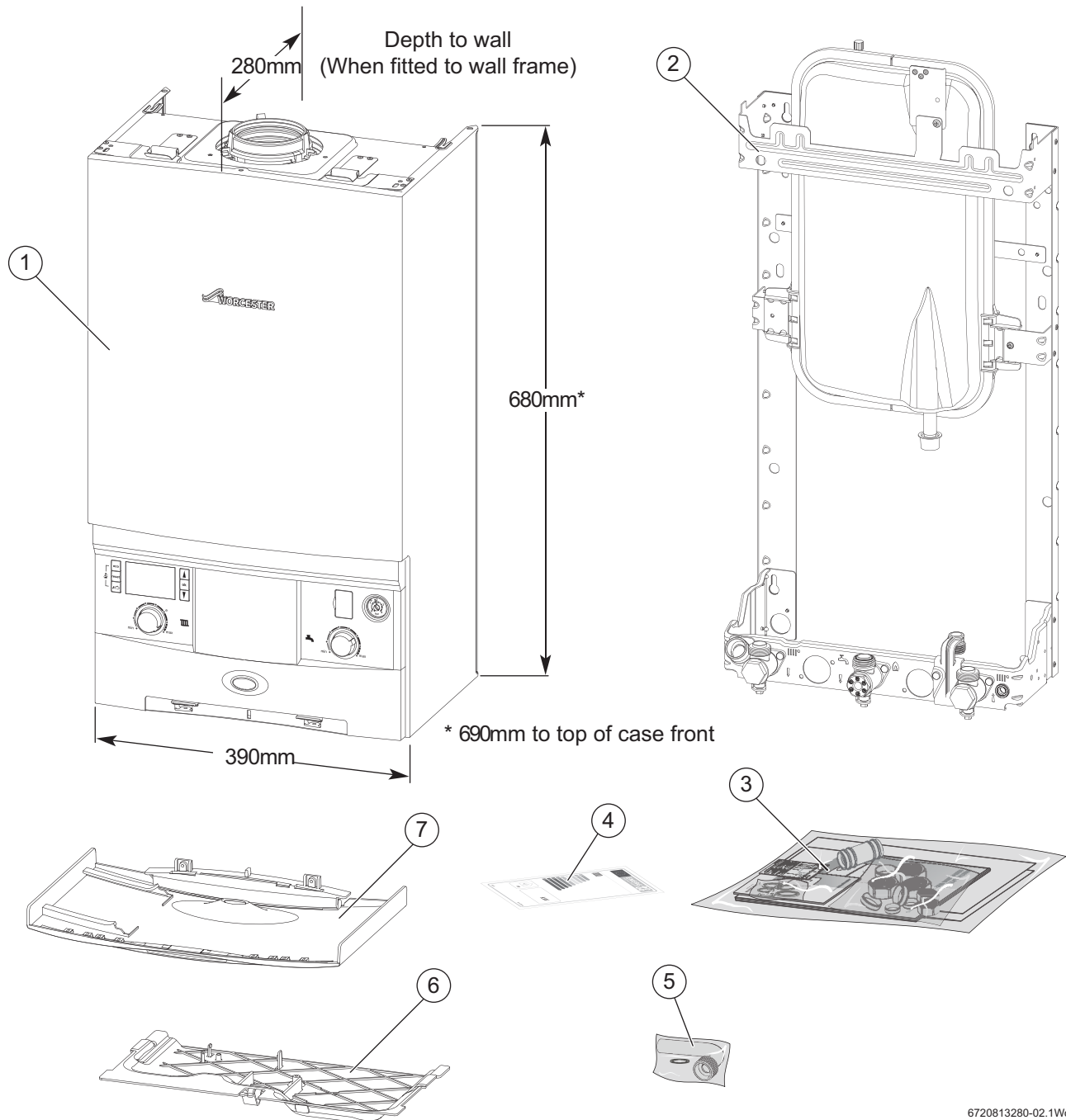

6720813280-02.1Wo

STANDARD PACKAGE

1. Wall hung gas-fired condensing system boiler for central heating and domestic hot water
2. Wall mounting frame
3. Hardware literature pack:
 - Greenstar i System Compact ^{ErP} Installation, Commissioning and Servicing Instructions
 - User guide
 - Boiler fascia guide
 - Wall mounting template
 - Condensate connector
 - Sealing Pack
4. ErP Label
5. PRV Installer connection elbow
6. Bottom panel
7. Fascia panel

3.2 TECHNICAL DATA

DESCRIPTION i System Compact	UNIT	Natural Gas		L.P.G.	
		27kW	30kW	27kW	30kW
Gas flow rate - Max. 10 minutes from lighting					
Natural Gas G20	m ³ /h	2.92	3.24		
L.P.G.	kg/h			2.1	2.33
Heating					
Minimum heat input	kW	7.15	7.15	7.15	7.15
Maximum rated heat input (net)	kW	27.58	30.65	27.58	30.65
Maximum rated heat output 40/30°C	kW	28.55	31.70	28.55	31.70
Maximum rated heat output 50/30°C	kW	28.4	31.57	28.4	31.57
Maximum rated heat output 80/60°C	kW	27.0	30.0	27.0	30.0
Maximum flow temperature	°C	82	82	82	82
Maximum possible flow temperature	°C	86	86	86	86
Maximum permissible operating pressure	bar	2.5	2.5	2.5	2.5
Available pump head at 21°C system temperature rise	m	2.0	2.0	2.0	2.0
Flue					
Flue gas temperature 80/60°C, rated/min. load	°C	67/64	70/64	69/66	72/66
Flue gas temperature 40/30°C, rated/min. load	°C	48/36	50/36	50/37	52/37
CO ₂ level at max. rated heat output (after 30 minutes)	%	9.1	9.1	10.6	10.6
CO ₂ level at min. rated heat output (after 30 minutes)	%	8.5	8.5	9.6	9.6
NOx class		5	5	5	5
NOx rating	mg/kWh	35	35	40	42
Condensate					
Maximum condensate rate	l/h	2.5	2.5	2.5	2.5
pH value, approx.		4.8	4.8	4.8	4.8
Electrical					
Electrical power supply voltage	a.c. V	230	230	230	230
Frequency	Hz	50	50	50	50
Maximum power consumption - running	W	102	109	102	109
Maximum power consumption - stand-by	W	1	1	1	1
General data					
Appliance protection rating	IP	X4D	X4D	X4D	X4D
Appliance protection rating with FW100 module fitted*	IP	IP20	IP20	IP20	IP20
Appliance protection rating with Sense II module fitted*	IP	IPX2D	IPX2D	IPX2D	IPX2D
Permissible ambient temperatures	°C	0 - 50	0 - 50	0 - 50	0 - 50
Nominal capacity of appliance	litre	2.1	2.1	2.1	2.1
Total boiler weight	kg	37.5	37.5	37.5	37.5
Lift weight	kg	27.3	27.3	27.3	27.3
SEDBUK 2005	Band	A	A	A	A
SEDBUK 2009	%	89.0	89.0	90.0	90.0

Table 4 Technical data i System Compact

* used with the optional integral diverter valve kit.

3.3 ENERGY EFFICIENCY

The following product data satisfy the requirements of the EU Regulations No. 811/2013 and No. 812/2013 supplementing Directive 2010/30/EU.

Product data	Symbol	Unit	7733600060	7733600062	7733600061	7733600063
Product type	-	-	27i System Compact ^{ErP} NG	30i System Compact ^{ErP} NG	27i System Compact ^{ErP} LPG	30i System Compact ^{ErP} LPG
Condensing boiler	-	-	Yes	Yes	Yes	Yes
Low temperature boiler	-	-	No	No	No	No
B1 boiler	-	-	No	No	No	No
Cogeneration space heater (CHP)	-	-	No	No	No	No
Combination heater	-	-	No	No	No	No
Rated heat output	P _{rated}	kW	27	30	27	30
Seasonal space heating energy efficiency	η _s	%	92	92	92	92
Energy efficiency class	-	-	A	A	A	A
Useful heat output						
At rated heat output and high temperature regime ¹⁾	P ₄	kW	27	30	27	30
At 30% of rated heat output and low temperature regime ²⁾	P ₁	kW	8.9	9.9	8.9	9.9
Useful efficiency						
At rated heat output and high temperature regime ¹⁾	η ₄	%	88.2	88.2	88.2	88.2
At 30% of rated heat output and low temperature regime ²⁾	η ₁	%	97.3	97.3	97.3	97.3
Auxiliary electricity consumption						
At full load	e _{lmax}	kW	0.033	0.04	0.033	0.04
At part load	e _{lmin}	kW	0.014	0.014	0.014	0.014
In standby mode	P _{SB}	kW	0.001	0.001	0.001	0.001
Other items						
Standby heat loss	P _{stby}	kW	0.078	0.078	0.078	0.078
Ignition burner power consumption	P _{ign}	kW	0	0	0	0
Emissions of nitrogen oxides	NO _x	mg/kWh	32	32	32	32
Annual energy consumption	Q _{HE}	kWh	-	-	-	-
Sound power level, indoors	L _{WA}	dB(A)	53	55	53	55

Table 5 Product data for energy consumption according to the EU regulations no. 811/2013 and no. 813/2013

1) High-temperature regime means 60 °C return temperature at heater inlet and 80 °C feed temperature at heater outlet.

2) Low temperature means for condensing boilers 30 °C, for low-temperature boilers 37 °C and for other heaters 50 °C return temperature (at heater inlet).

3.4 LAYOUT

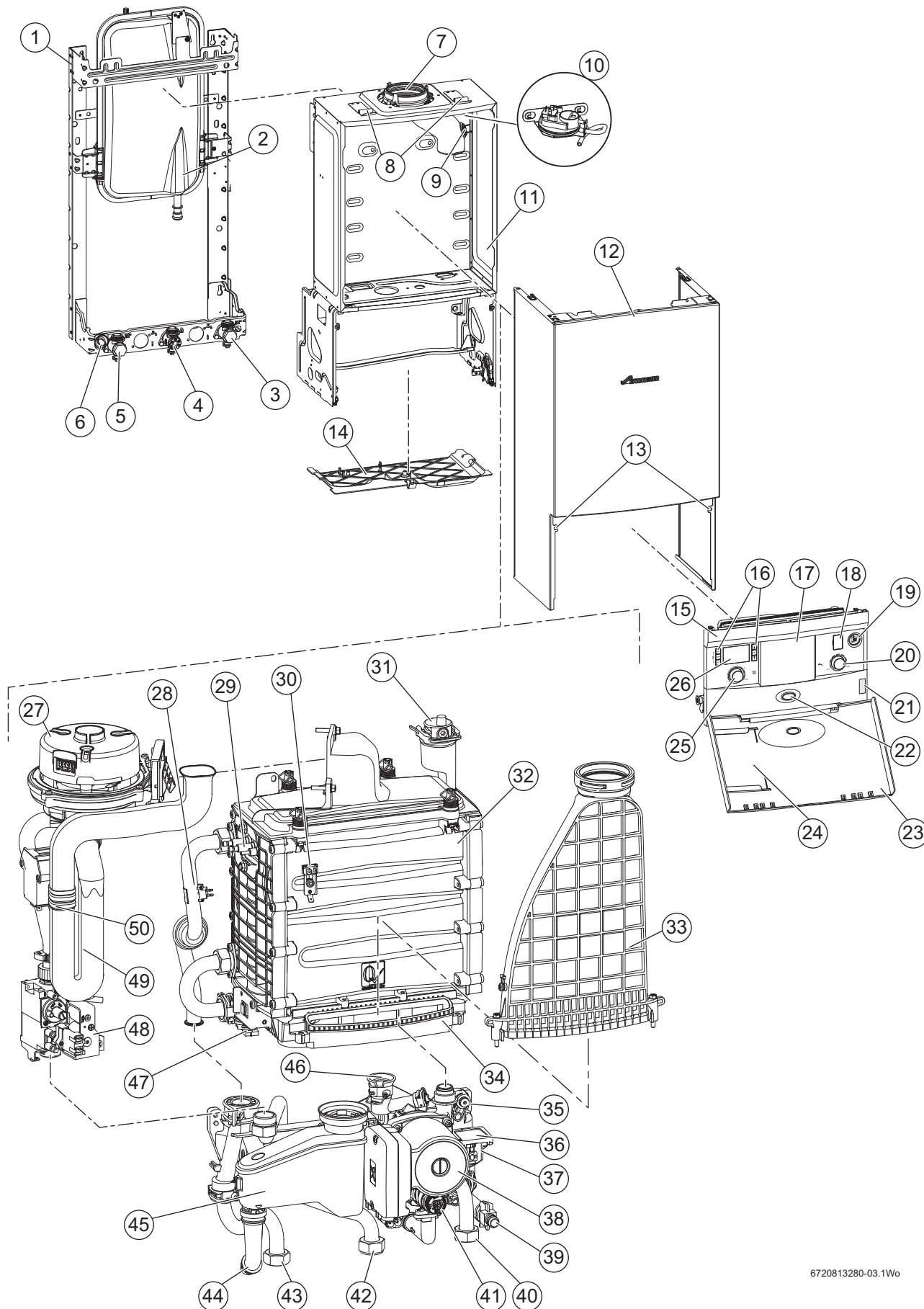

6720813280-03.1W6

Fig. 1 Main boiler components

1	Wall mounting frame	26	Boiler display
2	Expansion vessel	27	Fan
3	CH return isolator	28	Flow temperature sensor (NTC)
4	Gas inlet isolator	29	Electrode assembly
5	CH flow isolator	30	Maximum safety sensor NTC
6	Condensate connection	31	Auto air vent
7	Flue connector	32	Aluminium Silicon Heat exchanger
8	Case retaining clips	33	Flueway
9	Flue overheat thermostat	34	Sump assembly
10	Air Pressure Switch	35	Pressure gauge connection point
11	Main superstructure	36	Diverter valve actuator blank
12	Case	37	Diverter valve body
13	Case retaining screws	38	Modulating pump
14	Bottom panel	39	Drain point
15	Control, top panel	40	CH return connection to service valve
16	Menu buttons	41	PRV
17	Blank for optional programmer	42	Gas connection to service valve
18	Diagnostic port (for Worcester service engineers)	43	CH flow connection to service valve
19	Pressure gauge	44	Condensate discharge pipe
20	DHW temperature control*	45	Siphon
21	Boiler identification label	46	Expansion vessel connection point
22	Operation/fault diagnostic light (blue)	47	Return temperature sensor (NTC)
23	Control panel flap	48	Gas valve
24	Boiler fascia guide location	49	Combustion air inlet
25	CH temperature control	50	Ignition transformer

Table 6 Boiler components



* DHW temperature control.
The optional Integral Diverter Valve kit with cylinder sensor is required to enable the hot water temperature control to be used.
The table below lists:

- ▶ the accessories that can be fitted when the integral diverter valve is fitted.
- ▶ with which accessory the DHW control is exclusively responsible for the stored DHW temperature.

Accessory	DHW control exclusively responsible	
	Integral diverter valve	External diverter valve
DT10 RF Digistat	YES	N/A
DT10 RF Optimiser	YES	N/A
DT20	YES	N/A
DT20 RF	YES	N/A
FR110	NO	N/A
FW100	NO	N/A
Comfort I RF	YES	N/A
Comfort II RF	YES	N/A
Comfort	YES	N/A
Sense I	YES	N/A
Sense II	NO	N/A
Worcester Wave	YES	N/A

Table 7



The FR110, FW100 and Sense II provide an additional level of control over the DHW set point, allowing the DHW set point to be adjusted at these controls and not only via the DHW temperature control knob on the boiler's fascia. With these controls, the boiler fascia's control knob, becomes the maximum temperature limiter. If this is set too low, the DHW set point on the control cannot be achieved.

4 PRE-INSTALLATION

4.1 CLEANING PRIMARY SYSTEMS



CAUTION:
▶ ISOLATE THE MAINS SUPPLIES BEFORE STARTING ANY WORK AND OBSERVE ALL RELEVANT SAFETY PRECAUTIONS.



NOTICE: All the following pre-installation sections must be read and requirements met before starting the boiler or flue installations.



NOTICE: Water treatment
▶ Debris from the system can damage the boiler and reduce efficiency. Failure to comply with the guidelines for the use of water treatment with the appliance will invalidate the appliance guarantee and contravene the Building Regulations.
▶ It is recommended that you fit a primary water cleanser to the system. Worcester recommends fitting a filter that will help remove both magnetite and non-magnetic debris.

BEFORE CLEANING THE SYSTEM:

- ▶ Ensure that the system and pipework is in good working order.
- ▶ **Where possible keep the existing boiler/circulating pump in place when flushing the system.**

FOLLOW THE GUIDANCE OF BS7593:

Treatment of water in domestic hot water central heating and also the flushing guidelines below.



NOTICE: Artificially softened water must not be used to fill the central heating system.

FLUSHING THE SYSTEM

- ▶ Fill the system with cold water and check for leaks.
- ▶ Open all drain cocks and drain the system.
- ▶ Close drain cocks and add a suitable flushing agent **compatible with aluminium** at the correct strength for the system conditions in accordance with the manufacturer's instructions.
The pH value of the system water must be less than 8 or the appliance guarantee will be invalidated.
- ▶ Circulate the flushing agent before the boiler is fired up.
- ▶ Run the boiler/system at normal operating temperature as directed by the manufacturer of the flushing agent.
- ▶ Drain and thoroughly flush the system to remove the flushing agent and debris.
- ▶ It may be necessary to use a power flushing machine to aid the cleansing procedure in some circumstances.
- ▶ Close the drain cocks and refill with fresh water and a suitable inhibitor.
- ▶ Vent any air from the boiler and system.

INHIBITOR

Add a suitable inhibitor or combined inhibitor/anti-freeze, if the system is exposed to freezing conditions, to the heating system in accordance with the DWTA code of practice and manufacturer's guidelines.



WARNING: Sealing agents

- ▶ Normally the addition of sealing agents to the system water is not permitted as this can cause problems with deposits left in the heat exchanger.
- ▶ In cases where all attempts to find a micro leak have failed, Worcester, Bosch Group supports the use of Fernox F4 leak sealer.

WATER TREATMENT PRODUCTS

Suitable water treatment products can be obtain from the following manufacturers:

- **FERNOX** - 0870 601 5000 or www.fernox.com
- **SENTINEL** - 0800 389 4670 or www.sentinel-solutions.net

ARTIFICIALLY SOFTENED WATER

It is possible to have an ion exchange water softener fitted to the cold water system of the property. However, the boiler requires an untreated cold water connection taken from the mains supply, before the water softener, to the primary water filling point of the heating system.

4.2 MAINS SUPPLY

4.2.1 ELECTRICAL SUPPLY

- Supply: 230V - 50 Hz
- Cable: PVC insulated 0.75mm² (24 x 0.2mm) rated to 90°C
- External 3A fuse to BS1362.
- The boiler must be earthed.
- This boiler must not be connected to a 3 phase supply.
- IPX4D.



NOTICE: IP rating change;

This is reduced to IP20 if the following control is fitted FW100 7 716 192 067.

This is reduced to IPX2D when the Sense II 7 738 111 064 is fitted.

- Wiring must comply with the latest edition of BS 7671 (IET wiring regulations).

4.2.2 GAS SUPPLY

To ensure that the equipment is in good working order and can meet the gas flow and pressure requirements, in addition to the demand from any other appliance being served, the following applies:

- Boilers using Natural Gas (NG) must be connected to a governed meter.
- Liquid Petroleum Gas (LPG) must be connected to a regulator.
- Installation and connection of the gas supply to the boiler must be in accordance with BS6891.
- Gas pipe sizing should be calculated to ensure no more than the permitted mbar drop between the meter/governor to the appliance inlet. (→ Commissioning section).
- The meter or regulator and pipe work to the meter must be checked, preferably by the gas supplier.

4.3 WATER SYSTEMS AND PIPEWORK

PLASTIC PIPEWORK:

- Any plastic pipework must have a polymeric barrier with 600mm (min.) length of copper pipe before being connected to the boiler.
- Plastic pipework used for underfloor heating must be correctly controlled with a thermostatic blending valve, limiting the temperature of the circuits to approximately 50°C.

PRIMARY SYSTEMS CONNECTIONS/VALVES:

- All system connections, taps and mixing valves must be capable of sustaining a pressure up to 3 bar.
- Radiator valves should conform to BS2767:10.
- All other valves should conform to BS1010.
- Thermostatic radiator valves (TRV's) must be fitted to all rooms except bathrooms and the room with the room thermostat.
- A drain cock is required at the lowest point(s) in the system.
- An air vent is required at the high point(s) in the system.



The boiler is equipped with an internal by-pass.

The internal bypass is not intended to be a substitute for an external system bypass.

An external automatic bypass should be used if the system flow can be significantly adjusted or stopped by zone valves and thermostatic radiator valves (TRV).

SEALED PRIMARY SYSTEM:



NOTICE: Artificially softened water must not be used to fill the central heating system.

- The CH sealed system must be filled using a WRAS approved filling loop or comply with figure 2 for system fill.
- Where the system volume is more than 100 litres or exceeds 2.65 bar at maximum heating temperature, an extra expansion vessel (2) must be fitted as close as possible to the appliance in the central heating return.
- Pressurise the extra expansion vessel (2) to the same figure as the expansion vessel built into the appliance.
- **Do not use galvanised pipes or radiators.**

SYSTEM FILL

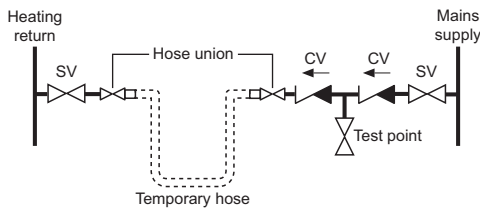

CV = Check Valve AA = Auto Air vent
SV = Stop Valve CV = Check Valve

SYSTEM MAKE UP

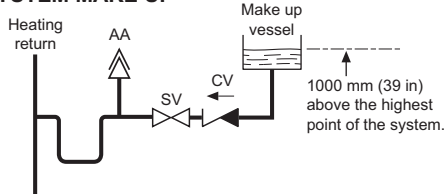

6720644743-08.2.Wo

Fig. 2 System fill

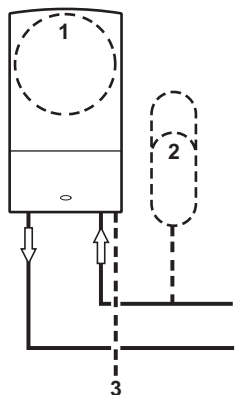

6720644743-08.1.Wo

Fig. 3 Additional expansion vessel

- [1] Appliance expansion vessel - CH
- [2] Extra expansion vessel - CH return
- [3] Pressure relief discharge

OPTIONAL DIVERTER VALVE

This boiler is designed to operate on a sealed system only. The boiler will require a second return pipe from the water cylinder to the wall mounting frame and terminate in 15mm copper pipe.

4.3.1 S AND Y PLAN SYSTEMS



The boiler is equipped with an internal by-pass. The internal bypass is not intended to be a substitute for an external system bypass. An external automatic bypass should be used if the system flow can be significantly adjusted or stopped by zone valves and thermostatic radiator valves (TRV).

NOTICE: Automatic bypass
▶ An automatic bypass valve is required when fitting an S-plan type system with two-port valves.

NOTICE: Drain cock
▶ A drain cock should be fitted at the lowest point(s) of the heating circuit and beneath the appliance.

4.3.2 EXISTING INSTALLATIONS

S PLAN LAYOUT

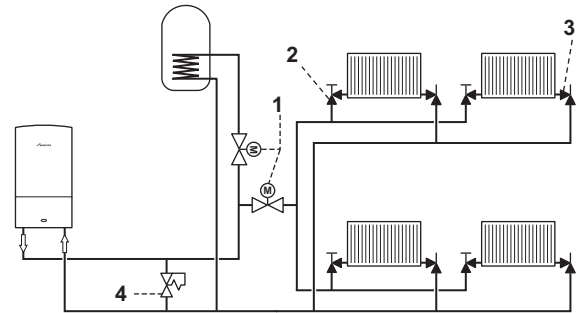

Y PLAN LAYOUT

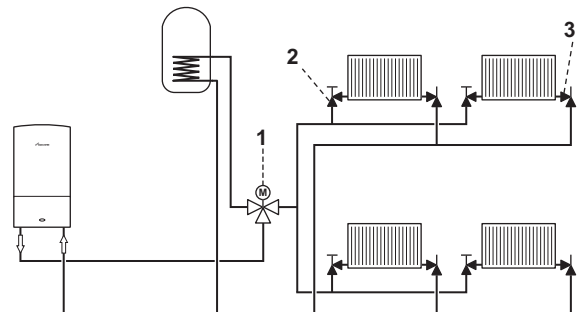

SYSTEM LAYOUT WITH OPTIONAL INTERNAL DIVERTER VALVE (NOT SUPPLIED WITH BOILER)

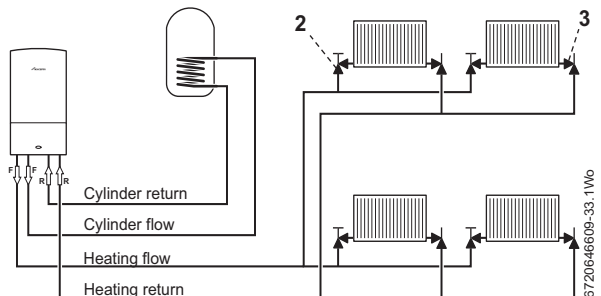

6720646609-33.1.Wo

- [1] Diverter valve
- [2] Radiator valve (flow)
- [3] Lock shield valve (return)
- [4] Bypass

4.3.3 NEW INSTALLATIONS

S PLAN PLUS LAYOUT

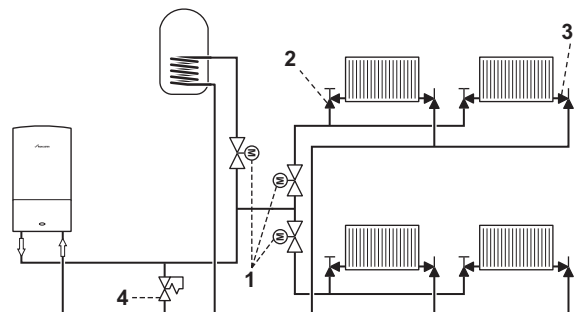

AVAILABLE PUMP HEAD



In order to save as much energy as possible and the minimise the possibility of water circulation noise, a low characteristic should be chosen.

The pump map can be selected within 2.1C in the Boiler settings menu list:

- **0** (pump variable speed setting)
- **1** (constant pressure low)
- **2** (constant pressure low/middle)
- **3** (constant pressure middle/high)
- **4** (constant pressure high)

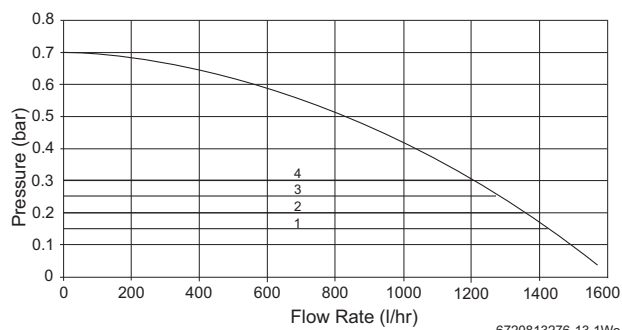

The factory setting is:

4 (constant pressure high)

CONSTANT PRESSURE HEAD

If the constant pressure head option (1 - 4) is chosen, the differential pressure between the CH flow and return will be kept at the corresponding value. When the CH system is cold and the radiator TRVs are fully open, the pump will be running faster to try and maintain the pressure differential. When the TRVs start to close and the resistance of the CH system increases, the pump speed reduces to maintain the pressure.

The setting (1 - 4) to be selected is dependent upon the resistance and heat load of the CH system. The higher these are, the higher the pressure constant

4.4 CONDENSATE PIPEWORK



NOTICE:

- ▶ Where a new or replacement boiler is being installed, access to an internal "gravity discharge" point should be one of the factors considered in determining boiler location.
- ▶ The condensate pipe must be nominally 22mm Ø plastic pipe.
- ▶ The condensate pipework must fall at least 52mm per metre towards the outlet and should take the shortest practicable route.
- ▶ Ensure there are no blockages in the pipe run.

Key to condensate illustrations	
1	Condensate discharge from boiler
2	Soil and vent stack
3	Minimum 450mm and up to three storeys
4	Visible air break at plug hole
5	Sink or basin with integrated overflow
6	75mm sink waste trap
7	Condensate pump
*	Condensate trap of 75mm already incorporated into the boiler

4.4.1 INTERNAL CONNECTIONS

In order to minimise risk of freezing during prolonged cold spells, the following methods of installing condensate drainage pipe should be adopted, in order of priority.

Wherever possible, the condensate drainage pipe should be routed and terminated so that the condensate drains away from the boiler under gravity to a suitable internal foul water discharge point such as an internal soil and vent stack. A suitable permanent connection to the foul waste pipe should be used.

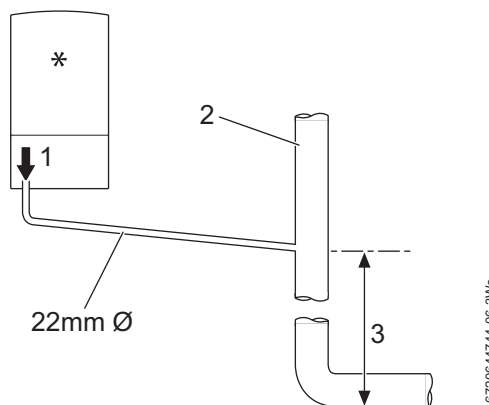

Fig. 4 Disposal to soil vent stack

Alternatively if the first option is not possible an internal kitchen or bathroom waste pipe, washing machine waste pipe etc. can be used. Ensure that the condensate drain pipe is connected "down stream" of the waste trap.

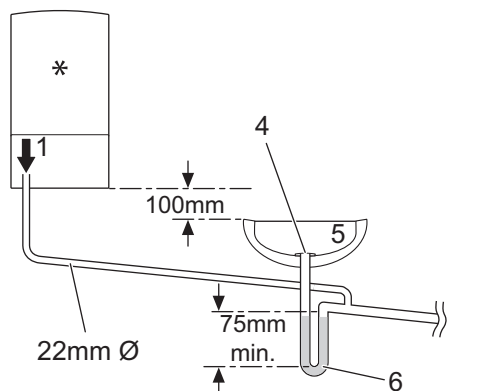

Fig. 5 Disposal to a waste pipe

CONDENSATE PUMP

Where “gravity discharge” to an internal termination is not physically possible, or where very long internal runs would be required to reach a suitable discharge point, condensate should be removed using a proprietary condensate pump, of a specification recommended by the boiler or condensate pump manufacturer.

The pump outlet pipe should discharge to a suitable internal foul water discharge point such as an internal soil and vent stack, internal kitchen or bathroom waste pipe, washing machine waste pipe etc. A suitable permanent connection to the foul waste pipe should be used.

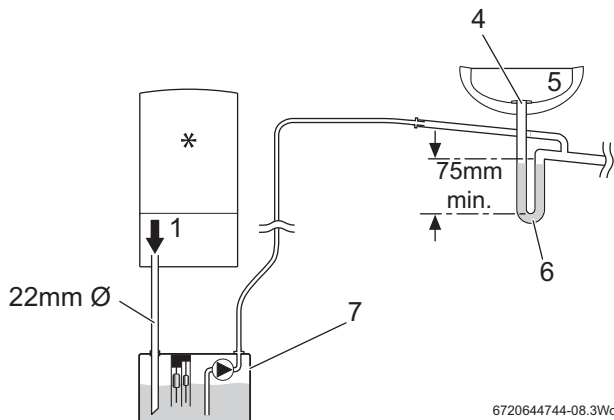

Fig. 6 Condensate pump disposal

4.4.2 EXTERNAL CONNECTIONS

NOTICE: Freezing conditions

- ▶ When the position of the boiler prevents internal routing, we recommend installing a CondenseSure siphon to significantly reduce the risk of freezing.
- ▶ Pipework length should be kept to a minimum and the route as vertical as possible.
- ▶ Weather proof insulation must be used, if not using a CondenseSure siphon.

NOTICE: Condensate waste

- ▶ Care should be taken when siting a soak-away to avoid obstructing existing services.

Continued - Key to condensate illustrations	
8	PVCu strap on fitting
9	100mm Ø minimum plastic pipe
10	Drainage holes
11	Limestone chippings
12	Bottom of sealed tube
13	Insulate and increase pipe size
14	Pipework transition
15	External air break
16	Air gap
17	External rain water pipe into foul water
18	43mm 90° male/female bend
*	Condensate trap of 75mm already incorporated into the boiler

If no other discharge method is possible then the use of an externally run condensate drainage pipe terminating at a suitable foul water discharge point, or purpose-designed soak away, may be considered. If this method is chosen then the following measures should be adopted:

- ▶ Use a CondenseSure siphon to help prevent the condensate freezing.
- ▶ The external run be kept as short as possible and not exceed 3 metres.

- ▶ The pipe should be run internally as far as possible before going externally and the pipe diameter should be increased to 32mm before it passes through the wall to the exterior. The pipe should be insulated using suitable waterproof and weather resistant insulation, if not using a CondenseSure siphon.
- ▶ The external pipe should take the shortest and least exposed route to the discharge point, and should “fall” as steeply as possible away from the boiler, with no horizontal runs in which condensate might stand.
- ▶ The use of fittings, elbows etc. should be kept to a minimum and any internal “burrs” on cut pipework should be removed so that the internal pipe section is as smooth as possible.

FITTING AN EXTERNAL AIR BREAK

- Refer to figure 7 when a rain water down pipe is used to dispose of condensate.
- An air break must be installed in the 43mm pipework, between the boiler condensate outlet and the drainpipe, outside the property, to avoid flooding during adverse weather conditions.

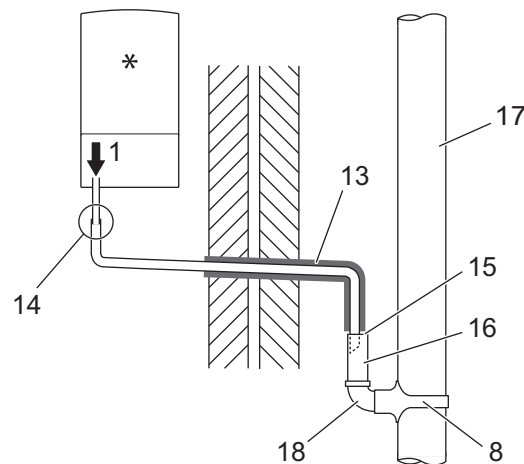

Fig. 7 Disposal into a rainwater down pipe

i Condensate drainage pipe can be run above or below ground.

Where the pipe terminates over an open drain or gully, the pipe should terminate below the grating level, but above water level, in order to minimise “wind chill” at the open end.

The use of a drain cover (such as those used to prevent blockage by leaves) may offer further protection from wind chill.

Pipe drainage will be improved if the end is cut at 45° as opposed to a straight cut.

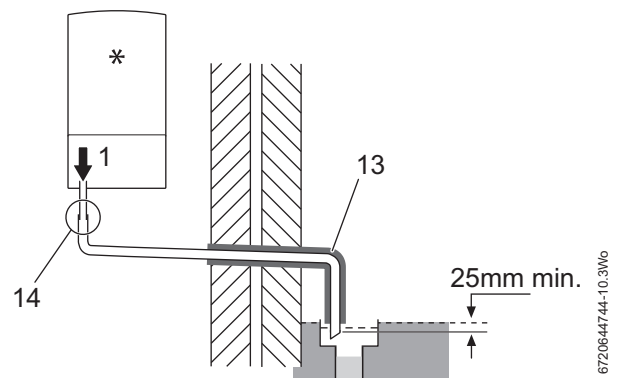

Fig. 8 External disposal

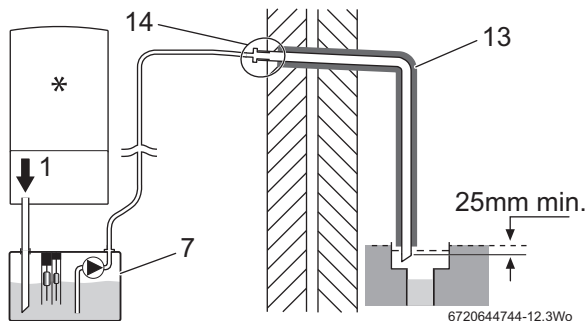

Fig. 9 Condensate pump to external disposal

CONDENSATE SOAK AWAY

- The condensate drainage pipe may be run above or below the ground to the soak away. The examples shown on this page run above ground.
- The soak away must use a 100mm Ø plastic tube with two rows of three 12mm holes on 25mm centres and 50mm from the bottom of the tube. The holes must face away from the house.
- The tube must be surrounded by at least 100mm of limestone chippings to a depth of 400mm.



Minimum hole size for the condensate soak away must be 400mm deep by 300mmØ.

In situations where there are likely to be extremes of temperature or exposure, the use of a proprietary trace-heating system for external pipework, incorporating an external frost thermostat, should be considered. If such a system is used, the requirement to use 32mm pipe does not apply. However, all other guidance above and the instructions for the trace heating system, should be closely followed.



NOTICE: Unheated internal areas.

- ▶ Internal pipe runs in unheated areas such as lofts, basements and garages should be treated as external runs and consideration should be given to using a CondenseSure siphon.

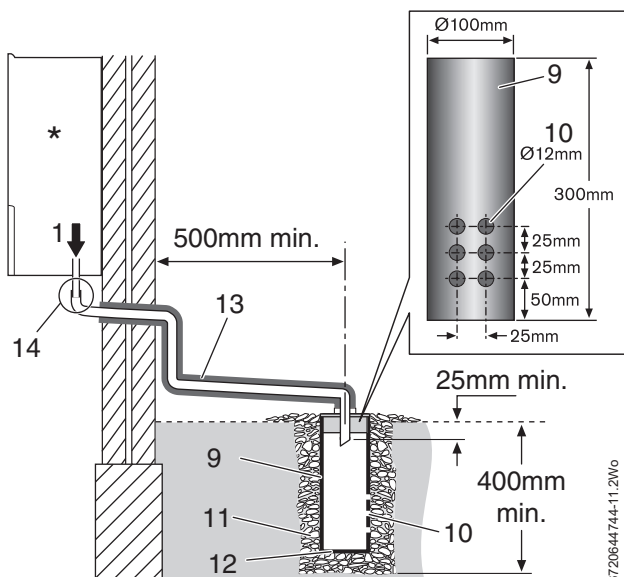

Fig. 10 Soak away

4.5 PRESSURE RELIEF PIPEWORK



NOTICE:

- ▶ The pressure relief valve is a safety device for the boiler and if activated may discharge boiling water or steam through the relief valve drain pipe.
- ▶ Care should be taken when siting the outlet pipe so that it does not cause an obstruction or discharge above a window, entrance or other public access where it could cause a hazard.

- The pressure relief drain pipe (1) from the boiler should be at least 15mm diameter copper pipe and run downwards, away from any electrical equipment or other hazard, preferably to an external drain or soak away.
- The pressure relief drain pipe (1) should be finished with a partial bend, near the outlet to face the external wall (as shown) to help prevent freezing.

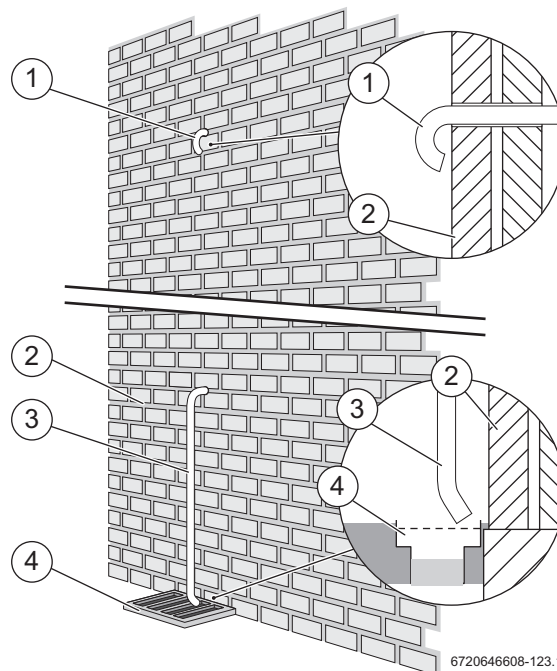

Fig. 11 Pressure relief pipework

- [2] Outside wall
- [1, 3] PRV drain pipe
- [4] External drain

4.6 BOILER LOCATION AND CLEARANCES

4.6.1 Installation

This appliance is only suitable for installing internally within a property at a suitable location onto a fixed, rigid surface at least the same size as the appliance and capable of supporting the appliance weight.



No surface protection is required against heat transfer from the appliance.

The appliance must be installed where:

- An engineer can gain clear and safe access to work on the product or component, including making adequate provision for visual inspection of flues in voids.
- The homeowner can gain clear and safe access to the controls, check, top up or reset the appliance.
- Products in loft cavities must have permanent fixed lighting, a permanent fixed retractable ladder and a fixed floor area sufficient to allow access for normal use and servicing directly under and around the product and between and the access hatch.

4.6.2 INSTALLATION AND SERVICING CLEARANCES

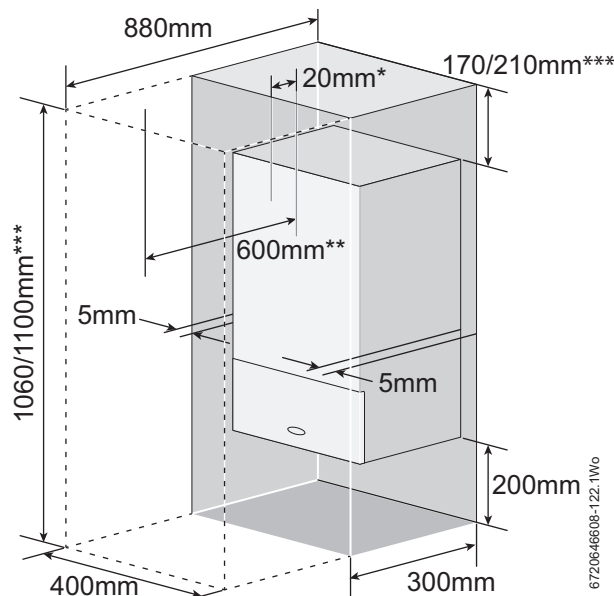

Fig. 12 Unventilated compartment

- [*] Minimum clearance to removable door
- [**] Minimum clearance required for servicing
- [***] Height for either 60/100 flue or 80/125 flue

4.6.3 COMPARTMENTS

Follow the requirements of BS6798 and BS5440 Part 2 and note:

- Minimum clearances must be maintained.
- An access door is required to install, service and maintain the boiler and any ancillary equipment.
- If fitting the boiler into an airing cupboard use a non-combustible material to separate the boiler from the airing space.
The material can be perforated up to a maximum hole size of 13mm.

4.6.4 BATHROOMS

Please check the IP rating of any control to be used on this appliance. Only certain controls can be fitted when the appliance is inside of the shaded area.

An appliance with blanking panel or controls that do not change the IP rating can be installed in zone 2.

Additional RCD (Residual Current Device) protection may be required. Consult the latest version of BS7671 (IET wiring regulations).

2* Without the end wall, zone 2 must extend 600mm from the bath

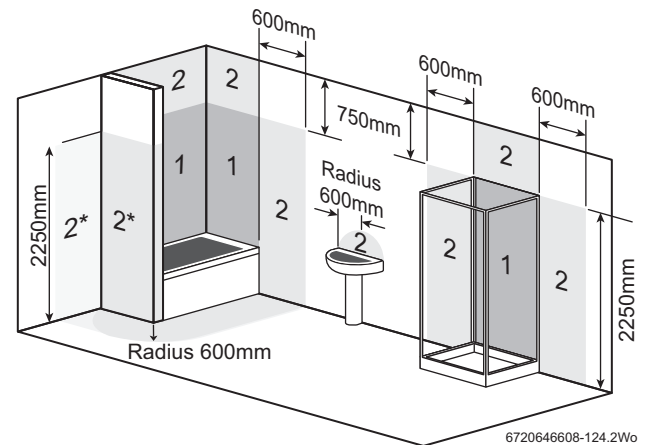

Fig. 13 Bathroom installations

4.7 PLUMBING MANIFOLD

4.7.1 CONNECTIONS

- If the boiler pipes are to be run behind the appliance ensure that the pipes pass either side of the expansion vessel as shown in figure 15.



Further guidance on pipe routing can be found printed on the boiler template (supplied with the boiler).

- For further ease of fitting, an optional Vertical Pre-piping Assembly kit is available, comprising three pre-formed copper pipes and a cross bonding strip. Part number: 7 716 192 712.

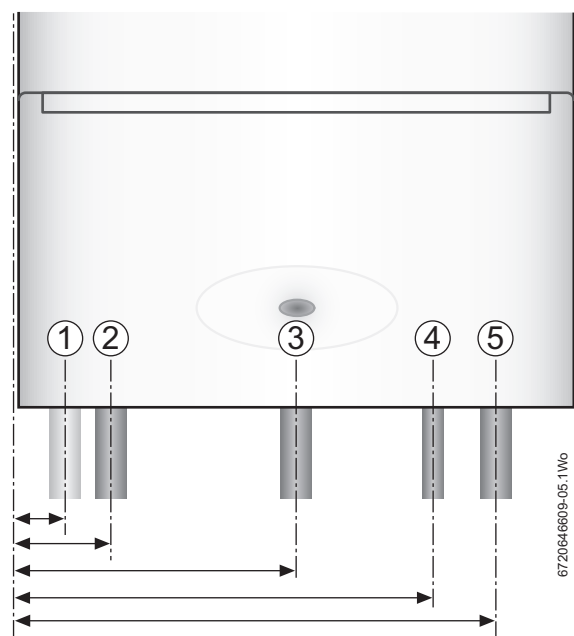

Fig. 14 Pipe dimensions

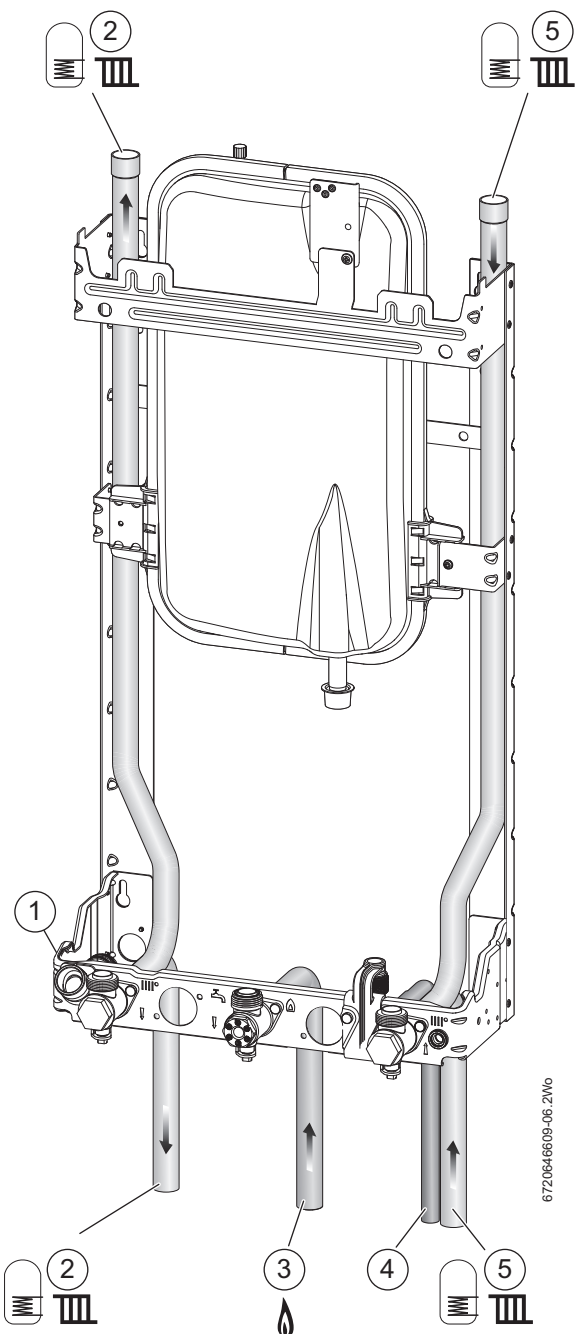

Fig. 15 Plumbing manifold

#	Function	From left case edge	Diameter of pipe
1	Condensate	33mm	22mm
2	CH Flow	65mm	22mm
3	Gas	195mm	22mm
4	Pressure Relief Valve	291mm	15mm
5	CH Return	325mm	22mm

Table 8 Key to figures 14 & 15

Heating System	22mm compression fittings
Gas	22mm compression fittings
Condensate	22mm rubber push fit connector
PRV	15mm (fittings not supplied)

Use the fittings supplied in the Hardware literature pack.

4.8 FLUE TERMINAL POSITIONS

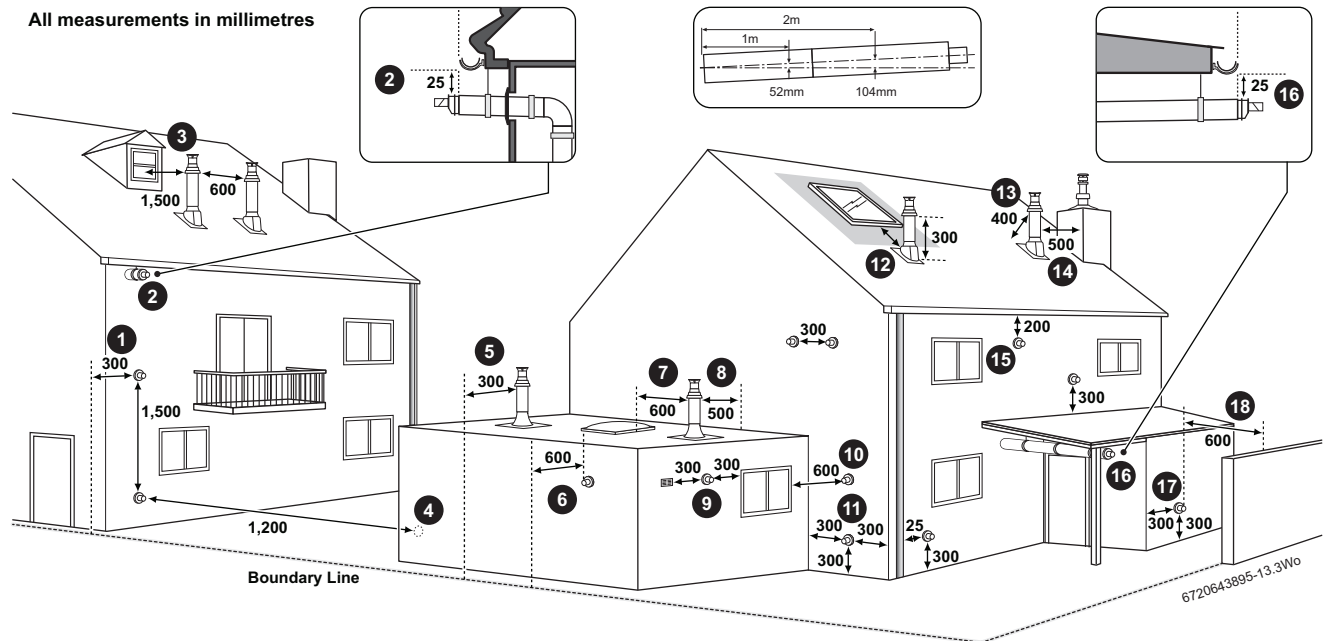

Fig. 16 Flue terminal positions

NOTICE:

- ▶ All measurements are the minimum clearances required.
- ▶ Terminals must be positioned so to avoid combustion products entering the building.
- ▶ Support the flue at approximately one metre intervals and at a change of direction, use suitable brackets and fittings. (flue bracket 100mm part number: 7 716 191 177, flue brackets 100mm x 6 part number: 7 716 191 178, flue bracket 125mm part number: 7 716 191 179).

Key to illustration

1. 300mm adjacent to a boundary line.
2. The dimension below eaves, gutters, pipes and drains can be reduced to 25mm, as long as the flue terminal is extended to clear any overhang. External flue joints must be sealed with suitable silicon sealant.
3. 1,500mm between a vertical flue terminal and a window or dormer window.
4. 1,200mm between terminals facing each other.
5. Vertical flue clearance, 300mm adjacent to a boundary line unless it will cause a nuisance. BS 5440:Part 1 recommends that care is taken when siting terminal in relation to boundary lines
6. 600m distance to a boundary line, unless it will cause a nuisance. BS 5440:Part 1 recommends that care is taken when siting terminal in relation to boundary lines.
7. 600mm minimum clearance from a skylight to a vertical flue.
8. Vertical flue clearance, 500mm to non-combustible building material, and 1,500mm clearance to combustible building material.
9. 300mm above, below and either side of an opening door, air vent or opening window.
10. 600mm diagonally to an opening door, air vent or opening window.
11. 300mm to an internal or external corner. This does not apply to building protrusions less than 450mm.
12. 2,000mm below a Velux window, 600mm above or to either side of the Velux window.
13. 400mm from a pitched roof or 500mm in regions with heavy snow fall.
14. 500mm clearance to any vertical structure on a roof, 600mm to room sealed flue or 1,500 to an open flue.
15. 200mm below eaves and 75mm below gutters, pipe and drains.
16. The dimension below eaves, balconies and car ports can be reduced to 25mm, as long as the flue terminal is extended to clear any overhang. External flue joints must be sealed with suitable silicon sealant.
17. Flue clearance must be at least 300mm from the ground. Terminal guards must be fitted if the flue is less than 2 metres from the ground or if a person could come into contact with the flue terminal.
18. 600mm distance to a surface facing a terminal, unless it will cause a nuisance. BS 5440: Part 1 recommends that care is taken when siting terminals in relation to surfaces facing a terminal.



Note:

- ▶ Installations in car ports are not recommended.
- ▶ The flue cannot be lower than 1,000mm from the top of a light well due to the build up of combustion products.
- ▶ Dimensions from a flue terminal to a fanned air inlet to be determined by the ventilation equipment manufacturer.
- ▶ A flue terminal guard should be fitted over a terminal, if persons could come into contact with the terminal, or it could be subject to damage and where the terminal is less than 2,000mm from the finished floor level.

4.9 FLUE OPTIONS

WARNING: Flue systems
 ▶ Only use Worcester, Bosch approved flue systems, no other manufacturer's flue systems have been approved for use with Worcester appliances.

CAUTION: Non accessible flue systems:
 ▶ Where a flue system is not going to be accessible, provision must be made for service and inspection.
 ▶ Voids containing concealed flues must have at least one inspection hatch no less than 300mm square.
 ▶ Flue joints within the void must not be more than 1.5 metres from the edge of the inspection hatch.
 ▶ Inspection hatches should be located at changes of direction.
 ▶ If this is not possible, bends should be viewable from both directions.

NOTICE: Effective flue lengths:
 ▶ each 90° bend is equivalent to 2 metres of straight flue
 ▶ each 45° bend is equivalent to 1 metre of straight flue

i Plume management kits are available for the 60/100 horizontal flue system,
 Part number 7 716 191 086.
 Refer to the manual supplied with the Plume Management kits for complete installation instructions

Part number	Flue	Description
7 716 191 082	60/100	Telescopic horizontal flue assembly
7 716 191 171	60/100	Longer telescopic horizontal flue assembly
7 733 600 048	60/100	Horizontal high level telescopic flue kit
7 719 003 702	80/125	Telescopic horizontal flue assembly
7 719 002 430	60/100	Vertical flue assembly
7 719 002 431	80/125	Vertical flue assembly

Table 9 Flue kit part numbers

4.9.1 Flue lengths

The flue systems have different maximum flue lengths

The Greenstar series has the option of two horizontal 60/100 RSF (telescopic and longer telescopic) and one horizontal 80/125 RSF (telescopic) flue system and two vertical RSF (60/100 or 80/125) flue systems:

Refer to the following example Flue options for the maximum flue lengths.



Horizontal high level flue assembly

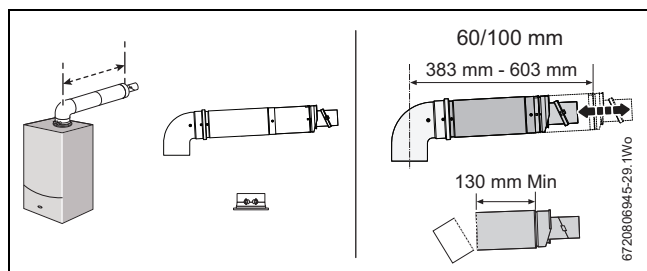

	Flue length (mm)	
	60/100	80/125
Horizontal high level telescopic flue assembly	202 - 603	N/A

Table 10

TELESCOPIC HORIZONTAL FLUE ASSEMBLY

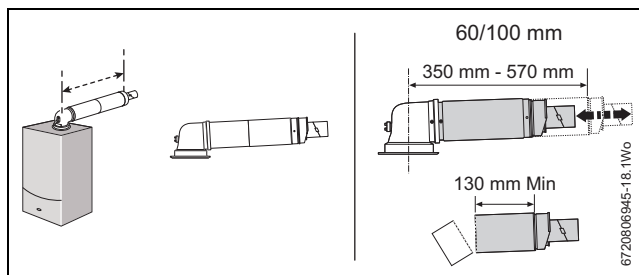

	Flue length (mm)	
	60/100	80/125
Telescopic horizontal flue assembly	180 - 570	405 - 600
Longer telescopic horizontal flue assembly	570 - 790	N/A

Table 11

Extended horizontal flue

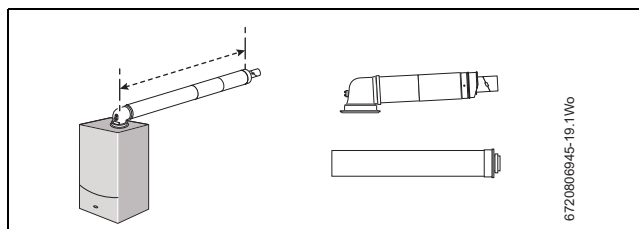

	Maximum flue length (mm)	
	60/100	80/125
Extended horizontal flue	6,000	15,000

Table 12

Horizontal flue with additional elbow (1 x 90° bend)

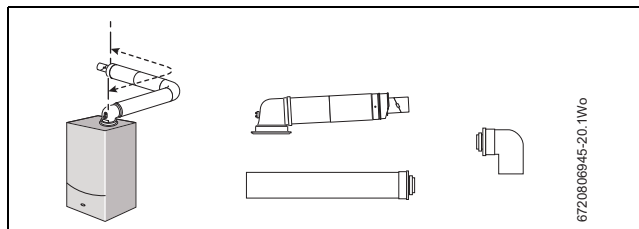

	Maximum flue length (mm)	
	60/100	80/125
Horizontal flue with 1 x 90° bend	4,000	13,000

Table 13

Horizontal flue with additional elbows (2 x 90° bends)

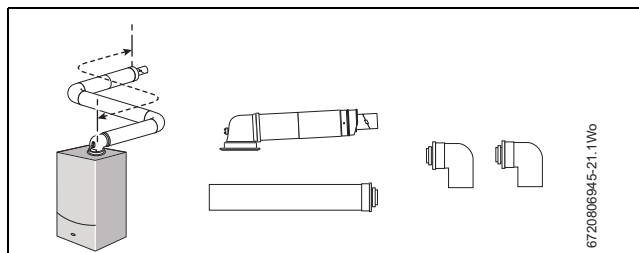

	Maximum flue length (mm)	
	60/100	80/125
Horizontal flue with 2 x 90° bends	2,000	11,000

Table 14

High level horizontal flue

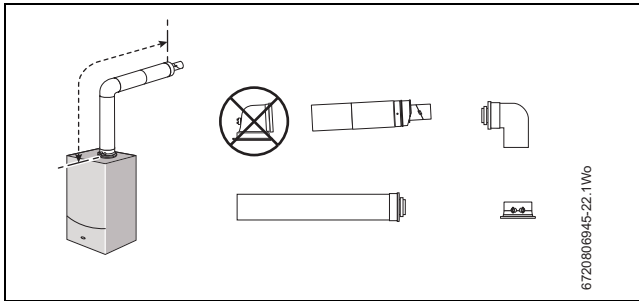

	Maximum flue length (mm)	
	60/100	80/125
High level horizontal flue	6,000	15,000

Table 15

High level horizontal flue with additional elbows

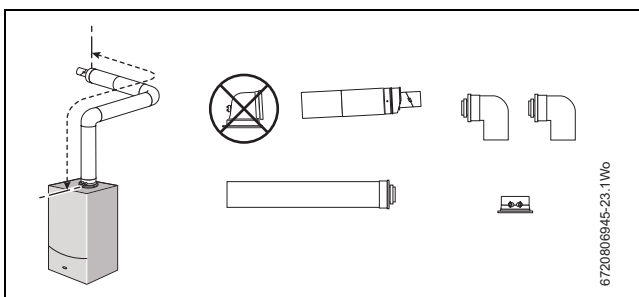

	Maximum flue length (mm)	
	60/100	80/125
High level horizontal flue with 2 x 90° bends	4,000	13,000

Table 16

High level horizontal flue with additional elbows

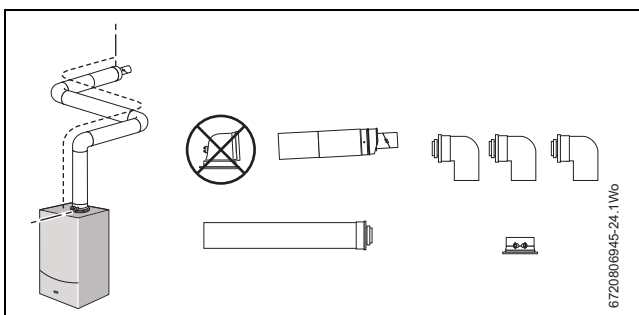

	Maximum flue length (mm)	
	60/100	80/125
High level horizontal flue with 3 x 90° bends	2,000	11,000

Table 17

Vertical balanced flue assembly

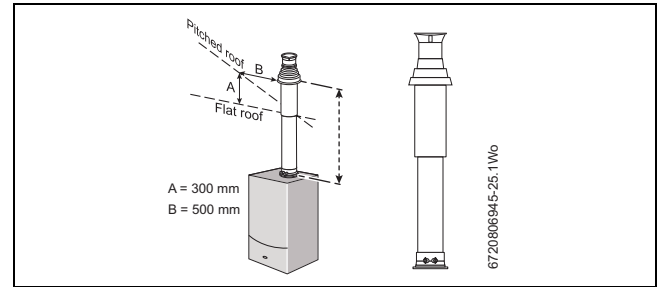

	Maximum flue length (mm)	
	60/100	80/125
Vertical balanced flue assembly	6,000	15,000

Table 18

Vertical balanced flue with elbow offset (2 x 90° bends)

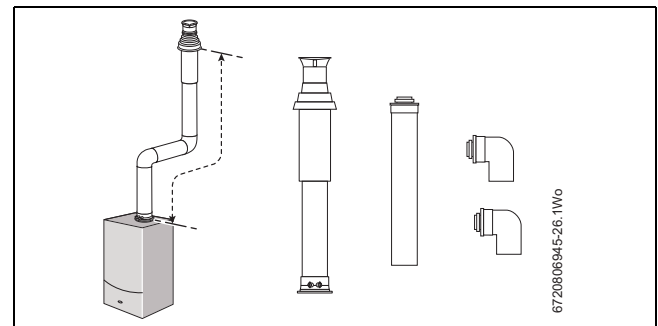

	Maximum flue length (mm)	
	60/100	80/125
Vertical balanced flue with 2 x 90° bends	2,000	11,000

Table 19

Vertical balanced flue with elbow offset (2 x 45° bends)

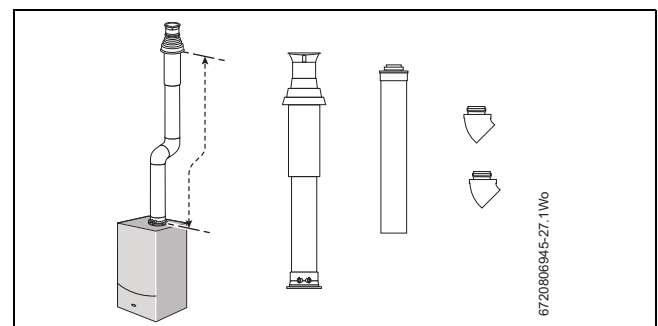

	Maximum flue length (mm)	
	60/100	80/125
Vertical balanced flue with 2 x 45° bends	4,000	13,000

Table 20

4.10 PLUME MANAGEMENT TERMINAL POSITIONS

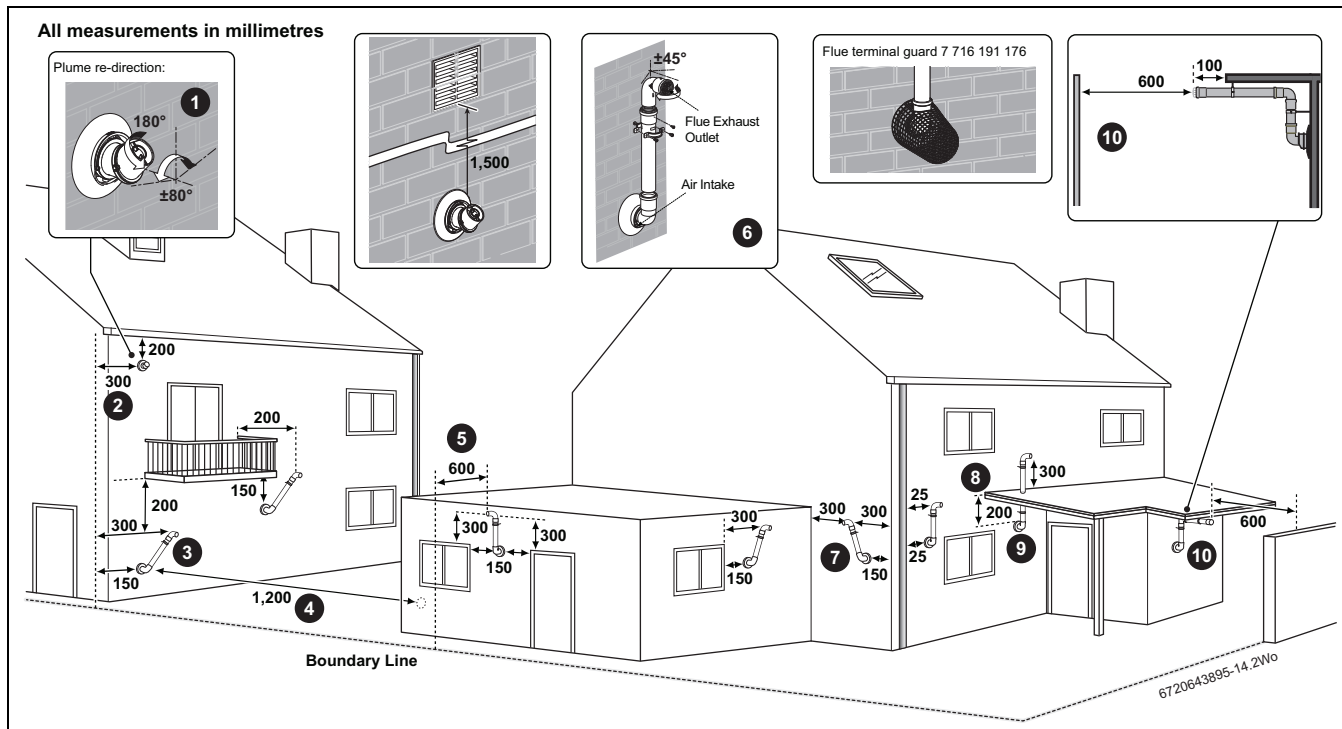

Fig. 17 Plume terminal positions

- i** Maximum and minimum plume management lengths:
- ▶ A minimum distance of 500mm must be maintained between the plume management outlet and the flue air intake.
 - ▶ The maximum plume management length is 4.5 metres for the appliances detailed on the front of this manual.
 - ▶ The 45° bend is equivalent to 0.75 metres of straight plume management and the 90° bend is equivalent to 1.5 metres.

- NOTICE:**
- ▶ All measurements are the minimum clearances required.
 - ▶ Refer to previous page for all concentric flue terminal positions unless the flue position is specified on the figure above “Plume terminal positions”.
 - ▶ Terminals must be positioned so to avoid combustion products entering the building.
 - ▶ Support the flue at approximately one metre intervals and at a change of direction, use suitable brackets and fittings.

Key to illustration

1. This feature allows some basic plume re-direction options on a standard telescopic horizontal flue terminal.
300mm minimum clearances to a opening e.g. window.
However the minimum clearances to an opening in the direction that the plume management is facing, must be increased to 1,500mm.
Where the flue is less than 150mm to a drainpipe and plume re-direction is used the deflector should not be directed towards the drainpipe.
2. 300mm adjacent to a boundary line.
3. Plume Management kit air intake can be reduced to 150mm providing the flue exhaust outlet is no less than 300mm adjacent to a boundary line.
4. 1,200mm between terminals facing each other.
5. 600mm distance to a boundary line, unless it will cause a nuisance. BS 5440:Part 1 recommends that care is taken when siting terminal in relation to boundary lines.
6. Using a Plume Management kit the air intake measurement can be reduced to 150mm providing the flue exhaust outlet has a 300mm clearance. The initial horizontal run from the terminal elbow must have a minimum 10° fall back, (stop tabs in the elbow prevent less than 10°) to the appliance for proper disposal of condensate. Any further horizontal runs can be 3°.
7. Internal/external corners. The air intake clearance can be reduced to 150mm providing the flue exhaust outlet has a 300mm clearance.
8. Clearances no less than 200mm from the lowest point of the balcony or overhang.
9. 1,200mm from an opening in a car port on the same wall e.g. door or window leading into the dwelling.
10. 600mm distance to a surface facing a terminal, unless it will cause a nuisance. BS 5440: Part 1 recommends that care is taken when siting terminals in relation to surfaces facing a terminal.

- Note:**
- ▶ Installations in car ports are not recommended.
 - ▶ The flue cannot be lower than 1,000mm from the top of a light well due to the build up of combustion products.
 - ▶ Dimensions from a flue terminal to a fanned air inlet to be determined by the ventilation equipment manufacturer.

4.10.1 DETERMINE THE PLUME MANAGEMENT SYSTEM LENGTH

Effective straight flue length with plume management	
Minimum plume length (M)	Maximum plume length (M)
500mm	4,500mm
Max flue length (L) 5,000mm	Max flue length (L) 2,200mm



Note: Measurement M plume length
 ► M must be a minimum of 500mm and must not exceed 4,500mm for a 60mm plume management system used with the horizontal Ø 60/100mm flue.

MINIMUM PLUME MANAGEMENT LENGTH

The minimum plume length should be calculated to ensure that the air inlet and exhaust have a minimum distance of 500mm between them (→ figure 18).

The plume management can be in any configuration, within the parameters of the plume management installation instructions, as long as it does not terminate inside the shaded area.



WARNING: Minimum plume management length.
 The minimum distance of 500mm must be maintained between air inlet and exhaust.
 ► Do not terminate the plume management inside the shaded area shown in figure 18

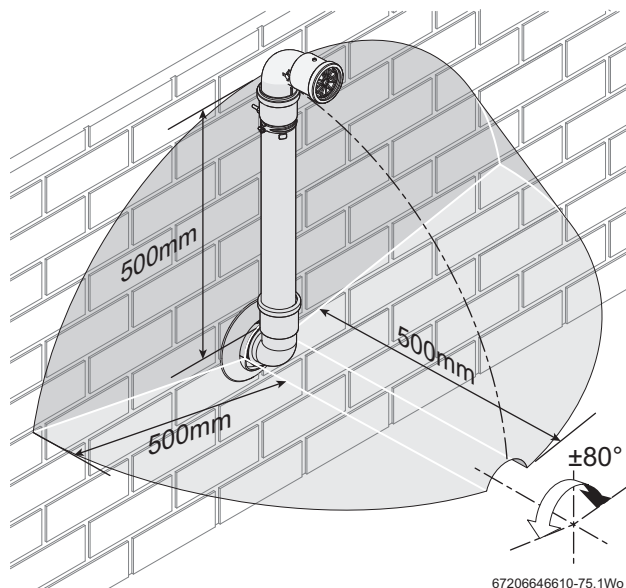

Fig. 18 Terminal exclusion zone



NOTICE: Cutting the 500mm pipe
 If the 500mm plume management pipe kit is cut, an additional elbow will be required to join the pipework.
 ► The Plume management extension kit contains the components required for such a configuration.

FLUE LENGTH VERSUS PLUME MANAGEMENT LENGTH

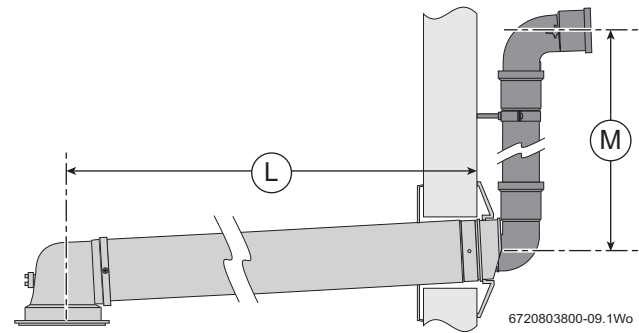

Fig. 19 Effective lengths L and M

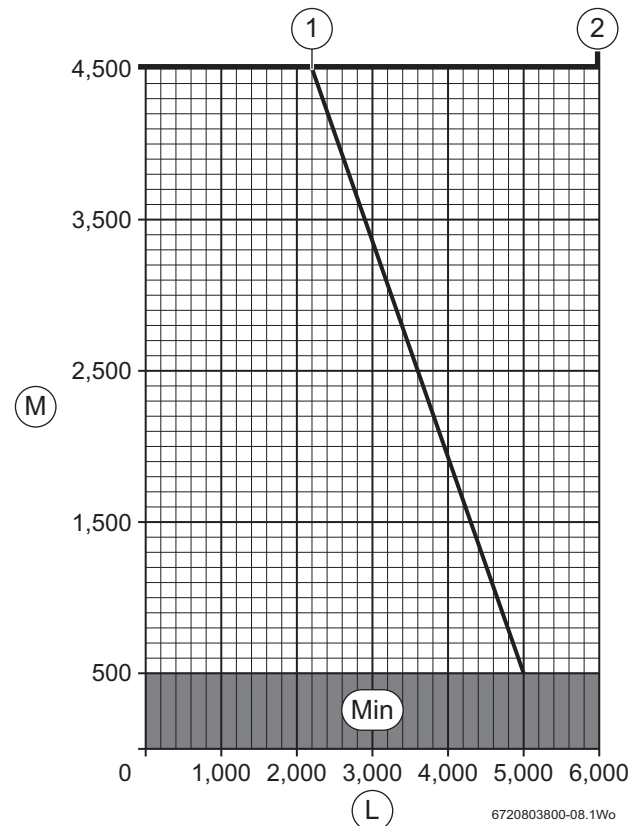

Fig. 20 Effective flue lengths versus plume management lengths

- [Min] Minimum plume kit length 500mm
- [M] Plume management length allowed (mm)
- [L] Effective flue length (mm)
- [1] 27 & 30 i System Compact ERP data line
- [2] Maximum plume length for all boilers

Refer to figure 20 to determine the appropriate plume length (M) versus the flue length (L).

The lengths for both plume and flue are the effective lengths, which includes the effective length of any bends plus the straight lengths.

The graph can be used to calculate:

- **Effective flue length** if a specific effective plume length is required.
- **Effective plume length** if a specific effective flue length is required.

5 INSTALLATION

WARNING: All the previous “Pre-Installation” sections must be read and the requirements met before starting boiler or flue installation.

5.1 UNPACKING WALL FRAME & ANCILLARY ITEMS

CAUTION: LIFTING AND CARRYING

- ▶ Only lift a manageable weight, or ask for help.
- ▶ Bend your knees and keep your back straight with feet apart, when lifting or putting down heavy objects.
- ▶ DO NOT lift and twist at the same time.
- ▶ Lift and carry object close to the body.

- ▶ Remove the retaining straps from the carton.
- ▶ Open the four carton flaps and unpack as follows:
 1. Remove items 2, 3, 4 and 5 from the cardboard tray.
 2. Remove the wall mounting frame (1) and cardboard tray together.

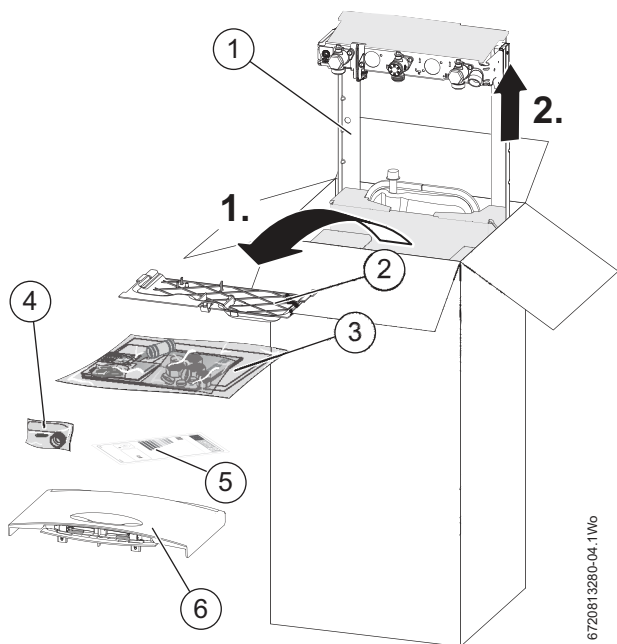

Fig. 21 Unpacking

- [1] Wall mounting frame
- [2] Bottom panel
- [3] Hardware literature pack
- [4] PRV elbow
- [5] ErP Label
- [6] Front fascia

IMPORTANT HANDLING INSTRUCTIONS:

- It is advised that two people are used to carry the carton from the van to the point of delivery.
- Once the carton has been delivered, the outer carton is removed first. Care should be taken when releasing the straps. If a sharp implement is used make sure the outer carton is not pierced and that the implement is used in such a way so that it may not cause personal injury.
- All sharp objects must be covered or the blade retracted after use and put away in a safe place. Care should be taken when lifting the boiler from the base and the proper technique for safe lifting of any heavy object should be strictly observed.

Additional requirements for roof space installation:

- The boiler should be first unpacked before ascending a ladder to the loft space.
- Two sets of steps should be used.
- Two people should share the lifting of the boiler up to the loft hatch, where the boiler is entered into the loft space tilted and slid on its back into the loft.
- Once the appliance is removed from its packaging check the contents against the packing list.

NOTICE:

- ▶ Before installing the appliance, ensure that the system has been cleaned as explained on page 11.

5.2 WALL MOUNTING TEMPLATE & FLUE OPENINGS

WARNING: BEFORE DRILLING

- ▶ Ensure that there are no pipes, electrical cables, damp proof courses or other hazards.

SAFETY:

All relevant safety precautions must be undertaken. Protective clothing, footwear, gloves and safety goggles must be worn as appropriate.

FIXING THE WALL MOUNTING FRAME:

- ▶ The boiler wall mounting template shows the relative positions of the flue and the top and bottom fixings of the wall mounting frame.
 1. Fix the wall mounting template to the wall in the desired position.
 2. Drill 4 holes for the wall mounting frame through the template.

The wall mounting template has been sized to allow for minimum clearances of 5mm sides, 200mm base and 30mm above a 100mm diameter flue elbow.

REAR FLUE OUTLET

- ▶ The figure 22 shows the boiler wall mounting template with the flue centre lines of both the 100mm and 125mm flue systems.
- 3. Mark the centre line of the flue to be used (3); the external diameter of the hole can also be marked if required.
- ▶ If a 100mm diameter flue is to be used, a 125mm diameter hole is required. However, if using the weather sealing collar by pushing it through from inside the property, then a 150mm diameter hole is required to accommodate this.
- ▶ The flue turret of the 100mm flue has an in-built 3° angle.
- ▶ If extensions are to be added then the complete flue must rise at an angle of 3°.
- ▶ Drill the hole preferably using a core drill.

SIDE OUTLET:

- 4. Mark from the centre line of the wall mounting template to the wall that the flue will pass through (4).
- ▶ Allow for a rise of 52mm per metre length of flue, to give a 3° angle.
- ▶ Clear any debris from the site.

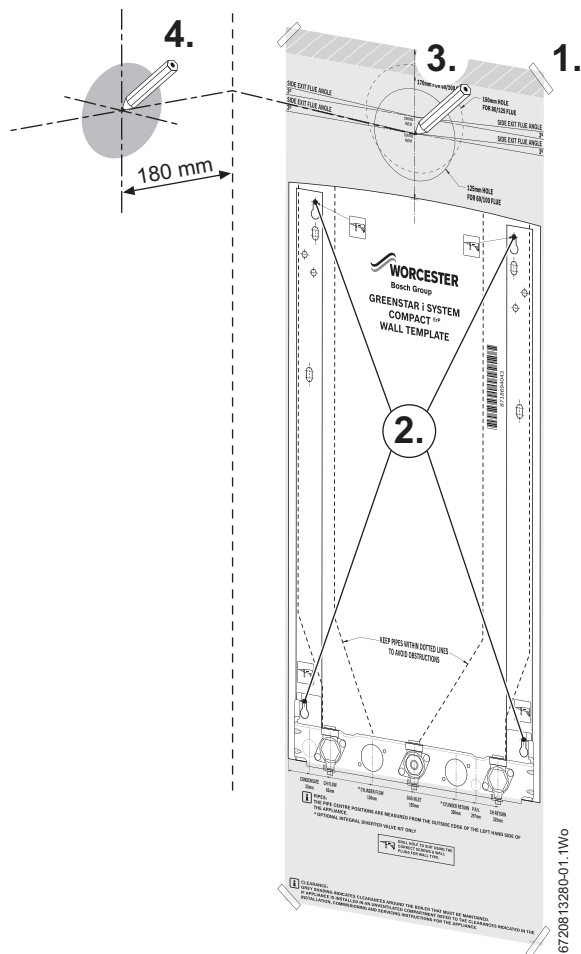

Fig. 22 Marking the flue position

- ▶ Remove the wall mounting template.
- ▶ Secure the wall mounting frame to the wall with the appropriate fittings for the boiler weight and wall type.
- ▶ Remove and discard the red plastic dust cap from the expansion vessel pipe before hanging the boiler.

5.3 UNPACKING THE APPLIANCE

1. Remove outer carton (1) and place safely away from the working area.
2. Remove the inner sleeve (2) leaving all other cardboard inserts and base (3) in place.
3. Remove the protective wrapping (4) from the boiler.

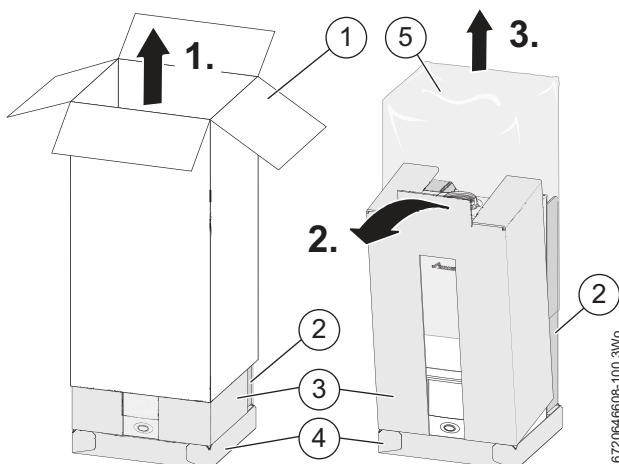

Fig. 23 Remove the carton

4. Remove the protective cardboard (5) from over the isolating valves.
5. Remove the protective cardboard (6) from around the expansion vessel.

6. Remove the inner packing (2) from the back of the boiler.
7. Lie the boiler on the floor ensuring that the V shaped cardboard insert (8) is in place.

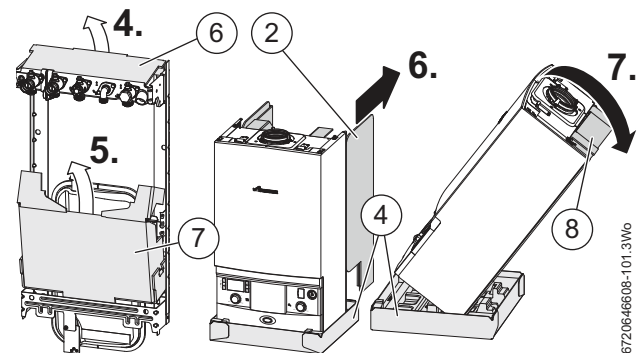

Fig. 24 Finish unpacking

REMOVING THE OUTER CASE

▶ Before the case can be removed, the control panel must be moved into the service position, i.e. hinged open.

1. Remove the two screws underneath the fascia securing the control panel.
2. Pull the catches forward to release.
3. Pull the bottom of the fascia forward and out to release the top of the control panel.
4. Hinge open the control panel into the service position
5. Refer to figure 25 and release the two screws securing the lower part of the case.
6. Release the spring clips at the top of the boiler.
7. Slide the case off the frame and store safely out of the way.

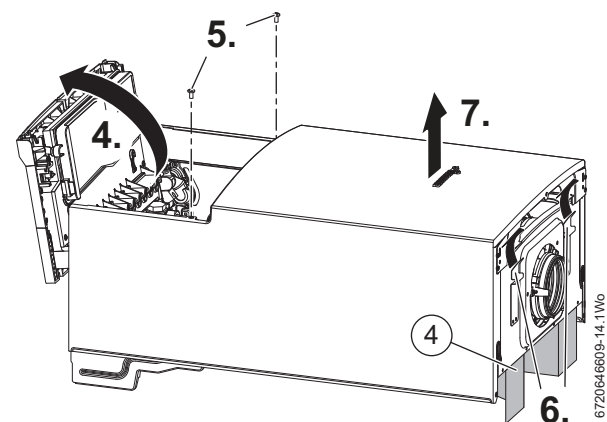
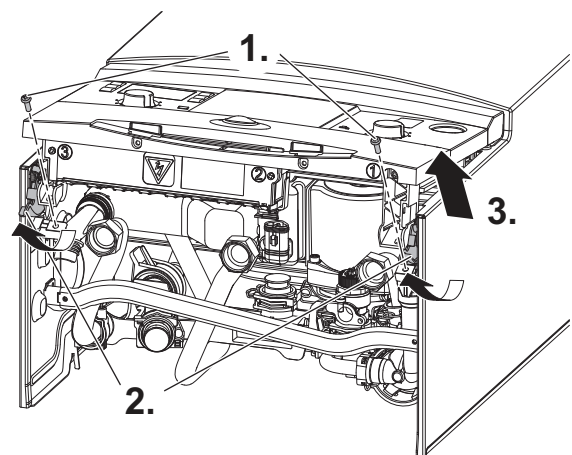

Fig. 25 Releasing the control panel

INSTALLATION



Refer to Figure 26. The connector (1) in the wiring harness is for use on other appliances and does not provide a function on this Greenstar iSystem Compact ERP

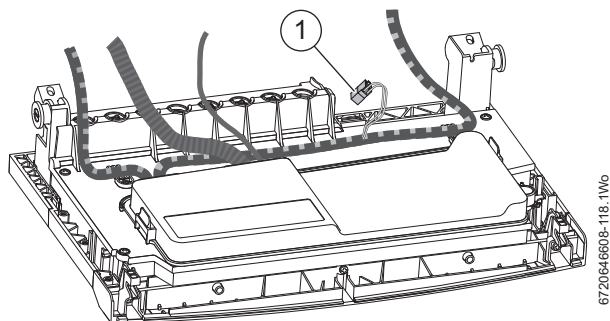

Fig. 26 Unused connector

- ▶ Remove any packaging within the boiler and the packaging base (3).
- ▶ Leave the V shaped support (5) in place until the boiler is ready to be hung on the wall frame, then remove.

5.4 PRE-PLUMBING BOILER CONNECTIONS



CAUTION:

- ▶ Isolate the mains gas supply before starting any work and observe all relevant safety precautions.
- ▶ Be aware of plastic components when using a naked flame on pipework.

GAS AND WATER CONNECTIONS



WARNING: Bonded washer for gas

- ▶ The bonded washer must be used on the gas pipe isolating valve connection.

- ▶ Connect the system pipes using the compression nuts and olives supplied in the Literature/Hardware pack.

1. CH flow (22mm)
2. Gas inlet - bonded washer (22mm)
3. CH return (22mm)

- ▶ Fit sealing washers to service valves before hanging boiler.

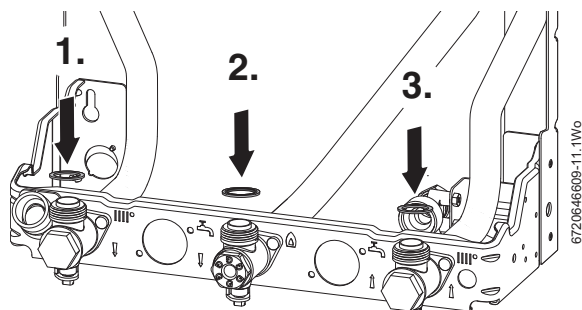

Fig. 27 Sealing washers

PLUMBING THE CONDENSATE DRAIN PIPE

- ▶ Fit the condensate discharge pipe as far back as possible to the wall to ensure easy fitting of the boiler bottom panel.
- ▶ Route the condensate pipe to an appropriate discharge point, refer to section 4.4.
- ▶ Plumb up to the wall frame with 22mm pipe.
- ▶ Ensure that there is enough pipe to insert 25mm into the rubber hose connector.
- ▶ Attach the connector to the condensate drain pipe.

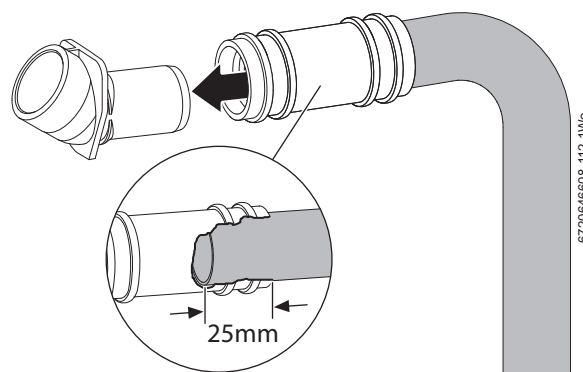

Fig. 28 Condensate connection

PRV PRE-PLUMBING CONNECTION

1. Fit the PRV pre-plumbing connector to the PRV locator bracket as shown in the figure below.

The elbow is supplied in the Hardware/Literature pack.

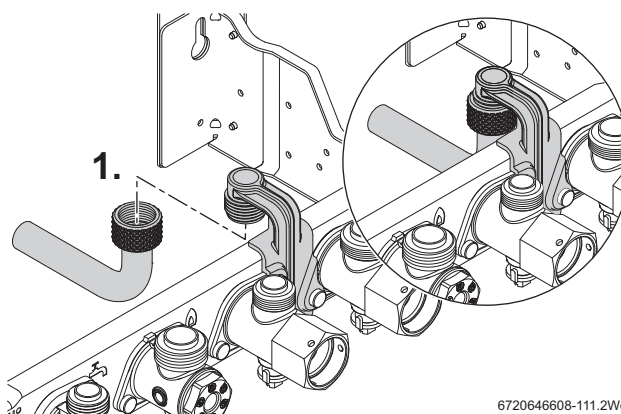

Fig. 29 PRV pipe connection

Once the wall frame has been mounted the PRV discharge pipe can be fitted.

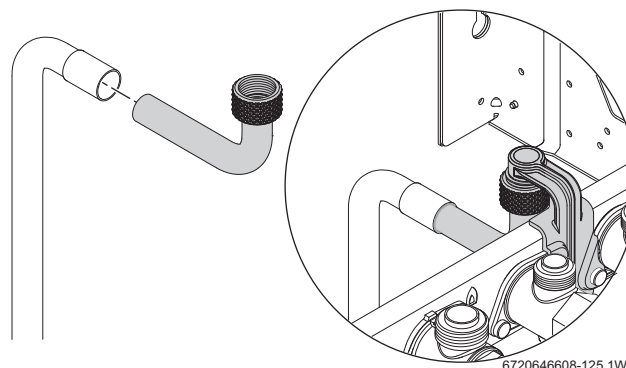

Fig. 30 PRV elbow fitting

- ▶ Connect the PRV discharge pipe to the pre-plumbing connector.
- ▶ The discharge pipe can be routed as described in section 4.5.
- ▶ The pre-plumbing connector must be removed before the boiler is hung on the wall frame.

5.5 HANGING THE BOILER

CAUTION: Lifting the boiler

- ▶ There are two handling holes incorporated into the inner casing left and right in the lower section of the appliance.
- ▶ Do not lift the boiler using the control panel as a hand hold.

NOTICE: Before hanging the boiler

- ▶ Remove the plastic strip fitted to pipes.
- ▶ Release the wire retaining clip for the expansion vessel connection on the pump manifold. Please protect the floor from residual water.

i The expansion vessel is secured to a bracket on the wall frame in a "Pre-Installation" position.

i Ensure that the control panel is in the closed position before hanging the boiler. There is no requirement to re-fit the bottom screws at this time.

- ▶ Stand the boiler upright to gain access to the rear of the hydraulic manifold.
 - ▶ Release the wire retaining clip securing the orange plastic blanking plug.
1. Remove the blanking plug from the expansion vessel connection at the hydraulic manifold before hanging the boiler.
- ▶ Ensure that the wire retaining clip is still fully released so that the expansion vessel pipe connection can be made into the hydraulic manifold.

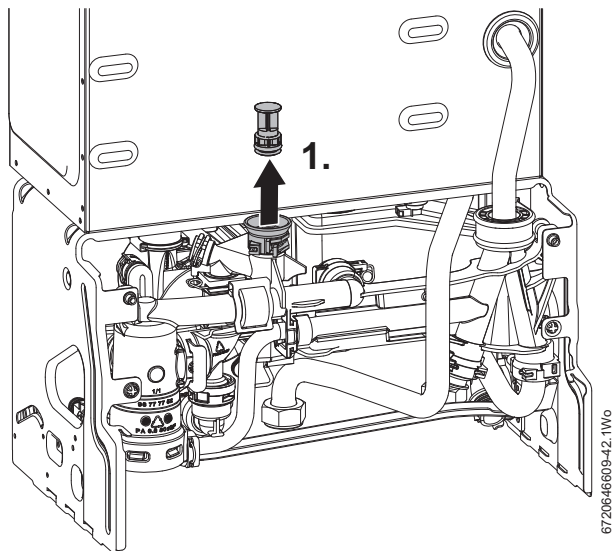

Fig. 31 Removing the blanking plug

1. Ensure that the plastic protection cap, refer to figure 31, is removed from the expansion vessel connection pipe.
- ▶ The boiler is mounted on the wall frame utilising the two mounting points, refer to figure 32, left and right at the top of the wall frame.

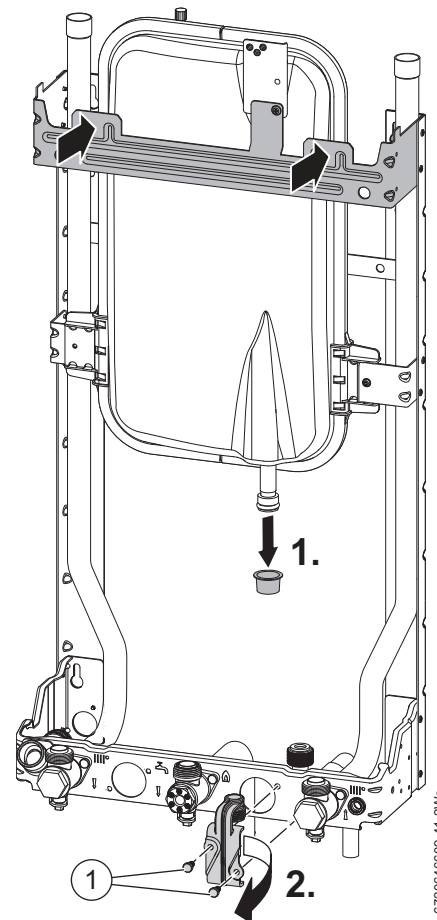

Fig. 32 Mounting points

- ▶ Hang the boiler on to the wall mounting frame by the two brackets positioned left and right at the top rear of the appliance. The expansion vessel is shown removed for clarity.

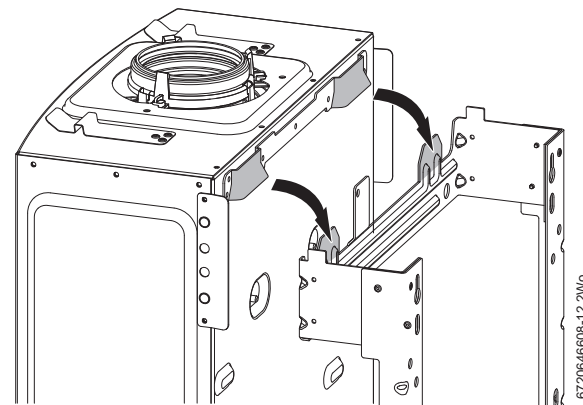

Fig. 33 Hanging the boiler

WARNING: Bonded washer (gas)

- ▶ The bonded washer must be used on the gas pipe isolating valve connection.

- ▶ Ensure that the gas and water connections to the isolating valves are made using the washers supplied in the Literature/Hardware pack. Tighten the gas and water connections firmly.
- ▶ Connect the PRV discharge pipe on the hydraulic unit onto the PRV outlet pipework, and hand tighten.

CONNECTING THE EXPANSION VESSEL

To connect the expansion vessel to the hydraulic pump manifold situated to the left of the pump:

1. Release the expansion vessel from the retaining bracket, see fig 34.
2. Ensure that the wire retaining clip on the pump manifold is fully withdrawn, but do not remove, before inserting the expansion vessel pipe into pump manifold, see fig. 34.
3. Secure in place with the wire retaining clip.

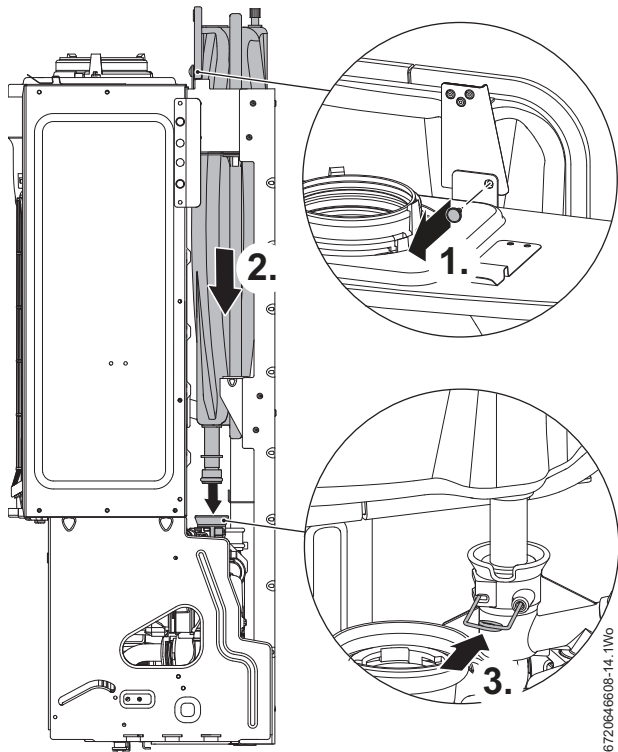

Fig. 34 Expansion vessel connection

6720646608-14.1Wo

CONNECTING THE SIPHON OUTLET

1. Push the black rubber siphon discharge hose onto the wall frame connector until fully engaged.

FILLING THE SIPHON

2. Pour 200 to 250 millilitres of clean water through the inner flue opening to fill the siphon before running the boiler.

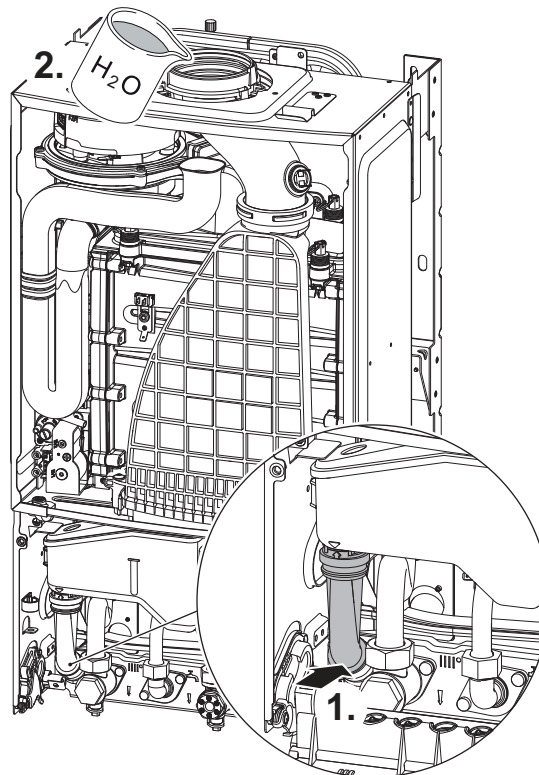

Fig. 35 Siphon fill

6720646608-121.3Wo

5.6 Flue turret/adaptor installation

The flue turret/adaptor for the appliance is secured using three retaining screws (figure 36, item [1]) which come in position on the appliance.



To ease assembly of flue components, apply silicone lubricant to sealing surfaces.

Refer to the manual supplied with the flue kit for complete installation instructions.

For plume management effective lengths and the effective flue lengths, refer to details in section 4.9.

Refer to figures 36 & 37.

- ▶ Remove the three inner flue tube retaining screws [1]. The inner tube will be held in place in the appliance.

- ▶ Check the appliance flue seal [2] is correctly seated and apply silicone grease.

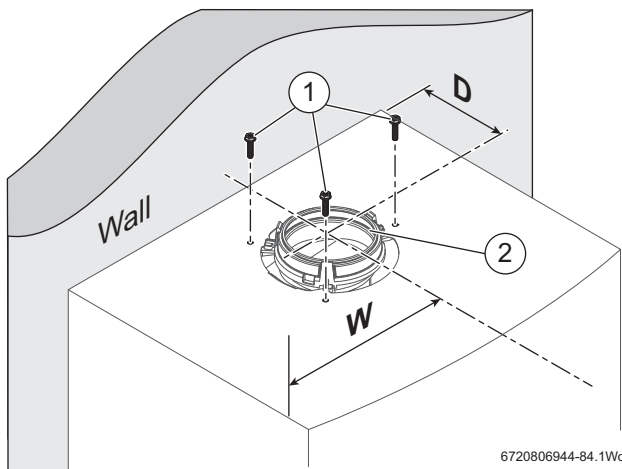

Fig. 36 Flue turret centre

[D] 180mm

[W] 195mm

- ▶ Align the flue turret/vertical adaptor to the appliance flue outlet with flat facing [3] to the rear of the appliance. The flue turret/adaptor should be pushed straight down, on to the appliance.
- ▶ The three inner flue tube retaining screws [1] are, re-used for the flue turret and replacement retaining screws [4] supplied with the adaptor kit are used to secure turret/adaptor to the appliance.

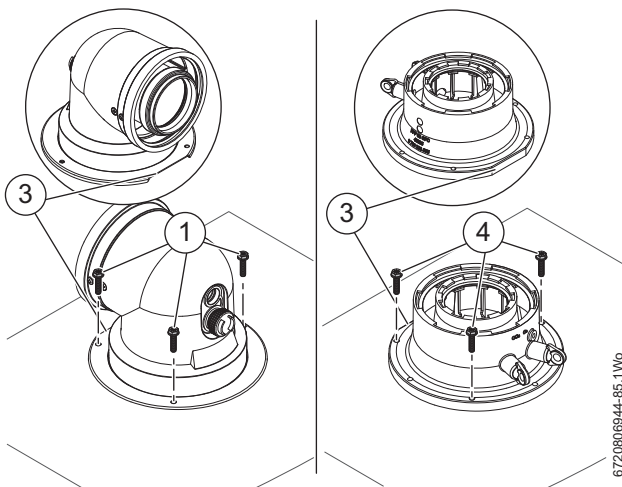

Fig. 37 Flue turret/adaptor connection

Additional notes and reminders:

- Ensure that all cut lengths are square and free from burrs.
- Ensure that the flue and seals are not damaged.
- The flue is sealed when assembled correctly, the components are pushed fully home and secured.
- The flue is set at an angle of 3° or 52mm per metre length.
- Support the flue at approximately one metre intervals and at a change of direction, use suitable brackets and fittings (flue bracket 100mm part number: 7 716 191 177, flue brackets 100mm x 6 part number: 7 716 191 178, flue bracket 125mm part number: 7 716 191 179)

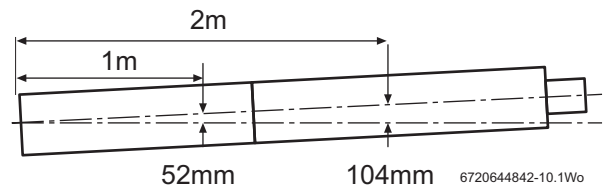

Fig. 38 Slope for condensate disposal

5.7 ELECTRICAL



CAUTION: Isolate the mains electrical supply before starting any work and observe all relevant safety precautions.



Additional equipment requiring 230V must be connected to the boiler's electrical supply.



The boiler is pre-fitted with a mains supply cable. External fuse rating - 3 Amps

- The mains electrical supply to the boiler must be through either a fused double pole isolator or a fused three pin plug and unswitched socket, situated, where practicable, adjacent to the boiler.
- The isolator must have a contact separation of 3mm minimum in both poles.

ACCESS TO ELECTRICAL CONNECTIONS:

- ▶ Access to all wiring connections are via the Installer access cover at the bottom front of the control panel. No access is required to other parts of the control board.
1. Refer to figure 39 and release the captive screws securing the Installer access cover.
 2. Remove the Installer access cover.

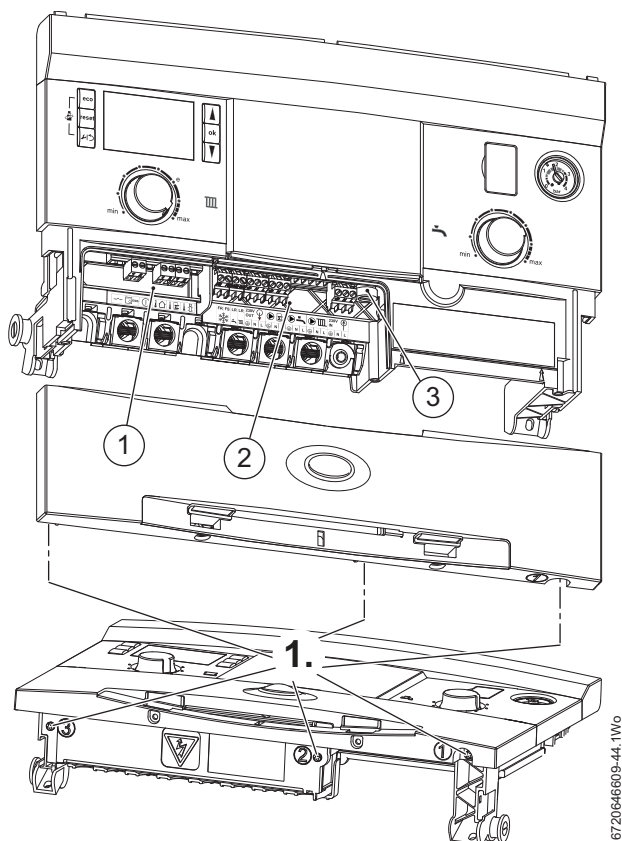

Fig. 39 Removing the installer access cover

1	Low voltage connections
2	Mains voltage connections
3	Fuse carrier - 5A

Low voltage connections

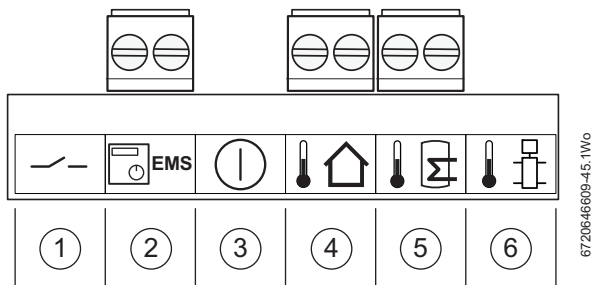

Fig. 40 Low voltage connectors

Low voltage terminal strip	
1	Low voltage room thermostat input (Not used)
2	EMS bus connections
3	External cut off switch (Not used)
4	Outdoor compensation sensor
5	Cylinder sensor
6	Low Loss Header sensor (Not used)

Table 21 Key to figure 40

Mains voltage connections

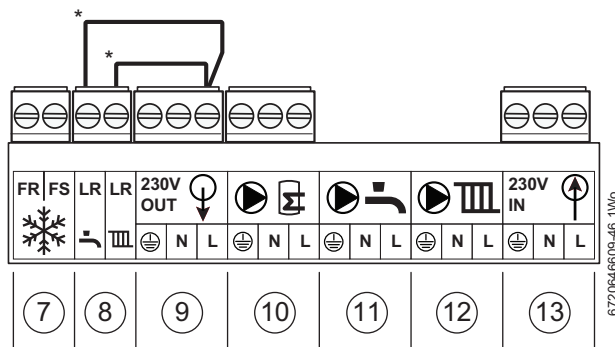

Fig. 41 Mains voltage connectors

Mains voltage terminal strip	
7	External frost thermostat
8	230 V A.C. switched live inputs <ul style="list-style-type: none"> • CH - External controls switch live connection point. • DHW - Inactive unless optional integral diverter valve fitted.
9	230 V A.C. mains output to wiring centre
10	Cylinder safety valve (G3)
11	DHW circulation pump (Not used)
12	Central heating circulation pump (Not used)
13	Boiler 230 V A.C. mains supply
*	Pre-wired links

Table 22 Key to figure 41

NOTICE: DHW LR (Live Return) switched live - with optional integral diverter valve only.

► This input provides connection for a proprietary external twin channel time control for the DHW cylinder, (link must be removed). If an external twin channel control is not fitted, the link must be in place to ensure a cylinder demand. All Worcester twin channel digital controls provide this functionality.

5.7.1 MOUNTING OPTIONAL PLUG-IN CONTROLS - WHEN OPTIONAL INTEGRAL DIVERTER VALVE IS FITTED

i The optional integral diverter valve kit allows for the Worcester plug-in controls options to be used.

CAUTION:

► Isolate the mains electrical supply before starting any work and observe all relevant safety precautions.

i Refer to the Programmer/Timer manual for set up and operation of the unit.

► When connecting Worcester plug-in or EMS intelligent controls, the links (→ items 8 & 9 in figure 41) must be left in the connection points.

REMOVING THE BLANKING PLATE

The control panel must be released and swung forward slightly to gain access to the top cover panel, refer to section 7.4 for access to the control panel.

1. Release the captive screws securing the top cover panel.
2. Remove the cover panel to enable the blanking plate to be removed.
3. Release the three captive screws enough to allow the Installer access cover to be lowered by 10mm.
4. Lower the Installer access cover to allow the blanking panel to be removed.
5. Use the tab (1) to lift and also press up on the bottom edge of the blanking plate to release the clips from the slots in the control panel.
6. Pull the blanking plate forward to remove.

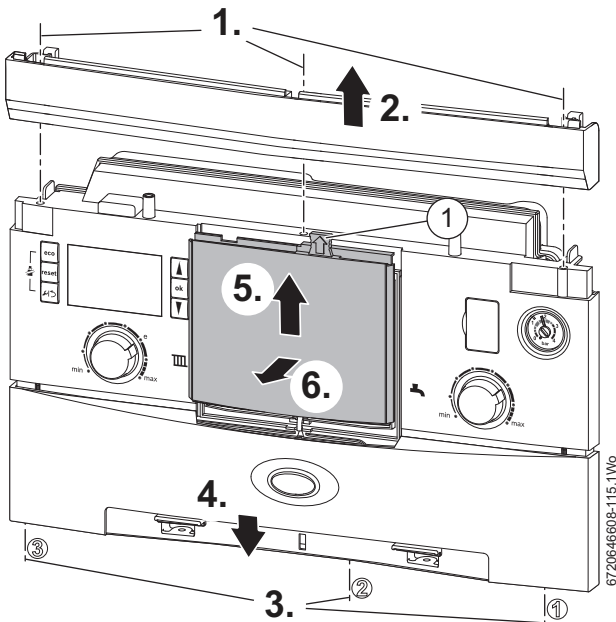

Fig. 42 Removing the blanking plate

FITTING THE PROGRAMMER/TIMER



When fitting EMS intelligent programmers, step 1 can be ignored.

1. Connect the ribbon cable to the socket (2) in the control panel, ensuring that the cable will fit into the recess (3) in the control panel.
2. Align the clips on the back of the Programmer/Timer with the slots in the control panel.

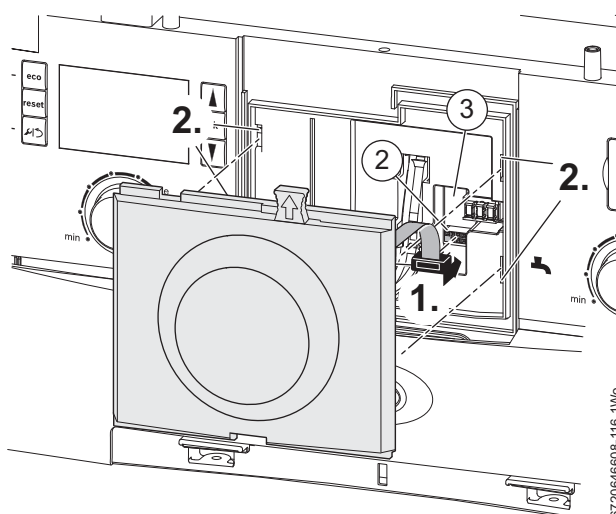

Fig. 43 Connecting the Programmer/Timer

3. Push the Programmer/Timer in to engage with the slots in the control panel.
 4. Pull the Programmer/Timer down to secure with the clips.
 5. Slide the Installer access cover up into position.
 6. Secure with the three captive screws.
 7. Replace the top cover panel.
 8. Secure in position with the captive screws.
- Re-secure the control panel.

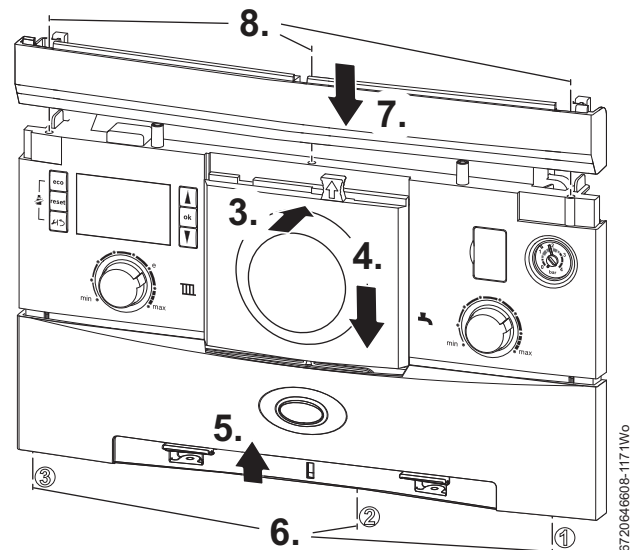

Fig. 44 Fitting the Programmer/Timer

Part number	Description
7 716 192 038	DT20 twin channel digital timer (preheat time control available)
7 716 192 054	DT20RF digital RF thermostat with twin channel programmer (preheat time control available)
7 716 192 052	DT10RF digistat (preheat time control available)
7 716 192 053	DT10RF optimiser (preheat time control available)
7 716 192 065	FR10 intelligent room thermostat
7 716 192 066	FR110 programmable room thermostat (preheat time control available)
7 716 192 067	FW100 weather compensation controller (preheat time control available)
7 733 600 001	Comfort I RF (RF thermostat with twin channel programmer, preheat time control available)
7 733 600 002	Comfort II RF (programmable room thermostat, preheat time control available)
7 733 600 003	Comfort (twin channel programmer)
7 733 600 039	Comfort wall plate kit
7 738 110 058	Sense I intelligent room thermostat
7 738 111 064	Sense II weather compensation controller (preheat time control available)
7 716 192 072	Worcester Wave (thermostat)

Table 23 Control accessories

INSTALLATION

NEW COMPLETE SYSTEM INSTALLATIONS

If a new complete heating system is installed in a new build property or it is a first time installation in an existing property, the heating systems must conform to current building regulations Part L1a.

The exception to this are single storey, open plan dwellings where the living area is more than 70% of the total usable floor area. Then this type of dwelling can be controlled as one zone.

An alternative would be individual electronically controlled TRVs.

For dwellings with a floor area over 150m², separate time and temperature control for each zone is required. All radiators must have TRVs fitted in all rooms except bathrooms and rooms with thermostats.

EXTERNAL 230V PROGRAMMER AND TWO HEAT ZONES WITH VENTED CYLINDER (S-PLAN PLUS)

(For dwellings of less than 150m²)

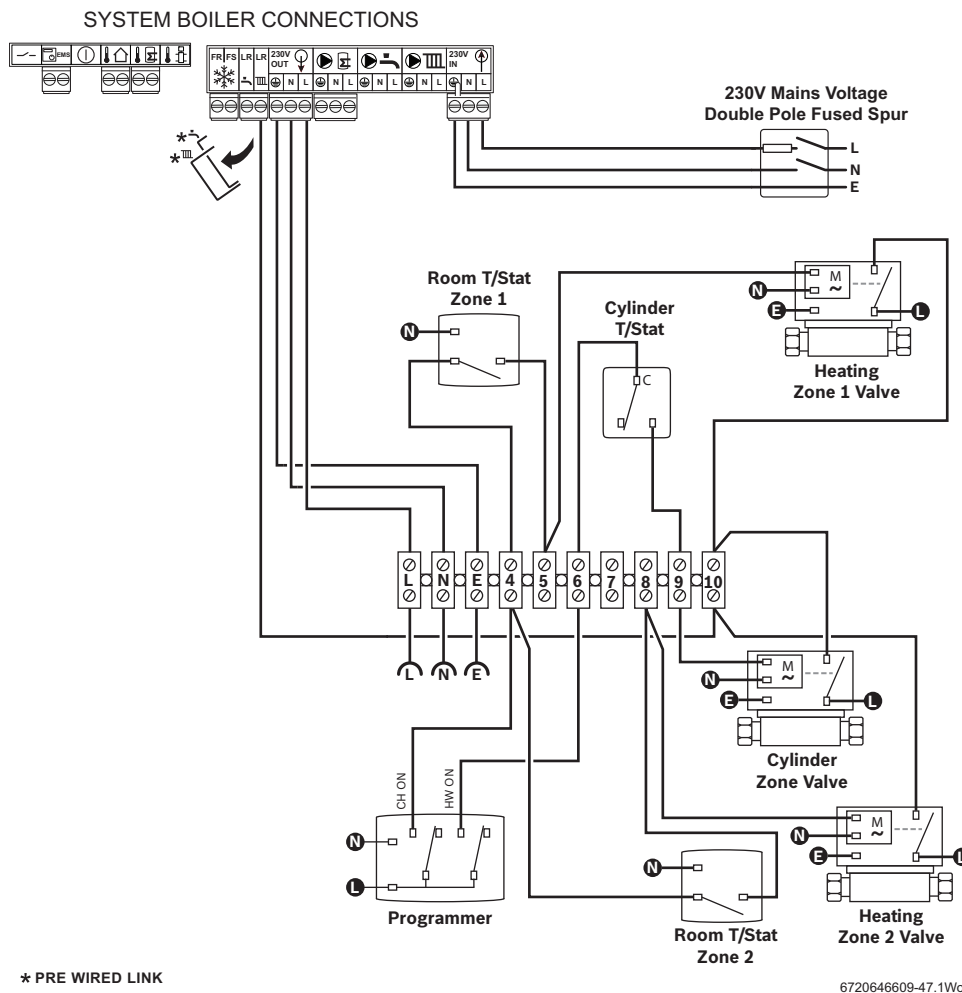
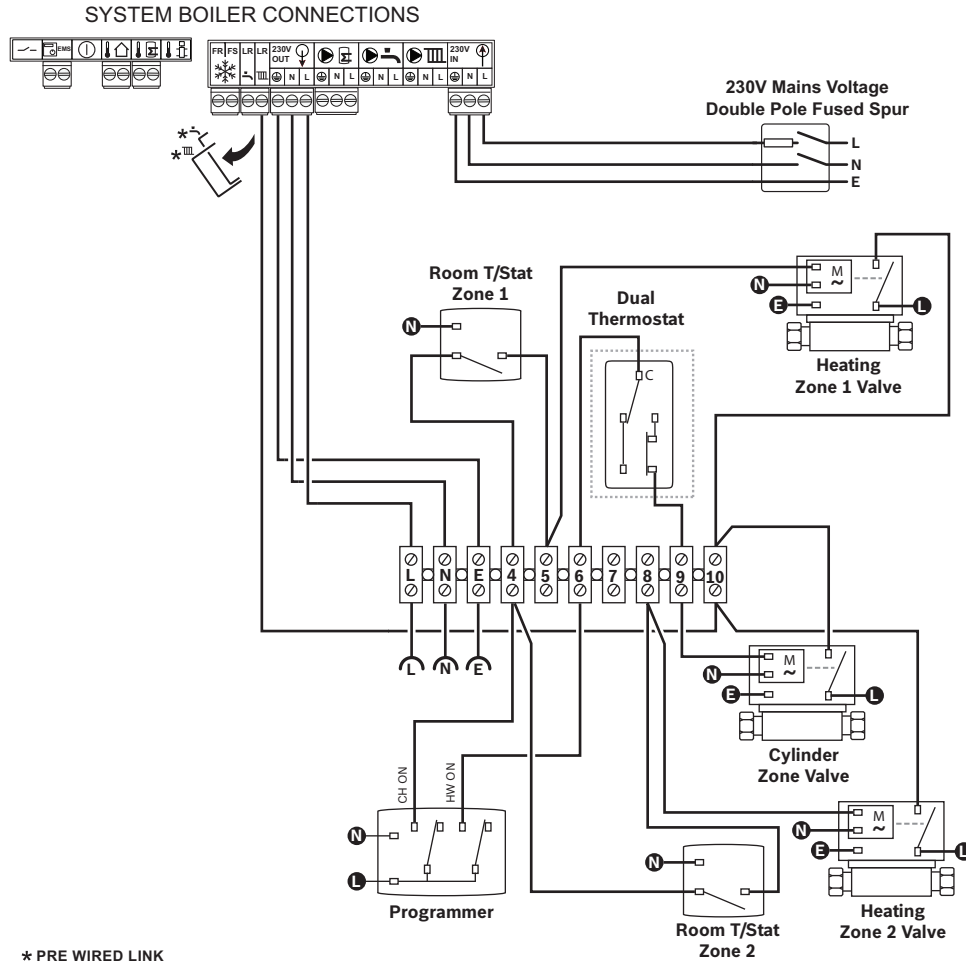

Fig. 45 External controls with vented cylinder

	All of these points are wired to		this point
	All of these points are wired to		this point
	All of these points are wired to		this point

Table 24 Connection legend

EXTERNAL 230V PROGRAMMER AND TWO HEAT ZONES WITH UNVENTED CYLINDER (S-PLAN PLUS)



6720646609-48.1W0

Fig. 46 External controls with unvented cylinder

	All of these points are wired to		this point
	All of these points are wired to		this point
	All of these points are wired to		this point

Table 25 Connection legend

EXISTING INSTALLATIONS

For boiler replacements on an existing system, it is not necessary to zone the upstairs and downstairs separately, compliance with the zone requirements can be achieved by a single room thermostat or programmable room thermostat.

While the system is drained down, a TRV must be fitted to all radiators except in bathrooms and the room with the thermostat.

SYSTEM WIRING CENTRE

External components are connected to the Wiring centre junction box.



Remove any links from the boiler terminal block.

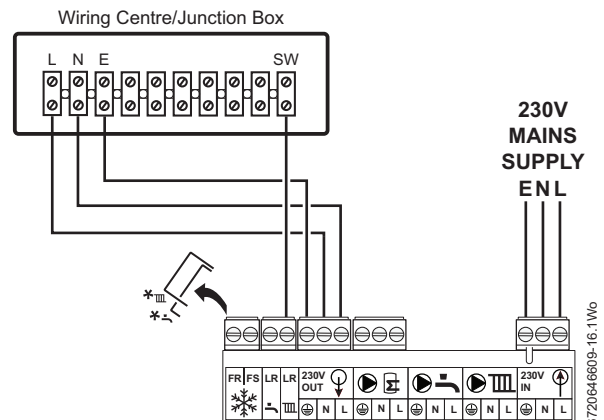

Fig. 47

NOTICE:

- ▶ External diverter valve(s) and all other 230V parts are not supplied with the boiler.
- ▶ Refer to the manufacturer's instructions when connecting external parts to the wiring centre.
- ▶ Worcester, Bosch Group cannot be held responsible for wiring errors.
- ▶ A fascia mounted digital programmer/timer cannot be fitted unless the optional integral diverter valve is installed.
- ▶ There is an option to fit an internal diverter valve. This also requires fitting an extra connector and a code plug change. See "Optional Diverter Valve". Mechanical and wiring instructions supplied with integral diverter valve kit.
- ▶ Optional Integral Diverter Valve kit:
27kW - 7 716 192 758
30kW - 7 716 192 759

OPTIONAL EXTERNAL FROST STAT CONNECTION FOR PROTECTION OF SYSTEM PIPEWORK IN UNHEATED AIR SPACE

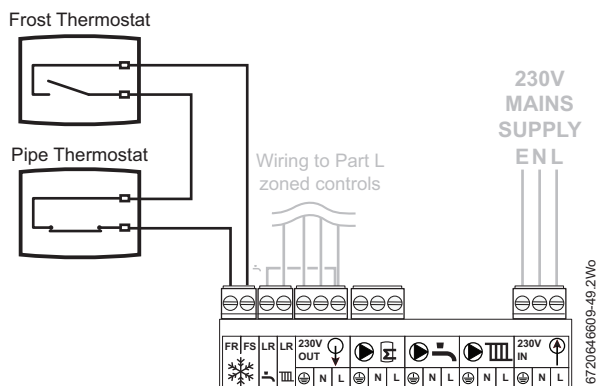

Fig. 48 Frost Thermostat

- ▶ Connect frost thermostat cables to terminals F_S & F_R.
- ▶ These connections are not polarity sensitive.
- ▶ The external frost thermostat operates the pump, and may start the burner.

6 COMMISSIONING

6.1 PRE-COMMISSIONING CHECKS

CAUTION: MAINS SUPPLY

- ▶ Isolate the mains electricity supply before starting any work and observe all relevant safety precautions.

Check that the service and water pipes are connected to the correct positions on the manifold.

Ensure that the washers have been fitted to the water connections and the bonded washer to the gas connection on the manifold, refer to Fig. 27.

1. - CH Flow (22mm)
2. - Gas inlet (22mm)
3. - CH Return (22mm)

- ▶ Check the gas type specified on the data label, on the right hand side of the combustion chamber, matches that of the gas supply.
- ▶ Turn on the main gas supply, carry out a tightness test on the gas pipework and connections with the boiler gas isolating pipe valve open. Rectify any leaks.
- ▶ Check that the condensate pipe has been connected and correctly fitted to the siphon.

- ▶ Check pressure relief drain pipe is correctly fitted and securely hand tightened.

NOTICE: If the boiler is not to be commissioned immediately then, after successfully completing all of the checks and any rectification work:

- ▶ Close the gas valve
- ▶ Close the water shut off valve
- ▶ Isolate the gas supply
- ▶ Isolate the electricity supply
- ▶ Label appropriately

6.2 FILLING THE SYSTEM

1. Turn on the water main and open the system valves.
2. Open all radiator valves.
3. Fill the system via a WRAS approved filling loop to 1 bar then turn close the filling loop valve.
4. The Automatic Air Vent will release any air trapped in the boiler.
5. Manually vent all radiators, tighten when completed and check the system and correct any leaks.
- ▶ The boiler integral expansion vessel is pre-charged to 0.75 bar (equal to a static head of 7.5m (22ft). A Schraeder type valve is fitted to the expansion vessel to allow for pressure adjustment if required.
- ▶ If an extra expansion vessel is fitted to the central heating return, adjust this to the same pressure as the appliance's internal expansion vessel, refer to separate instructions with the extra expansion vessel.
6. If required increase system pressure back to 1 bar.
7. Isolate and remove filling loop connection to system.

6.3 WATER TREATMENT

NOTICE:

- ▶ Artificially softened water must not be used to fill the central heating system.

ENSURE THAT THE SYSTEM HAS BEEN CLEANED. REFER TO SECTION 4.1 OF THESE INSTRUCTIONS.

FLUSHING (Central Heating):

- ▶ Ensure the boiler is switched off.
- ▶ Open all drain cocks and drain the system while the boiler is hot.
- ▶ Close drain cocks and add a suitable flushing agent at the correct strength for the system condition in accordance with the manufacturer's instructions.
- ▶ Run the boiler/system at normal operating temperature for the time stated by the manufacturer of the flushing agent.
- ▶ Drain and thoroughly flush the system to remove the flushing agent and debris.

INHIBITOR (Central Heating):

- ▶ Check the drain cocks are closed and all the radiator valves are open before adding a suitable inhibitor compatible with aluminium (or combined inhibitor/anti-freeze if the system is exposed to freezing conditions) to the heating system water in accordance with the manufacturers instructions.

i The pH value of the system water must be less than 8 or the appliance guarantee will be invalidated.

- ▶ Fill the system via a WRAS approved filling loop to between 1 and 1.5 bar.
- ▶ Vent all the radiators; tighten vents when complete.
- ▶ Re-pressurise if necessary to 1bar.
- ▶ Set all controls to maximum.
- ▶ Record the date when the inhibitor was added to the system on the Benchmark checklist.

NOTICE:

- ▶ The concentration of inhibitor in the system should be checked every 12 months or sooner if system content is lost.
- ▶ The addition of sealing agents to the system water is not recommended as this can cause problems with deposits left in the heat exchanger.

WATER TREATMENT

Suitable water treatment products can be obtained from the following manufacturers:

FERNOX	0870 601 5000 - www.fernox.com
SENTINEL	0800 389 4670 - www.sentinel-solutions.net

6.4 STARTING THE APPLIANCE

CAUTION: RUNNING THE APPLIANCE

- ▶ Never run the appliance when the appliance/system is empty or partially filled.

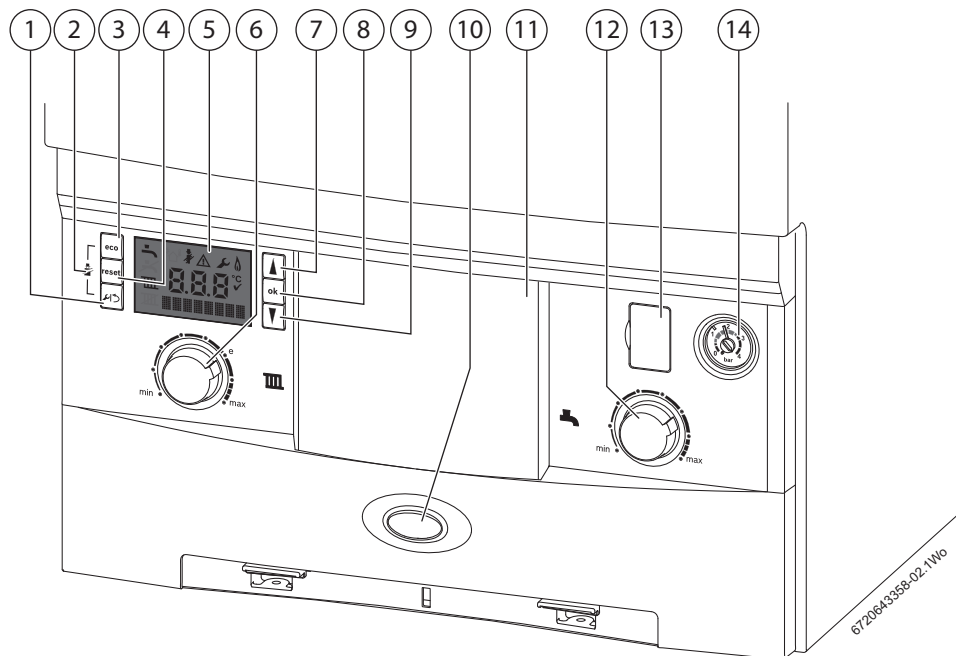

Fig. 49 Control panel

Key to figure 49	
1	Spanner/return button
2	Service engineer symbol
3*	Eco button*
4	Reset button
5	Boiler display
6	Central heating temperature control
7	Scroll up button
8	OK - Select/confirmation button
9	Scroll down button
10	Operation and fault indicator (blue)
11	Position for optional programmer
12*	Hot water temperature control*
13	Diagnostic port (Worcester engineers only)
14	System pressure gauge
*	Only operational when the optional integral diverter valve is fitted. See page 11 for more information on the DHW control.

Switching the appliance on/off:

- ▶ Turn on the mains power supply, initially the “Boiler start up screens” will be displayed (refer to figure 50).
- ▶ Turn on any external controls
- ▶ Set the thermostatic radiator controls to maximum temperature
- ▶ Set the digital clock/programmer to continuously ON and the room thermostat to maximum temperature

Turn the boiler CH temperature control (6) to maximum. The “burner on” flame symbol will be shown on the boiler display.

If the boiler fails to light, a flashing fault code will be displayed.

NOTICE: RESET

- ▶ Do not press the blue operation/fault diagnostic indicator (10) to reset the boiler.

To reset the boiler, press the reset button (4), the tick symbol will be displayed briefly for a successful reset.

COMMISSIONING

6.4.1 BOILER START UP SCREENS

On initial start up, the following screens are displayed:

1. All the symbols are displayed for approximately two seconds.
2. The control will run an internal test.
3. When the internal test has been successfully performed, this screen is displayed:
 - The boiler is in stand-by.
 - The flow temperature sensor indicates the primary temperature from the heat exchanger (not the target set point).

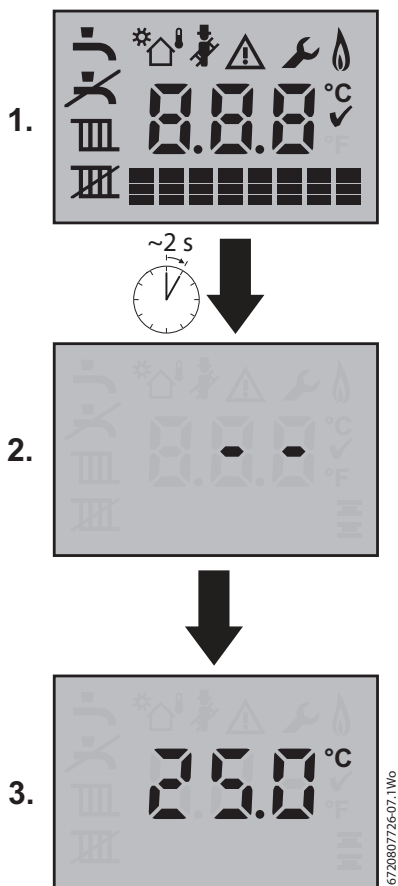

Fig. 50 Boiler start up screen

- ▶ If no adjustments are made for 30 seconds the back light is turned off.
- ▶ As soon as an adjustment is made, the screen will light up and the relevant information will be displayed.
- ▶ If the Eco button  is pressed or the Hot water temperature control is adjusted the boiler display will show N/A to indicate that these functions are not available without the optional integral diverter valve.



Fig. 51









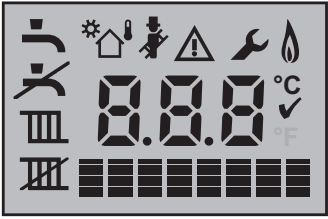

SCREEN DISPLAY	DESCRIPTION
All possible screen symbols 	This screen is displayed briefly during boiler start up and shows all the symbols that could be displayed.
Alpha/Numerical display 	Displays a temperature or boiler status code.
Text display 	Displays PreHeat or Eco, or diagnostic code
Hot water 	Displays this symbol during a DHW demand.
Central Heating 	Displays this symbol during a CH demand.
Chimney sweep mode 	Displays during service when the boiler is set to maximum or minimum output.
Alert 	Displays with the boiler status code and diagnostic code during a fault condition.
Service mode 	Displays when a qualified service engineer is in the service menus.
Burner on 	The boiler is in operation and the flame is alight.
Centigrade °C	Displays next to the temperature reading.
Confirmation ✓	This symbol confirms a manual change.

Table 26 Symbol description

STATUS CODES

Refer to section 8.5 for Status codes and service menus.

These are not faults, but provide information concerning the current status of the boiler.

During normal boiler operation various Status codes can be displayed by pressing the  button.

The first screen of the Information menu displays the current Status code, this will change as the boiler runs through various modes and sequences.

6.5 COMMISSIONING



If the optional integral diverter valve is fitted (not supplied) and the Service mode and maximum output are selected the boiler will operate both the Central Heating and DHW circuits with the diverter valve in the mid position. This is to allow sufficient time for the setting procedure.

When the water temperature reaches 75°C the diverter valve will switch to CH only.

For S and Y plan systems only use the Central Heating circuit.

6.5.1 CHECKING THE GAS INLET PRESSURE

The inlet pressure to the appliance must be checked using the following procedure:

MEASURING THE INLET PRESSURE

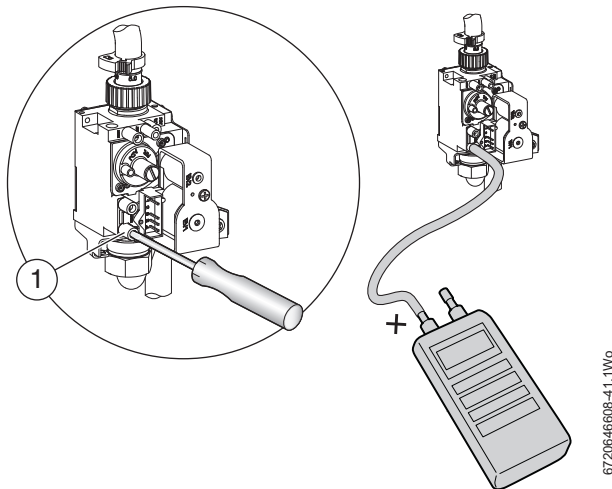

Fig. 52 Inlet pressure test point

- ▶ Close gas isolation valve.
- ▶ At the inlet test point (1), slacken the screw for a maximum of half a turn and connect a manometer.
- ▶ Open gas isolation valve.
- ▶ Measure the pressure with the boiler running at maximum.
 - Press the **eco** and **▶** button for more than five seconds and the boiler will ramp up to maximum output in approximately 30 to 35 seconds.
 - The display will show the chimney sweep symbol and the word **MAX**.

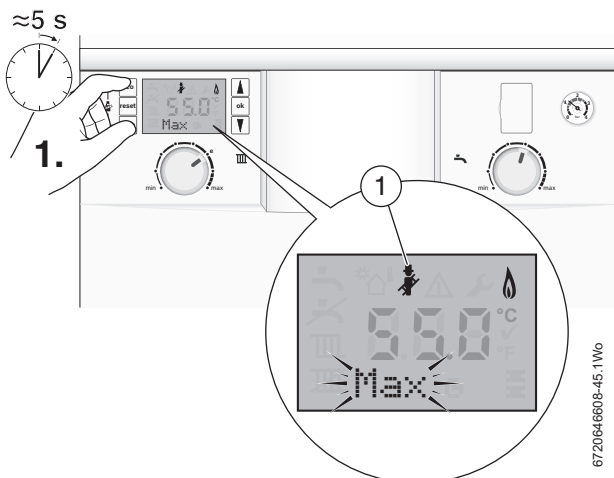

Fig. 53 Setting boiler to maximum

- ▶ Check the gas supply working pressure at the gas valve conforms to values shown in Fig. 54 or Fig. 55.

- ▶ Press the **▶** button to return to normal operation.
- ▶ The boiler will run for 15 minutes in service mode and return to normal if no other inputs are made.

After the tests are completed:

- ▶ Disconnect the manometer.
- ▶ Re-tighten, but do not overtighten the inlet pressure test point screw. Check for gas tightness

GAS PRESSURE WITHIN THE SYSTEM

Refer to the figures below for natural gas or L.P.G gas pressures.

The working pressure at the boiler must not be less than the working pressure read at the meter minus 1mbar for natural gas or minus 2.5mbar for L.P.G.

The pressure drop from the meter to the gas valve must not be more than 2.5mbar for natural gas or 4mbar for L.P.G.

If the pressure drop is greater than shown below, then this would indicate a problem with the supply pipework which must be rectified.

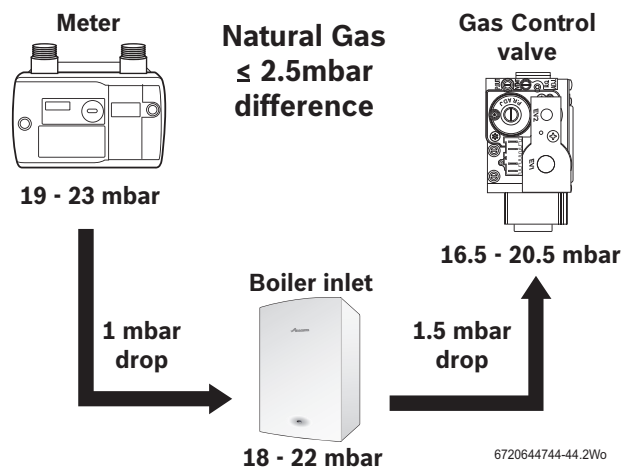

Fig. 54 Natural gas pressures

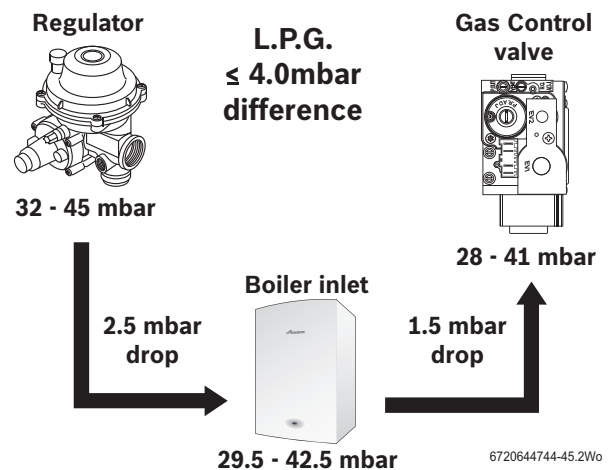

Fig. 55 L.P.G. pressures



NOTICE:



Do not continue commissioning until the correct gas pressure is achieved.

6.5.2 CHECKING THE GAS RATE

- ▶ The gas rate should be measured at the gas meter after the boiler has been operating for a minimum of 10 minutes at maximum output.
- ▶ See Technical data section on page 8 of this manual for gas rates and CO/CO₂ ratios.
- ▶ Where a gas meter is not available (e.g. L.P.G.) the CO/CO₂ must be checked.

6.5.3 GAS RATING TEST

- ▶ Ensure all other gas appliances are isolated.

1. Set the boiler to maximum output by pressing  and the  buttons together for at least 5 seconds.

The chimney sweep symbol (1) will be displayed at the top of the screen and the word “Max” will flash at the bottom of the screen. The boiler will ramp up to maximum output in 30 to 35 seconds.

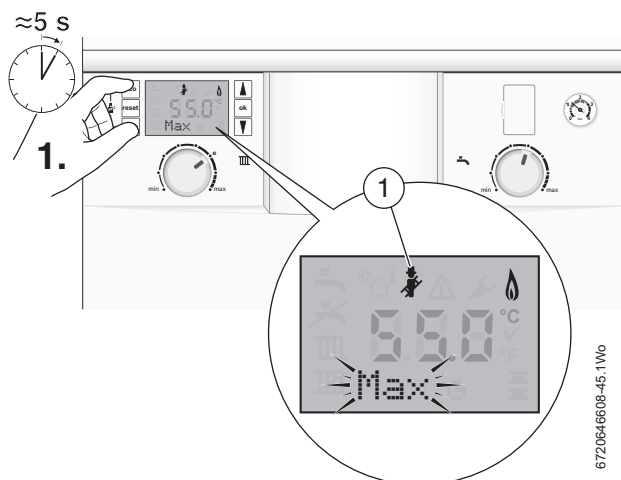



Fig. 56 Setting boiler to maximum

- ▶ Ensure that the boiler has stabilised at maximum output.
- ▶ Carry out Gas rating procedures as described in “Essential Gas Safety” third edition.
- ▶ If pressure and gas rate are satisfactory press the  button again and the boiler will return to normal operation.
 - If left in the service mode the control will return to normal operation after 15 minutes.

6.5.4 CHECKING FOR LEAKS DURING OPERATION

- ▶ Use an approved leak detector to check all connections for possible leaks. The product must be certified as a gas leak testing agent.
- ▶ Do not allow the product to come into contact with the electrical wiring.

6.6 DOMESTIC HOT WATER
Controlling the hot water temperature:

	NOTICE: Domestic Hot Water ▶ The hot water temperature can only be controlled when the “Optional diverter valve” kit is fitted.
---	---

The hot water temperature can be set to between approximately 40°C and 70°C using the DHW temperature control.

6.7 CO and Combustion checks

The following combustion and flue integrity checks are mandatory from April 2014 and these values must be recorded on the Benchmark check list, at the back of this manual.

Once the gas rate and pressure have been confirmed as acceptable then the CO and combustion checks can be undertaken.

The flow chart is given for guidance, the details of the checks are given in the following sections:

- Checking flue integrity, refer to section 7.3, page 42
- Flue gas analysis, refer to section 7.6, page 44



NOTICE: BEFORE CO AND COMBUSTION CHECKS:

- ▶ Refer to section 6.5.1 and 6.5.2 to verify gas type, gas inlet pressure, and gas rate. Visually check the integrity of the whole flue system and confirm that all the components are correctly assembled, fixed and supported.
- ▶ The flue gas analyser must be the correct type as specified in BS 7967. Before use the analyser must have been calibrated as specified by the manufacturer. The installer must be competent in the use of the analyser. Check and zero the analyser in fresh air as specified by the manufacturer.
- ▶ The gas valve is factory set and must not be adjusted during commissioning if found to be out of tolerance, please contact the Worcester, Bosch Group help line 0330 123 3366.

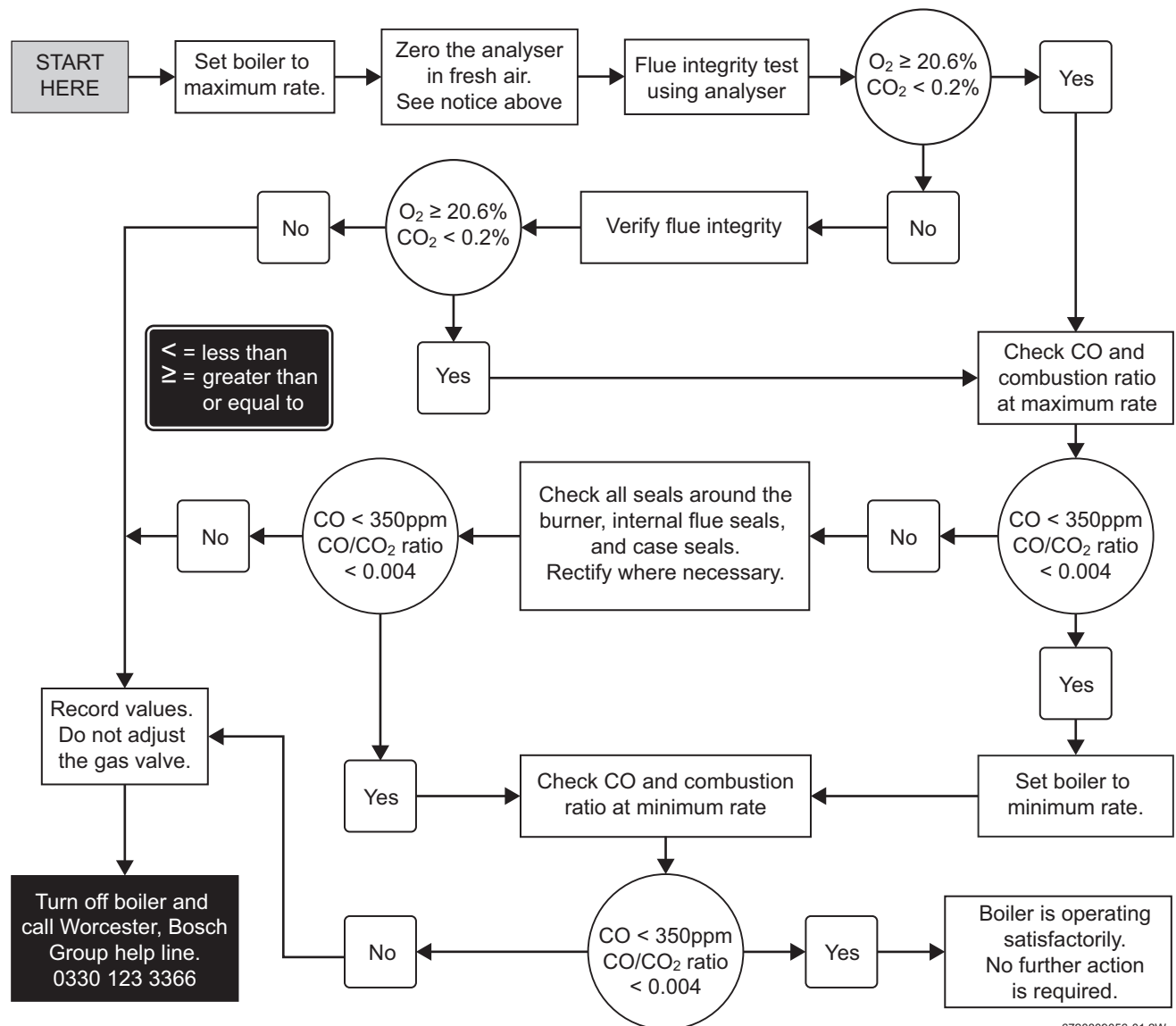

6720809056-01.2Wo

Fig. 57 Combustion check flow chart

6.8 FINISHING COMMISSIONING

6.8.1 REPLACING THE BOILER CASE

1. Ensure that bottom edge of the case is engaged onto the rail of the superstructure. Slide into place.
2. Ensure that the securing points on top of the case are properly located.
3. Tighten the bottom two screws.

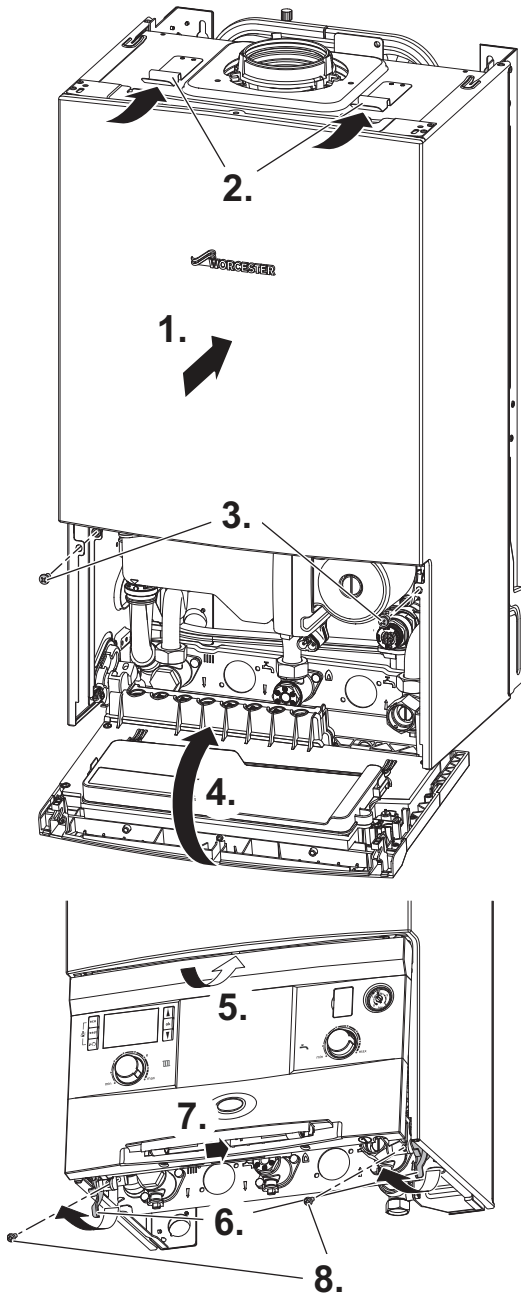

Fig. 58 Fitting case

6.8.2 SECURING THE CONTROL PANEL

4. Raise the control panel.
5. Push the control panel up to engage the top edge under the case.
6. Lift the catches with your fingers.
7. Press the bottom of the control panel back to engage with the catches
8. Secure the catch retaining screws underneath the boiler.

6.8.3 FITTING THE FASCIA FLAP

1. Rotate the hinge to be in-line with the flap and present the flap assembly up to the fascia.
2. Push the pegs on the hinge into the three slots in the front of the fascia and close the flap.
3. Secure the flap to the fascia with the two screws provided.

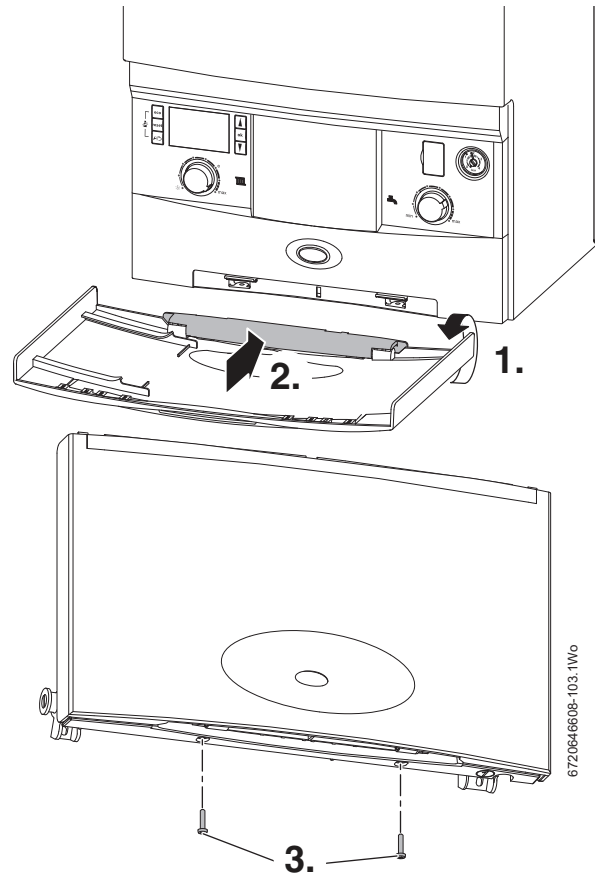

Fig. 59 Installing the fascia flap

6.8.4 INSTALLING THE BOTTOM PANEL

1. The bottom panel slides onto two ledges either side of the boiler frame.
2. Hold the panel up against the underside of the boiler and slide towards the rear, until there is no more movement.
3. Slide the panel forward until it is fully engaged.

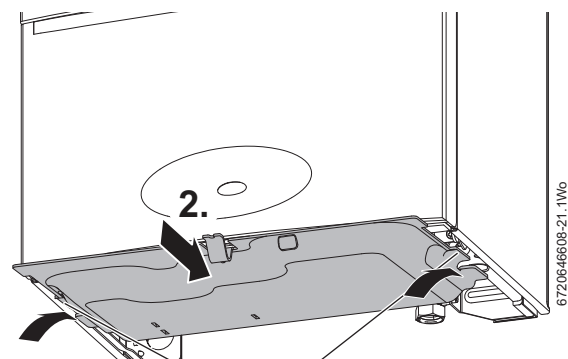

Fig. 60 Bottom panel installation

6.8.5 HANDOVER

- ▶ Complete the Benchmark Gas Boiler Commissioning Checklist.



The Benchmark Checklist can be found at the rear of these instructions.

- ▶ Open the fascia flap by hinging the flap downwards using the curved hand hold in the centre of the flap.
- ▶ Set up the controls and show the customer how to operate all the controls shown in the User Guide plus any external controls.
- ▶ Instruct the customer on:
 - the need to re-pressurise the boiler occasionally and the pressure expected at the pressure gauge.
 - location of the filling loop and system pressure gauge.
 - the use of the filling loop and how to re-pressurise the system.
 - how to use the TRVs.
 - how to reset the boiler.
- ▶ Show the customer the fault finding information in the User guide.
- ▶ Show the customer where the serial number/boiler information is when they call in with a problem (Benchmark checklist at the rear of the manual).
- ▶ Give the customer details of how to contact the installer/gas emergency numbers.
- ▶ Show the customer how to safely isolate the boiler
- ▶ Advise the customer where they can find information on the Worcester Bosch website.
- ▶ Advise the customer that the varying external temperatures will affect the output of the boiler.
- ▶ Ensure that the User Guide and Installation, Commissioning and Service manual, with the Benchmark checklist and service record, is left with the boiler or homeowner.
- ▶ If the appliance is unused and exposed to freezing conditions, shut off all the mains supplies and drain the system and boiler, label accordingly.

6.8.6 BOILER GUARANTEE

This boiler has a guarantee against faulty materials or workmanship for a period from the date of installation subject to the following terms and conditions:

- During the period of this guarantee any components of the boiler which are proven to be faulty or defective in manufacture will be exchanged or repaired free of charge by Bosch Thermotechnology Ltd.
- The householder may be asked to prove the date of installation, that the boiler was correctly commissioned and, where appropriate, the first year's service has been carried out to the satisfaction of Bosch Thermotechnology Ltd., when requested. These should be documented as a part of the Benchmark Checklist.
- The boiler has been used only for the normal domestic purposes for which it was designed.

This guarantee does not affect your statutory rights.

Guarantee registration

Your Greenstar appliance carries a guarantee against faulty material or manufacture subject to Terms and Conditions.

Guarantee Registration can be completed:

- On-line
 - You can register on our website:
www.worcester-bosch.co.uk/guarantee
- By phone
 - You can register by ringing 0330 123 2552
- By post
 - Please send your completed form to:
Worcester, Bosch Group, Cotswold Way, Warndon, Worcester, WR4 9SW.

To read the full Terms & Conditions please visit us on-line at www.worcester-bosch.co.uk/guarantee.

Your statutory rights are not affected by the manufacturer's guarantee.

7 SERVICE AND SPARES



CAUTION: Mains supplies

- ▶ Turn off the gas supply and isolate the electrical mains supply before starting any work on the appliance and observe all relevant safety precautions.



CAUTION: Component replacement:

- ▶ After replacement of a gas related component, where a gasket or seal has been disturbed or replaced, check for gas tightness using a gas sniffer/analyser.
- ▶ Also after re-assembly, carry out the following checks:
 - Fan pressure in section 7.5,
 - Flue gas analysis in section 7.6.



NOTICE: Service work

- ▶ Service work must be carried out by a competent engineer, such as British Gas or Gas Safe registered personnel!



NOTICE: FLUE GAS ANALYSER

- ▶ Service work must not be attempted if a flue gas analyser is not available.

- To ensure continued efficient operation the appliance must be checked at regular intervals.
- The frequency of servicing will depend upon the particular installation conditions and usage, however normally an annual service is recommended.
- The extent of the service work required by the appliance is determined by the operating condition of the appliance when tested by qualified engineers.
- After each service, the service interval record sheet at the rear of this manual, must be completed.

7.1 INSPECTION AND SERVICE

1. Check that the terminal and terminal guard, if fitted, are unobstructed and undamaged.
2. If the appliance is in a compartment or cupboard, check that the specified service space around the appliance is clear.
3. Check all joints and connections in the system and remake any that show signs of leakage.
Refill and re-pressurise if applicable as described in the commissioning section.
4. Operate the appliance and take note of any irregularities.
Refer to the fault finding pages for rectification procedure.

7.2 CHECKING THE GAS INLET PRESSURE

NOTICE:
 Do not continue with the other checks if the correct gas pressure can not be achieved.

► Check that the gas working pressures in the system conform to the figures shown below:

meter/ regulator	Allowed mbar pressure drop			
	across pipework	boiler inlet	across boiler	gas control valve
Natural gas				
19 - 23	1	18 - 22	1.5	16.5 - 20.5
L.P.G.				
32 - 45	2.5	29.5 - 42.5	1.5	28 - 41
mbar range				

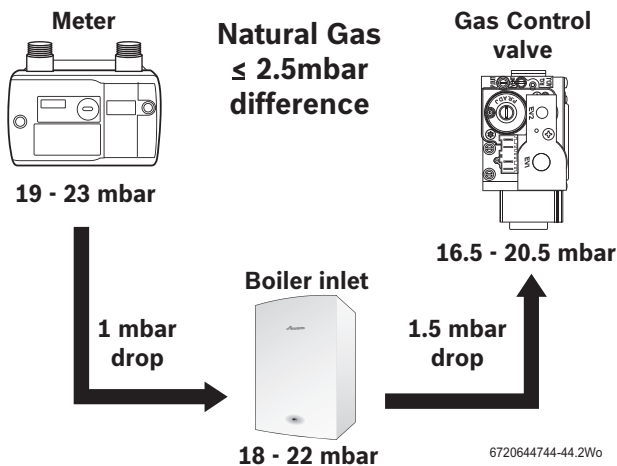

Fig. 61 Natural gas pressure

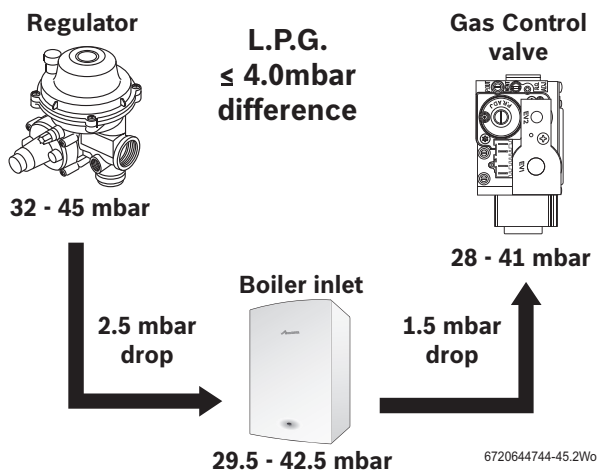

Fig. 62 L.P.G. pressure

7.3 CHECKING FLUE INTEGRITY

The integrity of the flue system and performance of the boiler can be checked via the flue turret sample points.

Flue gas sample point	1
Air inlet sample point	2

Table 27 Key to figure 63

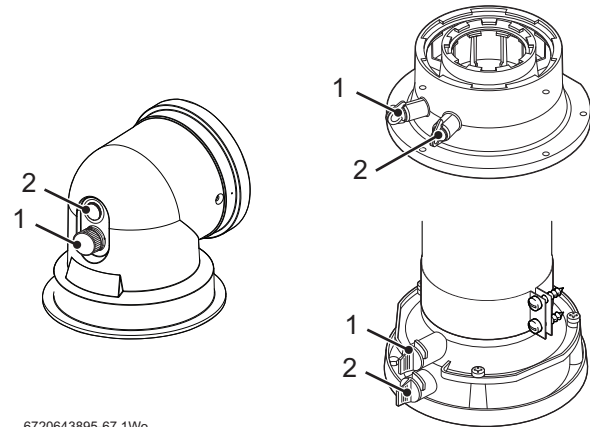

Fig. 63 Flue turret test points

With the boiler case on and the boiler running at maximum output (refer to section 7.5.1 "Setting the boiler to maximum").

- Insert the analyser probe into the air intake sample point.
- Ensure that the probe reaches the centre of the air intake, adjust the cone on the probe so that it seals the sample point and correctly positions the end of the probe.
- Allow the readings to stabilise and check that:
 - O₂ is equal to, or greater than 20.6%.
 - CO₂ is less than 0.2%
- If the readings are outside these limits then this indicates that there is a problem with the flue system or combustion circuit, e.g. missing or dislodged seals.

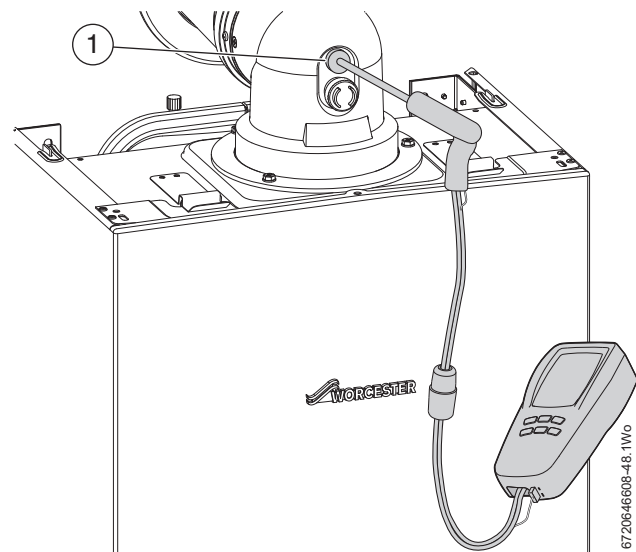

Fig. 64 Flue integrity test

7.4 COMPONENT ACCESS

To gain access to the components, remove the outer case:

1. Remove the two screws securing the control panel.
2. Release the two catches.
3. Pull the bottom of the control panel forward and down.
4. Lower the control panel into the service position
5. Undo and remove the two bottom retaining screws.
6. Lift the spring clips on top of the case.
7. Pull the case towards you to remove.

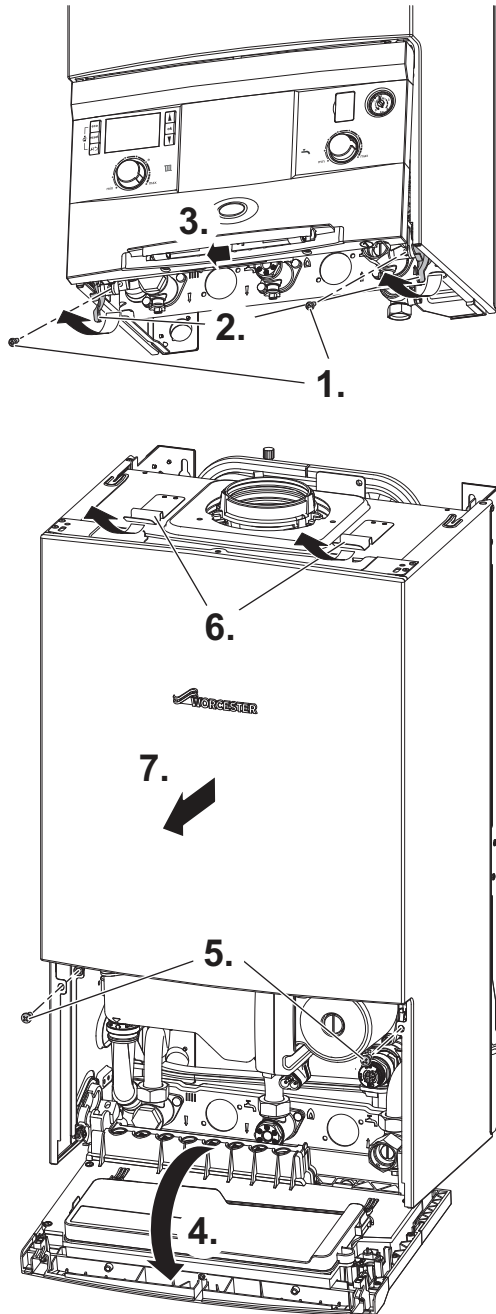

Fig. 65 Component access

7.5 FAN PRESSURE TEST



This test is to determine if the heat cell requires cleaning or attention.

Before setting the boiler to maximum output for the fan pressure test, refer to figure 67:

- ▶ Switch the boiler off.
- ▶ Remove the combustion air intake pipe (1).
- ▶ Remove the fan pressure test point cover (2).
- ▶ Connect the digital manometer pipe (3) to the fan pressure test point (4).
- ▶ Replace the combustion air intake pipe.
- ▶ Switch the boiler on.
- ▶ Set the boiler to maximum output.

7.5.1 SETTING THE BOILER TO MAXIMUM

To set the boiler to maximum output, refer to figure 66:

1. With the control panel in the operating position, press and hold the **eco** and **Max** buttons together for at least five seconds.
 - The chimney sweep symbol (1) will be displayed at the top of the screen.
 - The word "Max" will flash at the bottom of the screen.
 - The boiler will take approximately 30 to 35 seconds to ramp up to maximum output.
 - Allow the boiler to stabilise at maximum output for at least 10 minutes.
- ▶ Ensure that the boiler does not modulate.

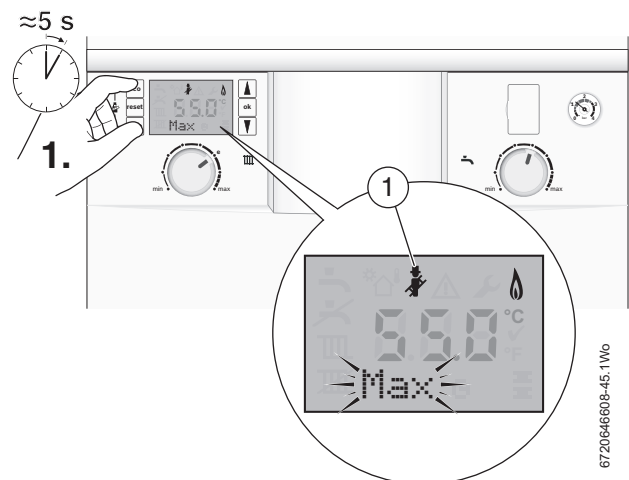

Fig. 66 Set boiler to maximum

6720646609-19.1Wo

6720646608-45.1Wo

7.5.2 FAN PRESSURE

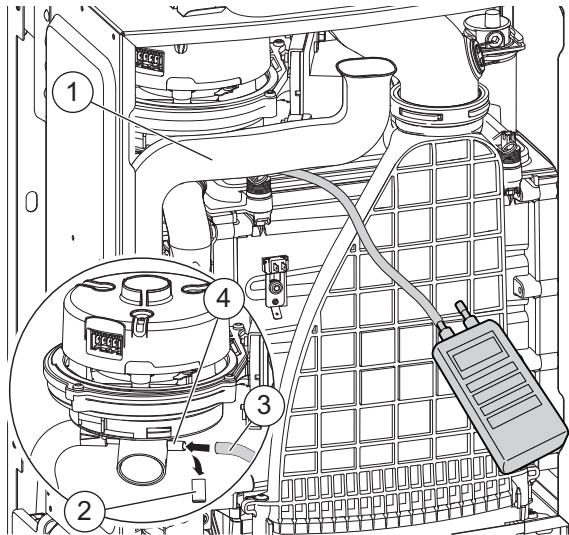

Fig. 67 Fan pressure test point

6720646608-50.3W6

NOTICE: Fan pressure test

- ▶ The boiler must be run at maximum output for the fan pressure test and flue gas analysis.

With the combustion air intake pipe fitted and the boiler running at maximum output, measure the fan pressure:

- ▶ The pressure will read negative, refer to the chart in the figure below.

FAN PRESSURE TEST

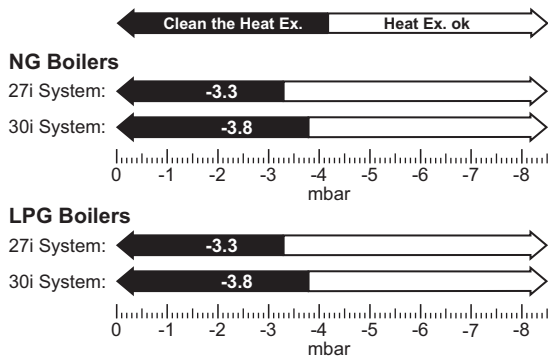

6720646609-34.2W6

Fig. 68 Fan pressure readings

- ▶ If the manometer reading is in the white area of the chart the heat exchanger/exhaust path/siphon does not require attention.
- ▶ If the manometer reading is in the black area of the chart then carry out the following checks:
 - Check that the siphon is not blocked.
 - Check the exhaust paths for restrictions.
 - Clean the heat exchanger with a suitable cleaning tool, refer to section 7.7 - Cleaning the heat exchanger.
- ▶ Re-check the fan pressure readings.

If the boiler, after completing the above checks, fails the fan pressure test then contact Worcester, Bosch Group for advice.

- ▶ After the measurements are taken switch the boiler off.
- ▶ Remove the combustion air intake pipe.
- ▶ Disconnect the manometer and replace the test point cover.
- ▶ Replace the combustion air intake pipe.

7.6 FLUE GAS ANALYSIS

NOTICE: Combustion testing

- ▶ Combustion testing must be carried out by a competent person. Testing must not be attempted unless the person carrying out the combustion check is equipped with a Combustion Analyser conforming to BS 7927 and is competent in its use.

NOTICE: Gas inlet pressure

- ▶ Ensure that the gas inlet pressure has been checked and is satisfactory, refer to section 6.5.1

COMBUSTION TEST

i If the optional integral diverter valve is fitted (not supplied) and the Service mode and maximum output are selected the boiler will operate both the Central Heating and DHW circuits with the diverter valve in the mid position. This is to allow sufficient time for the setting procedure. When the water temperature reaches 75°C the diverter valve will switch to CH only. For S and Y plan systems only use the Central Heating circuit.

- ▶ Connect the flue gas analyser to the flue gas sampling point (1) as shown in the figure below.
- ▶ Ensure that the probe reaches the centre of the flue gas exhaust, adjust the cone on the probe so that it seals the sample point and correctly positions the end of the probe.
- ▶ Press the **eco** and **↔** buttons together
 - The chimney sweep symbol will be displayed at the top of the screen.
 - “Max” will flash at the bottom of the screen.
 - The boiler will ramp up to maximum output in approximately 30 to 35 seconds.
- ▶ Run the boiler at maximum output for at least 10 minutes.
- ▶ Check the CO/CO₂ readings against the information in table 28 & 29.

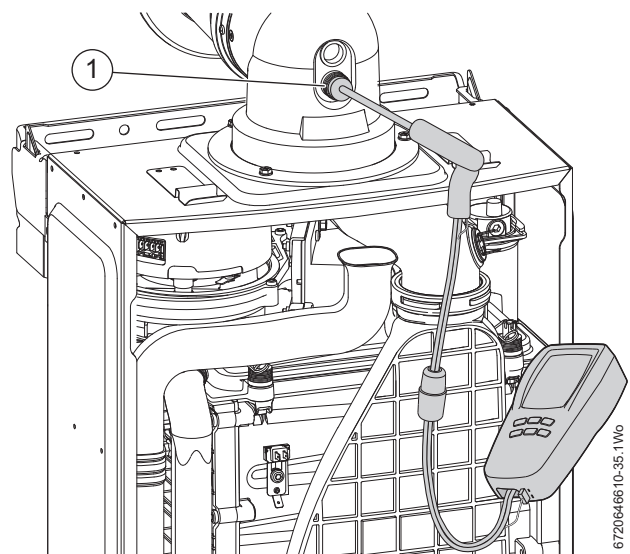



Fig. 69 Combustion test

6720646610-35.1W6

- ▶ Check CO is less than 200ppm.
- ▶ Set the boiler to minimum power by pressing the down arrow button.
 - “Min” will flash at the bottom left of the screen.
 - The boiler will take 30 to 35 seconds to ramp down to minimum output.
 - Allow the boiler to stabilise at minimum output for at least 10 minutes.

- ▶ Check the CO/CO₂ readings against the information in table 28 & 29.
- ▶ Check that the CO is less than 200ppm.
- ▶ Return the boiler to maximum, by pressing the UP arrow button, and re-check the CO/CO₂.
 - “Max” will flash at the bottom left of the screen.
 - The boiler will take approximately 30 to 35 seconds to ramp up to maximum output.
 - Allow the boiler to stabilise at maximum output for at least 10 minutes.
- ▶ If correct, press the  button and the boiler will return to normal operation.
- ▶ Re-assemble and refit boiler case.



NOTICE: Minimum CO₂

- ▶ The minimum CO₂ reading must be at least 0.2 lower than the maximum CO₂ reading.

NG Appliances		
Output	CO ₂ Reading	CO Reading
Maximum setting (measured after 10 minutes)	Between 8.5 and 10.1.	Less than 200ppm
Minimum setting (measured after 10 minutes)	A minimum 0.2 lower than the maximum reading taken but above 7.5%	Less than 50ppm

Table 28 NG CO/CO₂ settings

LPG Appliances		
Output	CO ₂ Reading	CO Reading
Maximum setting (measured after 10 minutes)	Between 9.8 and 11.1.	Less than 200ppm
Minimum setting (measured after 10 minutes)	A minimum 0.2 lower than the maximum reading taken but above 8.5%	Less than 50ppm

Table 29 LPG CO/CO₂ settings

Example of a Natural Gas appliance reading:

- Maximum CO₂ reading taken = 9.5%
- The minimum CO₂ reading must be between 8.0% and 9.3% (a minimum 0.2 lower than the maximum reading of 9.5%)

If the boiler fails the combustion test, check:

1. Air intake for restriction
2. Cleanliness of the heat cell, condition of the burner, plus blockages in the condensate disposal.

7.7 CLEANING THE HEAT EXCHANGER



NOTICE: Gaskets and seals

- ▶ Replace the burner and electrode assembly gaskets and the Flueway sump seal after cleaning the heat exchanger.
- Do not attempt the cleaning procedure unless new gaskets and seals are available.



There is an optional tool available to assist in cleaning the heat exchanger, part number 7 746 901 479

The following items will have to be removed to gain access to the heat exchanger for cleaning:

- ▶ Lower the control panel into the service position.
- ▶ Remove the case.

- ▶ Disconnect electrical wires to the fan, ignition transformer, spark electrodes, flue overheat thermostat, main heat exchanger temperature sensor and flow pipe temperature sensor.
- ▶ Flueway
- ▶ Fan assembly
- ▶ Ignition transformer
- ▶ Spark electrode assembly
- ▶ Burner housing, burner and gasket

Refer to sections 7.8.10 to 7.8.14 for instructions on how to remove the items to gain access to the heat exchanger channels so that the heat exchanger can be cleaned

7.7.1 CLEANING THE SIPHON

1. Protect the controller from water ingress and disconnect the black discharge hose from the wall frame connector.
 2. Rotate the siphon body clockwise to release the bayonet connection.
 3. Pull the siphon body down and away from the boiler.
- ▶ Empty the water and debris into a suitable container.
 - ▶ Visually inspect the siphon to ensure that it is clean and free from debris.

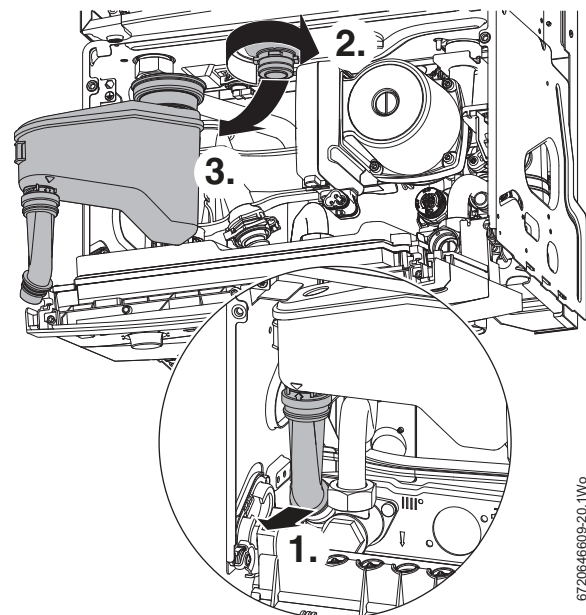



Fig. 70 Cleaning the siphon

REFITTING THE SIPHON

- ▶ Fill siphon with 200 to 250 millilitres of water.
1. Push the siphon up onto the sump assembly until it fully engages with the sump connection.



NOTICE: Do not use solvents, adhesive or lubricant when pushing the pipe onto the rubber connector.

2. Twist the siphon to the left to secure the bayonet connection.
3. Push the black discharge hose, onto the wall frame connector, until fully engaged.

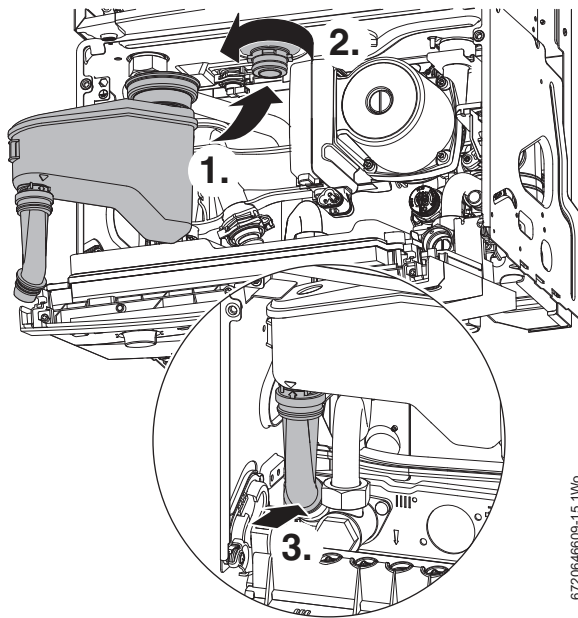

Fig. 71 Fitting siphon

7.7.2 CLEANING THE PRIMARY HEAT EXCHANGER

SINGLE BLADED TOOL AND BRUSH

Use a suitable blade to clean the heat exchanger channels. There is an optional tool available to clean the heat exchanger, part number 7 746 901 479.

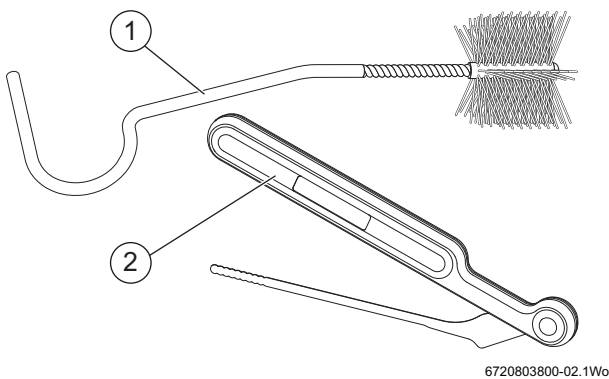

Fig. 72 Single-bladed cleaning tool and brush

- ▶ Visually inspect the inside of the heat exchanger by shining a torch from the top down into the sump area.
- ▶ When there is little or no light visible this would suggest that those channel(s) are restricted.
- ▶ It is recommended that all channels are cleaned.
- ▶ Remove the siphon and place a suitable container under the outlet to catch the water and debris.
- ▶ Protect the controller from water ingress.

To clean the rear and middle channel of the heat exchanger

1. Orient the cleaning tool (2) as shown in figure 73 and insert the tool into the rear or middle channels for cleaning.
2. Move the cleaning tool handle in an up and down motion, using the front edge of the heat exchanger as a pivot, to clean the channel.

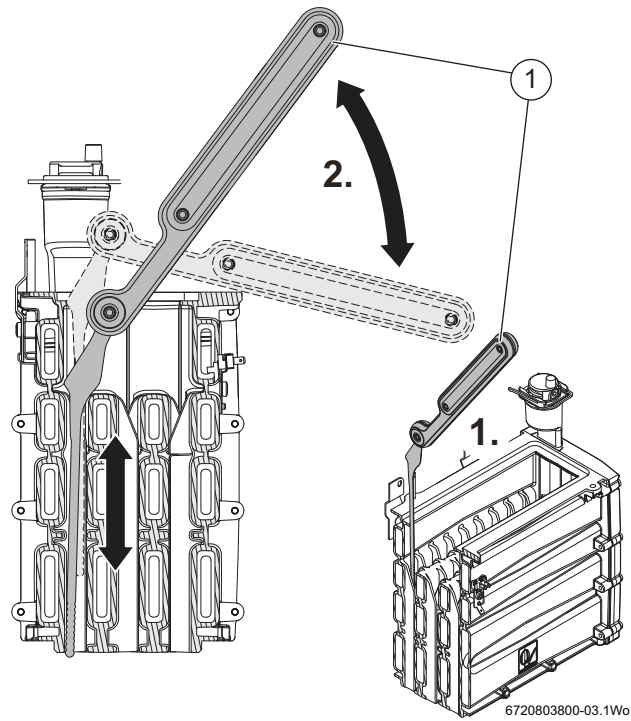

Fig. 73 Heat exchanger cleaning tool

To clean the front channel of the heat exchanger

3. Orient the cleaning tool (2) as shown in figure 74 and insert the tool into the front channel for cleaning.
 4. Move the cleaning tool handle in an up and down motion, using the front edge of the heat exchanger as a pivot, to clean the channel.
- ▶ Use the brush to dislodge the debris and pour water down the channels to flush out the debris.

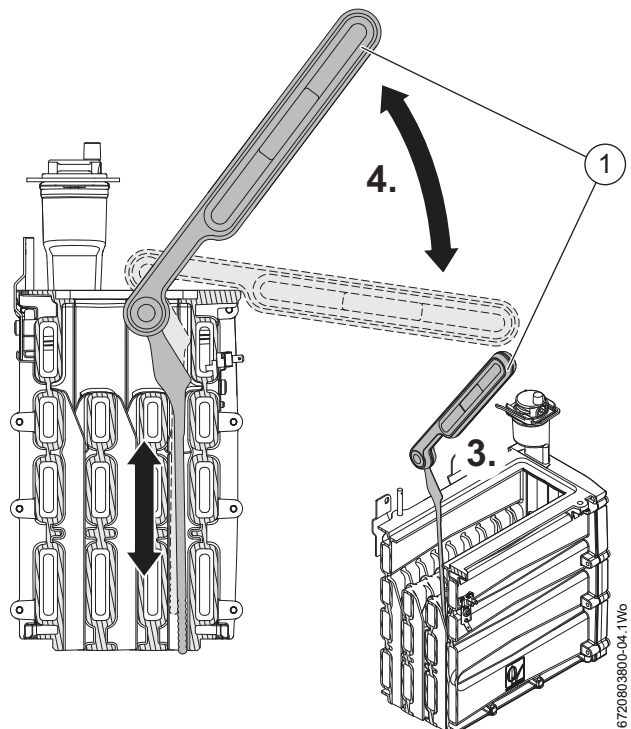

Fig. 74 Cleaning the front channels



On completion of the heat exchanger cleaning and re-assembly, perform the fan pressure test as described in section 7.5.2

7.8 REPLACEMENT OF PARTS

CAUTION: Mains supplies:

- ▶ Turn off the gas supply and isolate the mains supplies before starting any work on the boiler and observe all relevant safety precautions.

CAUTION: Component replacement:

- ▶ Replace the burner housing gasket and the Flueway sump seal when re-assembling the heat exchanger. Do not reassembly the heat exchanger and Flueway until new gaskets and seals are available.
- ▶ After replacement of a gas related component, where a gasket or seal has been disturbed or replaced, check for gas tightness using a gas sniffer/analyser.
- ▶ On re-assembly check all affected seals for cracks, hardness and deterioration. If damaged or in any doubt the seal must be replaced.
- ▶ Also after re-assembly, carry out the following checks: Fan pressure in section 7.5, Flue gas analysis in section 7.6.

7.8.1 REMOVING THE OUTER CASE

Remove the bottom panel:

1. Pull the catch down.
2. Slide the panel forward and down to remove

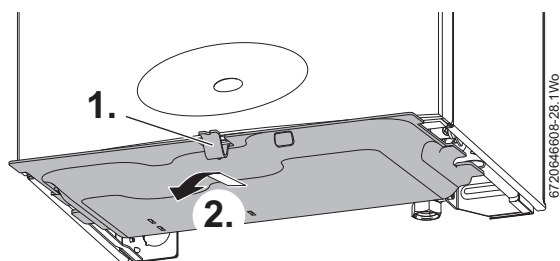

Fig. 75 Bottom panel

1. Locate and remove the two screws under the front of the boiler.
2. Pull the two catches, located under the front of the boiler, down to release the control panel
3. Pull the bottom of the control panel forward slightly and down.
4. Allow the control panel to rotate down on the hinges.
5. Remove the two screws securing the bottom of the case.
6. Release the two catches on top of the boiler.
7. Pull the case towards you and remove.

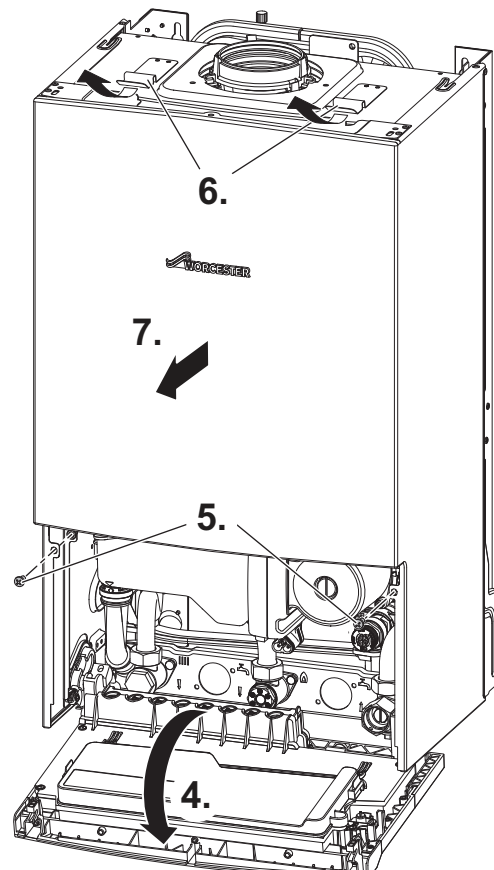
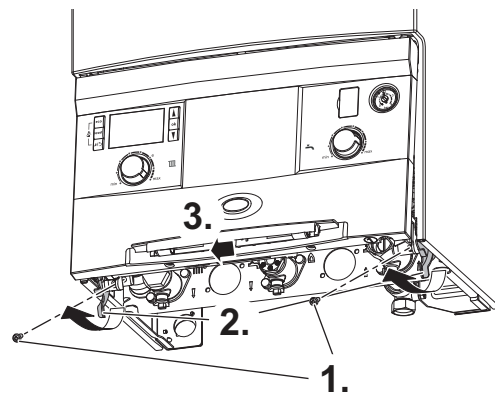

Fig. 76 Removing outer case

7.8.2 DRAINING THE BOILER

Many of the tasks in this section require that the boiler be isolate and drained.

1. Connect a suitable hose firmly to the drain point and run the hose outside to a suitable point or container.
2. Turn the drain valve a ¼ turn anti-clockwise to open the drain. Turn the valve firmly clockwise to close.

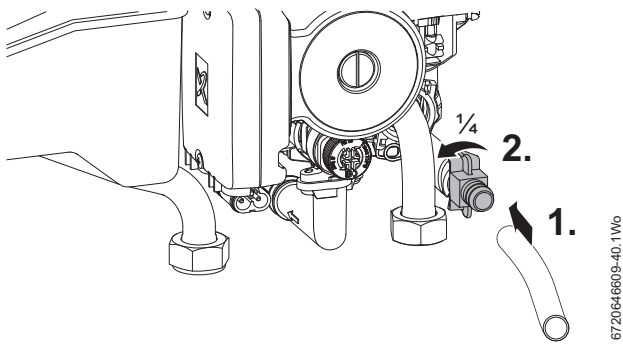

Fig. 77 Draining the boiler

7.8.3 SIPHON REMOVAL

- ▶ 1. Disconnect the discharge hose from the wall frame connector.
- ▶ 2. Rotate the siphon body clockwise to release the bayonet connection.
- ▶ 3. Pull the siphon body down and away from the boiler.

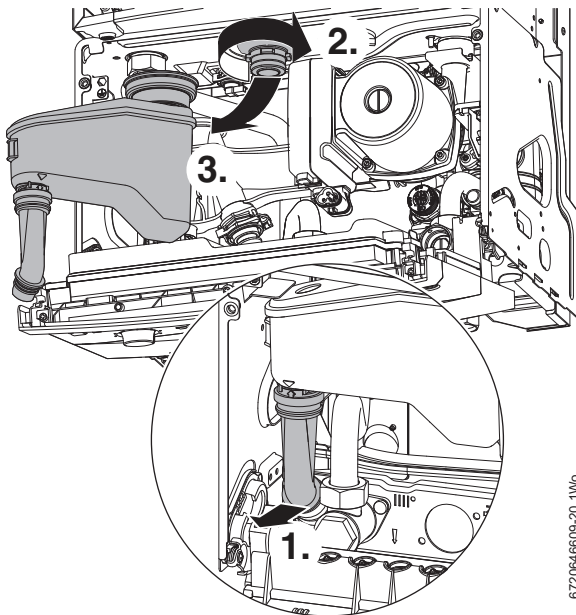

Fig. 78 Syphon removal

7.8.4 PRIMARY SENSOR (CH NTC)

- ▶ Remove the combustion air inlet pipe from the pre-mix unit, rotate anti-clockwise and pull away from the fan assembly.
- ▶ Ease the gas pipe to the left.
- ▶ Disconnect the lead to the sensor.
- ▶ Remove the sensor by pulling forward.
- ▶ Replace the sensor onto the flow pipe.
- ▶ Connect the lead to the sensor.
- ▶ Re-fit the combustion air inlet pipe to the pre-mix unit.

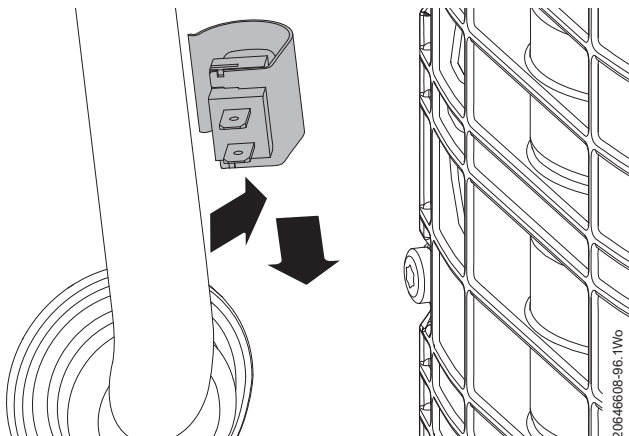

Fig. 79 Primary sensor

7.8.5 MAXIMUM SAFETY SENSOR

- ▶ Disconnect the lead to the maximum safety sensor.
 1. Remove the screw securing the sensor.
 2. Remove the sensor from the heat exchanger.
- ▶ When replacing the sensor, ensure that the assembly is properly located on the orientation pin.

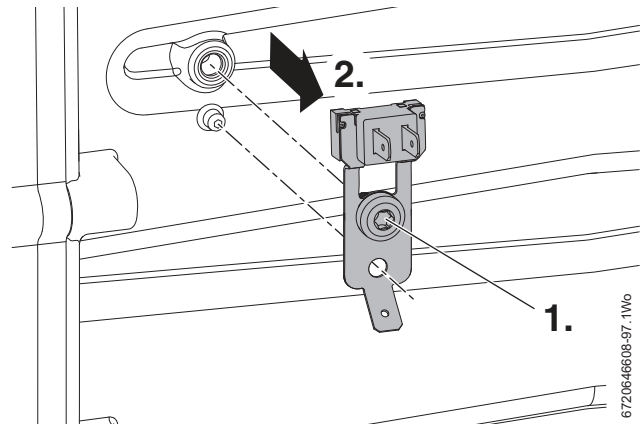

Fig. 80 Overheat sensor

7.8.6 FLUE OVERHEAT THERMOSTAT

- ▶ Disconnect the lead to the flue overheat thermostat.



Take care not to damage the housing when removing the thermostat.

- ▶ Using a small screwdriver, gently prise the thermostat from the housing taking care not to damage the housing or grommet.

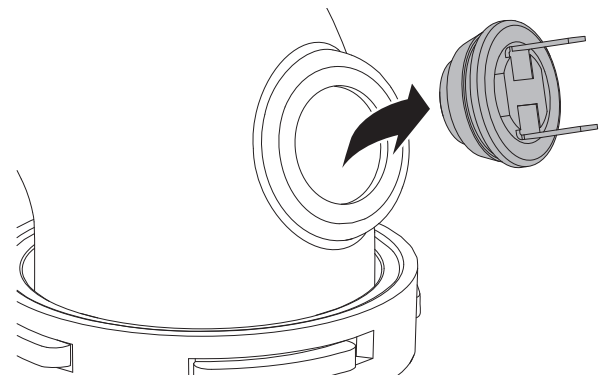

Fig. 81 Flue overheat thermostat

- ▶ To replace, push the thermostat and new grommet gently back into the opening until contact with the locating ridge is felt.
- ▶ The Flueway will have to be removed if the thermostat falls into the housing, refer to section 7.8.10.

7.8.7 AIR PRESSURE SWITCH

NOTICE: Air Pressure Switch

- ▶ Ensure that the tube is reconnected to the Air Pressure Switch

To remove the Air pressure switch assembly:

- ▶ Slacken the two screws [1] but do not remove
- ▶ Remove the connector from the terminals [2]
- ▶ Disconnect the tube from the flue pipe
- ▶ Slide the assemble to left to release the retaining bracket
- ▶ Remove the assembly

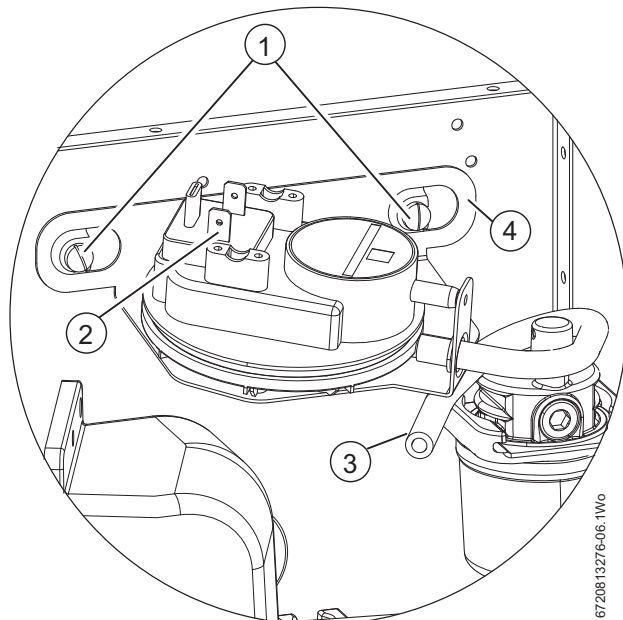

Fig. 82

To remove and replace the Air pressure switch:

- ▶ Remove the two screws [5] retaining the switch to the bracket [4].
- ▶ Disconnect the tube [3] from the switch.
- ▶ Fit the new switch to the bracket and secure with the two screws [5].
- ▶ Re-connect the tube [3] to the switch, ensuring routing is looped as in figure 82.
- ▶ Re-connect the connectors to the terminals [2].
- ▶ Align the Air pressure switch bracket [4] over the two screws [1] and slide the assembly to the right, tighten the screws to secure.

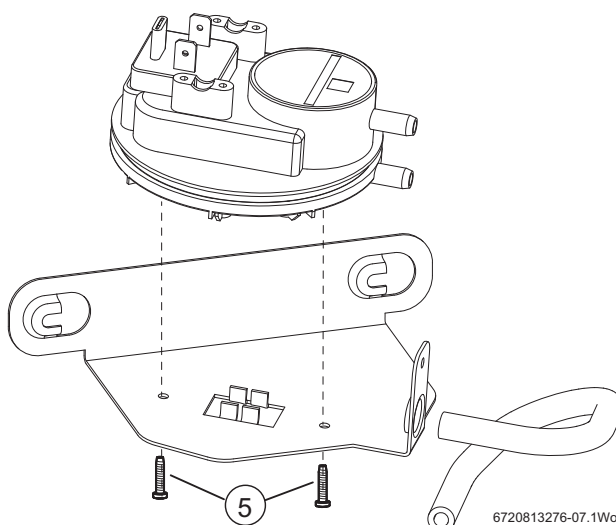

Fig. 83

7.8.8 AUTO AIR VENT

Ensure that the boiler has been fully drained.

1. Remove the spring clip completely.
2. Lift the air vent out of the housing and remove.

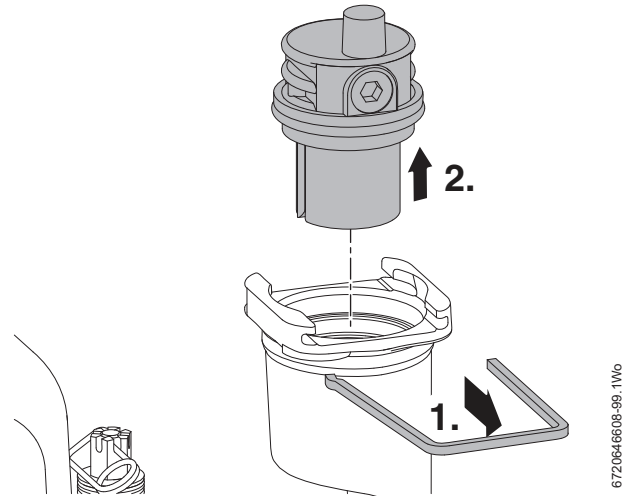

Fig. 84 Auto air vent

When re-assembling ensure that the "O" ring is fitted to the Auto air vent and NOT the heat exchanger, otherwise the Air vent will be difficult to fit. Apply silicone grease to the "O" ring to ease assembly.

7.8.9 GAS VALVE

- ▶ Isolate the mains electrical supply and the gas supply at the boiler gas cock.
- ▶ Remove the combustion air inlet pipe.
- ▶ Disconnect the electrical connector from the valve

 1. Remove the gas pipe from the top of the valve.
 2. Undo the bottom gas pipe connection.
 3. Remove the screw securing the gas valve.
 4. Lift the gas valve to clear the bottom gas connection.
 5. Pull the gas valve forward out of the boiler.

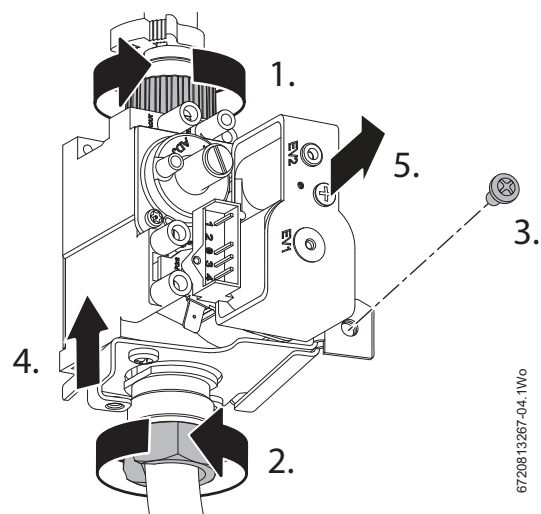

Fig. 85 Gas valve

- ▶ When fitting the new valve, start with the bottom gas connection and tighten by hand before making any other connections to the valve.
- ▶ Secure the valve with the screw.
- ▶ Tighten the bottom connection firmly with a suitable spanner.
- ▶ Connect the top gas pipe.
- ▶ Reconnect the electrical connector.
- ▶ Open the boiler gas isolator.
- ▶ Check all the gas connections for gas tightness.

7.8.10 FAN ASSEMBLY

CAUTION: Component replacement:

- ▶ After replacement of a gas related component, where a gasket or seal has been disturbed or replaced, check for gas tightness using a gas sniffer/analyser.
- ▶ On re-assembly check all affected seals for cracks, hardness and deterioration. If damaged or in any doubt the seal must be replaced.
- ▶ Also after re-assembly, carry out the following checks:
Fan pressure in section 7.5,
Flue gas analysis in section 7.6,

To remove the fan, disconnect the electrical mains and gas supplies, and remove the following components:

- Flueway
- Combustion air inlet pipe and gas pipe

FLUEWAY REMOVAL

CAUTION: Flueway sump seal.

- ▶ Replace the sump seal every time that the Flueway to sump connection is disturbed.

▶ Refer to figure 86 for Flueway removal.

1. Release the two screws securing the Flueway to the sump.
2. Using a screwdriver under the tabs (1) next to the screws, lever the Flueway up to clear the seal and pull the Flueway forward.
3. Rotate the exhaust pipe to the left and pull the Flueway down to separate from the exhaust pipe.

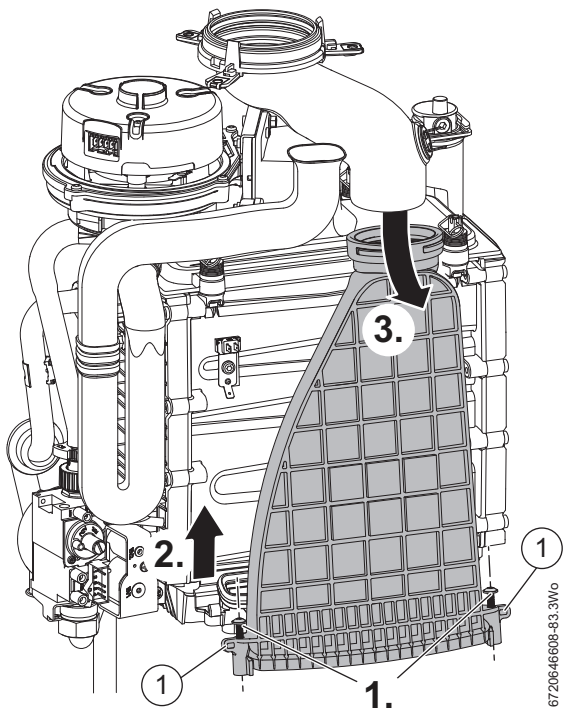

Fig. 86 Flueway removal

REMOVE THE USED SEAL

4. Discard the “tubular” seal [2] or the “moulded” seal [3], depending on which type is fitted and replace with the seal that is provided.

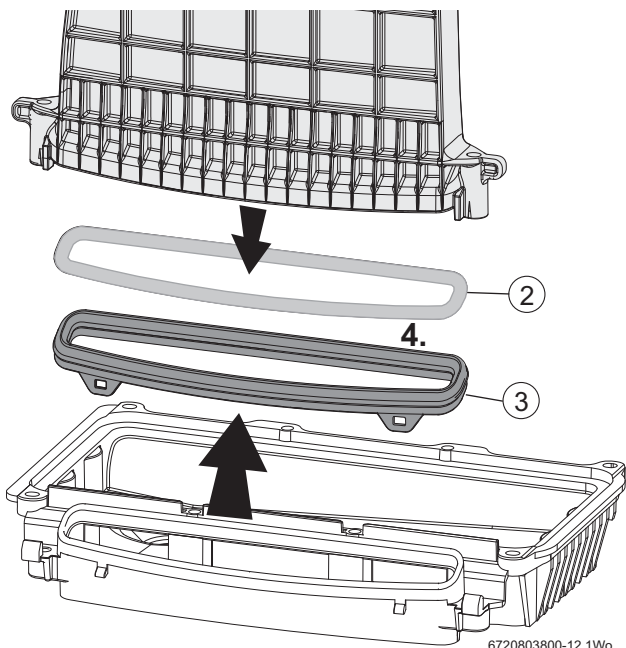

Fig. 87 Remove the existing seal

FITTING THE “MOULDED” SUMP SEAL

1. Place the seal [3] on the sump interface.
 2. Ensure that the lug flaps are mounted onto the sump lugs.
- Before fitting the Flueway:
- ▶ Ensure that the seal is clean and free from debris.

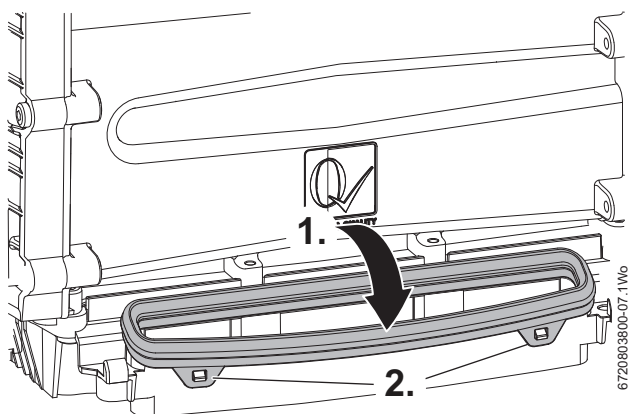

Fig. 88 Moulded style seal

FITTING THE “TUBULAR” SUMP SEAL

3. Fit the Flueway sump seal [2] into the Flueway. Ensure the seal is fitted fully into the recess in the underside of the Flueway.
- Before fitting the Flueway:
- ▶ Ensure that the seal is clean and free of debris.

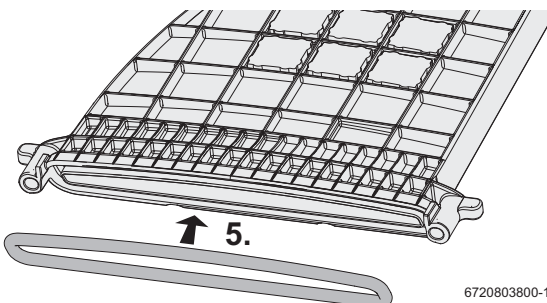

Fig. 89 Tubular style sump seal

COMBUSTION AIR INLET AND GAS PIPE DISCONNECTION

1. Rotate the combustion air inlet pipe anti-clockwise to release from the fan assembly and pull away from the fan.
2. Undo the top gas pipe connector at the gas valve.

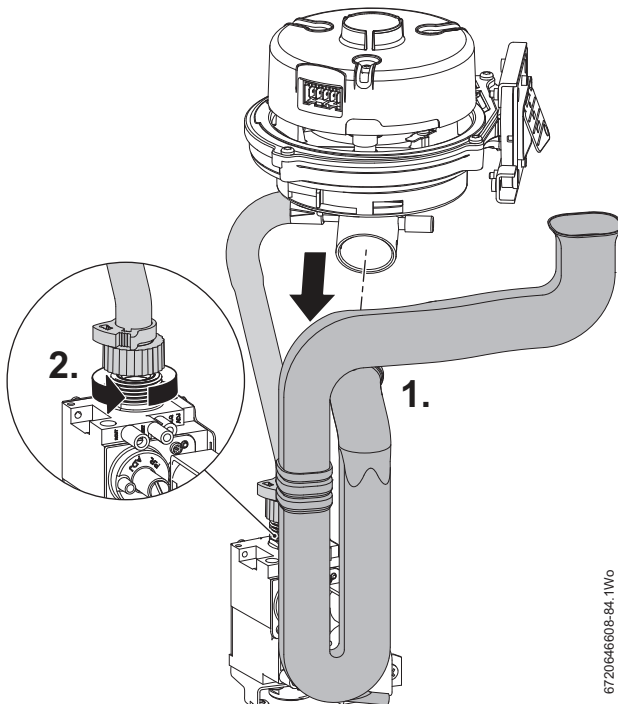

Fig. 90 Combustion air inlet pipe removal

FAN REMOVAL



The boiler case is shown removed to aid clarity.

3. Rotate the exhaust pipe to the left to gain access to the fan assembly securing screws.
4. Support the weight of the fan and remove the two screws securing the fan.

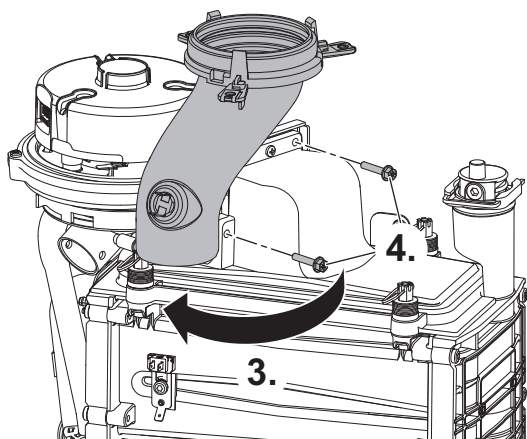

Fig. 91 Fan removal 1

5. Rotate the exhaust pipe back to the right.
6. Pull the fan assembly away from the mount, lift and rotate the fan towards you. Ensure that the front of the fan clears the left hand front castellated nut securing the burner housing.
7. Pull the gas pipe off the fan body connection, the pipe is secured by the interference fit between the pipe and connector.
8. Remove the electrical connector and earth from the fan.



When refitting the rubber gas pipe, ensure that the pipe is correctly oriented by aligning the notch in the pipe with the lug on the fan connector. Do not kink the pipe. There is a raised arrow on the pipe indicating the location of the notch.

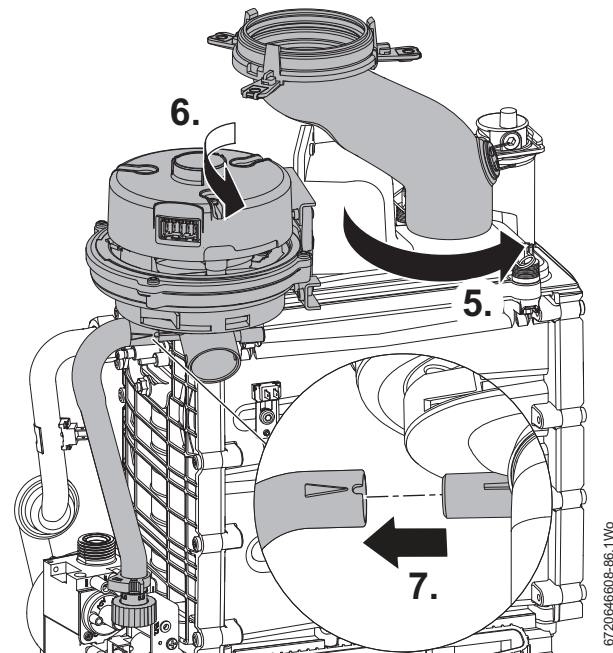

Fig. 92 Fan removal 2

7.8.11 AIR/GAS FLAP VALVE ASSEMBLY

1. Remove the single screw securing the air/gas flap valve assembly.
2. Pull the flap assembly away from the housing.

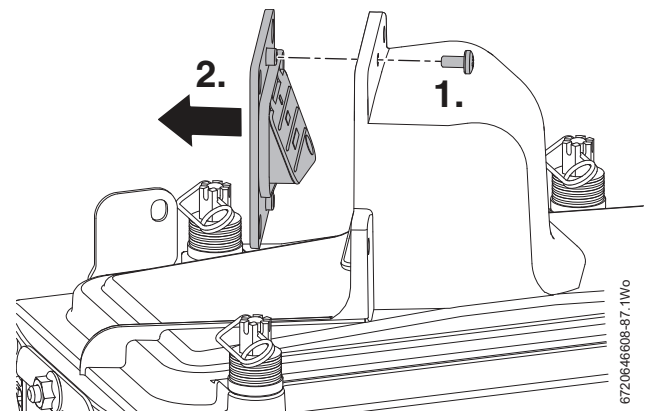

Fig. 93 Air/gas flap valve

7.8.12 IGNITION TRANSFORMER

To remove the ignition transformer

- ▶ Remove the combustion air inlet pipe.
- ▶ Ensure that the harness wires are disconnected from the transformer.
- ▶ Remove the electrode cables.
- ▶ Lift the transformer from the retaining clip.

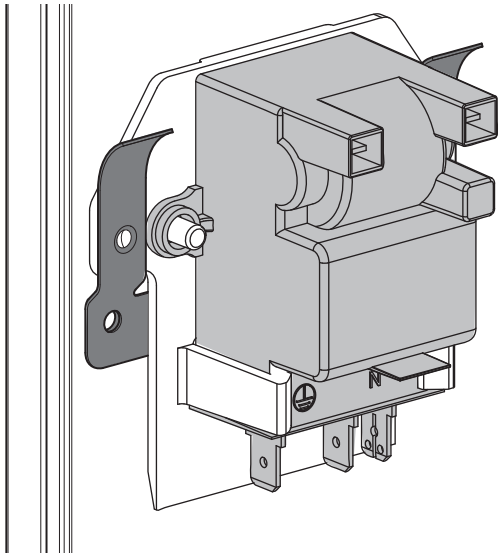

Fig. 94 Ignition transformer

6720813276-08.1Wo

7.8.13 ELECTRODE ASSEMBLY



CAUTION: Component replacement:

- ▶ After replacement of a gas related component, where a gasket or seal has been disturbed or replaced, check for gas tightness using a gas sniffer/analyser.
- ▶ Also after re-assembly, carry out the following checks:
Fan pressure in section 7.5,
Flue gas analysis in section 7.6,

To remove the spark electrode assembly:

1. Undo and remove the two nuts securing the electrode assembly
 2. Rotate the electrode assembly down and forward to remove from the Heat exchanger.
- ▶ Inspect the spark electrodes (2), ionisation probe (3) and ceramics for signs of contamination or damage, replace as necessary.
 - ▶ If necessary, clean the spark electrodes and ionisation probe with a plastic scouring pad.
 - ▶ Re-assemble with a new electrode gasket (1),

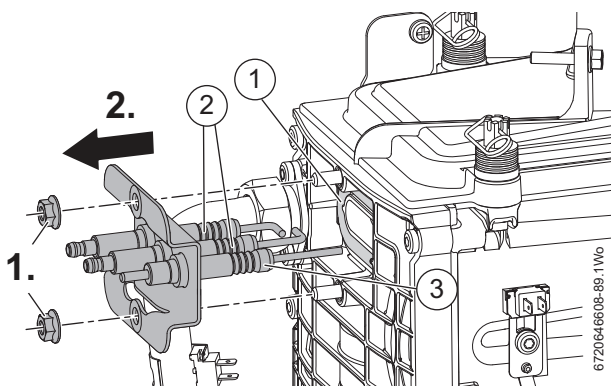

Fig. 95 Electrode assembly

6720646608-88.1Wo

7.8.14 BURNER HOUSING, BURNER/ GASKET



The front two bolts retaining the burner housing are NOT captive and will drop out when the nuts are removed.

To remove the burner housing.

1. Release and remove the four spring pins from the castellated nuts.
2. Undo the front two castellated nuts/springs and remove and retain along with the front two bolts (1).
Slacken the two rear castellated nuts/springs, but do not remove.

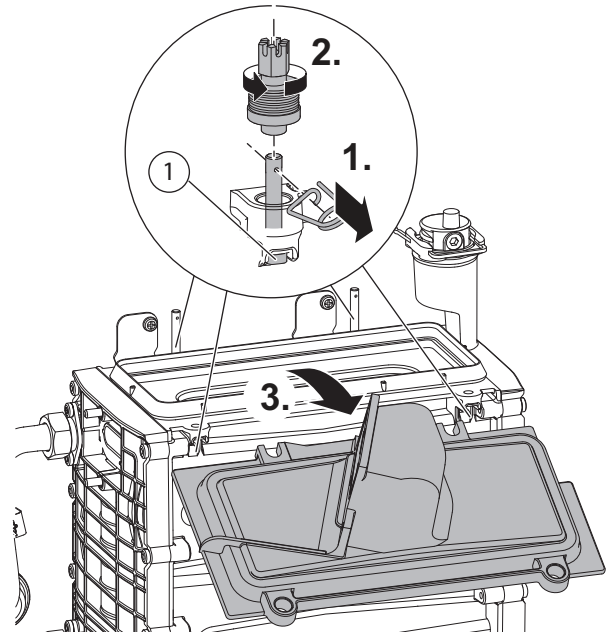

Fig. 96 Burner housing

6720646608-90.1Wo

3. Pull the burner housing up and forward to remove.

To remove the burner and gasket.

1. Lift the gasket (1) and burner mesh (2) from the heat exchanger body.
- ▶ When fitting the burner, ensure that the convex side of the burner faces down into the heat exchanger.
 - ▶ Always fit a new gasket (1) when re-assembling the heat exchanger.

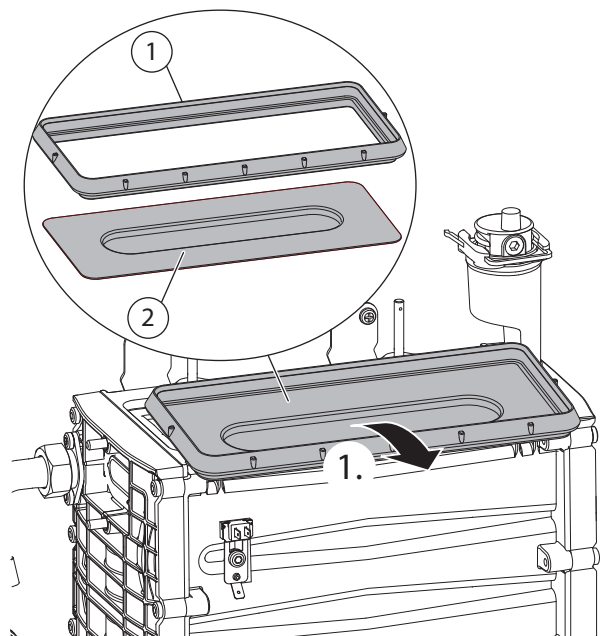

Fig. 97 Burner and gasket

6720646608-91.1Wo

TIGHTENING DOWN THE BURNER HOUSING

1. Tighten the burner housing castellated nuts [1] down gradually and evenly and in a rotating sequence.
 2. Tighten the castellated nuts down until they “bottom out” on the heat cell, as indicated by the arrow on the figure below.
- Fit the spring clip [2] to secure the castellated nuts, if the hole does not line up with a space, back the nut off slightly until the hole does align with the slot.

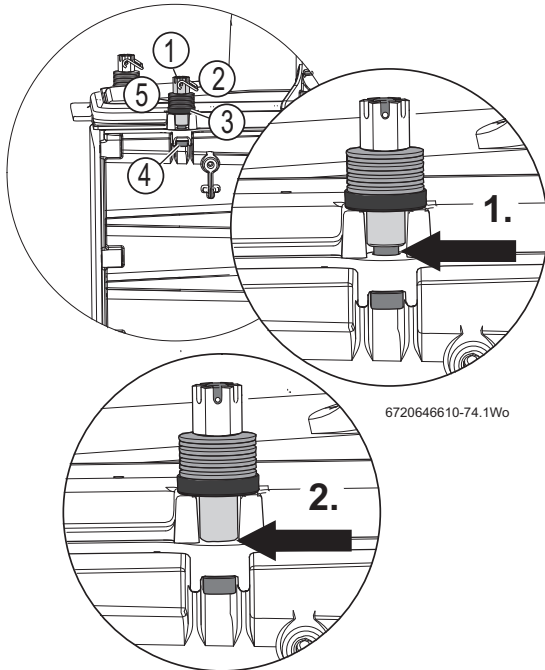

Fig. 98 Castellated nuts

- [1] Castellated nut
- [2] Spring clip
- [3] Washer
- [4] Burner housing bolts
- [5] Tension springs

7.8.15 HEAT EXCHANGER



Before removal:

- Isolate the electrical power to the boiler.
- Drain the system.

HEAT EXCHANGER DISCONNECTION

1. Undo the flow and return connections.
 2. Pull both the flow and return pipes away from the heat exchanger.
- Replace the fibre washers (1) when replacing the heat exchanger.

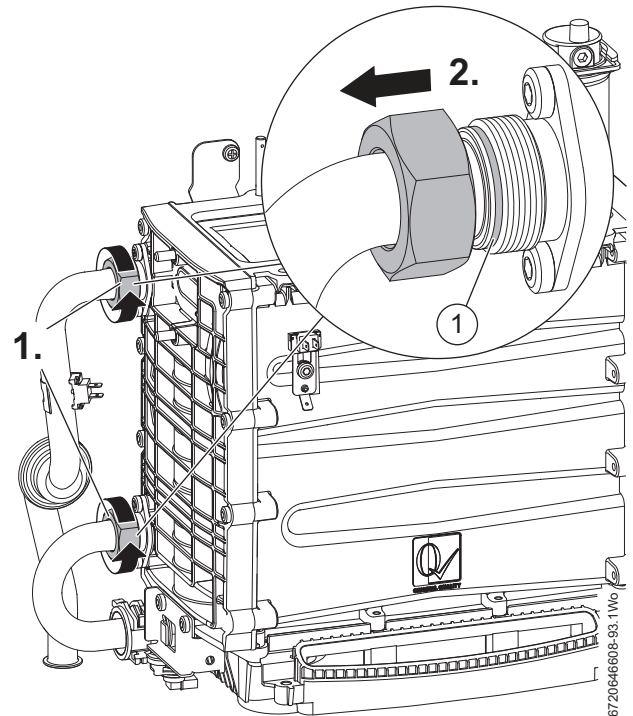

Fig. 99 Heat exchanger disconnection

HEAT EXCHANGER REMOVAL

- Ensure any electrical wires or connectors are removed.
 - Remove the Auto air vent (refer to section 7.8.8) to ease removal of the heat exchanger
1. Unscrew the heat exchanger retaining nut.
 2. Remove the heat exchanger retaining nut.
 3. Remove the two screws securing the heat exchanger to the air box.
 4. Lift the heat exchanger until the lower connection clears the hole in the air box.
 5. Pull the heat exchanger towards you to remove.



CAUTION: Component replacement:

- After replacement of a gas related component, where a gasket or seal has been disturbed or replaced, check for gas tightness using a gas sniffer/analyser.
- Also after re-assembly, carry out the following checks:
 - Fan pressure in section 7.5,
 - Flue gas analysis in section 7.6,

- Re-assemble in the reverse order.

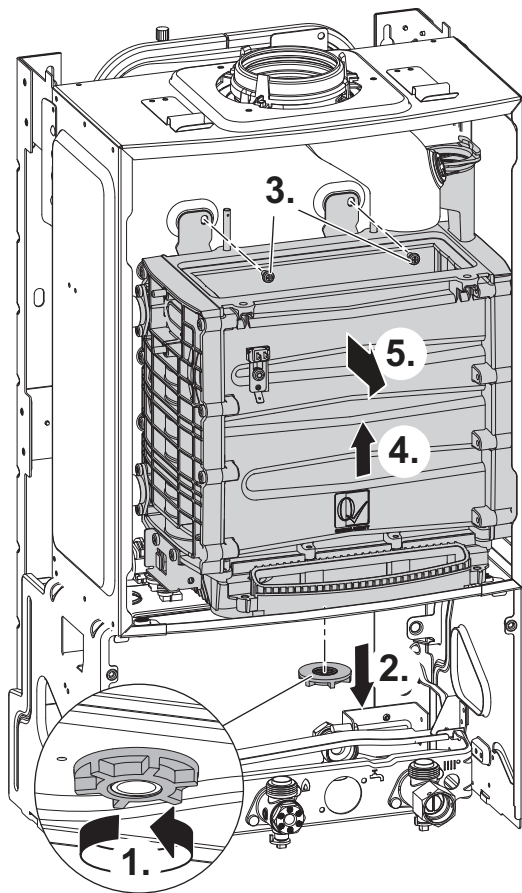

6720646609-22.1W0

Fig. 100 Heat exchanger removal

7.8.16 DIVERTER VALVE MOTOR AND DIVERTER VALVE REMOVAL



If the optional integral diverter valve kit has been fitted.

- ▶ Disconnect the lead from the diverter valve motor.
- 1. Pull the diverter valve motor from the housing.
- 2. Undo and remove the two screws from the diverter valve motor housing.
- 3. Pull the diverter valve motor housing from the diverter valve assembly.



When re-fitting the diverter valve motor, ensure that the motor actuator is correctly connected to the forked lever on the diverter valve.

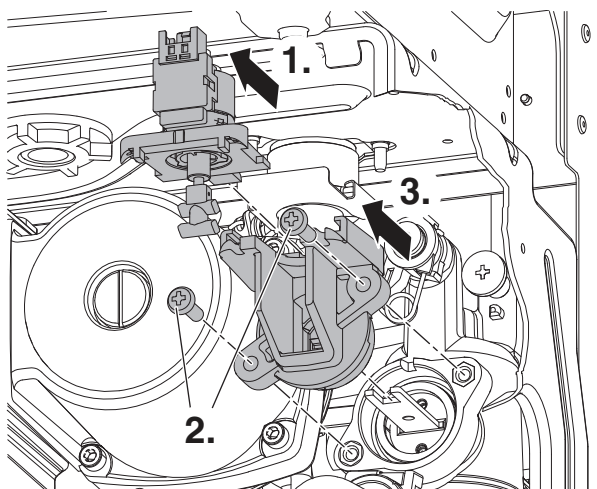

6720646609-21.1W0

Fig. 101 Diverter valve

7.8.17 PUMP HEAD



- Before removal:
- ▶ Isolate the electrical power to the boiler.
 - ▶ Drain the system.
 - ▶ There may be water inside the pump. Protect any electrical items from water ingress.

1. Disconnect the main electrical connector from the bottom of the pump.
 2. Remove the four screws securing the pump head.
 3. Pull the pump free from the housing.
- ▶ Use a screwdriver to gently disconnect the three wire connector from the bottom of the pump.
 - ▶ Ensure that the pump body is completely dry before fitting the new pump head, failure to do so may result in damage to the pump.

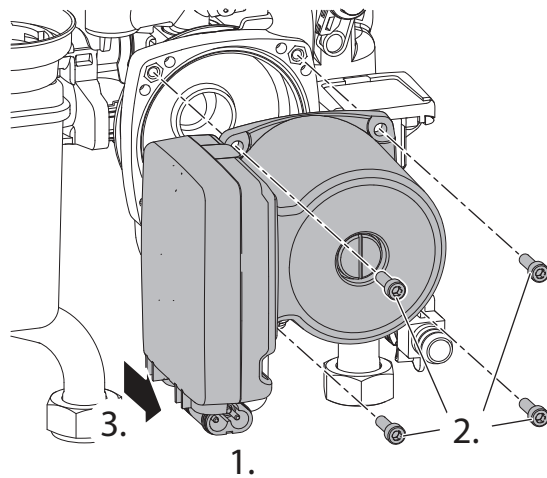

6720813280-08.1W0

Fig. 102 Pump head removal

7.8.18 PRESSURE GAUGE

- ▶ Ensure that the boiler is fully drained.
1. Remove the securing screw and plate.
 2. Prise the lugs apart and remove the pressure gauge.
 3. Withdraw the spring clip from the pressure sensing head housing.
 4. Remove the pressure sensing head and pressure gauge capillary from the housing.

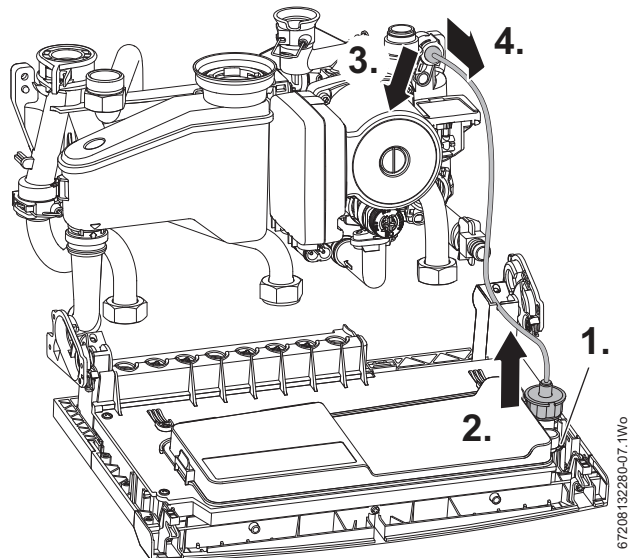

67208132280-07.1W0

Fig. 103 Pressure gauge removal

7.8.19 BOILER RETURN SENSOR (NTC)

- ▶ Isolate the boiler and ensure that the system is fully drained.
- 1. Withdraw the spring clip to release the sensor.
- 2. Pull the sensor down to remove from the housing.
- ▶ To refit follow the above actions in reverse.

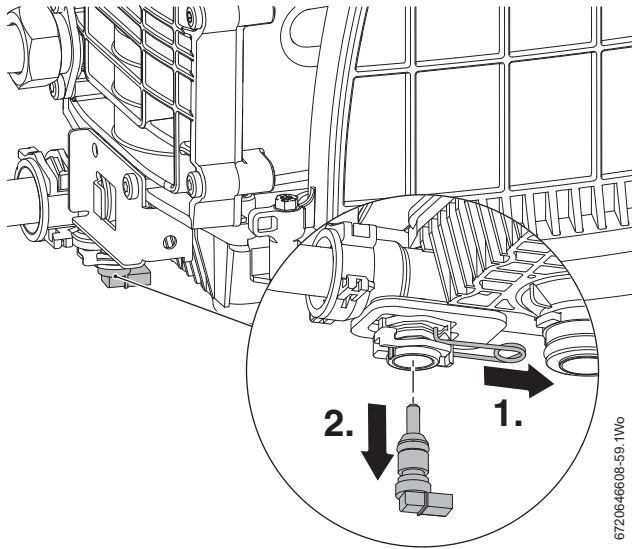

Fig. 104 Boiler return sensor

7.8.20 DRAIN TAP

- ▶ Ensure that the system is full drained down.
- ▶ The drain tap rotates anti-clockwise for a ¼ turn to open.
- 1. Rotate the drain tap anti-clockwise passed the ¼ turn stop point to release.
- 2. Push in and withdraw from the housing.

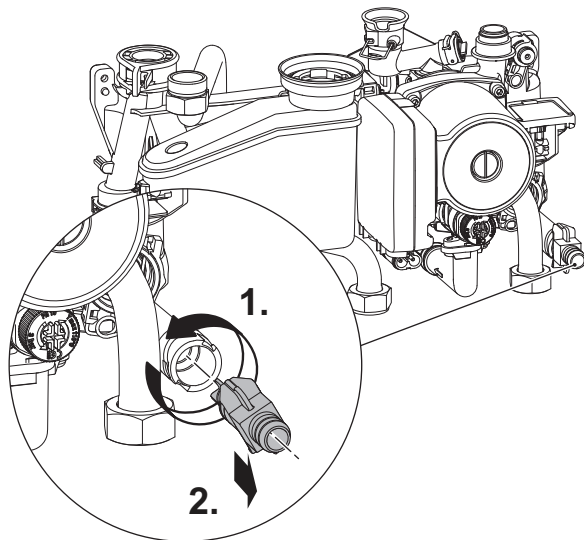

Fig. 105 Drain tap

7.8.21 CH PRESSURE RELIEF VALVE

- ▶ Isolate the boiler and ensure that the boiler is fully drained.
- 1. Release the knurled connector from the bottom of the PRV.
- 2. Pull the captive clip to the left to release the PRV.
- 3. Pull the Central Heating pressure relief valve out of the housing.
- ▶ Replace in reverse order, secure with the clip and mounting screws.

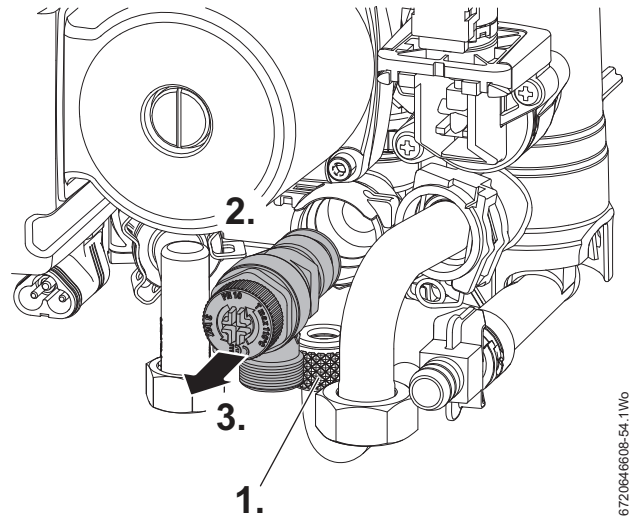

Fig. 106 PRV

7.8.22 HYDRAULIC BLOCK REMOVAL



Do not remove the hydraulic block assembly unless absolutely necessary.

Before removal:

- ▶ Isolate the electrical power to the boiler.
- ▶ Drain the system.

1. Squeeze the ratchet connector and rotate clockwise to release.
2. Release the clip on the expansion vessel connector at the pump assembly.
3. Pull the expansion vessel up and secure in raised position.
4. Remove the clip securing the pump return to the heat exchanger.
5. Remove the two screws securing the CH pressure relief valve mounting.
6. Remove the screws securing the hydraulic block assembly.

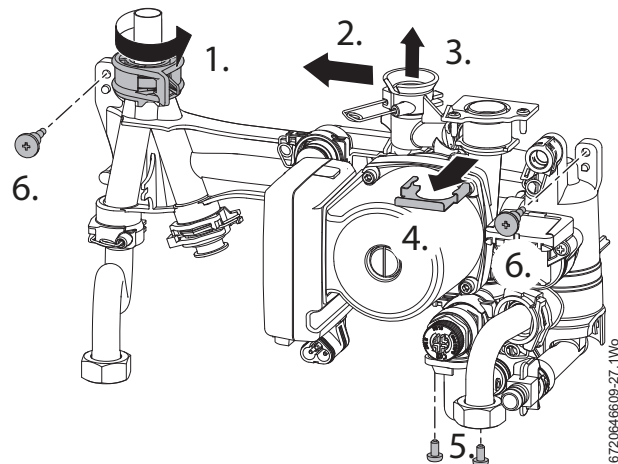

Fig. 107 Hydraulic block

7.8.23 BYPASS VALVE

Remove the hydraulic block from the boiler, refer to section 7.8.22.

1. Remove the clip on the return connection.
2. Remove the clip on the pump connection.
3. Remove the spring clip retaining the copper by-pass pipe.
4. Separate the return unit from the flow manifold assembly.
5. Using a pair of pliers remove the by-pass valve.

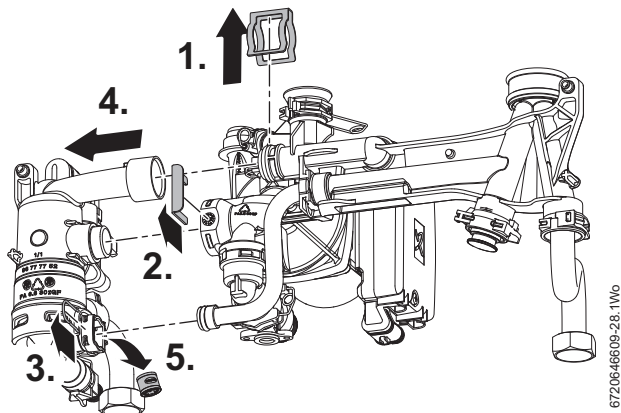

Fig. 108

► When re-assembling, in reverse order, ensure that any seals that have been disturbed are replaced.

7.8.24 ACCESS TO BOILER CONTROL COMPONENTS

1. Remove the three screws retaining the installer access cover.
2. The access cover can now be removed with the flap.

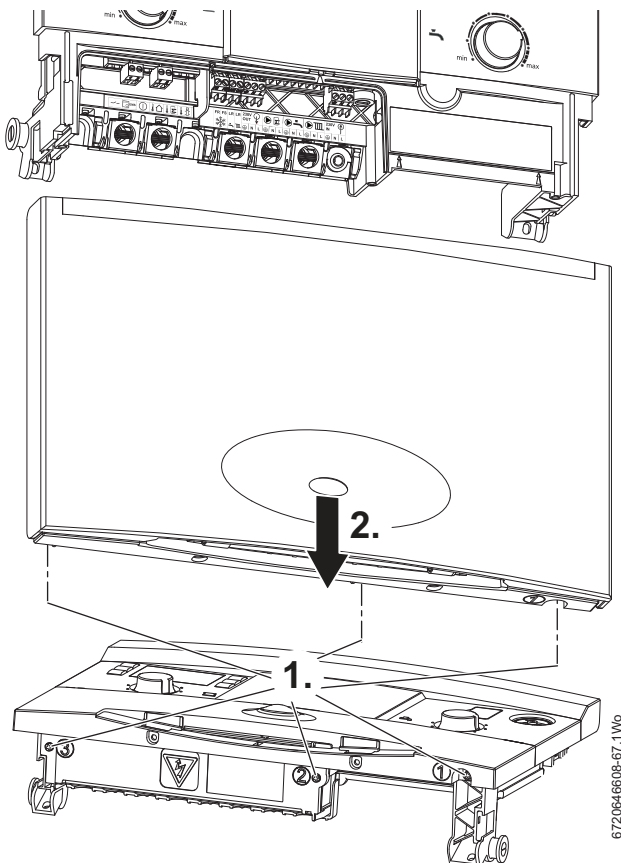

Fig. 109 Installer access cover

PCB FUSE

The fuse is located next to the high voltage connectors and the spare fuse (1) is located on the back of the access cover.

To remove the fuse:

1. Push the top of the fuse holder up.
2. Rotate the top of the fuse holder anti-clockwise and remove.

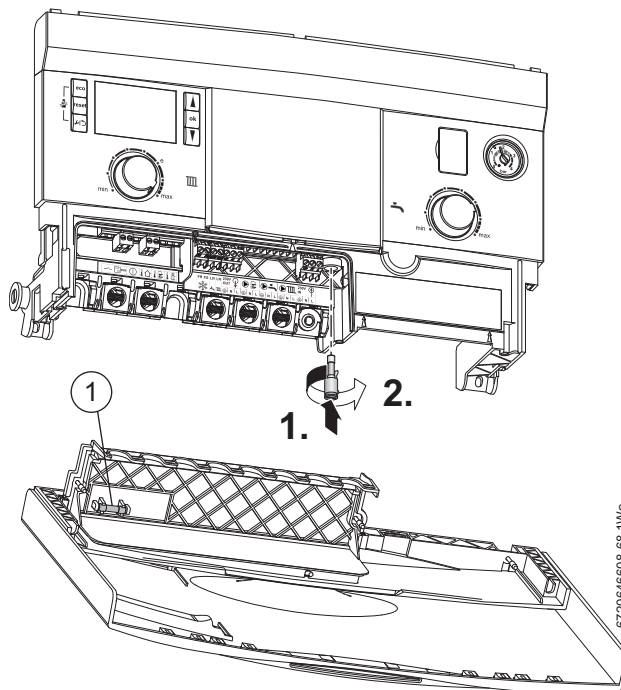

Fig. 110 Fuse holder

7.8.25 REPLACING THE CONTROL UNIT



The control unit is supplied within a plastic housing. The complete unit must be replaced.

With the installer access cover removed:

1. Remove all the connectors
2. Slide out all the cable strain relief clamps

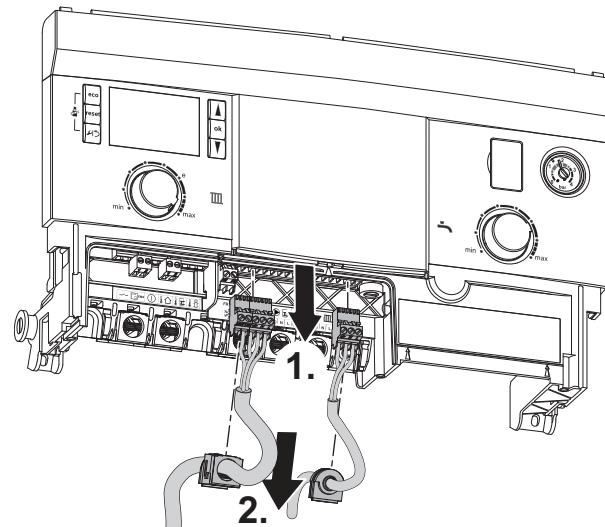

Fig. 111 Disconnect external connections

With the control unit in the service position:

1. Remove the access cover retaining screw.
 2. Release the catches and remove the access cover.
- ▶ Disconnect and remove all cables and connectors from the control unit.
 - ▶ Remove the pressure gauge, refer to section 7.8.18.

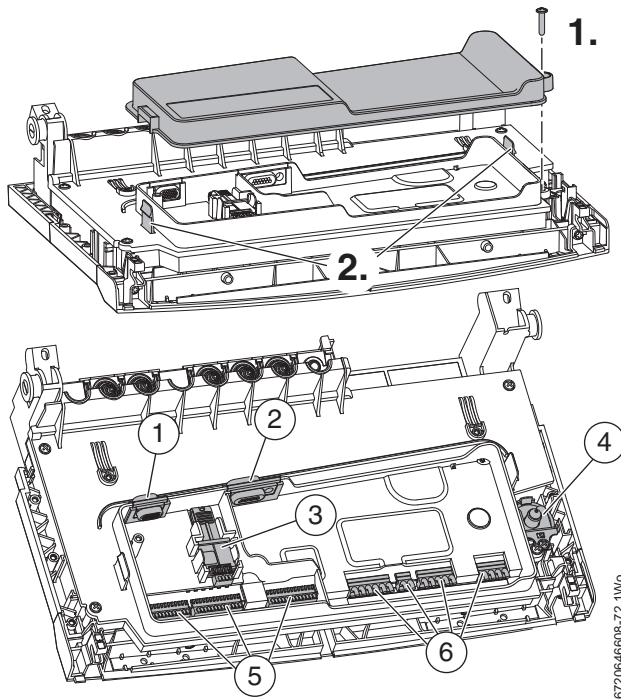
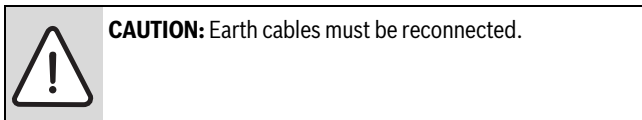

Fig. 112 Access to the cables

- [1] Low voltage cable inlet
- [2] Mains voltage cable inlet
- [3] HCM - Heating Control Module
- [4] Pressure gauge
- [5] Low voltage connectors
- [6] Mains voltage and earth connectors

REMOVING THE CONTROL UNIT

- ▶ Support the control unit and detach the control unit support strap.
1. Remove the hinge locking pieces.
 2. Release the two catches underneath the panel.
 3. Hinge the control unit up to approximately 45°.
 4. Push inwards and upwards to disengage the control unit from the hinge supports.
- ▶ Remove the support strap from the control unit.
 - ▶ Fit the new control unit in the reverse order.
 - ▶ Attach support strap to the new control unit.
 - ▶ Reconnect all the cables previously disconnected under the access cover.



- ▶ Replace the access cover and secure with the screw.
- ▶ Reconnect the cables previously disconnected under the installer access cover.
- ▶ Replace the installer access cover and secure with the three screws removed earlier.

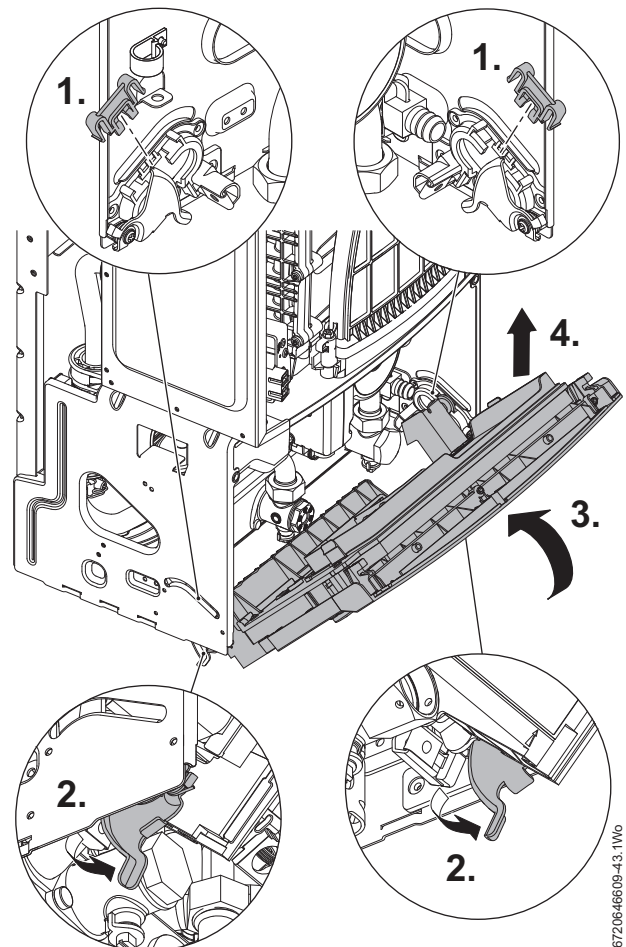

Fig. 113 Removing the controller

7.8.26 EXPANSION VESSEL

The expansion vessel can be replaced with the boiler in place if there is a side exit flue fitted and a minimum clearance of 450mm above the boiler casing.

If a vertical flue is fitted then a similar clearance to one side of the flue is required.

If the clearance is not available, then the boiler will need to be removed from the mounting frame to gain access to the expansion vessel.

Alternatively a second vessel of at least the capacity of seven litres can be fitted to the return pipe from the heating system as close as possible to the boiler.

EXPANSION VESSEL REPLACEMENT (BOILER IN PLACE)

- ▶ Isolate the power from the boiler.
- ▶ Lower the control panel into the service position.
- ▶ Isolate the boiler from the heating system using the service valves.
- ▶ Drain the boiler.
- ▶ At the pump manifold, release the clip and disconnect the expansion vessel.
- ▶ Pull the vessel up and out over the flue system or to one side if a vertical flue is fitted.
- ▶ Fit a new "O" ring (supplied in the spares kit) to the replacement vessel
- ▶ Reassemble the expansion vessel into the wall frame and slide down the runners until the end pipe is reconnected into the pump manifold.
- ▶ Secure the pipe with spring clip.

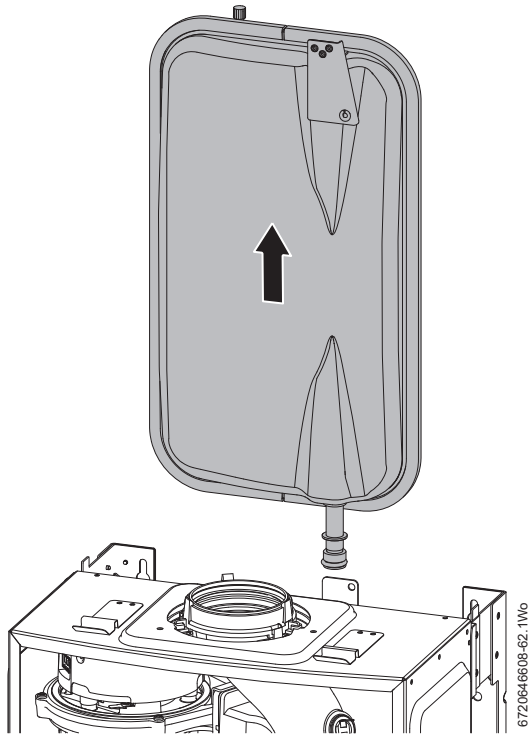

Fig. 114

EXPANSION VESSEL REPLACEMENT (REMOVE BOILER)

- ▶ Isolate the power from the boiler.
 - ▶ Isolate the systems and gas connection using the service valves.
 - ▶ Drain the boiler.
 - ▶ Disconnect the electrical supply and any external controls.
 - ▶ Disconnect the flue from the boiler.
 - ▶ Undo the connections to the boiler at the service valves.
 - ▶ Lower the control panel into the service position.
 - ▶ At the pump manifold, release the clip and disconnect the expansion vessel.
 - ▶ Lift the expansion vessel up to clear the pump manifold connection.
 - ▶ Secure the expansion vessel to the wall frame by the bracket at the top.
 - ▶ Undo the two screws at the bottom of the case.
 - ▶ Release the clips at the top of the case and slide the case towards you to remove.
 - ▶ Disconnect the pipes and syphon discharge hose from the plumbing manifold.
 - ▶ Lift the boiler off the wall frame.
1. Remove the screw retaining the expansion vessel to the wall frame.
 2. Remove the screw securing the right hand expansion vessel mount.
 3. Slide the mount to the right to release the expansion vessel.
 4. Pull the expansion vessel towards you.
 5. Pull the expansion vessel down to remove.

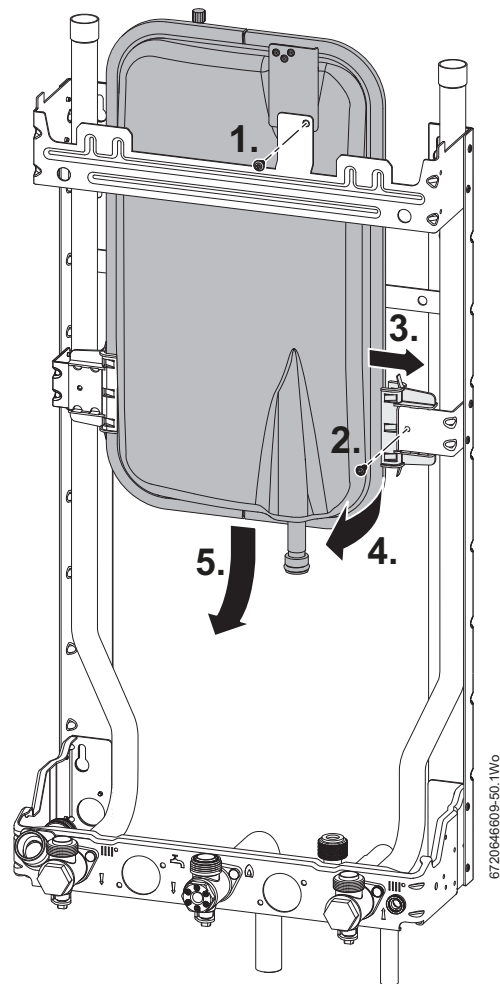

Fig. 115 Removing the expansion vessel

- ▶ Replace the expansion vessel in the reverse order.
- ▶ Ensure that the expansion vessel is fixed in the upper position.
- ▶ Follow the procedures in this manual for commissioning this product.

7.9 SHORT PARTS LIST



	Fan 8 716 117 417		Burner 8 718 600 23B 0		Gas Valve 8 718 600 04A 0
	Control panel 8 737 909 49A 0		Flue overheat thermostat (grommet type) 8 717 206 213 0		Electrodes (including gasket) 8 718 600 28A 0
	Burner seal 8 718 600 24A 0		Spark generator 8 716 117 077		Pump assembly 8 716 117 628
	Flow NTC 8 718 688 801 0		Diverter valve assembly 8 716 106 845 0		Auto Air Vent T 005 000 87A 0
	Pressure gauge 8 718 686 513 0		Diverter valve motor 8 718 682 839 0		Maximum safety sensor NTC 8 718 685 483 0
	By pass valve 8 716 106 434 0		Expansion vessel 8 718 684 945 0		Pressure relief valve 3 bar 8 718 681 163 0
	Return temperature sensor - (NTC) 8 718 684 323 0		Air Pressure Switch 8 716 106 633 0		

Table 30 Short parts list

8 FAULT FINDING AND DIAGNOSIS

8.1 INTERNAL WIRING DIAGRAM

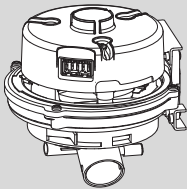
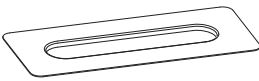
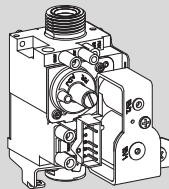
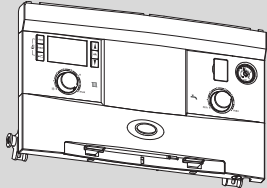
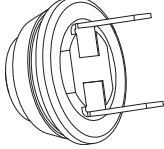
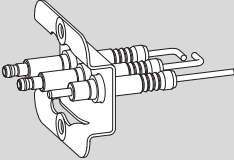
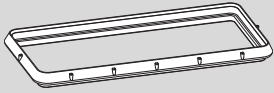
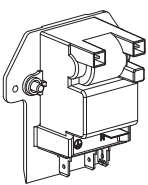
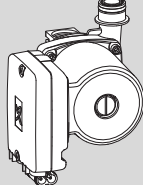
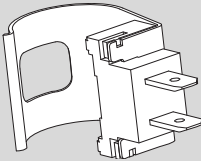
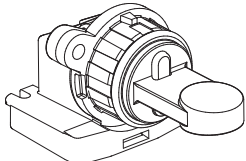
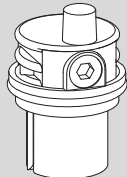
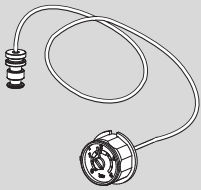
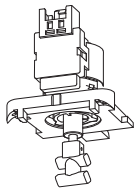
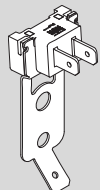
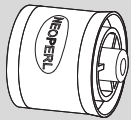

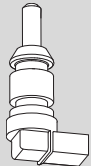
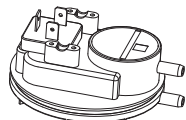
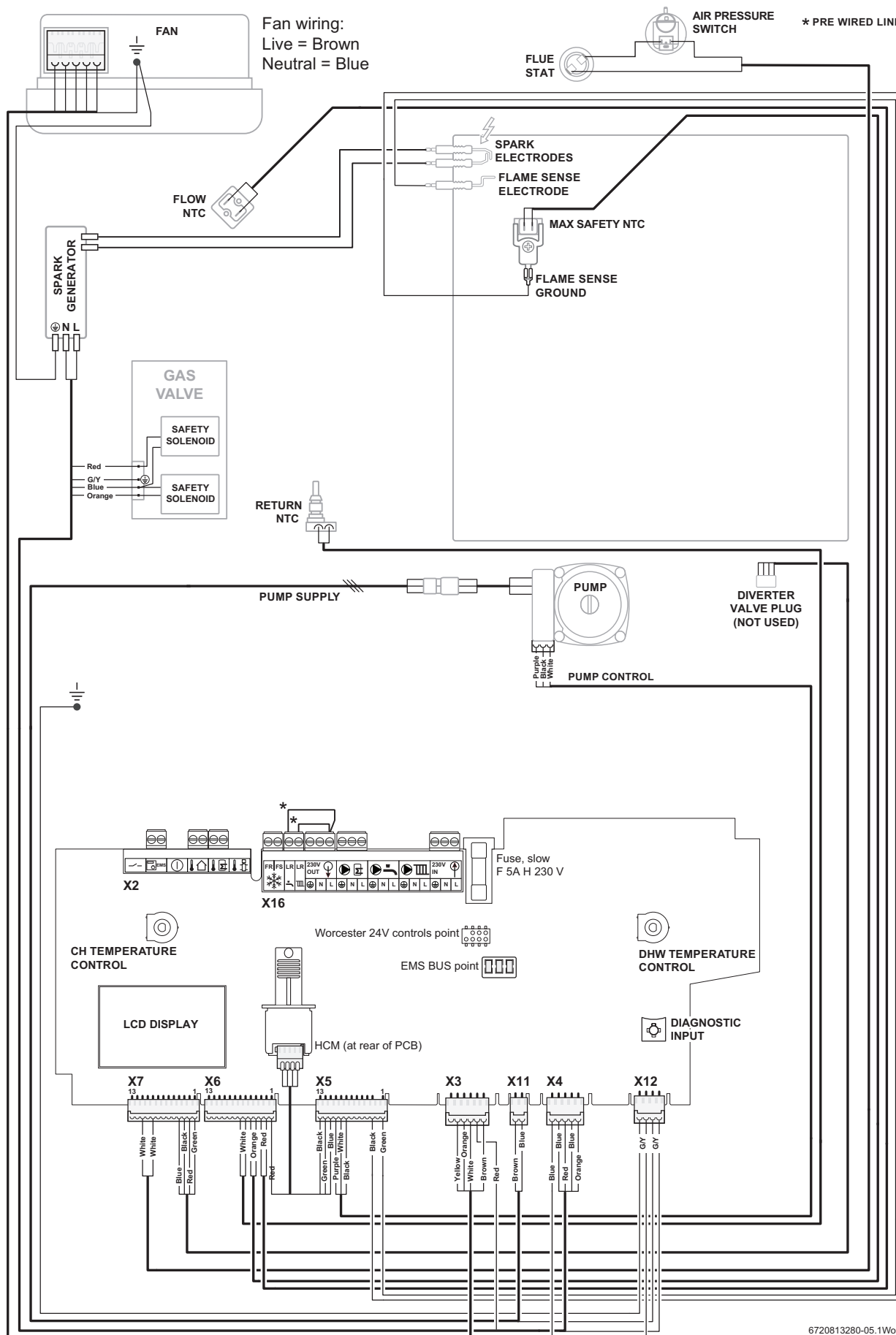
8.2 HEATING FUNCTION

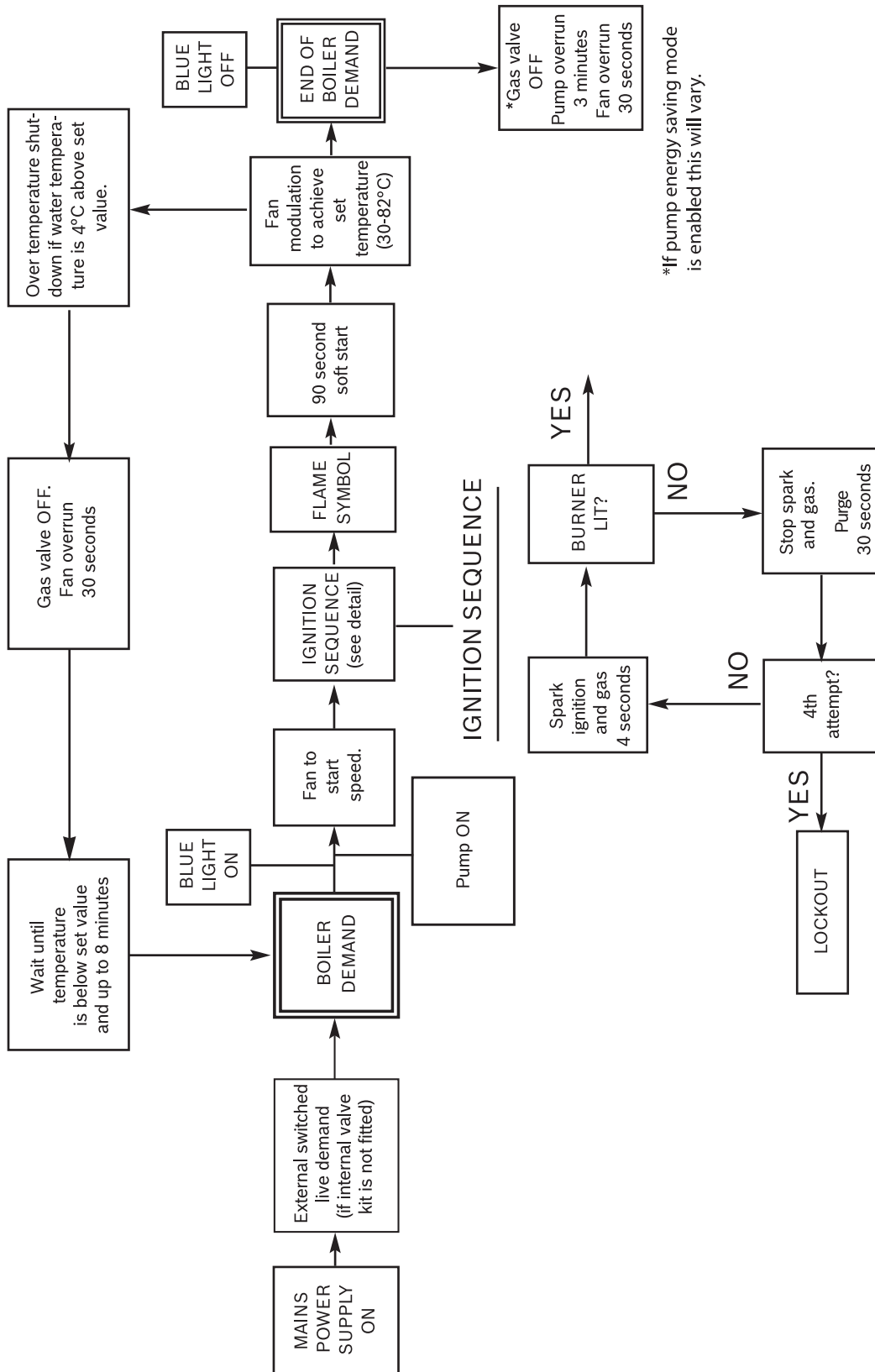

6720813280-06.1Wo

Fig. 116 Heating function

8.3 PROTECTION FUNCTIONS

AUTOMATIC INTERNAL FROST FUNCTION

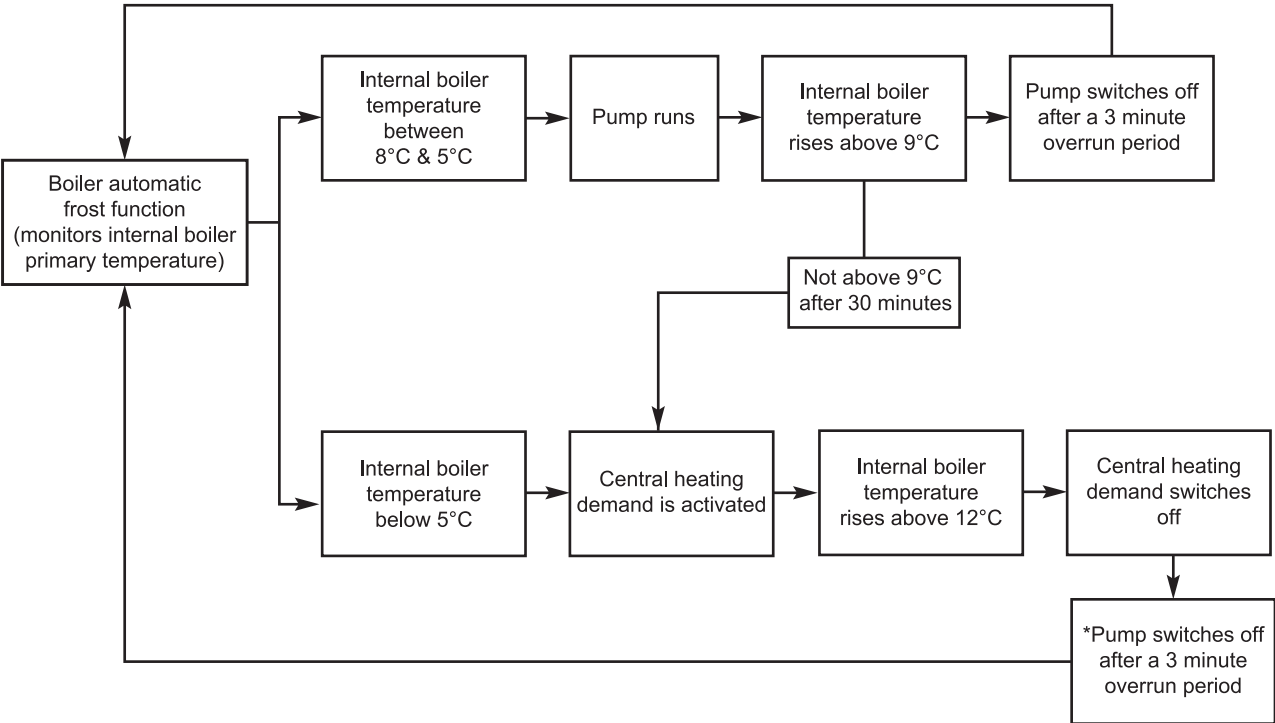

PUMP OVERRUN FUNCTION

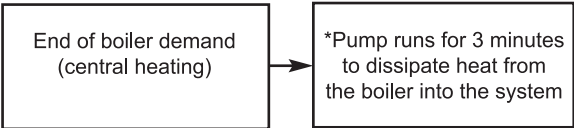

PUMP OVERRUN LOCKING ERROR

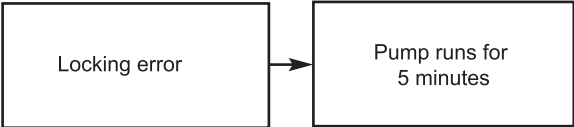

* This may vary if the Pump Energy Saving mode is enabled

PUMP ANTISEIZE FUNCTION

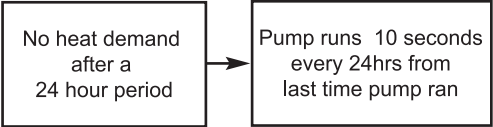



Fig. 117 Protection function

6720807726-03.1Wo

8.4 INFORMATION AND SERVICE MENUS

STATUS CODES

During normal boiler operation various Status codes can be displayed by pressing the  button.

The first screen of the Information menu displays the current Status code, this will change as the boiler runs through the various modes and sequences.

These are not always faults, but just provide information concerning the current status of the boiler.

Status codes	Fault codes	
200		CH System is being heated
201		DHW system is being heated
202		Anti rapid cycle mode for CH
203		System stand by
204		System waiting, primary flow temperature above setpoint
205		Waiting for airflow
207	CE	System pressure too low
208		Test mode active due chimney switch
210	E9	Flue-gas thermostat or Air pressure switch activated
211		TTB opened (thermal kickback device)
212		Safety or flow temperature rises too fast
213	D4	Temperature difference between supply and return exceeding limit
214	C7	Fan not running
215	C6	Fan running too fast
216	C6	Fan running too slow
217	C7	No airflow after defined period of time
218	E5	Flow temperature too high
219	E9	Safety sensor temperature too high
220	E9	Safety sensor shorted
221	E9	Safety sensor disconnected
222	E2	Flow sensor shorted
223	E2	Flow sensor disconnected
224	E9	MAX thermostat activated
225		Difference between flow and safety exceeding limit (bi-sensor only)
227	EA	No ionisation detected after ignition
228	F7	Ionisation current detected before burner-start
229	EA	Loss of ionisation signal during operation
230	EA	Ionisation signal out of bounds
231	FD	Mains power error - electrical power interruption
232	D3	external cut-off switch activated
233	9U	HCM problem
234	EA	Gas valve coil disconnected
237	C4	Airflow present during last 24 hours - fan running continuously
238	F0	Internal error - replace control board
239	F0	Watchdog relay error
240	D1	Return sensor shorted
241	D1	Return sensor disconnected
242 to 256	F0	Internal error call Bosch help line 0330 123 3366
257	b7	Internal error - replace control board
258 & 259	F0	Internal error call Bosch help line 0330 123 3366
260		No temperature rise after burner start

Status codes	Fault codes	
261	EA	First Safety timing error
262 & 263	F0	Internal error call Bosch help line 0330 123 3366
264	C1	Airflow stopped during operation
265		Stand-by mode forced due to energy transfer limit
266	CE	No pressure variation detected after switching pump
267	F0	Watchdog time-out error
268		Component test mode
269	EA	Ignition device activated too long
270		Power up mode
271	D4	Temperature difference between flow and safety sensor exceeding limit
272	F0	Internal error
273	C4	Airflow present during last 24 hours
274		Ionisation signal present during last 24 hours
276	E9	Flow temperature exceeded 95°
277	E9	Safety sensor temperature exceeded 95°
278	F0	Sensor test failed
279	F0	AD converter error, unstable measurement
280	F0	Recycle timing error
281	A1	Pump stuck or running in air
282	H5	No feedback from pump
283		Burner starting
284		Gas valve(s) opened, first safety time started
285	E9	Return temperature exceeded 95°C
286	D1	Return temperature too high
287	F0	Ionisation sensor shorted
288	CF	Water pressure sensor not connected or short-circuit to supply
289	CF	Water pressure sensor not connected or short-circuit to ground
290	F0	AD converter reference error
305		Anti fast cycle mode for DHW
306	FA	Ionisation detected after burner stop
307		Pump stuck
308		Pump running in air
309		CH & DHW system are being heated
310		CUS communication error
311		CUS locked
312		CUS blocked
313		CUS reported error condition
314		Mains disconnected during super lockout
315		Several times lack of water flow
316	E9	Flue gas sensor temperature too high
317	A3	Flue gas sensor shorted
318	E9	Flue gas sensor disconnected
321		Self-test of flue gas supervision
322		Code error
323	A8	EMS communication error
324		DHW-NTC defect
325		DHW-NTC not correctly installed
326		Storage-NTC defect
327		Reset-key stuck or short-circuit
328		Internal error

Status codes	Fault codes	
329	CE	No pressure variation detected after switching pump
332	E5	Supply sensor exceeded 110°C
333		Start temporarily not allowed due to flow error on CH
338	F0	Too many short burner starts without confirmation of water flow
341	D4	CH: supply and/or return temperatures rising too fast
342	D4	HW: supply temperature rising too fast
343	ED	CH: flue gas temperature rising but supply temperature not
344	ED	HW: flue gas temperature rising but supply temperature not
345	EF	Supply and/or return temperatures do not change after burner start
346	EC	Flue gas temperature rising too fast
347	E3	Return temperature higher than supply temperature (some time after burner start)
348	EE	HW: supply temperature too hot
349	EF	CH: Boil Detect, large delta T despite minimum burner load
350	E2	Flow sensor shorted 351 'E2' Flow sensor disconnected
353	--	Burn temporarily blocked due to no 20 minute continuous OFF time in last 24 hours.
354		Overpressure setting erased
357		Primary Heat Exchanger air venting program active - approx. 100 seconds
358		Three way valve kick
359		DHW outlet temperature too hot
364	FA	Gas valve EV2 leak test failed
365	Fb	Gas valve EV1 leak test failed
372		Temporarily ignoring CH requests to limit temperatures of the appliance components
373	8C	Super-Lock caused by too frequent thermostat overheat detections during burning
374	8C	Super-Lock caused by too frequent ionisation loss during burning
375	E4	Preheat sensor on DHW inlet Short Circuit
376	E4	Preheat sensor on DHW Inlet Open Circuit
380		Inlet temperature greater than DHW Outlet Set point
800	CC	Outdoor sensor defect
808	A7	Domestic hot water sensor defect
810		Domestic hot water remains cold
828		Water pressure sensor defect





8.4.1 SELECTING THE INFORMATION MENU

The Information Menu is a "read only" menu. Information about the boiler is displayed here, some of the values are updated in real time to give the current status of the boiler.

All menus time-out after two minutes and the display returns to the normal operation display, the display backlight turns off after another 30 seconds and goes into stand-by mode.

Double up or down arrows indicate that the menu can only be scrolled up or down, an up and down arrow combination indicates position in the menu where options can be scrolled either up or down.

To enter Information menu:

1. Press the  button to enter the information menu.
 - ▶ A three figure boiler status code will be displayed along side the information menu number. Refer to table 35 for a description of the boiler status codes.
2. Use the  and  arrow buttons to scroll through the menu items.
 - ▶ Press the  button again to exit the Information menu.

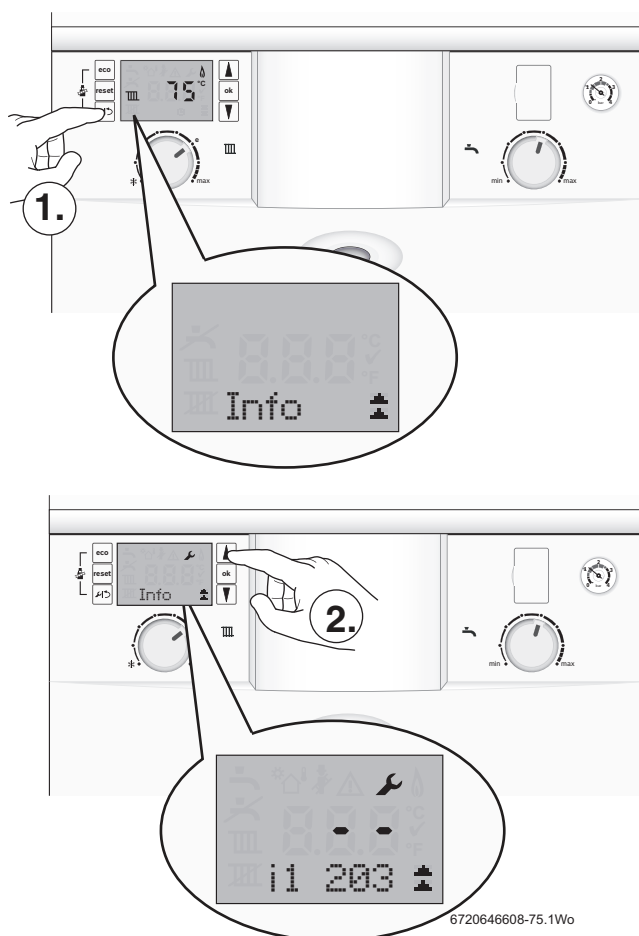

Fig. 118 Accessing the Information menu

i01	Current status	Every operation and mode of the boiler has a related boiler status code. The boiler status code is displayed on the screen as a three figure number. Refer to table 35 for information on the boiler status codes.
i02	Last error	This can be viewed during normal operation. Displays the last diagnostic code with boiler status code.
i04	* Maximum heating output	The maximum possible DHW heat output is displayed in kW. The boiler may have the maximum output reduced via Menu 3.1B
i08	Ionization current	The ionization current should be equal to or greater than 35 μ Amps, with the boiler at maximum rate.
i09	Flow temperature	This is the actual temperature from the main heat exchanger displayed in real time.
i10	Maximum temperature	This is the current temperature from the "Maximum safety sensor". This sensor is mounted on the front of the heat exchanger.
i13	* Storage temperature	The current temperature from the hot water cylinder sensor.
i14	Return temperature	The current temperature returned to the main heat exchanger.
i15	* Outdoor temperature	Optional outdoor temperature sensor needs to be connected, used in conjunction with the optional integral diverter valve kit for this menu to be activated.
i20	Software version	Firmware version of the main control board.
i21	Software version	Firmware version of the fascia control display board
i22	Heat Control Module (HCM) no.	The last three digits of the HCM are displayed: 594 = 27kW Ext. System NG 595 = 27kW Ext. System L.P.G. 598 = 27kW Int. System NG 599 = 27kW Int. System L.P.G. 592 = 30kW Ext. System NG 593 = 30kW Ext. System LPG 596 = 30kW Int. System NG 597 = 30kW Int. System LPG
i23	Heat Control Module (HCM) version.	Firmware version of the HCM

* Only available when the optional integral diverter valve kit is installed

Table 31 Information menu listing

8.4.2 SELECTING SERVICE MENUS

1. Press and hold and buttons together for one second, the display will show Menu 1.

Double up or down arrows indicate that the menu can only be scrolled up or down, an up and down arrow combination indicates position in the menu where options can be scrolled either up or down.

2. Scroll up and down through the menus with the and buttons on the right hand side of display.

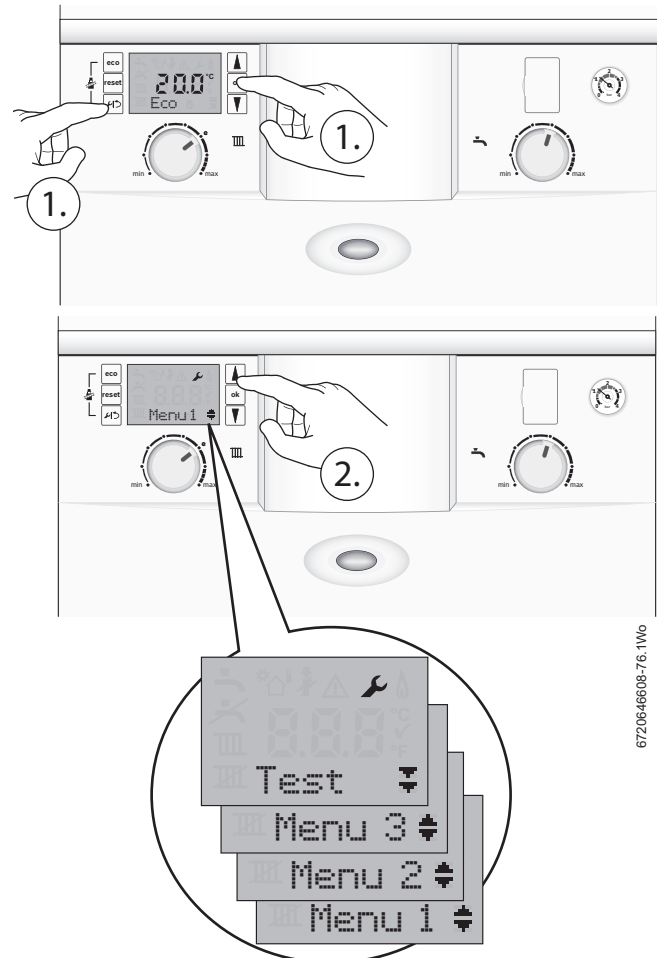

6720646608-76-1W6

Fig. 119 Service menu selection

8.4.3 MENU 1 - SYSTEM PARAMETERS

Initially Menu 1 will be displayed, but will contain no options.

Menu 1 options will appear on the display when the Intelligent Solar Module ISM1 is installed on the Greenstar i System Compact ^{EP} range only.

8.4.4 MENU 2 - BOILER PARAMETERS

1. Select Menu 2 via the and scroll buttons.
2. Press and hold the button for one second to enter Menu 2.

This menu lists the boiler parameters, which can be adjusted in this menu.

To modify a setting, select the desired menu option (refer to table 32) and press the button, the option will flash.

Adjust the parameter using the and arrow buttons and press the button to confirm.

A will display for three seconds to confirm the update of the new value.

The same process is used for adjusting Menus 2, 3 and Test.

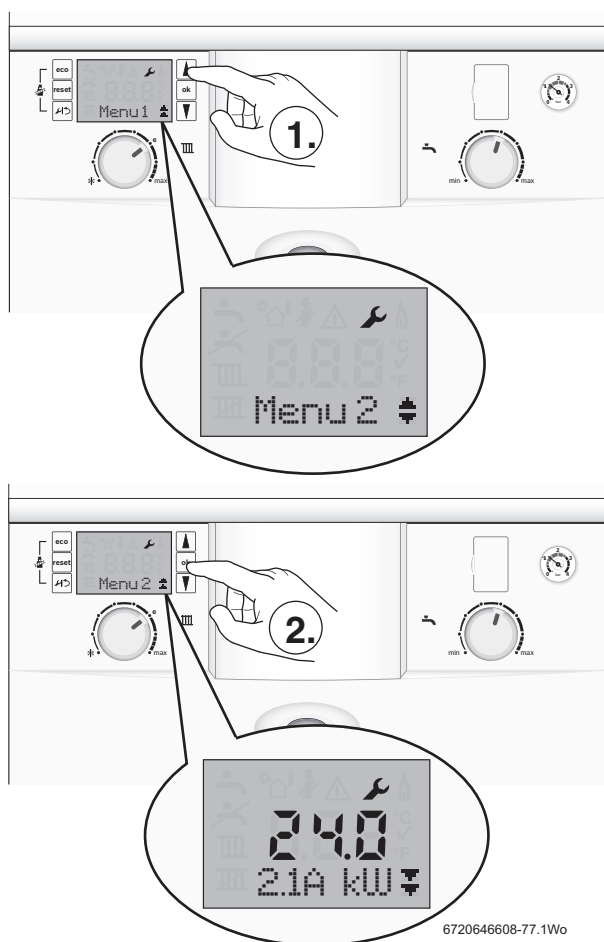

Fig. 120 Menu 2 selection

*2.1b	Maximum power for DHW	The power for the DHW can be set here up the maximum set in menu 3.1b
2.1C	Pump head selection	Select the right pump map (load and modulation percentage) to suit the property. 0 = Variable speed setting (see 2.1d) 1 to 4 option pump maps.

Table 32 Menu 2 parameters

2.1d	Pump speed setting	This function is only available when parameter 2.1C is set to 0. 1 = Min. and Max. speed can be changed manually 2 - 7 = Constant speeds 8 - 10 = Predefined min. and max. settings (speed depends on burner load)
2.1E	Pump energy saving mode	4 = ON 5 = OFF
2.1H	Minimum pump speed (pump speed at minimum CH burner load)	This parameter is only visible when 2.1C is set to 0 and 2.1d is set to 1. Then the minimum pump speed can be set.
2.1J	Maximum pump speed (pump speed at maximum burner load)	This parameter is only visible when 2.1C is set to 0 and 2.1D is set to 1. Then the maximum pump speed can be set.
*2.2C	Air purge mode	This feature can be selected to purge the system and boiler of air. 0 = off, 1 = auto
2.3B	Anti fast cycle time for CH	This sets the amount of time between stop and starts of the main heat exchanger. The default is 10 minutes, the range is 0 to 60 minutes.
2.3C	Anti fast cycle flow temperature hysteresis (negative tolerance only)	This sets the temperature drop before the burner re-starts, 6°K is the default. This is used in conjunction with the "Anti fast cycle time" The range is from 2 to 15°K in 1°K steps.
2.5F	Service reminder time	Between 1 and 72 months can be set
2.7A	Operation/fault indicator (blue light) activation	0 = The blue light will only operate as a flashing alert. 1 = The blue light will operate as a boiler operation and an alert. This is set to 1 by default.
*2.9L	Anti Legionella program	This feature can be selected to force a thermal disinfection. 0 = off, 1 = on
*2.2J	Alternating mode ON/OFF	This feature allows the CH and DHW load to be shared equally, under normal boiler operation the DHW takes priority. 0 = off, 1 = on
2.CE	DHW circulating pump number of starts/hour	1 - 6 number of 3 minutes starts per hour. 7 - Continuous running
2.CL	DHW circulating pump, ON/OFF	This feature, when set to 1 enables any additional pumps within the system to run at the same time as the main boiler pump. 0 = No circulation pump installed. 1 = DHW circulation pump installed and controlled according to parameter 2.CEon

* Only available when the optional integral diverter valve kit is installed

Table 32 Menu 2 parameters

8.4.5 RESET TO FACTORY SETTINGS

To reset any or all changes made in menu 2 back to the factory defaults setting:

NOTICE: Menu 3
▶ Any changes made in Menu 3 are not reset via these actions.

1. Press and hold the , and arrow button for at least five seconds.
The screen will then display code 8E with the spanner symbol.
2. Press the button and "Reset" will be displayed with the tick symbol for three seconds.
After three seconds the screen will revert to the normal operation screen.

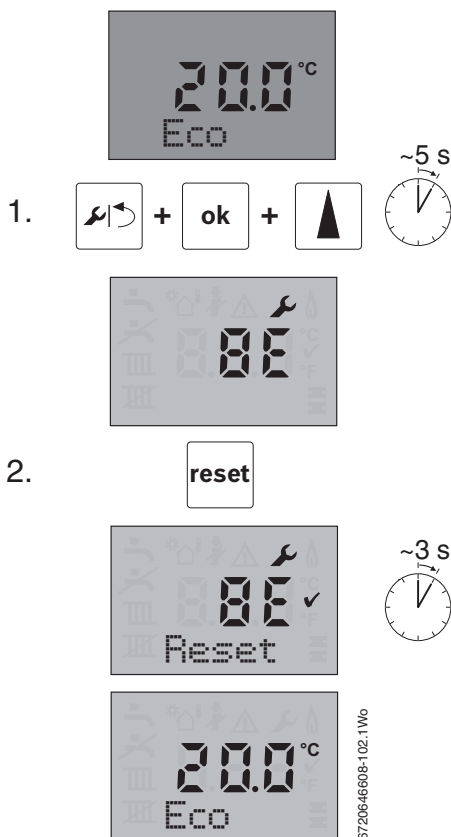

Fig. 121 Reset sequence

8.4.6 MENU 3 - BOILER MAXIMUM & MINIMUM LIMITS

The menu shows the boiler's minimum and maximum limits. They can be adjusted in this menu.

The boiler will revert to adjusted settings in Menu 3 following a power interruption.

Menu 3 cannot be factory re-set.

1. Select menu 3 via the and scroll buttons.
2. Press and hold the button for at least 5 seconds to enter Menu 3.

To modify a setting, select desired menu option (refer to table 33) via the and arrow buttons and press the OK button, the option will flash.

Adjust the parameters using the and arrow buttons and press the OK button to confirm.

A symbol will be displayed for three seconds to confirm the update of the new value.

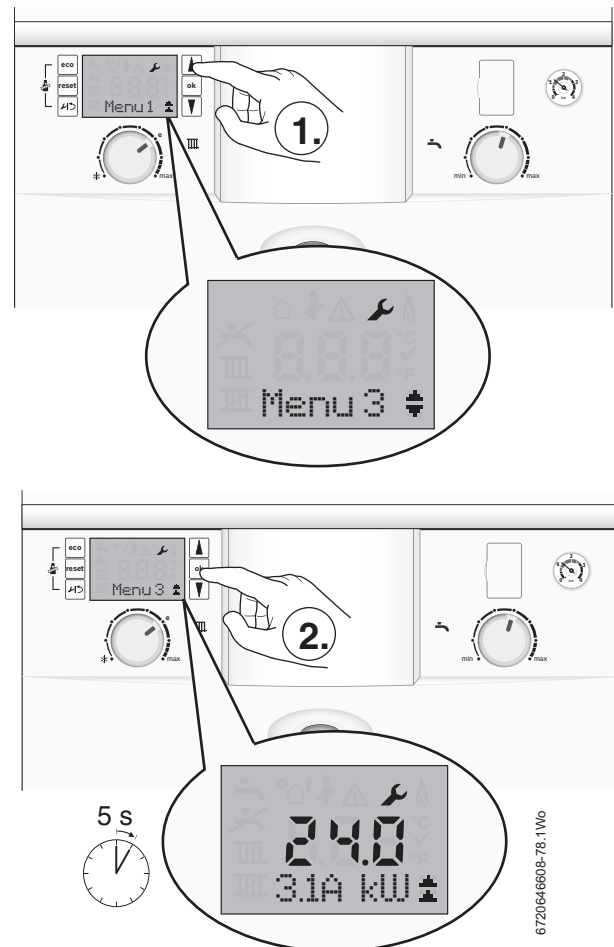

Fig. 122 Menu 3 selection

3.1B	* Maximum DHW heating output	The maximum DHW heating output in kW can be set here. The output can be down rated.
3.3D	Minimum boiler power for both heating and hot water.	This sets the minimum output, for example 7kW.

* Only available when the optional integral diverter valve kit is installed.

Table 33 Menu 3 parameters

8.4.7 USING THE TEST MENU

This menu enables the testing of the functionality of components in an ON/OFF mode. The duration of each test is limited to 30 seconds.

1. Select menu TEST via the ▲ and ▼ scroll buttons.
2. Press the button for one second to enter TEST.

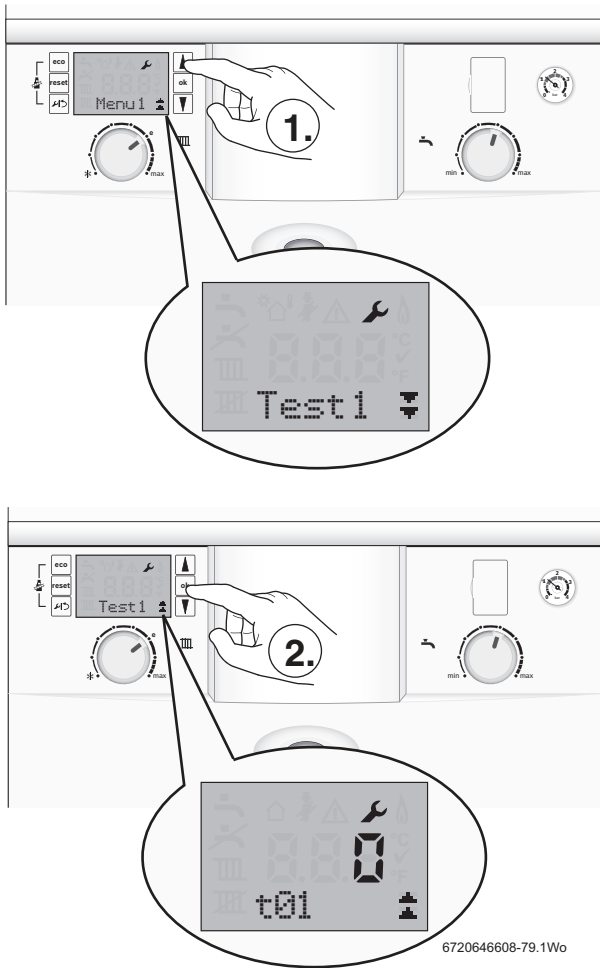

Fig. 123 Selecting test menu

SELECTING A TEST COMPONENT

Refer to table 34 and use the ▲ and ▼ arrow buttons to scroll through the various test options.

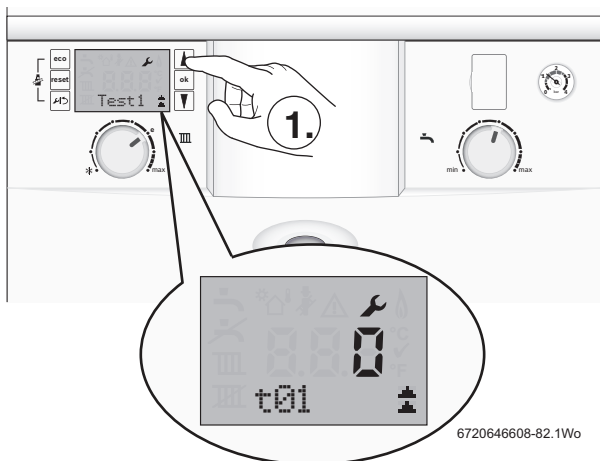

Fig. 124 Scroll through test options

TESTING THE COMPONENT

- ▶ Select a component to test.
- ▶ Press the button, the value 0 will flash.
- ▶ Use the ▲ arrow button to change the value to a flashing 1.
- ▶ Press to confirm the change, the value 1 will stop flashing and a ✓ will displayed for 3 seconds.

The test will run for 30 seconds or until the value is changed back to 0.

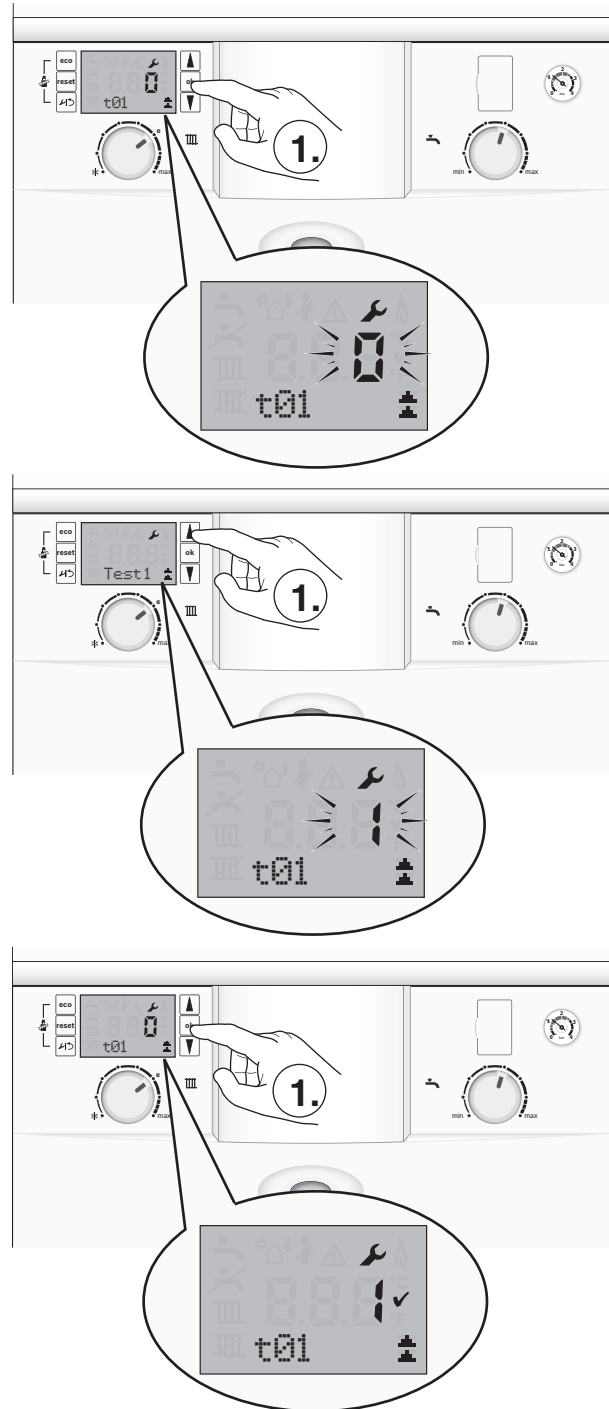

Fig. 125 Testing component

RESETTING THE TEST COMPONENT

After completing the test:

- ▶ Press the **ok** button, the value 1 will flash.
- ▶ Press the **▼** arrow button, the value will change to a flashing 0.
- ▶ Press **ok** to confirm the change, a **✓** will displayed for 3 seconds.

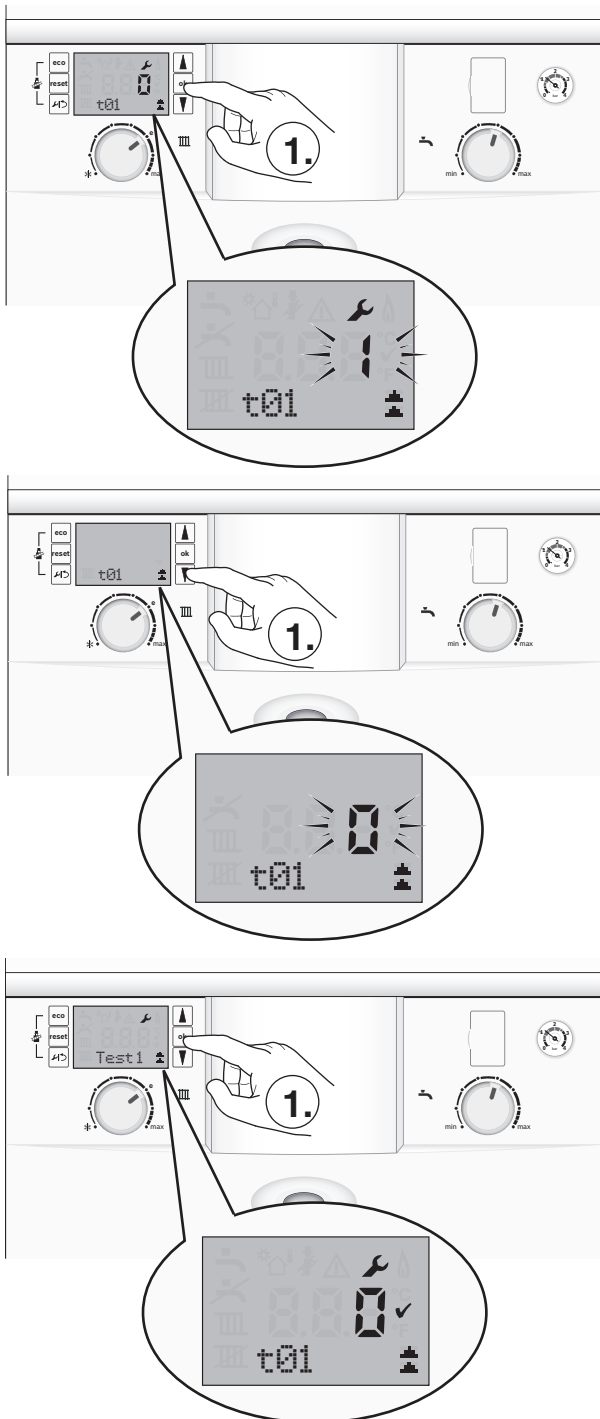

Fig. 126 Resetting test

Test		
t1	Igniter test. Checking the igniter spark.	The igniter will spark for a maximum of 30 seconds. The spark will be audible if the igniter is OK.
t2	Fan test. Checking the basic fan operation.	The fan will run for a maximum of 30 seconds. If the fan is OK then the fan will be heard running.
t3	Pump test. Checking the basic pump operation.	The pump will run for a maximum of 30 seconds. If the pump is OK then the pump will be heard running.
t4	Three way valve test*. Test the operation of the diverter valve.	When 1 is selected via the test menu the diverter valve will move to the DHW position. When 0 is selected the valve will move to CH position.
t6	Ionisation oscillator test. Tests the flame detection circuit.	Ionisation circuit is switched on. Approximately 150 Volts a.c. can be measured between the ionisation probe and earth.

* Only available when the optional integral diverter valve kit is installed.

Table 34 Test menu

8.5 FAULT CODES

Should a fault develop with this boiler (or the system), the boiler will enter a locking or blocking condition, and fault code information will be generated as described in this section.

Locking error	The boiler display will flash a warning triangle and fault code. At the same time a (static) cause code will also be displayed. Manual intervention is required following clearance of the fault: ▶ Press the reset button on the boiler fascia
Blocking error	The boiler will stop operating with no fault data displayed. The cause code, in the info menu, is accessed by pressing the spanner/return button. The condition will clear automatically when the associated fault clears e.g. waiting for an area to cool. In some cases a blocking error has a defined time duration prior to changing to a locking condition.
Fault code	Alpha numeric code indicating the fault group
Cause code	Three digit number. During a blocking error (or normal operating status) it is not displayed, but accessed in the info menu via the spanner/return button. During a locking error the cause code flashes on the display.
Maintenance codes	These are displayed with the letter H followed by a number. The code advises of a situation that will need some attention but is not a fault that will stop the boiler from functioning. Some of the common ones are listed: H11 Hot water outlet sensor defect, hot water can still be delivered but with less control (sensor open/short circuit or out of position) H13 A time has been set in the Service interval function i.e. 1 to 72 months and that time has expired. Menu 2.5F allows this feature to be set (1 to 72), a 0 will disable this function.

LOCKING ERRORS

Fault codes	Cause codes	Description	Reset type	Possible cause
9A	362	HCM (Heat Control Module)	Reset button	Incorrect HCM fitted
9U	233	HCM (Heat Control Module)	Reset button	Problem with the code plug (faulty or not connected)
b7	257	Internal error		Replace control board.
C6	215	Fan problem	Reset button	Fan running too fast
	216	Fan problem	Reset button	Fan running too slow
C7	214	Fan problem	Reset button	Fan not running
	217	No airflow after a defined period of time	Reset button	Fan not running or airflow blocked
D1	240	Return sensor error	Reset button	Sensor wet or damaged (the boiler will block for 300 seconds before this condition).
	241	Return sensor error	Reset button	Sensor disconnected or damaged (the boiler will block for 300 seconds before this condition).
	286	Return temperature too high	Reset button	Boiler overheat
E2	222	Flow sensor short circuit	Reset button	Flow sensor shorted or damaged.
	223	Flow sensor open circuit	Reset button	Flow sensor disconnected or damaged.
E5	218	Flow temperature too high	Reset button	Primary flow sensor overheated
	332	Primary flow sensor has exceeded 110°C	Reset button	Primary flow sensor overheated
E9	219	Safety sensor temperature too high	Reset button	The main heat exchanger has overheated. Maximum temperature 105C°
	220	Safety sensor short circuit	Reset button	Maximum temperature sensor on the main heat exchanger has failed.
	221	Safety sensor open circuit	Reset button	Maximum temperature sensor on the main heat exchanger has not been recognised.
	224	Max temperature thermostat activated	Reset button	Flue gas thermostat overheat
EA	227	No flame detected after ignition	Reset button	Failure of four ignition attempts. The boiler waits 30 seconds before another attempt is made.
	229	Loss of flame signal during operation	Reset button	An established flame has been extinguished. This could be caused by: • moisture in the sump, due to a blocked sump/condensate trap. • a strong wind into the flue.
	234	Gas valve error	Reset button	Gas valve coil disconnected
	261	Ignition timing error	Reset button	Flame not established during the first 4 seconds ignition period.

Table 35 Locking fault and cause code listing

Fault codes	Cause codes	Description	Reset type	Possible cause
F0	237 - 239 242 - 256 258 259 262 263 267 272 279 290	Internal error		Call Worcester, Bosch Group Technical helpline 0330 123 3366
	278	Sensor test failed	Reset button	On power up all safety sensors are checked. Check has failed.
	280	Recycle time error	Reset button	After the burner has stopped, the recycle mode purges gas from the heat exchanger before attempting to burn again. The software has 3.1 seconds to intervene before the boiler goes into this fault condition.
	338	Too many short burner starts without confirmation	Reset button	There is an error where the pump is not detecting water.
F7	228	Flame error	Reset button	False flame. Flame detected before burner start.
	328	Internal error		Replace control board
FA	306	False flame error	Reset button	Flame detected after burner stop
FD	231	Mains power error	Reset button	Electrical power interruption.
FA	364	Gas valve EV2 leak test failed	Reset button	Gas valve leak.
Fb	365	Gas valve EV1 leak test failed	Reset button	Gas valve leak.

Table 35 Locking fault and cause code listing

BLOCKING ERRORS

Fault code	Cause code	Description	Possible cause
A1	281	Pump stuck or running in air	Little or no water in the system.
C1	264	Airflow stopped during operation	Fan has stopped.
C4	273	Airflow present during last 24 hours	Fan has been running continuously during the past 24 hours.
D1	240	Return sensor short circuit	Wet sensor. Blocking for 300 seconds before going to Locking error (→ table 35).
	241	Return sensor disconnected	Blocking for 300 seconds before going to Locking error (→ table 35).
D4	271	Temperature difference between flow and safety sensors exceeds limit	The temperature of the primary flow and the safety sensor on the WB7 should be within 15°C of each other.
E9	224	MAX thermostat activated	Flue gas thermostat overheat.
	276	Flow temperature exceeds 95°C	Primary overheat - boiler waits for temperature to reduce; if not it becomes a Locking error.
	277	Safety temperature exceeds 95°C	Main heat exchanger safety sensor overheat - boiler will wait for the temperature to reduce; if not it becomes a Locking error 219.
	285	Return temperature exceeds 95°C	The boiler will stop the burn and wait to see if it cools down. If after 2 seconds there is an increase in temperature the boiler will go to Locking error 286.
EA	227	No ionisation detected after ignition	No flame is detected. The boiler will block during 4 attempts before going to Locking fault.
EF	349	Central heating, boil detect. Large delta T despite minimum burner.	The boiler is operating at minimum burner load and there is a greater than 18°C Flow & Return temperature difference.
No code	212	Safety or flow temperature rises too fast	Air lock or reduced water content.
	213	Temperature difference between supply and return exceeding limit	Air lock or reduced water content.
	260	No temperature rise after burner starts	Sensor disconnected or no water content.
	380	Inlet DHW temperature higher than the DHW outlet temperature.	The output is blocked until the inlet temperature drops below the output temperature.

Table 36 Blocking codes

NOTES

NOTES

GAS BOILER SYSTEM COMMISSIONING CHECKLIST

This Commissioning Checklist is to be completed in full by the competent person who commissioned the boiler as a means of demonstrating compliance with the appropriate Building Regulations and then handed to the customer to keep for future reference.

Failure to install and commission according to the manufacturer's instructions and complete this Benchmark Commissioning Checklist will invalidate the warranty. This does not affect the customer's statutory rights.

Customer name:	Telephone number:
Address:	
Boiler make and model:	
Boiler serial number:	
Commissioned by (PRINT NAME):	Gas Safe register number:
Company name:	Telephone number:
Company address:	
Commissioning date:	
To be completed by the customer on receipt of a Building Regulations Compliance Certificate*	
Building Regulations Notification Number (if applicable):	

CONTROLS (tick the appropriate boxes)			
Time and temperature control to heating	Room thermostat and programmer/timer	<input type="checkbox"/>	Programmable room thermostat
	Load/weather compensation	<input type="checkbox"/>	Optimum start control
Time and temperature control to hot water	Cylinder thermostat and programmer/timer	<input type="checkbox"/>	Combination Boiler
Heating zone valves	Fitted	<input type="checkbox"/>	Not required
Hot water zone valves	Fitted	<input type="checkbox"/>	Not required
Thermostatic radiator valves	Fitted	<input type="checkbox"/>	Not required
Automatic bypass to system	Fitted	<input type="checkbox"/>	Not required
Boiler interlock		<input type="checkbox"/>	Provided

ALL SYSTEMS			
The system has been flushed and cleaned in accordance with BS7593 and boiler manufacturer's instructions	Yes	<input type="checkbox"/>	
What system cleaner was used?			
What inhibitor was used?	Quantity		litres
Has a primary water system filter been installed?	Yes	<input type="checkbox"/>	No <input type="checkbox"/>

CENTRAL HEATING MODE measure and record:			
Gas rate	m ³ /hr	OR	ft ³ /hr
Burner operating pressure (if applicable)	mbar	OR Gas inlet pressure	mbar
Central heating flow temperature	°C		
Central heating return temperature	°C		

COMBINATION BOILERS ONLY			
Is the installation in a hard water area (above 200ppm)?	Yes	<input type="checkbox"/>	No <input type="checkbox"/>
If yes, and if required by the manufacturer, has a water scale reducer been fitted?	Yes	<input type="checkbox"/>	No <input type="checkbox"/>
What type of scale reducer has been fitted?			

DOMESTIC HOT WATER MODE Measure and Record:			
Gas rate	m ³ /hr	OR	ft ³ /hr
Burner operating pressure (at maximum rate)	mbar	OR Gas inlet pressure at maximum rate	mbar
Cold water inlet temperature	°C		
Hot water has been checked at all outlets	Yes	<input type="checkbox"/>	Temperature °C <input type="checkbox"/>
Water flow rate	l/min		

CONDENSING BOILERS ONLY			
The condensate drain has been installed in accordance with the manufacturer's instructions and/or BS5546/BS6798	Yes	<input type="checkbox"/>	

ALL INSTALLATIONS			
Record the following:	At max. rate:	CO ppm	AND CO/CO ₂ Ratio
	At min. rate: (where possible)	CO ppm	AND CO/CO ₂ Ratio
The heating and hot water system complies with the appropriate Building Regulations	Yes	<input type="checkbox"/>	
The boiler and associated products have been installed and commissioned in accordance with the manufacturer's instructions	Yes	<input type="checkbox"/>	
The operation of the boiler and system controls have been demonstrated to and understood by the customer	Yes	<input type="checkbox"/>	
The manufacturer's literature, including Benchmark Checklist and Service Record, has been explained and left with the customer	Yes	<input type="checkbox"/>	

Commissioning Engineer's Signature
Customer's Signature
(To confirm satisfactory demonstration and receipt of manufacturer's literature)

*All installations in England and Wales must be notified to Local Authority Building Control (LABC) either directly or through a Competent Persons Scheme. A Building Regulations Compliance Certificate will then be issued to the customer.



SERVICE RECORD

It is recommended that your heating system is serviced regularly and that the appropriate Service Interval Record is completed.

Service Provider

Before completing the appropriate Service Record below, please ensure you have carried out the service as described in the manufacturer's instructions. Always use the manufacturer's specified spare part when replacing controls.

SERVICE 01					Date:
Engineer name:					
Company name:					
Telephone No:					
Gas safe register No:					
Record:	At max. rate:	CO	ppm	AND	CO ₂ %
	At min. rate: (Where Possible)	CO	ppm	AND	CO ₂ %
Comments:					
Signature					

SERVICE 02					Date:
Engineer name:					
Company name:					
Telephone No:					
Gas safe register No:					
Record:	At max. rate:	CO	ppm	AND	CO ₂ %
	At min. rate: (Where Possible)	CO	ppm	AND	CO ₂ %
Comments:					
Signature					

SERVICE 03					Date:
Engineer name:					
Company name:					
Telephone No:					
Gas safe register No:					
Record:	At max. rate:	CO	ppm	AND	CO ₂ %
	At min. rate: (Where Possible)	CO	ppm	AND	CO ₂ %
Comments:					
Signature					

SERVICE 04					Date:
Engineer name:					
Company name:					
Telephone No:					
Gas safe register No:					
Record:	At max. rate:	CO	ppm	AND	CO ₂ %
	At min. rate: (Where Possible)	CO	ppm	AND	CO ₂ %
Comments:					
Signature					

SERVICE 05					Date:
Engineer name:					
Company name:					
Telephone No:					
Gas safe register No:					
Record:	At max. rate:	CO	ppm	AND	CO ₂ %
	At min. rate: (Where Possible)	CO	ppm	AND	CO ₂ %
Comments:					
Signature					

SERVICE 06					Date:
Engineer name:					
Company name:					
Telephone No:					
Gas safe register No:					
Record:	At max. rate:	CO	ppm	AND	CO ₂ %
	At min. rate: (Where Possible)	CO	ppm	AND	CO ₂ %
Comments:					
Signature					

SERVICE 07					Date:
Engineer name:					
Company name:					
Telephone No:					
Gas safe register No:					
Record:	At max. rate:	CO	ppm	AND	CO ₂ %
	At min. rate: (Where Possible)	CO	ppm	AND	CO ₂ %
Comments:					
Signature					

SERVICE 08					Date:
Engineer name:					
Company name:					
Telephone No:					
Gas safe register No:					
Record:	At max. rate:	CO	ppm	AND	CO ₂ %
	At min. rate: (Where Possible)	CO	ppm	AND	CO ₂ %
Comments:					
Signature					

SERVICE 09					Date:
Engineer name:					
Company name:					
Telephone No:					
Gas safe register No:					
Record:	At max. rate:	CO	ppm	AND	CO ₂ %
	At min. rate: (Where Possible)	CO	ppm	AND	CO ₂ %
Comments:					
Signature					

SERVICE 10					Date:
Engineer name:					
Company name:					
Telephone No:					
Gas safe register No:					
Record:	At max. rate:	CO	ppm	AND	CO ₂ %
	At min. rate: (Where Possible)	CO	ppm	AND	CO ₂ %
Comments:					
Signature					

*All installations in England and Wales must be notified to Local Authority Building Control (LABC) either directly or through a Competent Persons Scheme. A Building Regulations Compliance Certificate will then be issued to the customer.



Worcester, Bosch Group
Cotswold Way, Warndon, Worcester WR4 9SW.
Tel. 0330 123 9559

Worcester, Bosch Group is a brand name of Bosch Thermotechnology Ltd.
worcester-bosch.co.uk

6 720 813 280 (2015/07)

WORCESTER, BOSCH GROUP:

TECHNICAL SUPPORT: 0330 123 3366
APPOINTMENTS: 0330 123 9339
SPARES: 0330 123 9779
LITERATURE: 0330 123 9119
TRAINING: 0330 123 0166
SALES: 0330 123 9669

The logo for Worcester Bosch Group features a stylized, wavy graphic element on the left, composed of three overlapping, curved lines in shades of grey and black. To the right of this graphic, the word "WORCESTER" is written in a large, bold, black, sans-serif font. Below "WORCESTER", the words "Bosch Group" are written in a smaller, bold, black, sans-serif font.

WORCESTER
Bosch Group