



20/80 RSS Flowmatic

Installation and Servicing Instructions

G.C. No. 41 094 05
British Gas Tested and Certified

HAND THESE
INSTRUCTIONS
TO THE USER.

This Appliance is for use
with Natural Gas only.

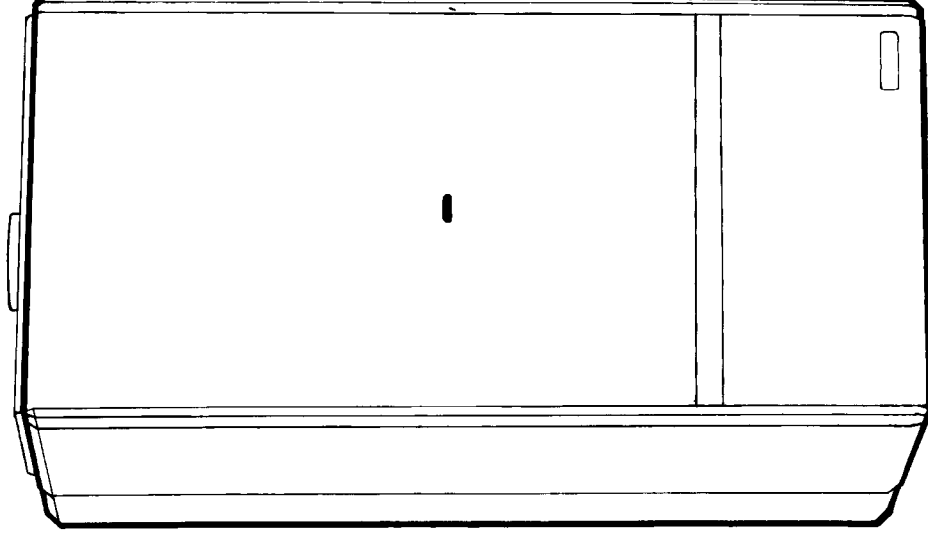

SECTION 1 INTRODUCTION

The Vokéra 20/80 RSS Flowmatic is a central heating appliance. By design it incorporates a circulating pump, expansion vessel, safety valve, temperature gauge, pressure gauge and automatic by-pass. It is produced as a room sealed category 1N appliance suitable for wall mounting applications only. It is provided with a fan powered flue outlet with an annular co-axial combustion air intake which can be rotated through 360 degrees.

The appliance is designed for use with a sealed heating system only and is not intended for use on an open vented system.

A range-rating facility is incorporated in the boiler for the central heating system in conjunction with the high/low burner control.

The provision of stored domestic hot water is possible by the addition of an indirect cylinder with 'Y' or 'S' plan controls.

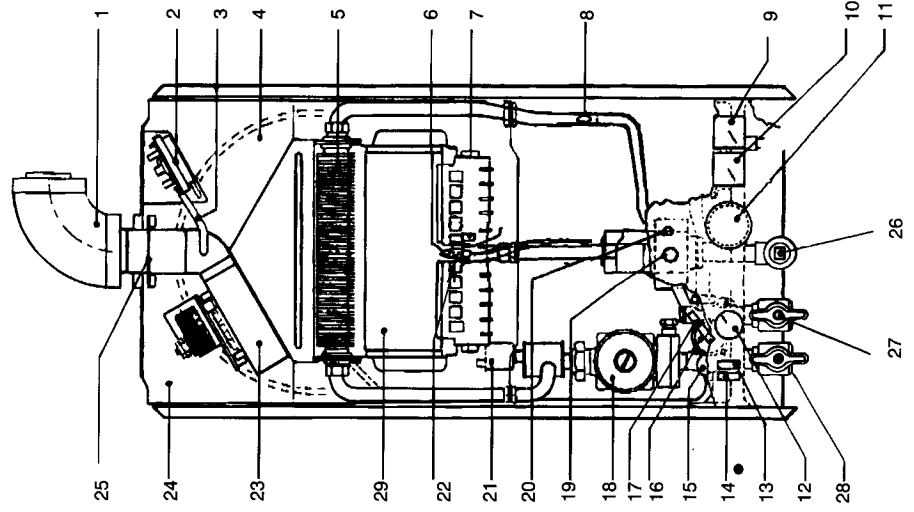

Fig.1 General Layout

- 1 Air Intake
- 2 Pressure Differential Switch
- 3 Silicone Pressure Tube
- 4 Expansion Vessel
- 5 Main Heat Exchanger
- 6 Pilot Assembly
- 7 Main Burner
- 8 High Limit Thermostat
- 9 Pressure Gauge
- 10 Temperature Gauge
- 11 Time Clock (optional extra)
- 12 Heating Thermostat
- 13 Mode Selector Switch
- 14 Boiler On/Off Switch
- 15 Safety Valve
- 16 Heating Manifold
- 17 Boiler Flow Switch
- 18 Pump
- 19 Gas Valve Knob
- 20 Piezo Igniter Button
- 21 Automatic Air Vent
- 22 Thermocouple
- 23 Fan
- 24 Roomsealed Chamber
- 25 Flue Outlet
- 26 Gas Service Tap
- 27 Central Heating Flow Valve
- 28 Central Heating Return Valve
- 29 Combustion Chamber

SECTION 3 TECHNICAL DATA

- 3.1 Units**
Dimensions and values are given in the preferred SI Units with Imperial units in brackets where applicable.
- 3.2 Dimensions and Contents**
Height: 1065mm (42in) overall (890 casing)
Width: 450mm (17.7in)
Depth: 360mm (14.2in)
Weight (empty): 48kg (105lb) (full 51kg (112lb))
Water content: 2.0 litres (.5 gals) for further dimensions see figs 13 - 16
- 3.3 Connection sizes**
Heating flow and return: Nut and olive for 22mm o.d.
Gas Service: Rc 1/2 (1/2in BSP int)
Safety valve outlet: Rc 1/2 (1/2in BSP int)
Flue outlet: nominal dia 100mm specially supplied with boiler.
- 3.4 Installation Requirements**
- 3.4.1 Clearances**
Minimum - above 50mm (2in) (above flue)
Minimum - below 300mm (12in) from casing
Minimum - in front 600mm (24in) from casing
Minimum - At sides 75mm (3in) from casing
Maximum heating system contents approx. 96 litres (21 gals)
- 3.4.2**
Acceptance capacity of expansion vessel 10 litres (2.2 gals).
- 3.4.3 Air supply/Ventilation:** To requirements of BS 5440 Part 2 1989
- 3.4.4**
Means of filling sealed system: To accord with BS and/or local Water Authority requirements.

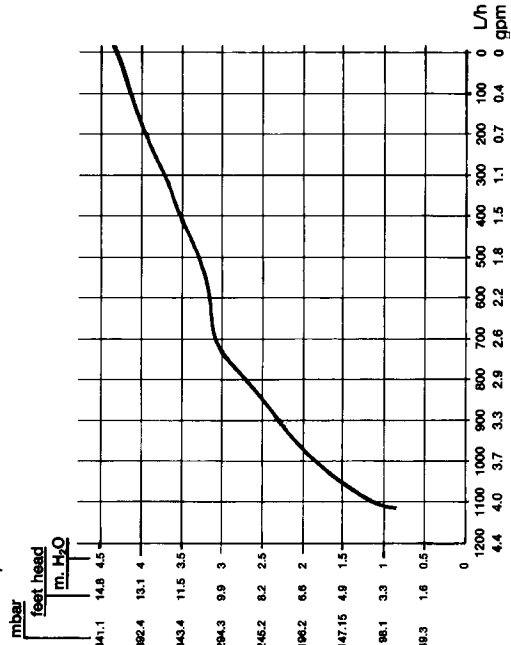
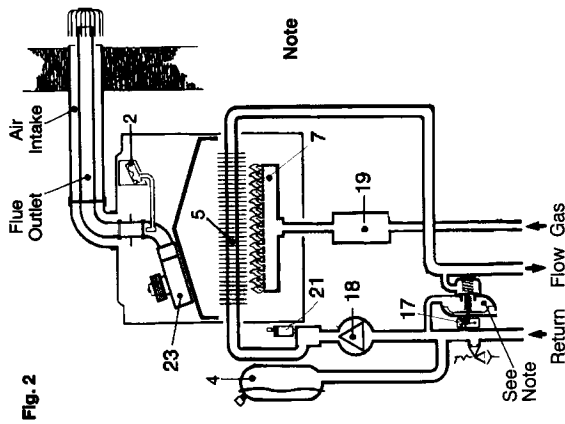

Fig. 3 Available pump head



Note

Differential pressure unit. Senses water flow rate through pump & main heat exchanger and operates flow switch(17)

See Note

SECTION 2 DESIGN PRINCIPLES AND OPERATING SEQUENCE

- 2.1** Fig. 1 illustrates the general layout of components. Fig. 2 illustrates the operating principles described below
- 2.2 Ignition and Rest Mode**
- 2.2.1** With the appliance on/off switch (14) in the 'off' (O) position, the pilot is ignited by depressing the gas valve knob (19) and pressing the Piezo button (20).
- 2.2.2** As soon as a pilot flame is established and the gas valve knob released, the on/off switch (14) must be switched 'on' (I). This allows the flue fan to run at slow speed to scavenge the combustion chamber and provide air for the pilot burner.
- 2.2.3** In this mode (Rest), the appliance remains 'ticking over' until the switch is turned to either Timed or Constant (see 2.3.4).
- 2.3 Central Heating Mode**
- 2.3.1** When the various switches and controls impose a demand for heat, the fan is switched to full speed. The pump is switched on and flow of water operates a flow switch. This in turn energises the gas valve operator permitting gas flow through the main burner to be ignited by the permanent pilot flame.
- 2.3.2** As water temperature increases this is sensed by the thermostat which eventually operates at its first stage to switch the burner to low flame.
- 2.3.3** Depending on the load, either the water temperature will continue to rise when the second stage of the thermostat (12) will operate to switch the burner off, or the water temperature will fall and re-establish high flame.
- 2.3.4 Function of Timed/Rest/Constant Switch**
REST: The appliance remains 'ticking' over until the the switch is turned to either Timed or Constant.
TIMED: The appliance will operate only when it is commanded to do so by the internal timeclock (if fitted).
CONSTANT: The appliance will run continuously overriding the commands of the internal timeclock. Or if an external timeclock and/or roomstat is fitted the appliance will receive commands from them.
- 2.4 Safety Devices**
- 2.4.1** In both central heating and hot water modes safe operating is ensured by
- (a) Differential pressure unit in primary circuit which prevent burner operation if water flow rate is too low.
 - (b) A high limit thermostat, which interrupts the flame supervision circuit.
 - (c) At the same time the fan will still operate.
- 2.4.2** A safety valve is provided to relieve excess pressure from the primary circuit.

Working Pressures Heating System

Maximum 1.5bar/15m.wg/50ft wg
 Minimum 0.5bar/5m.wg/16ft wg
 Safety valve setting 3bar/30m/102ft

Flow Rates

Min. central heating flow rate through appliance 350 litres/h (1.28 gal/min).

Gas Rates Min. Gas Rate m³/h 1.13 ft³/h 39.9
 Max. Gas Rate m³/h 2.68 ft³/h 94.7

3.7 Burner Details

Main Burner Polidoro NP 12
 Main Burner Injectors 12 x 1.35
 Burner Pressure Max. 9.5 mbar
 Burner Pressure Min. 1.2 mbar

Gas Control Valve: Basic Honeywell VR4600 1128 2 220/240V This unit is modified.

The modification comprises a coil carried by the main burner regulation screw. For low flame a voltage of approx. 12.5vdc is applied to the coil to hold the valve spindle against the mechanical stop. For central heating max. rate the valve is restricted in its max. opening by application of a site adjustable voltage.

SECTION 4 GENERAL REQUIREMENTS

4.0 General Requirements

This appliance must be installed by a competent person in accordance with the Gas Safety (Installation & Use) Regulations 1984.

4.1 Related Documents

The installation of this boiler must be in accordance with the relevant requirements of the Gas Safety (Installation & Use) Regulations 1984, the Local Building Regulations, the current I.E.E. Wiring Regulations, the by-laws of the local water undertaking, and in Scotland, in accordance with the Building Standards (Scotland) Regulation.

It should be in accordance also with any relevant requirements of the local gas region and local authority and the relevant recommendations of the following British Standard Codes of Practice:

BS 6891	1988	Low pressure installation pipes
BS 6798	1987	Boilers of rated input not exceeding 60kW.
BS 5449	Part 1	Forced circulation hot water systems
BS 5440	Part 1	Flues
BS 5440	Part 2	Air supply.

The location chosen for the boiler must permit the provision of a satisfactory flue and termination. The location must also permit an adequate air supply for combustion purposes and an adequate space for servicing and air circulation around the boiler.

Where the installation of the boiler will be in an unusual location special procedures may be necessary and BS 6798:1987 gives detailed guidance on this aspect.

A compartment used to enclose the boiler must be designed and constructed specifically for this purpose. An existing cupboard or compartment may be used provided that it is modified for this purpose. Details of essential features of cupboard/compartment design including airing cupboard installations are given in BS 6798:1987 and BS 5440 pt 2 1989. This appliance is not suitable for external installation.

4.3 Gas Supply

A gas meter is connected to the service pipe by the local gas region or a local gas region contractor.

An existing meter should be checked, preferably by the gas region to ensure that the meter is adequate to deal with the rate of gas supply required for all appliances it serves.

Installation pipes should be fitted in accordance with BS 6891:1988.

Pipework from the meter to the boiler must be of adequate size. Pipes of a smaller size than the boiler inlet connection should not be used.

The complete installation must be tested for soundness as described in the above code.

N.B. If the gas supply for the boiler serves other appliances ensure that an adequate supply is available both to the boiler and the other appliance when they are in use at the same time.

4.4 Flue System

The terminal should be located where dispersal of combustion products is not impeded and with due regard for the damage or discolouration that might occur to building products in the vicinity (see fig 4).

In cold and/or humid weather water vapour may condense on leaving the flue terminal. The effect of such 'steaming' must be considered.

The terminal must not be closer than 50mm (2in) to any combustible material. For protection of combustibles, refer to BS 5440:1 where the terminal is less than 2m (6.6ft) above a pavement or platform to which people have

access (including any balcony or flat roof) the terminal must be protected by a guard of durable material.

A suitable guard is available from G.R. Claudio (Vokera) Ltd. Part No 018, G.C. No. 301 106.

This guard must be fitted centrally over the terminal.

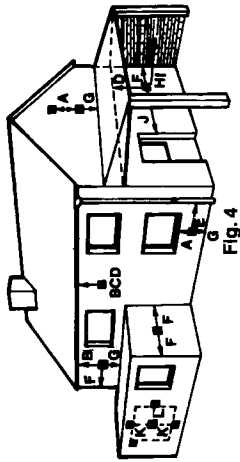

Terminal position for fan assisted boiler (minimum distance)

A	Directly below an open window or other opening (e.g. air brick)	300
B	Below gutters, soil pipes or drain pipes	75
C	Below eaves	200
D	Below balconies or car port roof	200
E	From vertical drain pipes and soil pipes	75
F	From internal or external corners	300
G	From a surface facing a terminal	300
H	From a terminal facing a terminal	600
I	From an opening in the car port (e.g. door window) into dwelling	1200
J	Vertically from a terminal on the same wall	1500
K	Horizontally from a terminal on the same wall	300

4.5 Air Supply

Recommendations for air supply are detailed in BS 5440:2:1989. The following notes are intended for general guidance.

The room sealed fan flued boiler does not require a permanent air vent for combustion air supply.

Where installed in a cupboard or compartment ventilation is required for cooling.

The table below gives the recommended minimum effective areas of such air vents

1. Both vents must either communicate with the same room or space or be on the same outside wall.

2. Where vents communicate with an adjacent internal space, it is suggested that the space is adequately ventilated.

POSITION OF AIR VENTS	AIR VENT AREAS	
	AIR FROM ROOM OR SPACE	AIR DIRECT FROM OUTSIDE
high level	257cm ² (99.0in ²)	128cm ² (19.5in ²)
low level	257cm ² (99.0in ²)	128cm ² (19.5in ²)

N.B.

4.6

Water Circulation

Detailed recommendations are given in BS 6798:1987 and BS 5449:1:1977 for smallbore and microbore central heating systems).

The following notes are given for general guidance.

4.6.1

Pipework

Copper tubing to BS 2871:1:1971 is recommended for water pipe. Jointing should be either by capillary soldered or with compression fittings.

Where possible, pipes should have a gradient to ensure air is carried naturally to air release points and water flows naturally to drain taps.

It should be ensured as far as possible that the appliance heat exchanger is not a natural collecting point for air.

4.6.2

Except where providing useful heat, pipes should be insulated to prevent heat loss and to avoid freezing. Particular attention should be paid to pipes passing through ventilated spaces in roofs and under floors.

By-Pass

An automatic by-pass is incorporated in the boiler and systems should be designed to ensure that with only one radiator turned on a flow rate of at least 350 litres/hour (1.28 gals/min) is achieved through the boiler.

System Design

Figs 5 & 6 illustrate typical layouts.

Draining Taps

These must be located in accessible positions to permit the draining of the whole system. The taps must be at least 15mm nominal size and manufactured in accordance with BS 2879:1980.

4.6.3

An automatic by-pass is incorporated in the boiler and systems should be designed to ensure that with only one radiator turned on a flow rate of at least 350 litres/hour (1.28 gals/min) is achieved through the boiler.

System Design

Figs 5 & 6 illustrate typical layouts.

Draining Taps

These must be located in accessible positions to permit the draining of the whole system. The taps must be at least 15mm nominal size and manufactured in accordance with BS 2879:1980.

4.6.4

An automatic by-pass is incorporated in the boiler and systems should be designed to ensure that with only one radiator turned on a flow rate of at least 350 litres/hour (1.28 gals/min) is achieved through the boiler.

System Design

Figs 5 & 6 illustrate typical layouts.

Draining Taps

These must be located in accessible positions to permit the draining of the whole system. The taps must be at least 15mm nominal size and manufactured in accordance with BS 2879:1980.

4.6.5

An automatic by-pass is incorporated in the boiler and systems should be designed to ensure that with only one radiator turned on a flow rate of at least 350 litres/hour (1.28 gals/min) is achieved through the boiler.

System Design

Figs 5 & 6 illustrate typical layouts.

Draining Taps

These must be located in accessible positions to permit the draining of the whole system. The taps must be at least 15mm nominal size and manufactured in accordance with BS 2879:1980.

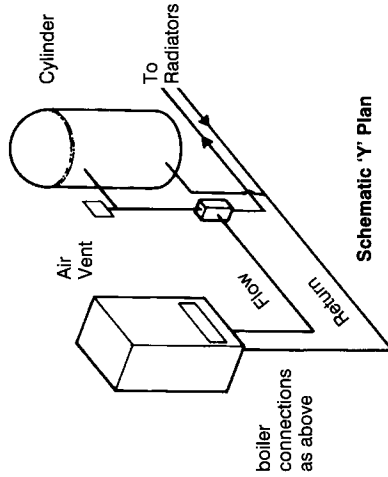

boiler connections as above

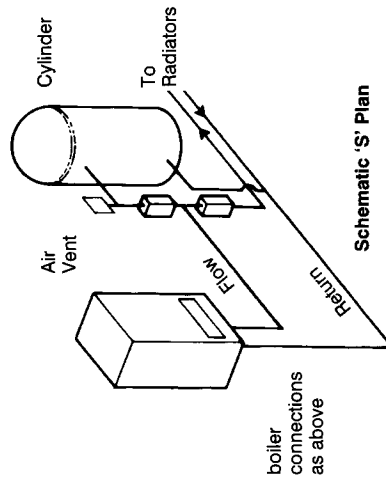

boiler connections as above

Fig. 5

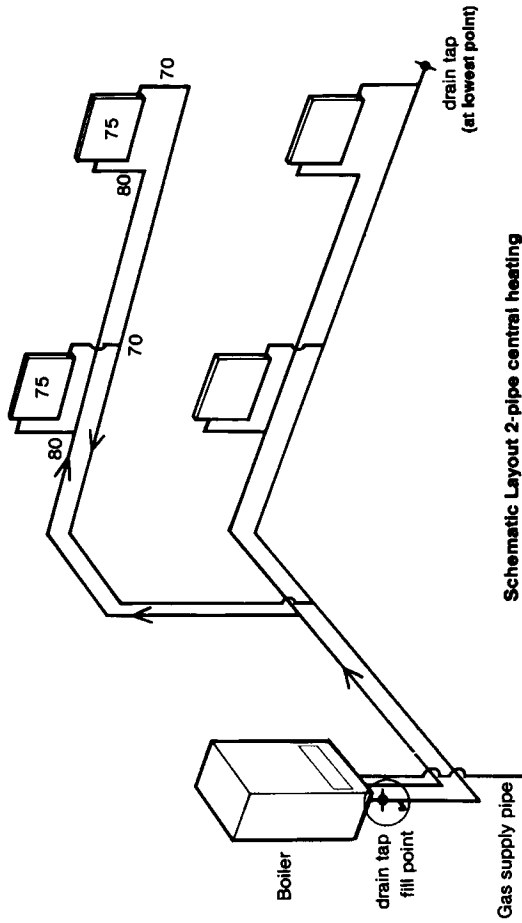

Schematic Layout 2-pipe central heating

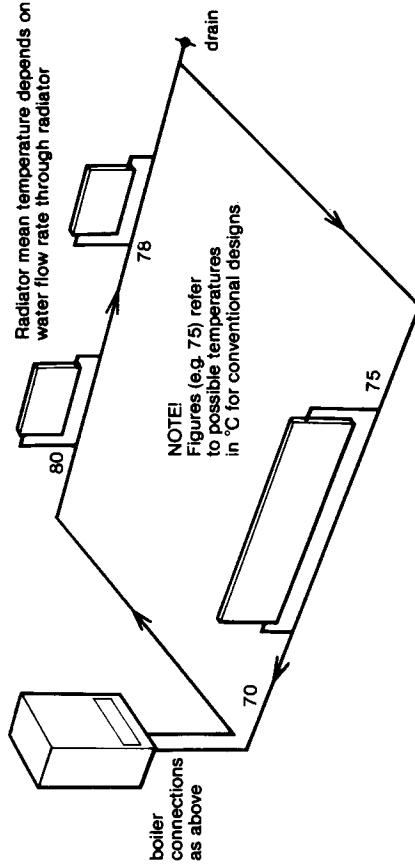

Fig. 6 Schematic single pipe central heating

Salient features of each system

2 Pipe

- Radiators connected in parallel
- Water flow to each directly affected pump
- Shutting off radiators affects total flow in system
- Radiators have approx. same mean temperature
- Low flow rate affects all radiators equally

1 Pipe

- Each radiator is on individual circuit off main pipe
- Water flow not directly affected by pump. Flow in each radiator depends on thermostat + pressure differential between connection to main circuit
- Shutting off individual radiators hardly affect total flow in system.
- Radiator mean temperature progressively drops around systems.
- Low flow rate seriously affects last radiators on circuit.

N.B. Vokera Ltd recommend a 2-pipe system. Single pipe systems are more liable to be troublesome unless carefully designed and installed.

4.6.6 Air Release Points

These must be fitted at all high points where air will naturally collect, and must be sited to facilitate complete filling of the system.

4.6.7

The appliance has an integral sealed expansion vessel to accommodate the increase of water volume when the system is heated. It can accept up to 10 litres (2.2gals) of expansion water. If the appliance is connected to a system with an unusually high water content. Calculate the total expansion and add additional sealed expansion capacity as appropriate.

In general, modern systems will present no problem.

4.6.8 Filling Point

A method for initially filling the system and replacing water lost during servicing must be provided, and it must comply with local water authority regulations.

A method is shown in fig 7 using the Vokèra filling loop which is acceptable in most areas. In the event that this method is not suitable in a particular area, contact the local authority for preferred methods.

N.B. The installer should ensure that no leaks exist as frequent filling of the system could cause premature scaling of the main heat exchanger.

Electrical Supply

The appliance is supplied for operation on 240/250V ~ 50Hz electricity supply. It should be protected with a 3-amp fuse.

THIS APPLIANCE MUST BE EARTHED.

The method of connection to the mains electricity must allow complete isolation from the supply.

The preferred method is by using a fused double pole switch with a contact separation of at least 3mm.

The switch must supply ONLY the appliance and immediate electrical control circuits (e.g. programmer/room thermostat). Alternatively, use an unswitched shrouded socket outlet with a fused 3-pin plug both complying with BS 1363.

5.1

Delivery (fig 8)

The appliance is delivered in a heavy duty cardboard carton.

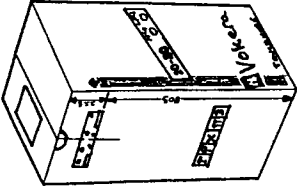

Fig. 8

5.2

Unpacking (Fig 9)

Pull both sides of the carton open. Do not use a knife. Unfold the rest of the carton from around the boiler.

Lay the boiler with the black frame on the floor. Remove the two polystyrene blocks at the top of the boiler from either side of the red expansion vessel.

Remove the polystyrene block at the base of the boiler containing the boiler fixing kit and hanging bracket.

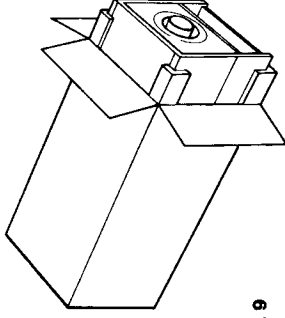
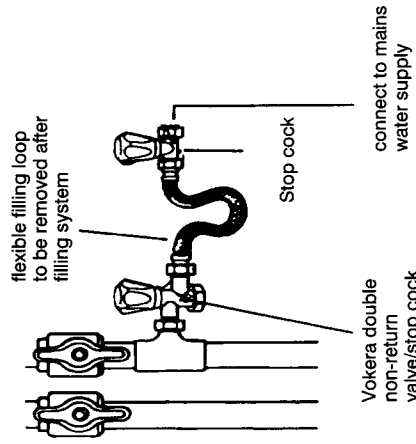

Fig. 9

The fixing kit contains

- 1 - Wall bracket
- 1 - Fittings pack containing:
 - central heating valves (2)
 - Gas service tap (1)
- Various washers
- 1 - Installation & Service Manual.
- Fixing template

Fig.7



5.3

The Flue Kit is supplied in a separate carton.

Preparing for Mounting

Remove 4 screws securing the lower part of the casing to the case frame. (Fig 10)

Slightly lift the casing and slide it gently towards the top of the appliance to disengage the case from the top suspension hooks. (Fig 11)

Ensure the casing and screws are put to one side in a safe place.

Loosely fit (hand tight) the valves and fittings using the washers supplied (Fig 12)

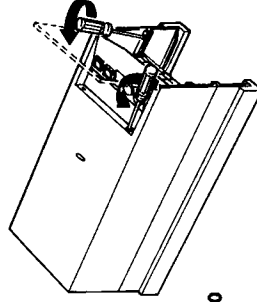

Fig. 10

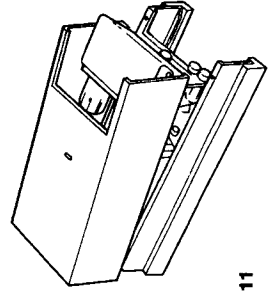

Fig. 11

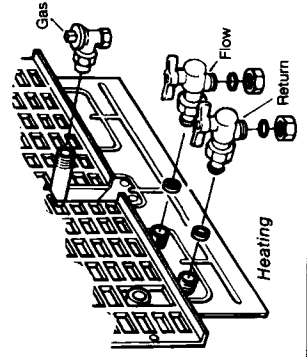

Fig. 12

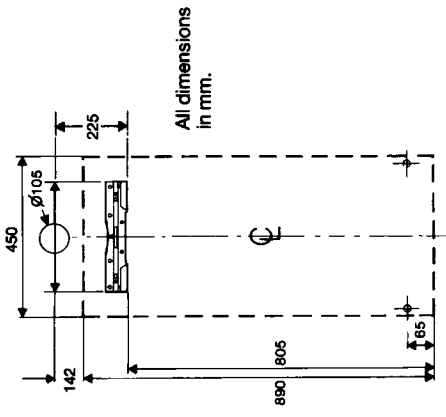

Fig. 13

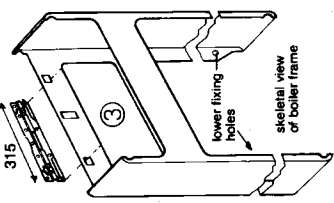

Fig. 14

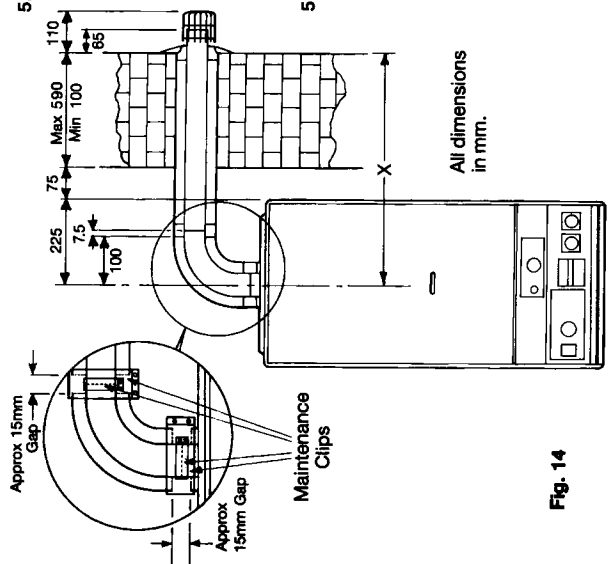

Fig. 15

5.4 Mounting the Appliance (Fig 13)

Place the template on a smooth, vertical incombustible surface and use it to locate the upper bracket, bottom fixing and flue pipe holes.

Alternatively, position bracket and holes to dimensions in fig 13.

Drill and plug the wall for 2 - 2" No 10 screws for upper bracket and screw the bracket firmly into position using rust proof countersunk screws.

Hang the boiler on the bracket and adjust to final position. Mark the lower fixing holes.

Remove boiler and drill and plug wall for 2 x 1 1/2" No 10 screws.

Drill a 105mm hole through the wall to allow passage of the flue pipe.

Refer to fig. 13 and figs. 14-18 for relevant dimensions for locating the hole. Where it is remote from the boiler take special care to ensure hole is at the correct level so that the finished flue is horizontal.

Fitting the Flue

Refer to figures 14 - 18

The flue outlet elbow may be rotated 360 degrees on its vertical axis. The flue may be extended from this in the horizontal plane.

The standard flue pipe supplied may be used for extension up to 890mm - from outside of wall to centre of the flue elbow. Extension kits (Part No. 026, G.C. No. 370 346) are available to order for flue extensions of up to 4.5 metres total length.

Hang the boiler on the bracket. Adjust the boiler sideways to its correct position.

Measure carefully from the actual face of the outside wall to the centre of the flue bend. (Dimension X on Figs. 14 & 15).

Locate the small maintenance clip on to the flue elbow fig. 14 and assemble onto the flue outlet on the top of the boiler. Twist the flue bend to the outlet direction required, and tighten the maintenance clip to secure the flue bend in place. Carefully level across to check that the hole through the wall is at the same level as the flue bend.

The flue kit supplied is suitable for an exact extension of 890mm. Extension tubes will increase X to the following:

- 1 extension = 1740mm
 - 2 extensions = 2590mm
 - 3 extensions = 3440mm
 - 4 extensions = 4290mm
- Cut 5th extension for a Maximum length of 4.5 metres.

5.5.5

Where X is less than 890mm, the supplied flue must be shortened as follows:-
Separate the two tubes by removing screw G (fig. 17).

Subtract the measured length from 890mm. The difference is the precise length to be removed from both tubes (890 - X = length to be cut off from the plain ends.)

Example

X is measured as 630mm Amount to be cut off both tubes is 890 - 630 = 260.

Where X is more than 890mm an extension kit (or kits) is needed. The standard uncut lengths with extension(s) is shown in section 5.5.4

Always cut the extension tubes, not the standard tube.

1. Measure X

2a. If using 1 extension piece, cut (1770 - X)mm from the inner flue tube but (1750 - X)mm from the outer air tube.

2b. If using 2 extension pieces, cut (2600 - X)mm from the inner flue tube but (2560 - X)mm from the outer air tube.

Shorten inner and outer tubes of last extension piece.

EXAMPLE

X = 1295

Cut 1770 - 1295 = 465mm from airtube

Cut 1750 - 1295 = 445mm from flue tube

CUT CLEAN AND SQUARE WITH FINE TOOTH SAW AND REMOVE BURRS.

Loosen the small maintenance clip and lift the flue bend off the boiler flue outlet.

Ensure inner and outer terminal tubes are firmly fitted together with screw G (fig. 17). Push the terminal tubes through the wall until the face of the outer tube protrudes 18mm from the face of the wall (fig. 17). The terminal grill (D) will then protrude 110mm from the wall face.

If extension pieces are used assemble these using the maintenance clips provided. Always fully butt the joints before securing the clips.

Make sure the entire length of the flue is truly horizontal and adequately supported. Use at least one bracket for each extension. (Conventional adjustable strap supports, Part No. 03, G.C. No. 307105, suffice, Vokëra stockist can supply if necessary)

Assemble the second small maintenance clip on the end of the inner flue tube.

Refit the flue elbow onto the boiler. Align the flue elbow with the flue pipe and tighten the maintenance clip between the flue elbow and the boiler. Ensure pipe sections butt together.

5.5.6

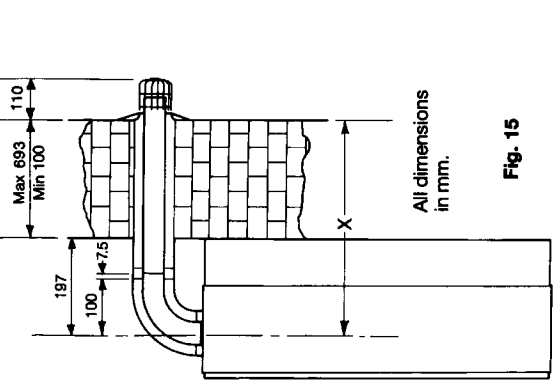

Fig. 15

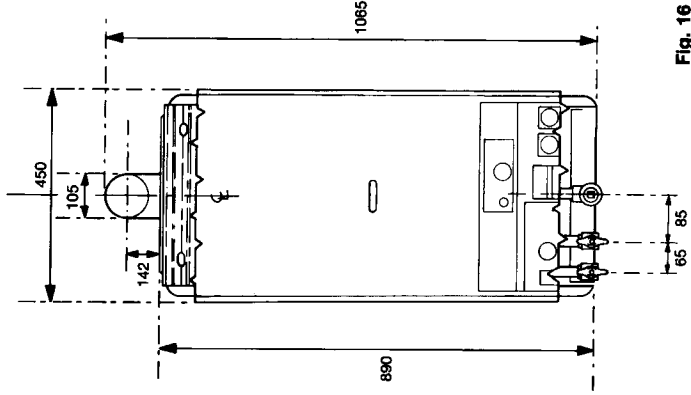

Fig. 16

All dimensions in mm.

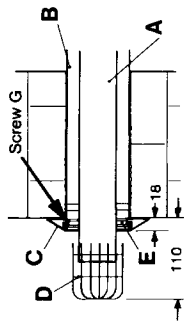

Fig. 17

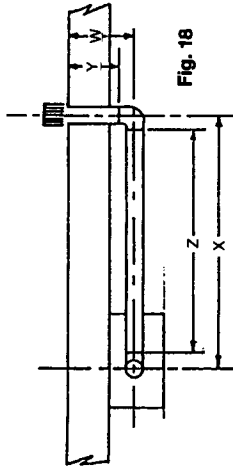

Fig. 18

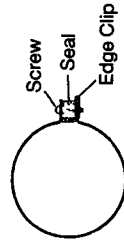

Fig. 18a

- 5.5.13** Draw the flue pipe towards the boiler and tighten the second clip over the joint between the inner flue pipe and the flue elbow.
- 5.5.14** There must now be a gap of approximately 15mm from the elbow to the end of the outer tube.
- 5.5.15** Check also that the outer end of the flue projects as indicated in fig. 17.
- 5.5.16** Referring to fig. 14 fit the large maintenance clips into position and secure the clip screws.
- 5.5.17** Check adjust and tighten all supports.
- 5.5.18** Seal the peripheral gap around the outer tube with cement or mastic and slip the cosmetic flexible plastic collar (fig. 17) item (C) into groove on the pipe. This operation can only be carried out with external access. Seal the internal wall face around the air duct.
N.B. Absence of the collar will not affect operation of the appliance but the outer wall must be weather proofed around the air duct.
- 5.5.19** When the flue and appliance are finally positioned screw the lower frame to the wall (fig. 13)
- 5.5.20** **Installing optional 90 degree flue bend**
Part No. 02, G.C. No. 301104
- 5.5.21** Assemble the large and small maintenance clips as shown in fig 18A
- 5.5.22** Carry out steps 5.5.2-5.5.3

- 5.5.23** Ensure when siting the flue hole position that the combined distances (Y&Z on fig 18) between the flue elbow on the boiler to the extra bend and from the face of the outside wall to the extra bend do not total more than 3.75 metres.
- 5.5.24** Measure carefully the distance between the centre of the flue bend on the boiler to the centre of the hole through the wall (dimension X fig. 18).
NOTE: Extension kits part no 026 will be required if the distance measured is greater than 780mm
- 5.5.25** Subtract 230mm from the measured dimension, separate the two tubes and cut the outer tube to this dimension.
- 5.5.26** Cut the inner tube 15mm longer than the outer tube.
- 5.5.27** Referring to fig. 14 assemble a small maintenance clip on the outlet of the boiler flue bend. Push the inner flue tube into clip and tighten clip screws.
- 5.5.28** Slide the outer flue tube into place leaving approx. 15mm between the bend and the flue tube.
- 5.5.29** Referring to fig. 14 fit the large maintenance clip into position and tighten clip screws.
- 5.5.30** Connect the flue tube to the extra bend using the same method ensuring that the bend outlet is in line with the hole through the wall
- 5.5.31** Ensure that the flue pipe runs parallel to the wall then carefully measure the distance from the outside face of the wall to the centre of the extra bend (dimension W fig. 18).
- 5.5.32** Subtract 97mm from the dimension and cut the outer tube to this length.
NOTE: The two tubes must be separated by removing screw G fig 17 before cutting.
- 5.5.33** Ensure that any shortening of the tube is done from the plain end.
- 5.5.34** Reassemble the inner and outer flue tubes and refix screw G.
- 5.5.35** Mark the inner tube 7mm longer than the outer and cut off the inner tube at this point.
- 5.5.36** Remove the large maintenance clip, loosen the small clip and remove the bend.
- 5.5.37** Push the flue tubes through the wall, loosely refit the extra flue bend.
- 5.5.38** Assemble a small maintenance clip onto the inner flue tube, draw the flue tube towards the flue bend until the inner tubes butt. Tighten the screws on the small clip.
- 5.5.39** Referring to fig. 14 fit the large maintenance clip into position and secure clip screws.
- 5.5.40** Check and adjust if necessary so that the outer flue tube protrudes 18mm from the outside face of the wall.

5.5.41 Tighten all maintenance clips, make sure that the entire flue is horizontal and adequately supported. Use at least one bracket (Part No. 03, G.C. No. 301 105) for each extension.

Connecting the Gas and Water

- 5.6** Figs. 12 and 16 show the locations of the fittings.
- 5.6.1** Do not over tighten nuts and use another spanner to apply counter force to avoid damaging the appliance
- 5.6.2** **Gas Supply**
Connecting the gas supply.
Connect a 15mm gas pipe to the gas service tap and tighten the union nut securing the tap to the appliance.
- 5.6.4** **Central Heating** Connect the central heating pipework (22mm o.d) to the respective valves, right hand = flow, left hand = return, and tighten the nuts.
- 5.6.5** **Safety Valve Discharge**
The safety valve is located beneath the pump. It has a threaded outlet Rc 1/2 (1/2in BSP Int) to permit a discharge pipe to be connected.

When connecting, ensure the discharge pipe does not restrict access to or operation of the central heating valves. The discharge should terminate facing downwards exterior to the building in a position where discharging (possible boiling) water will not create danger or nuisance, but in an easily visible position.

Electrical Connections

- 5.7** The electricity supply must be as specified in clause 4.7. If controls external to the appliance are required, design of the external electrical circuits should be undertaken by a competent person.
See Section 10 for further advice.
N.B. IT IS ESSENTIAL THAT ALL EXTERNAL CONTROL CIRCUITS AND WIRING IS WIRED FROM THE SAME ELECTRICAL ISOLATOR AS SERVES THE APPLIANCE.
Factory fitted internal wiring must not be disturbed when wiring external controls.
- 5.7.1** To gain access to the electrical terminals hinge down the spring loaded control fascia. (ref to fig. 19) until it rests in an approximately horizontal position.
Press in the sides of the printed circuit board cover (fig. 20) to release retaining clips, and lift cover off.
The terminal block is easily visible on the left of the printed circuit board (fig. 21)
- 5.7.2** The electricity supply cable from the isolator and the appliance terminal block must be 3 core flexible sized 0.75mm² (24 x 0.2mm) to table 15-16, BS6500.
- 5.7.3** Wiring to the appliance should be rated for operation in contact with surface up to 90°C
- 5.7.4** Pass the cable through the cord anchorage and connect the wires Brown to L Blue to N and Green/Yellow to the Earth screw
arrange the wires so that should the cable slip the anchorage the current carrying conductors become taut before the earthing conductor. (fig. 21)
- 5.7.5** Securely tighten all terminal screws and arrange the cable with slack between the anchor and the terminal block. Tighten the cord anchorage screw until the cable is secure.
- 5.7.6** Neatly arrange the external cable in such a way that unrestricted opening of the controls fascia is possible without strain on the cable.
- 5.7.7** External controls may be wired from terminals 1 & 3 (after removing a factory fitted link). If a neutral is needed use the terminal mark N.
If required pass this cable through the same cord anchorage.
The conductors should be so connected that the conductor to terminal 1 becomes taut before those to 3 & N should the cable be strained.

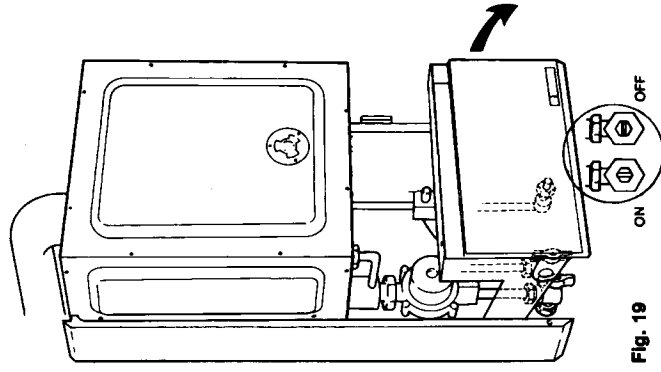

Fig. 19

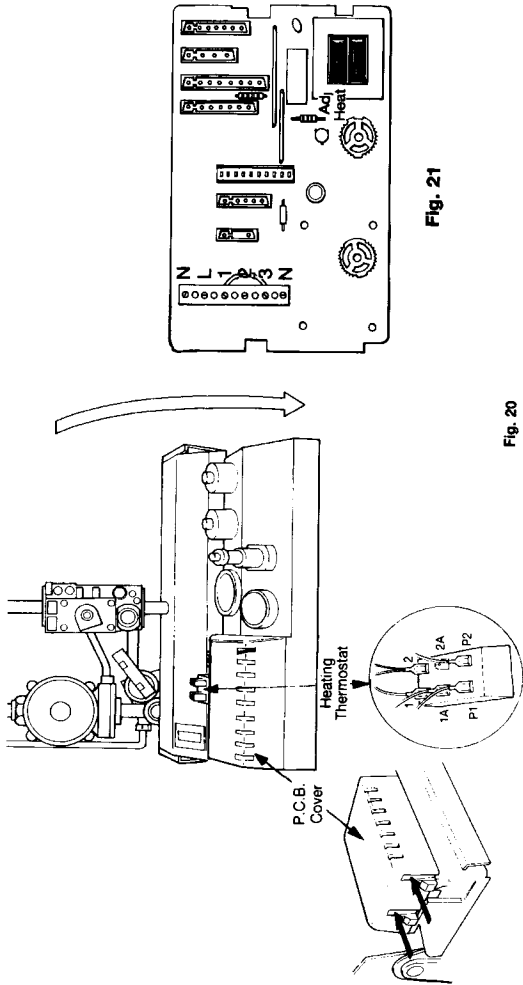

Fig. 21

Fig. 20

SECTION 6 COMMISSIONING

- 6.1** Where the text bears identifying numbers in brackets, refer to figs. 1 and 2 unless otherwise instructed. Close control panel, open controls cover.
- 6.2 Gas Supply Installation**
Inspect the entire installation including the meter, test for soundness and purge, all as described in BS6891:1988.
- 6.3 Central Heating Systems**
- 6.3.1 IMPORTANT**
DO NOT RELEASE AIR FROM THE RED SEALED EXPANSION TANK. It is charged with air at the factory to 1 bar (15psig)
- 6.3.2 Initial Flushing of the Pipework**
The appliance contains components likely to be damaged or blocked by grease and dirt from the system. It is recommended therefore that the appliance be disconnected from the system for the initial flush.
- 6.3.2.1** Close the appliance central heating valves and disconnect from the appliance (27 and 28, Fig. 1).
- 6.3.2.2** Connect a temporary water supply to the return and a drain pipe to the flow and flush the entire system until the drain discharges clean water for at least five minutes).
- 6.3.2.3** Drain the system by opening the drain taps at all low points. Close the drain taps and reconnect the flow and return valves to the appliance.
- 6.3.3 Initial filling of the System**
- 6.3.3.1** See Clause 3.4.4 and 4.6.8
- 6.3.3.2** Open central heating flow and return valves (red handle vertical indicates open, horizontal indicates closed). Unscrew black cap on automatic air release valve (21) one full turn (leave open permanently).
- 6.3.3.3** Close all air release taps on the central heating system.
- 6.3.3.4** Gradually open stopcocks at the filling point connection to the central heating system until water is heard to flow. Do not open fully.
- 6.3.3.5** Starting with the lowest radiator open each air release tap in turn closing it only when clear water, free of bubbles, flows out. In the same way release air from any high points in the pipework.
- 6.3.3.6** Continue filling the system until at least 1.5 bar registers on the gauge (9) then turn off the filling point stopcocks.
- 6.3.3.7** Inspect the system for water soundness and remedy any leaks discovered.
- 6.3.4 Setting the System Design Pressure**
- 6.3.4.1** The design pressure must be a minimum of 1 bar and maximum 1.5bar.
- 6.3.4.2** The actual reading should ideally be 1 bar plus the equivalent height in meters to the highest point of the system above the base of the appliance (up to the maximum of 1.5bar total).
N.B. The safety valve is set to lift at 3bar / 30m /45psig.

6.3.4.3 To lower the system pressure to the required value turn the red knob of the safety valve (15) a quarter turn to release water until the required figure registers on the gauge (9).

6.4 Checking Electricity Supply

- 6.4.1** Carry out preliminary checks for earth continuity, polarity, short circuit and resistance to earth. Gaining access as required according to clause 5.7.2 in this manual.
- 6.4.2** Leave the appliance with the control fascia closed and with the mains electricity switched OFF

6.6 Lighting the Boiler

- 6.6.1** Before lighting, open flow and return valves (Cl 6.3.3.2)
If external controls are fitted (e.g. timeclock and thermostat) ensure they 'call for heat'. The commissioning of the appliance may be easier if the external controls are temporarily disconnected and terminals 1 & 3 linked. (For access procedure turn off electricity and refer to clause 5.7.2 for instructions).
6.6.2 Ensure that the mains electricity and the appliance on/off switch (14) are turned on.
6.6.3 Set the control thermostat (12) to its highest setting.
6.6.4 Set the Mode Selector switch (13) to constant.
6.6.5 The main burner should now light.
6.6.6 N.B. The most common cause of failure to light is insufficient water flow. See cl. 4.6.3 and 6.11.2.

6.7 Check Burner Pressures

- 6.7.1** The heat inputs for high and low gas rates are factory set to the maximum values given in section 3.6 but it is necessary to check them when commissioning.
6.7.2 The maximum heat input for the central heating mode may be reduced by a simple adjustment to suit the system load.
6.7.3 Turn off the main electricity supply. Gain access to the interior as instructed in clause 5.7.2.
6.7.4 Locate the main burner pressure test point (Fig. 23) and slacken the screw half a turn in an anti clockwise direction. Attach a suitable pressure gauge. Turn on the main electricity supply, turn on the boiler and adjust the thermostat to the maximum setting.
6.7.5 The pressure reading for maximum rate should be 9.5mbar/3.8in wg (plus or minus 0.9mbar/0.4in wg)
If the pressure is wrong it should be adjusted as instructed in clause 8.20 (N.B. Whenever the maximum rate is adjusted check and adjust the minimum rate too)
6.7.6 If the boiler temperature is above 45°C turn the thermostat down until the low flame is established. If low flame cannot be established in this way, turn off the electricity supply and transfer the cable on terminal 1 of the thermostat to terminal 1A (Fig. 20 shows location). Switch on electricity.
6.7.7 When low flame is established, the pressure gauge should read 1.2mbar/0.5in wg (plus or minus 0.1 mbar/0.05in wg). If it is different, adjustment should be made in accordance with the instructions in clause 8.20.2.
6.7.8 If the thermostat connection has been transposed to obtain low flame (cl 6.7.6), turn off the mains electricity and replace the cable on terminal 1.

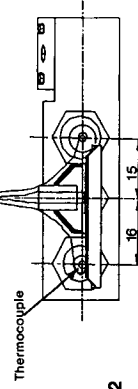

Fig. 22

6.7.9 Setting the Maximum Rate for Central Heating (Range Rating)

Refer to fig. 24 to determine pressure for the heating output you need. Use a screwdriver to adjust the potentiometer (fig. 21) until the required pressure is indicated on the gauge. Once this pressure has been fixed it should be indelibly recorded on the label provided and affixed next to the data badge. This is to ensure that the burner can be reset when any service operation involves alteration of burner settings.

6.8 Checking the Flue System
 6.8.1 The flue system should be visually checked for soundness. Check all clamps and fixings are secure and tight.

6.9 Checking the Heating Thermostat
 6.9.1 Allow the system to warm up and manipulate the c/h thermostat to ensure the burner switches from 'high' to 'low' and 'low' to 'off' and vice versa (scale range covers approx. 45°C - 85°C).

6.10 Checking the operation of the Flame Failure Device
 6.10.1 With the burner on high flame, turn the gas knob in a clockwise direction and confirm that a definite 'click' is heard. Relight pilot (6.5.4), Fig. 23

6.11 Regulating the Central Heating System
 6.11.1 Fully open all radiator and circuit valves and run the appliance in the central heating mode until heated water is circulating. If conditions are warm, remove any thermostatic valve heads.

6.11.2 If the burner will not light, ensure that water is in fact circulating. See cl. 4.6.3

6.11.3 Adjust radiator return valves and any branch circuit return valves until the individual return temperatures are correct and are approximately equal.

6.11.4 When all is adjusted, progressively close all radiator valves to ensure that the appliance still operates when flow through the system is limited.

If the burner cuts out prematurely due to lack of water flow through the appliance, the system should be regulated to ensure a flow rate of at least 350 litres/hour (1.28 gals/min).

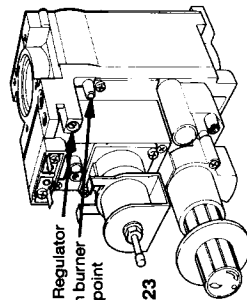

Fig. 23

6.12 Final Flushing of the Heating System
 6.12.1 After the system has been thoroughly heated to about 60°C (140°F) or above, and hot water has circulated to all parts, any residual grease, flux and other foreign material will have been dislodged.

6.12.2 Inspect the system for soundness. Turn the appliance off and turn off the on/off switch (fig 1 No.14). Open all drain taps and quickly drain the system whilst still hot to remove offending substances. Refill as instructed in clause 6.3.3.

6.13 Final Check for Operations
 Turn off at the ON/OFF switch, disconnect pressure gauge, retighten screw. Relight boiler.

6.13.1 Re-check for gas soundness
 6.13.2 Re-examine heating system for water soundness.

6.13.3 Check the appearance of the pilot and gas flame to assess adequacy of combustion air supply.

6.13.4 Re-check the flue system for soundness and adequacy of supports.

6.14 Concluding Operations
 6.14.1 If external controls have been disconnected and terminals 1 & 3 temporarily linked, remove the link and reconnect the external control circuit, check the operation of the external controls.

6.14.2 Hinge up the control fascia.

6.15 Refixing the Front Cover (fig. 25)
 6.15.1 Offer up the front casing to the back frame in a near vertical attitude and locate the hooks on the casing over the hooks on the frame. Slide the casing downwards to fully engage the hooks and to align the bottom fixing holes. Replace the four case retaining screws, fig. 25).

6.16 Supplementary Instructions for Fitting & Removing Optional Time Clock and for Wiring to External Controls.
 Section 10 Appendices A, B and C at the rear of this manual provides full instructions for fitting and wiring the optional built-in time switches and for wiring to external controls.

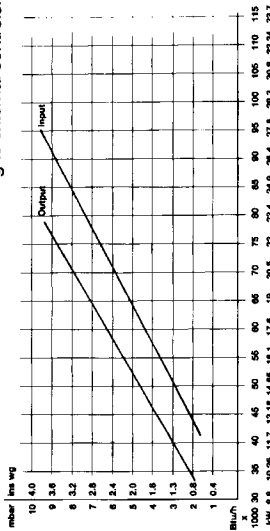

Fig. 24

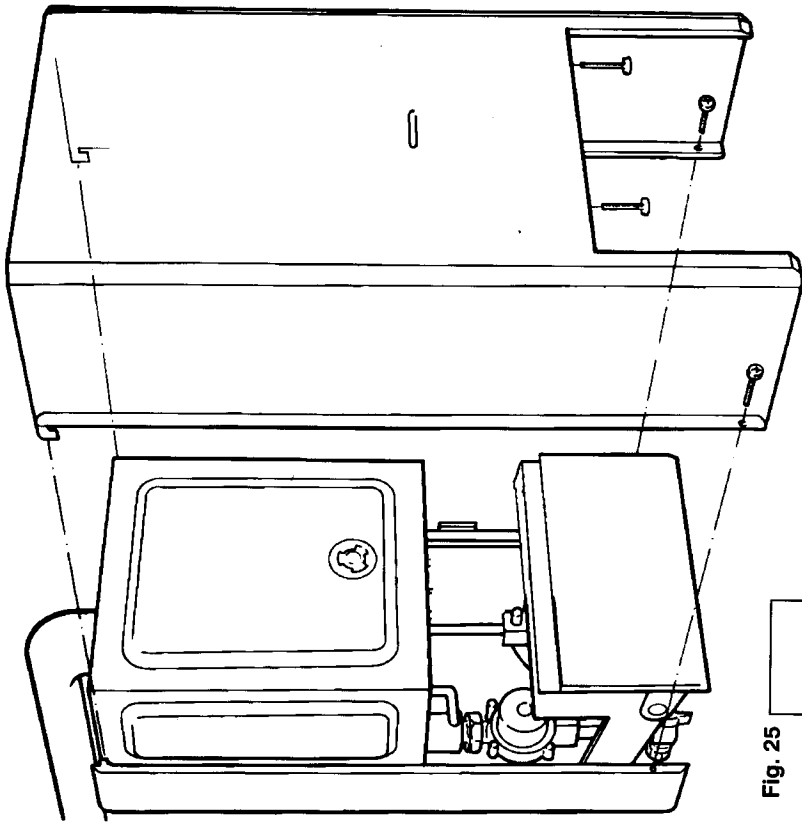

Fig. 25

SECTION 7 INSTRUCTING THE USER

- 7.1 Hand over the copy of the Users Instructions supplied with the appliance, together with these instructions, and explain how to operate the boiler correctly and explain how to use the timeclock and room thermostat if fitted.
- 7.2 Show the user how to switch off the appliance quickly and indicate the position of the electric supply isolator.
- 7.3 Explain that air supply grilles must not be blocked in any way.
- 7.4 Inform the user of the location of all drain cocks and air vents.
- 7.5 Explain how to turn the appliance off for both short and long periods and advise on the precautions necessary to prevent damage should the appliance be inoperative when freezing conditions may occur.
- 7.6 Finally, advise the User that, for continued safe and efficient operation, the appliance must be serviced by a competent person at least once a year.

SECTION 8 SERVICING INSTRUCTIONS

8.1

GENERAL

To ensure efficient safe operation of the appliance it is necessary to carry out routine servicing at regular intervals.

The frequency of servicing will depend upon the particular installation conditions and the use to which the boiler is put; but, in general, once per year should be adequate. It is the law that any service work must be carried out by a competent person such as British Gas or other recognised companies.

The following instructions apply to the boiler and its controls, but it should be remembered that the central heating and system will also require attention from time to time.

8.2

IMPORTANT NOTES

WARNING: Having carried out a preliminary flame check and before starting any servicing work, switch OFF the mains electricity supply and disconnect the plug at the main isolating switch and socket. (If a switch is used remove the fuse.)

Turn off gas supply at the gas service tap fitted to the appliance.

Always test for gas soundness after any service work and after exchanging any gas carrying component.

8.3

RECOMMENDED ROUTINE SERVICING

8.3.1 ANNUAL SERVICING
The following procedures should be carried out at least once per year.

- Inspect exterior for signs of damage and deterioration particularly of flue pipework and electrical connections.
- Inspect air supply and ventilation arrangements comparing them with the requirements laid down in clause 4.5 to ensure no alterations have been made since installation.
- Turn off mains electricity and remove front casing (see clause 8.4).
- Replace fuse if previously removed (8.2 above) and turn on electricity, run the boiler for a few minutes to permit inspection of its operation. This is accomplished by turning on the appliance and inspecting the burner through the pilot sight glass for yellowing of flame tip, flame lift off or sooting.
- Ensure central heating valves (fig. 1) are open. Note these are 1/4 turn valves which are open when handle is vertical, closed when handle is horizontal. Observe pressure gauge reading (fig. 1) which should be approximately 1 bar when the system is cold (see clause 6.3.4)

- Turn off mains electricity and turn off gas service tap on the appliance.
- Gain general access as described below in clause 8.4.
- Remove pilot burner assembly and brush clean. Inspect pilot injector and blow clean (see clause 8.6.3).
- Remove main burner, cl 8.7.1 to 8.7.6. Lightly clean with a soft brush and inspect for damage. If during initial inspection, any combustion irregularity was suspected, remove injectors and clean or replace (see clauses 8.8).
- Place cloth below combustion chamber to catch debris. Clean heat exchanger using suitable brushes and rods if necessary.
- Inspect combustion chamber lining. The insulating material is easily damaged. Do not scrape, but clean off lightly.
If any panels are damaged these should be replaced (see Clause 8.12).
- Replace all parts in reverse order but leave the controls fascia open and outer casing off.
- Undertake a complete commissioning check as detailed in section 6.
- Close up control fascia and refix front casing.
- Clean off casing using soft cloth and dilute detergent.

REPLACEMENT OF PARTS

The life of individual components varies and they will need servicing as and when faults develop. The fault finding sequence charts in section 9 will serve to locate which component is the cause of any malfunction, and instructions for removal, inspection and replacement of the individual parts are given in the following pages.

TO GAIN GENERAL ACCESS

To remove components access to the interior is essential. Refer to figs. 26 & 27. Ensure electricity supply is isolated before carrying out any servicing.

To remove front casing

Release 4 retaining screws (fig. 26). Pull bottom of case slightly forward and push case upwards to disengage from top support hooks and withdraw the case from the appliance.

The control panel can now be hinged down for access.

Remove 4 vertical screws and pull lower plastic grill downwards.

8.5 ROOM SEALED CHAMBER FRONT COVER (including viewing window)

- Part No 5904 Refer to fig 28
- Gain general access as 8.4
- Remove roomsealed front cover plate by releasing eight screws (fig. 26) and easing cover off. The screws are not captive. Inspect gasket for damage. If damaged, replace.
- 8.5.1** Gain general access as 8.4
- 8.5.2** Remove roomsealed front cover plate by releasing eight screws (fig. 26) and easing cover off. The screws are not captive. Inspect gasket for damage. If damaged, replace.

8.6 TO REMOVE/REPLACE ELECTRODE, THERMOCOUPLE AND PILOT BURNER

- Refer to fig. 30 A
- Gain general access as 8.4
- Remove room-sealed chamber front cover plate as 8.5.2

TO REMOVE PILOT BURNER ASSEMBLY

- Pull off electrode lead.
- Disconnect pilot pipe and thermocouple at gas valve end.
- 8.6.3.1** Release screw securing pilot burner assembly. (fig. 30 A).
- Ease pilot burner assembly and pipe forward, sliding rubber gasket from frame.
- Remove electrode, Thermocouple and pilot pipe.

REMOVE ELECTRODE

- Pull off electrode lead.
- Unscrew electrode retaining nut.
- Remove electrode.
- Reassemble in reverse order.

TO REMOVE/REPLACE THERMOCOUPLE

- Remove pilot burner assembly (8.6.3).
- Unscrew retaining nut at burner end and pull out probe. Ease it through the rubber gasket. (N.B. Retaining nut is compression fit and slides off the probe in an upward direction.)

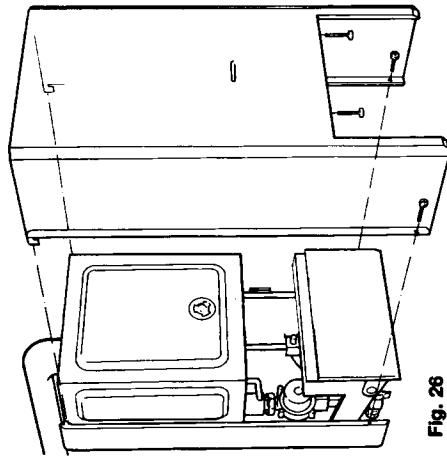

Fig. 26

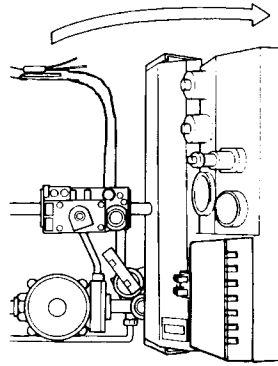

Fig. 27

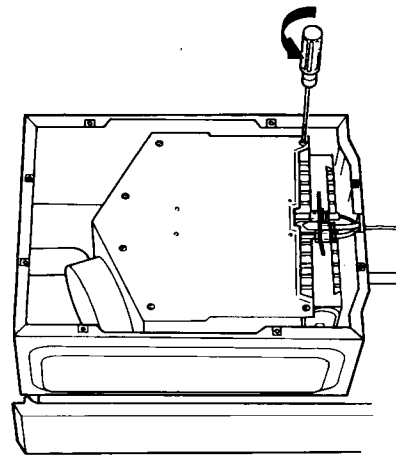
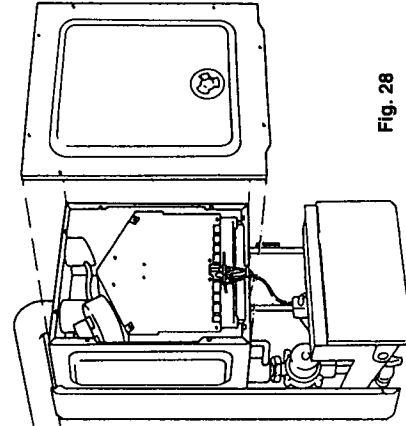

Fig. 28



8.6.5.2 If a new thermocouple is to be fitted, bend it to approximate shape of old one and replace in reverse order. N.B. Make sure rubber gasket is intact and properly fitted to boiler case so as to be air tight.

8.6.6 TO REMOVE/REPLACE PILOT BURNER AND/OR INJECTOR

- 8.6.6.1** Remove pilot assembly (8.6.3).
- 8.6.6.2** Remove electrode and thermocouple.
- 8.6.6.3** Unscrew pilot supply pipe union, and withdraw pipe. N.B. Pilot injector is held captive by bush on the end of the connecting pipe. It will drop out as pipe is removed. Reassemble in reverse order.

8.7 MAIN BURNER

Part No 5295
Refer to fig 30

- 8.7.1** Gain general access as 8.4
- 8.7.2** Remove room-sealed front cover as 8.5.2.
- 8.7.3** Remove front of combustion chamber by releasing six screws (fig 29)
- 8.7.4** Remove pilot burner assembly as 8.6.3
- 8.7.5** Remove four burner retaining screws (see fig 30)
- 8.7.6** Remove main burner.
Reassemble in reverse order.

8.8 MAIN BURNER INJECTORS

- 8.8.1** Gain general access as 8.4
- 8.8.2** Remove room-sealed front cover plate and combustion chamber front (8.5.2 & 8.7.3).
- 8.8.3** Remove main burner (8.7.4 to 8.7.6).
- 8.8.4** Unscrew injector(s).
Reassemble in reverse order.

8.9 MAIN HEAT EXCHANGER

Part no. 5357

- 8.9.1** Refer to fig. 30
- 8.9.2** Gain general access as 8.4.
- 8.9.3** Remove roomsealed front cover plate (8.5.2).
- 8.9.4** Remove front of combustion chamber. (8.7.3)
- 8.9.5** Close heating valves (1/4 turn until handle is horizontal). Turn safety valve 1/4 turn to drain primary circuit of boiler.
- 8.9.6** Place cloth under heat exchanger to catch surplus water.
- 8.9.7** Unscrew unions on either side of main heat exchanger. (fig. 30).
- 8.9.8** Slide out main heat exchanger, taking care not to damage insulation panels. Avoid spillage of water on boiler electric.
- 8.9.9** Reassemble in reverse order using new fibre washers on unions.

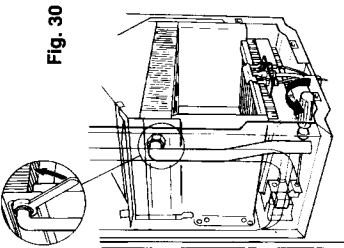

Fig. 30a

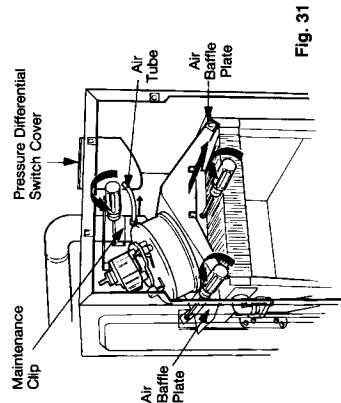

Fig. 31

8.10 FLUE FAN

Part No 5970

- 8.10.1** Gain general access as 8.4. Remove room-sealed front cover plate (8.5.2) and front of combustion chamber (8.7.3).
- 8.10.2** Loosen maintenance clip securing screws (see fig. 31) and slide upwards to clear joint.
- 8.10.3** Remove silicone pipe from nozzle on inner flue bend.
Remove 3 flue hood retaining screws (see fig. 31)
- 8.10.5** NOTE: When removing the two side screws the two air baffle plates can be removed. Carefully slide flue hood forward disconnecting electrical leads on fan in the process.
- 8.10.6** Unscrew 4 screws securing fan to flue hood and remove fan.
- 8.10.7** Reassemble in reverse order, replacing centre hood screw first.

8.11 FLUE PRESSURE DIFFERENTIAL SWITCH

- 8.11.1** Refer to fig 31
Part No 5926
Remove front casing (8.4.1).
- 8.11.2** Remove room sealed cover (8.5.2).
Remove 3 screws holding pressure differential switch cover (fig. 31) and remove cover.
- 8.11.3** Pull air tube from nozzle on inner flue bend.
- 8.11.4** Pull off tab connectors and ease pressure switch upwards. Disconnecting air pressure pipe in the process.
- 8.11.5** Reassemble in reverse order.

See fig 44 for correct fitting of electrical connections. The air pipe must be reconnected to the upper nozzle on the pressure switch.

8.12 COMBUSTION CHAMBER INSULATION BOARDS

- 8.12.1** Gain general access as 8.4
- 8.12.2** Remove room-sealed front cover 8.5.2
Remove front of combustion chamber 8.7.3
Close Heating Valves 8.9.4
Remove Main Heat Exchanger 8.9

To remove side combustion chamber insulation boards. Gently prise upwards and pull out.

To remove rear board. Gently prise upwards and pull out.

Fourth panel (front) is replaced complete with combustion chamber front panel.

8.13 TO REMOVE/REPLACE GAS CONTROL VALVE MODULATOR AND OPERATOR

- Refer to fig. 32
- 8.13.1** Gain general access (8.4)
- 8.13.2 MODULATOR COIL**
- 8.13.2.1** Pull of electrical leads from tab connectors.
- 8.13.2.2** Slacken locknut, unscrew max. rate adjustment screw and remove (NB take care of spring).

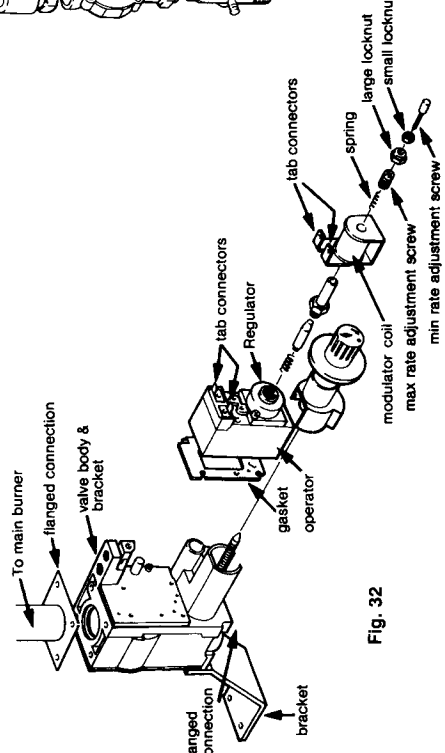

Fig. 32

Fig. 33

- 8.13.2.3** Remove modulator coil.
- 8.13.2.4** Replace in reverse order (see fig. 44 for electrical connections).
- 8.13.2.5** Check burner pressures (cl 6.7).
- 6.13.3 OPERATOR**
- 8.13.3.1** Pull off all electrical leads from modulator and operator tab connectors. Disconnect earth lead.
- 8.13.3.2** Remove modulator coil (8.13.2)
- 8.13.3.3** Release 4 screws securing operator to gas valve body (2 at top below tab connectors 2 at bottom extreme corners).
- 8.13.3.4** Remove operator, exposing gasket.
- 8.13.3.5** Replace in reverse order using new gasket (see fig. 44 for electrical connections).
- 8.13.3.6** Check burner pressures (cl. 6.7).
- 8.13.4 GAS CONTROL VALVE**
- 8.13.4.1** Remove modulator coil and operator as detailed above. The operator etc. can be transferred to any new valve to retain regulation settings.
- 8.13.4.2** Disconnect thermocouple and pilot supply pipe connections. Pull interruptor lead from valve.
- 8.13.4.3** Remove screws securing bracket to base frame.
- 8.13.4.4** Remove 4 flange securing screws at each end, and withdraw valve (this may be easier with gas pipe disconnected from main burner), disconnecting second interruptor lead in the process.
- 8.13.4.5** Replace in reverse order using new gaskets.
- 8.13.4.6** Test all disturbed joints for gas soundness. Check burner pressures (cl 6.7). If incorrect, adjust as instructed in cl 8.24).

- 8.14 PUMP**
Part No 6090
Refer fig 33
- 8.14.1** Gain general access as 8.4
- 8.14.2** Close heating valves and return valves fig 1, 27 & 28) by turning 1/4 turn until handles are horizontal.
- 8.14.3** Drain appliance via safety valve by 1/4 turn of safety valve knob.
- 8.14.4** Disconnect pipe union connection at front left corner of combustion chamber.
- 8.14.5** Disconnect top union on pump and remove pipe and air separator assembly from the pump.
- 8.14.6** Grasp pump and pull upwards with a slight twisting movement to release pump from manifold.
- 8.14.7** Disconnect electrical leads from pump.
- 8.14.8** Reassemble in reverse order.
Reconnect electrical leads. Brown to L, Blue to N and Green to E.
- 8.15 HEATING MANIFOLD**
Part No . 3175 Refer to fig. 34
- 8.15.1** Remove pump as 8.14.
- 8.15.2** Disconnect safety valve discharge pipe and heating valve unions.
- 8.15.3** Remove retaining screw (securing manifold to frame).
- 8.15.4** Disconnect expansion vessel pipe union, pressure gauge connection, heating flow and return unions and heating thermostat sensor.
- 8.15.5** Unscrew and remove retaining nut and remove micro switch.
- 8.15.6** Remove manifold
- MANIFOLD ASSEMBLY**
Release cover retaining screws and ease off with a screwdriver.
Refer to fig. 34 for location of components.
Replace in reverse order, ensuring that washers are replaced in all union connections.
- 8.16 CHECKING/REPLACING MAIN EXPANSION VESSEL**
The expansion vessel is factory pressurised to 1 bar (14.7psi) and should be checked during servicing. Should it have lost pressure it can be repressurised in situ. Drain the boiler. Fit a suitable pump and gauge (ie car foot pump and gauge) to the nipple at the top right-hand side of the expansion vessel, and pressurise to 1 bar (14.7psi) and remove the pump.
If the vessel cannot be repressurised or if pressure loss is very frequent the expansion vessel will require changing. Alternatively, a new vessel can be fitted in the return to the appliance.
- 8.17 SAFETY VALVE**
Gain General Access 8.4.
- 8.17.1** Drain down primary side of boiler by closing heating valves (1/4 turn until handle is horizontal). Turn safety valve 1/4 turn to drain appliance.
- 8.17.2** Drain down primary side of boiler by closing heating valves (1/4 turn until handle is horizontal). Turn safety valve 1/4 turn to drain appliance.
- 8.17.3** Remove Heating Microswitch as 8.18.2.
- 8.17.4** Unscrew safety valve discharge pipe.
- 8.17.5** Unscrew complete valve from Heating Manifold.
Replace in reverse order.
- 8.18 REMOVAL OF ELECTRICAL COMPONENTS**
Ensure electricity is switched off at main isolator and gain general access (8.4)
- 8.18.1** **HEATING MICROSWITCH**
Part No 4302
Refer to fig. 34
- 8.18.2** Hold switch and unscrew retaining nut.
- 8.18.3** Remove switch and remove cover.
- 8.18.4** Pull off electrical tab connections.
- 8.18.5** Reassemble in reverse order.
- 8.18.6** **HIGH LIMIT THERMOSTAT (THERMOCOUPLE INTERRUPTOR)**
Part No 5472
Refer to fig. 39
- 8.18.7** Disconnect 2 electrical connections at Gas Control Valve.
- 8.18.8** Disconnect 2 electrical connections at Gas Control Valve.
- 8.18.9** Ease off Thermostat retaining clip on flow tube.
- 8.18.10** Reassemble in reverse order.
- 8.18.11 HEATING THERMOSTAT**
Part No 3212
Refer to figs 38 & 39
- 8.18.12** Drain down primary side of boiler by closing heating valves (1/4 turn until handle is horizontal). Turn safety valve 1/4 turn to drain appliance.
- 8.18.13** Trace capillary tube to heating manifold unscrew sensing probe retaining nut and withdraw probe.
- 8.18.14** Pull electrical tabs off back of thermostat.
- 8.18.15** Pull knob off front revealing 2 retaining screws.
- 8.18.16** Remove screws to release thermostat and remove.
- 8.18.17** Reassemble in reverse order using a new fibre washer.
- 8.18.18** Refer to figs 38 & 39 to ensure correction location of thermostat and push-on wiring tabs.
- NB** When changing this thermostat it may be necessary to repressurise the system (section 6.3.3 gives details).

N.B. If the boiler is installed with a clearance above of 343mm (13.5in) or more and with a side exit flue it is possible to remove the expansion vessel in situ, follow steps 8.16.10 - 18.16.11

If the clearance above is less than 343mm (13.5in) or, with a back exit flue, it is not possible to remove the expansion vessel in situ, follow steps 8.16.2 - 8.16.11

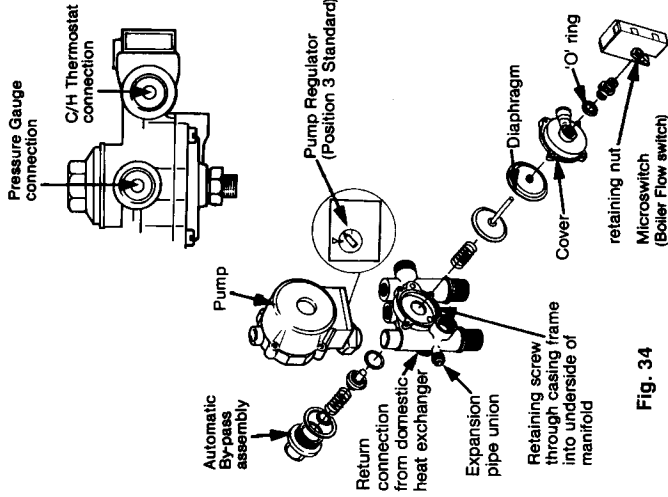

Fig. 34

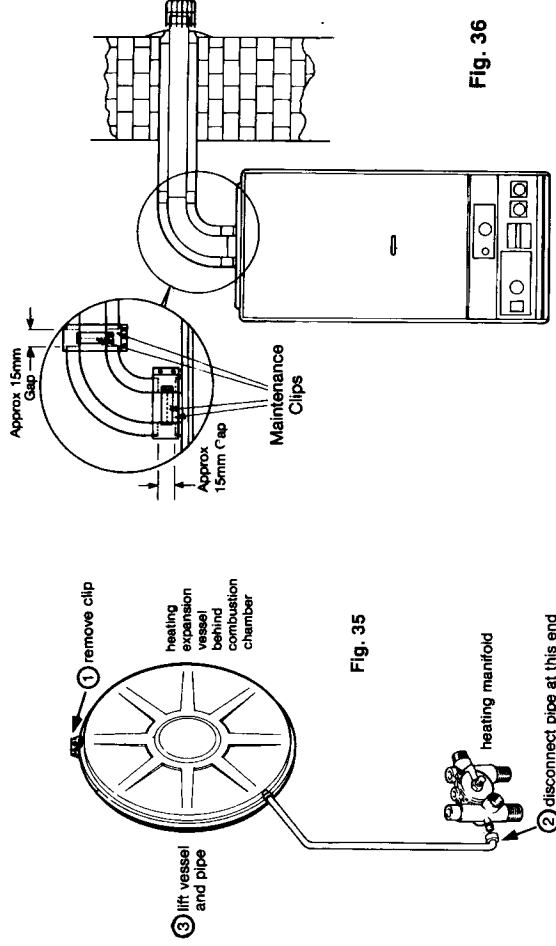

Fig. 35

Fig. 36

8.18.19 REMOVAL OF PRINTED CIRCUIT BOARD

Part No 5797
Refer to fig. 39

8.18.20 Press in the sides of the printed circuit board cover (fig. 39) to release retaining clips and lift cover off.

8.18.21 Disconnect external incoming live and neutral and any control wiring from terminal strip.

8.18.22 Remove 6 plugs from p.c.b

8.18.23 Pull tab connectors off both rocker switches.

8.18.24 Pull back p.c.b retaining lugs and remove p.c.b.

8.18.25 Replace in reverse order

8.18.26 Replace electrical connections. Refer to fig. 44 to ensure correct locations of switch wires.

8.18.27 SWITCHES (ON/OFF and TIMED/ REST/ CONSTANT or MODE SELECTOR

Part No's 5284 & 4981
Refer to fig. 37

8.18.28 Pull of tab connectors, squeeze spring latching tabs at the back of the panel and push switch outwards.

8.18.29 To replace refer to fig 37 to ensure switch is in correct attitude and press into hole from the front until spring tabs latch. Refer to fig 37. for correct wiring details.

8.18.30 FAN FLOW SPEED RESISTOR

8.18.31 Unplug inline connector below fan resistor.

8.18.32 Remove 2 retaining screws from resistor.

8.18.33 Replace in reverse order.

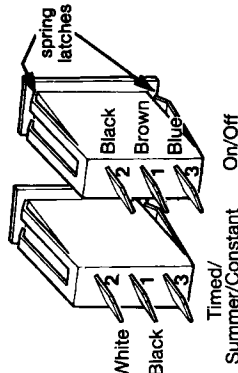

Fig. 37

White
Black
Blue

Timed/
Summer/Constant
On/Off

Fig. 38

spring latches
P.C.B. retaining lugs

8.19 REMOVAL OF MECHANICAL INSTRUMENTS AND COMPONENTS.

8.19.1 PRESSURE GAUGE

Part No 5263
Refer to figs. 34 & 40

8.19.2 Close central heating flow and return valves, by 1/4 turn to horizontal position, drain appliance through the safety valve by 1/4 turn of the knob.

8.19.3 Trace capillary from back of gauge to connecting point on heating manifold.

8.19.4 Unscrew union on manifold.

8.22.5 Remove and clean off washer remnants.

8.19.6 Squeeze plastic locking lugs behind fascia and press gauge from aperture.

8.19.7 Refix in reverse order following original route for capillary.

8.19.8 TEMPERATURE GAUGE

Part no 5262
Refer to fig. 40

8.19.9 Trace capillary to sensor. Remove purse clip and capillary tube retaining clip from flow tube and withdraw sensor.

8.19.10 Squeeze plastic locking lugs behind fascia and press gauge from aperture.

8.19.11 Re-assemble in reverse order ensuring locking lugs are located in the grooves, and capillary clip is refixed.

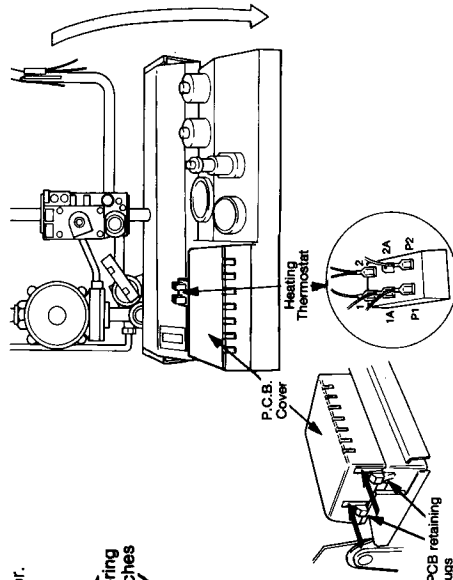

Fig. 39

8.20

SETTING GAS PRESSURES

ALL SETTINGS DONE WITH "U" GAUGE FITTED TO BURNER TEST NIPPLE AS INSTRUCTED IN CLAUSE 6.6

8.20.1 SETTING MAXIMUM RATE

Turn off electrical supply to boiler and follow instructions in section 8.4 to gain access.

Refer to Fig. 41

Loosen small locknut. Unscrew completely the fine adjusting screw, if not already on, turn on hot water tap and electrical supply.

Adjust main gas pressure by loosening 10mm nut and turning slotted screw clockwise to increase pressure. Anticlockwise to decrease (set pressure to 9.5 mbar/3.8in wg) plus or minus 0.95mbar/0.4in wg.

Carefully tighten lock nut without altering setting.

Turn off tap and electrical supply.

Replace fine adjusting screw.

8.20.2

SETTING MINIMUM RATE

Remove wire on terminal No. 1 of thermostat and replace on terminal No 1A (see fig. 39).

Turn on electrical supply. Turn on the boiler, the boiler will light up at low flame. Adjust pressure using fine adjusting screw turn clockwise to increase anticlockwise to decrease (set pressure at 1.2mbar/0.48in wg) plus or minus 0.1 mbar/ 0.05in wg.

Tighten locknut.

Turn off boiler. Turn off electrical supply.

Remove wire on terminal No 1A on thermostat and replace on terminal No 1.

8.20.3 CENTRAL HEATING (RANGE RATING) TO SET MAXIMUM RATE IN CENTRAL HEATING MODE.

See clause 6.7.9 for necessary adjustments. Refer to the commissioning rate recorded by the commissioning engineer on the boiler badge.

8.21

END OF SERVICING

Run through the general commissioning as described in Section 6 as far as they apply. Refit casings and clean up.

Boiler thermostat sensor screws into heating manifold

Temperature gauge sensor slides into tube on flow pipe

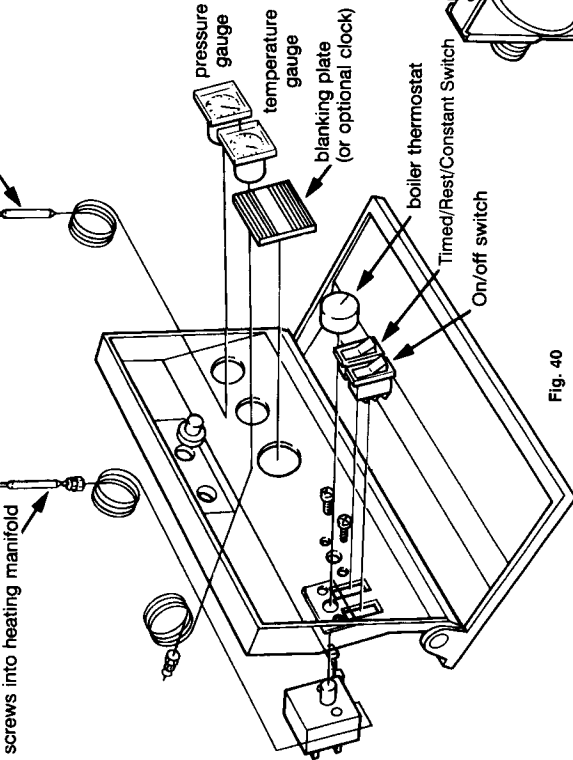
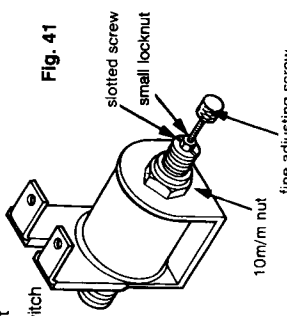

Fig. 40

Fig. 41



SECTION 9 OPERATIONAL CHECKS AND WIRING DIAGRAMS

9.1 On completion of any service/fault finding task which has required the breaking and remaking of electrical connections, carry out preliminary checks for earth continuity, polarity, short circuit and resistance to earth. Gaining access as required according to clause 5.7.2 in this manual.

The following flow diagrams suggest the logical sequence of steps for fault finding. They are not exhaustive but cover all that can reasonably be carried out on site by the installer.

Acquaintance with the functional sequence will prove helpful for some, and this is included for reference. As further help, the role of each part is briefly described.

Also included in this section are wiring diagrams and schematics to assist in fault location and servicing as described in the text.

9.2 Sequence of Functions

When following this sequence, refer to figs. 44 & 45. It is assumed that the on/off switch is ON and the pilot flame is alight.

9.2.1 At Rest

No call for Heating. Current flows via the normally closed contacts of R1, through the 560 ohm resistor then through the normally closed contacts of the boiler flow switch to the fan which runs at low speed to scavenge the combustion chamber and provide air for the pilot flame.

N.B. if the electricity supply is switched off or fails the fan will cease to operate and there may be insufficient air to maintain the pilot. A relighting of the pilot would be necessary.

9.2.2 Central Heat Mode

In this mode the timed/rest/constant switch must be in the closed i.e. constant position fig. 1.

With all controls calling for heat the pump will run, and a supply is fed through the boiler 2nd stage thermostat which will energise terminal 1 (normally closed) on the fan pressure differential switch.

The transformer is energised causing the contacts of R1 to be made. The fan will start and the pressure differential switch will change over energising the gas valve. The boiler will operate for central heating as described below.

The control circuit is via the 1st stage of the boiler thermostat when the thermostat calls for heat it is open circuit (i.e. make on rise).

Control current to the gas valve modulating coil is subject to the resistance of the potentiometer. The resulting low voltage to the coil positions the gas valve for the maximum central heating rate.

On reaching the set temperature the thermostat closes, by-passing the potentiometer and imposing maximum voltage on the modulating coil. The boiler then operates at the set minimum rate.

On reaching the set temperature the thermostat closes, by-passing the potentiometer and imposing maximum voltage on the modulating coil. The boiler then operates at the set minimum rate.

Successive operations of the thermostat regulates the average heat input to that required.

If, on low fire, the boiler temperature continues to rise the 2nd stage thermostat breaks P2-2A putting the burner circuitry back into the 'rest' mode.

P2-2 is made and so keeps the pump running to circulate to the radiators if the supply to P2 of the thermostat is broken (e.g. by a room thermostat) both the burner and pump are switched off.

Should there be a restriction in the heating circuit reducing the flow rate through the boiler to below 350 litres/hour (1.28gpm.) the boiler circuit flow switch will open and de-energise the gas valve.

FAULT FINDING STEP 1 CHECK ELECTRICAL SUPPLIES, SWITCHES & CONNECTIONS

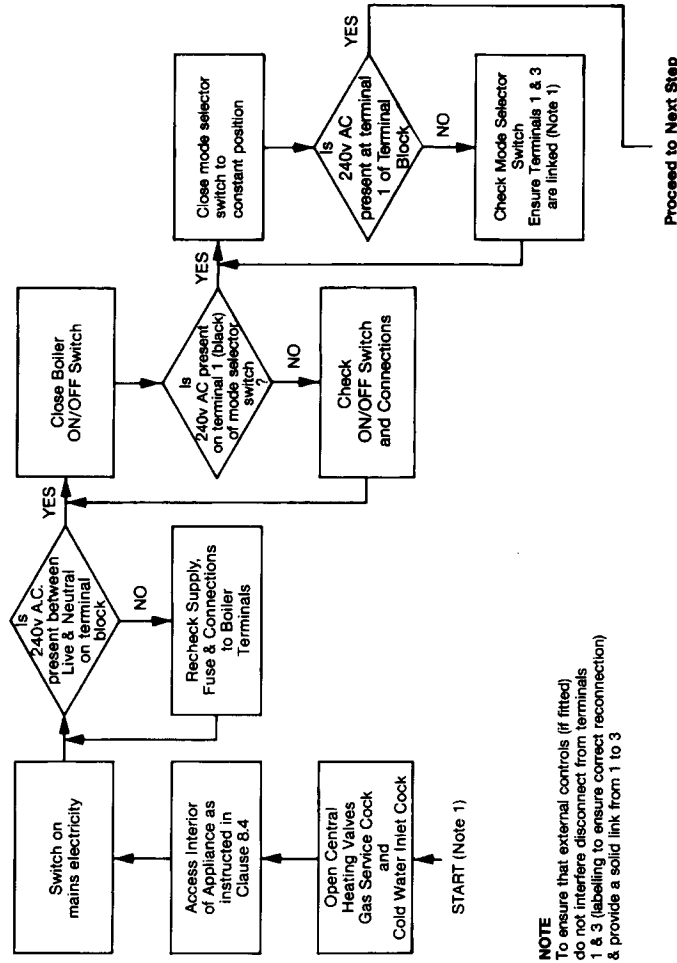

NOTE
To ensure that external controls (if fitted) do not interfere disconnect from terminals 1, 2 & 3 (labelling to ensure correct reconnection) & provide a solid link from 1 to 3

FAULT FINDING STEP 2 CHECKING C/H THERMOSTAT CIRCUITS

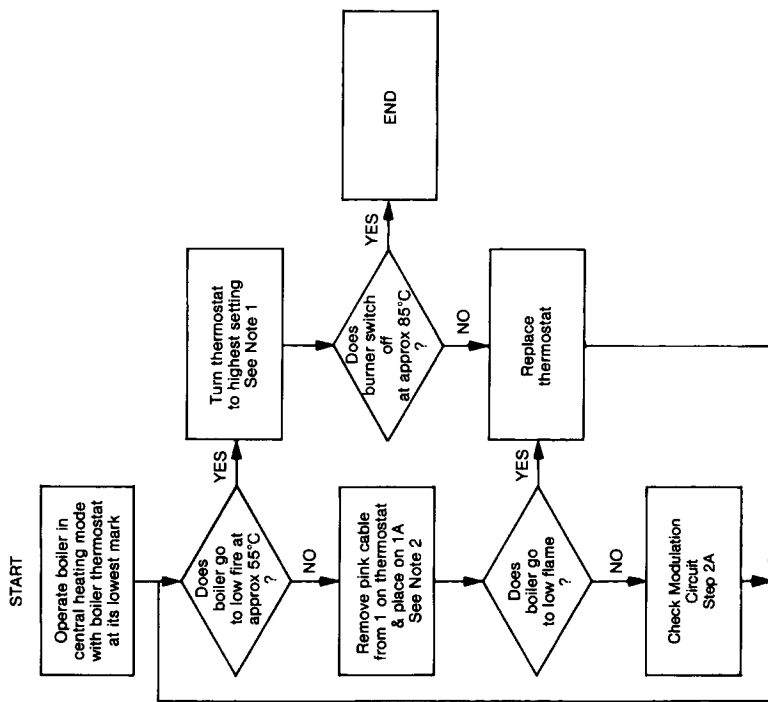

NOTES

1 Reduce number of radiators turned on to give quick response. Observe controls switch 1st to LOW and then OFF

2 IMPORTANT. Turn off electricity to make change. N.B. The white/black/brown leads are 240V AC. The pink and red leads are 12.5V DC. Do not confuse.

FAULT FINDING STEP 2A CHECK MODULATION CIRCUIT IN C/H MODE

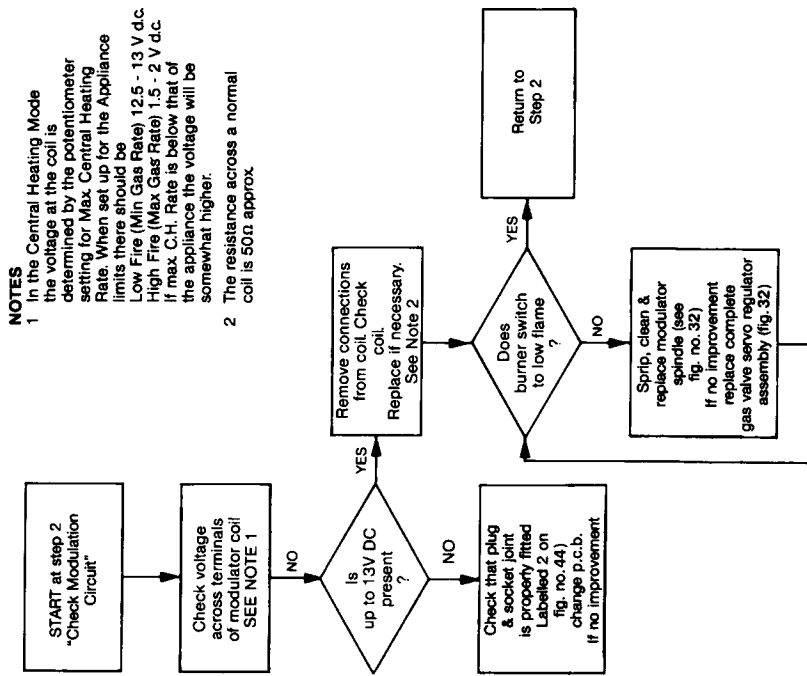

NOTES

1 In the Central Heating Mode the voltage at the coil is determined by the potentiometer setting for Max. Central Heating Rate. When set up for the Appliance limits there should be Low Fire (Min Gas Rate) 12.5 - 13 V d.c. High Fire (Max Gas Rate) 1.5 - 2 V d.c. if max. C.H. Rate is below that of the appliance the voltage will be somewhat higher.

2 The resistance across a normal coil is 50Ω approx.

Instructions for (A) Fitting Vokera 24 Hour Time Switch (Part No. 032 GC No. 301 110) and Fitting Vokera Digital 7 Day Time Switch (Part No. 05 GC No. 301 109)
(B) Wiring to external Time Switches, Room thermostats and Frost Thermostats
(C) Wiring to 'Y' plan or 'S' plan Installations

A. Installation of Vokera time switches (24hr and 7 day)

Remove the clock aperture blanking plate (1) (fig 1) by squeezing the two lugs on the rear of the plate together and push the plate out.
 Remove the clock from its box.
 Wire the clock as shown in fig. 4.
 Insert the clock into the aperture from the back of the control panel. Push the mounting bezel (2) through the front panel and secure to the clock using the four screws provided. (See fig 2)
 Connect the other ends of the wires as detailed below. (See fig 3)

White/Red: Connects to double connector on black wire on top terminal of On/Off switch.
Blue: connect to bottom terminal marked N on main terminal strip.
White: Connect to terminal 1 on main terminal strip, (leave link 1-3 connected if no room thermostat is used).
Red/Black: Connect to spare terminal on rear of timed/ rest/constant switch.
 Remove the loop between terminals 1 & 3 on the boiler terminal strip if a room stat is also fitted.

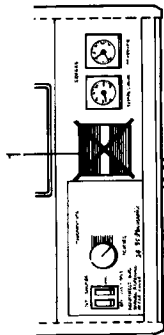

Fig. 1

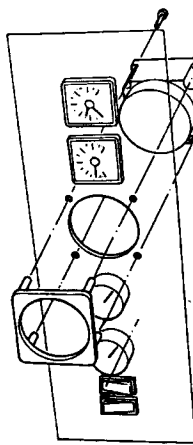

Fig. 2

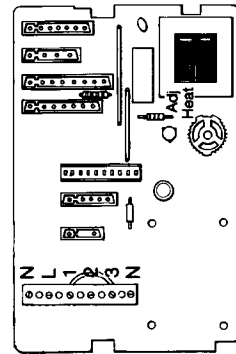

Fig. 3

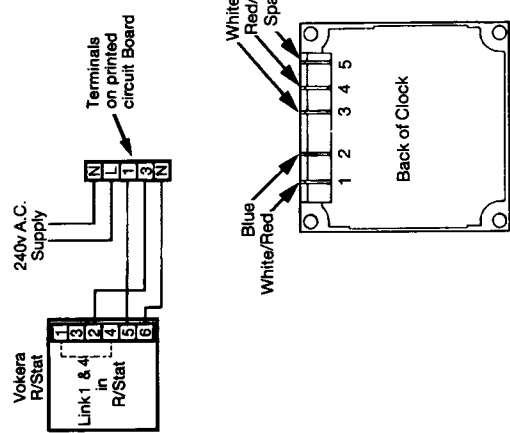
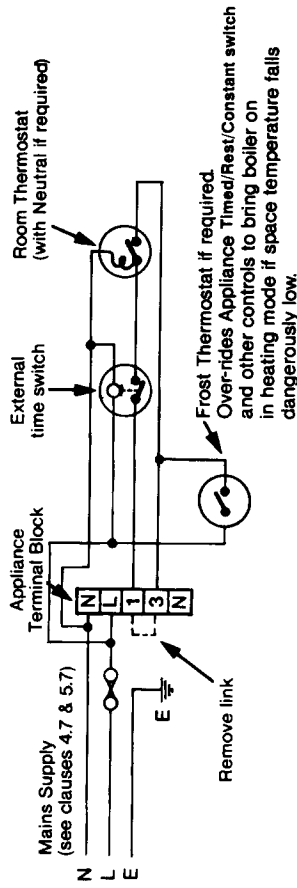

Fig. 4

B. Wiring to External Time Switches and Thermostats

(i) General Schematic Diagram.



(ii) Towerchron Time Switch Vokera Room Thermostat

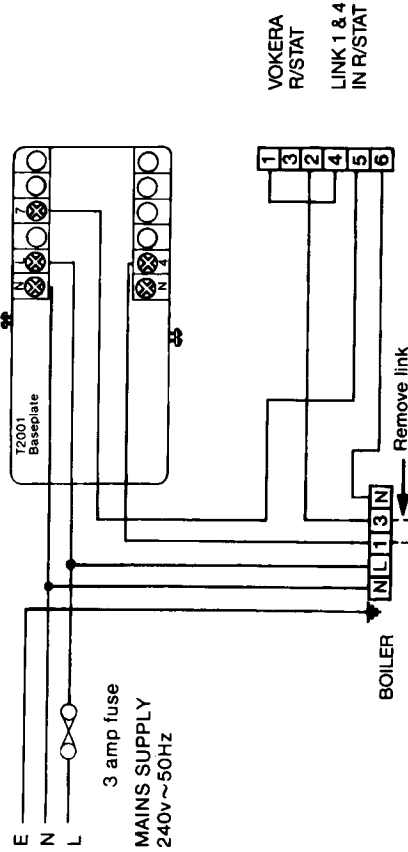

(iii) Randall Time Switch Vokera Room Thermostat

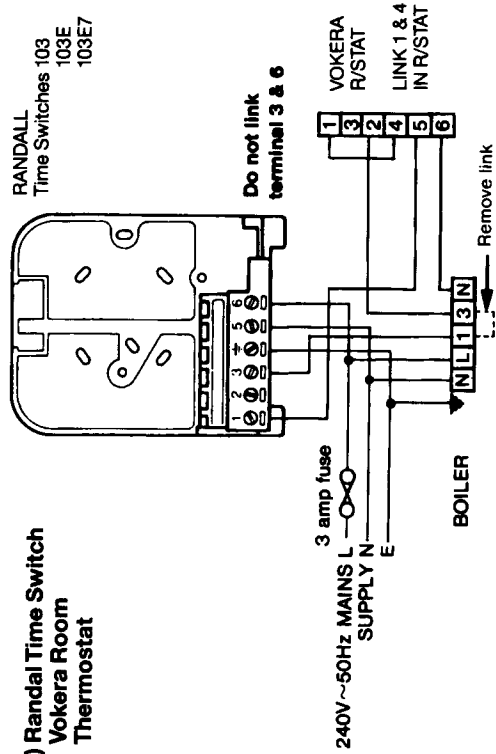

C. Wiring to 'Y' plan or 'S' plan installations

(i) 'Y' Plan

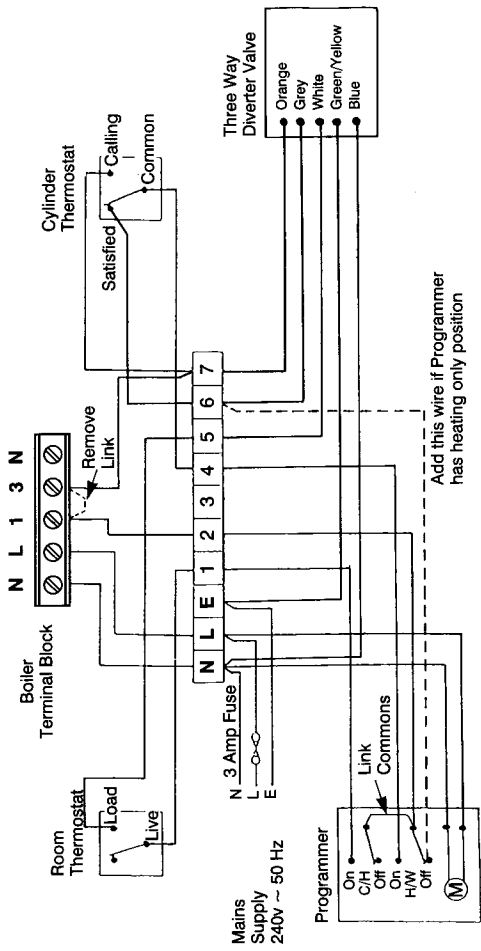

(ii) 'S' Plan

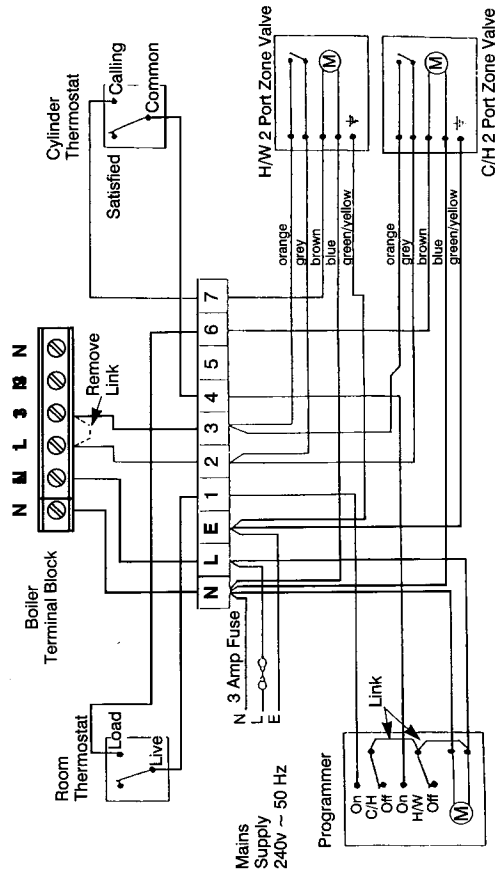

EXPLODED DIAGRAMS Fig. 42

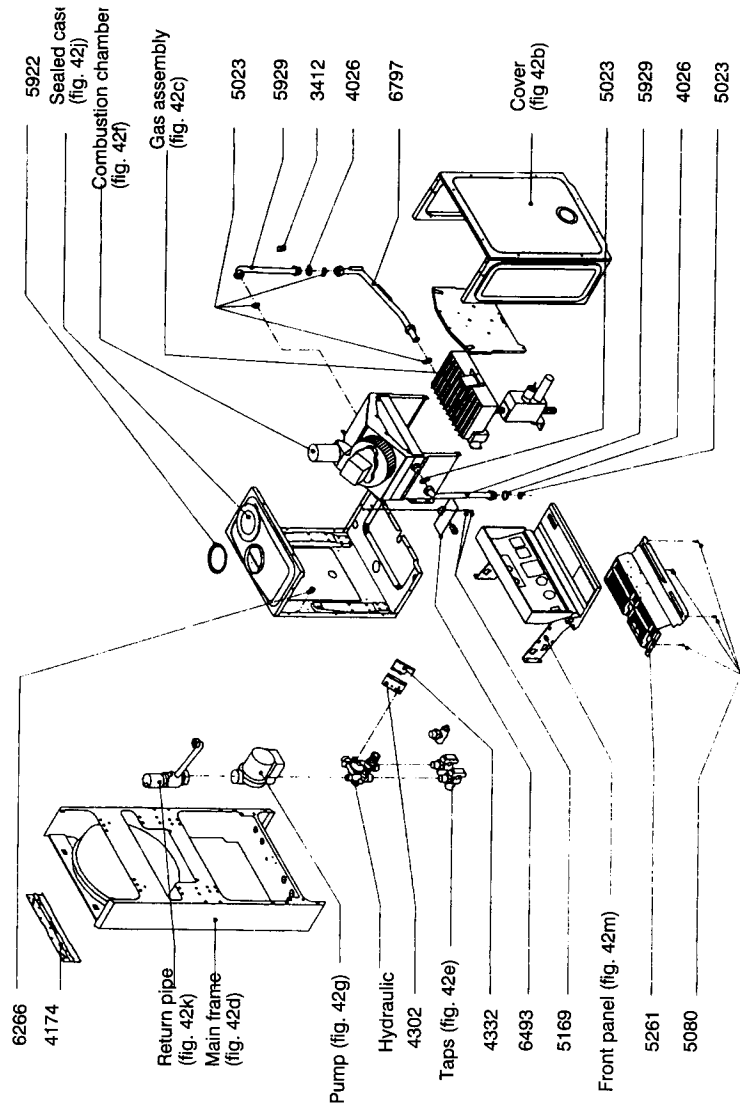

Fig. 42a Outer Casing

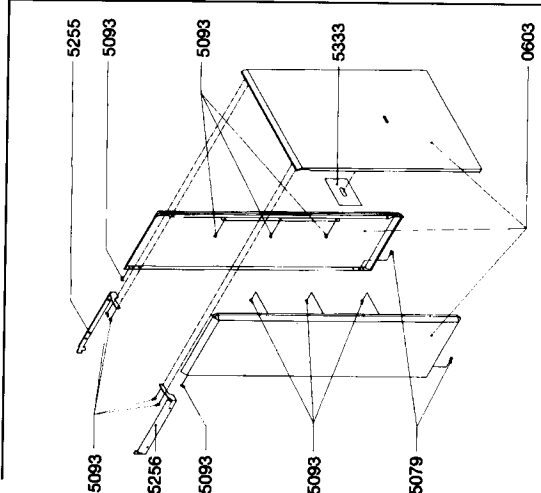

Fig. 42b Cover and Left-Right Sides

Fig. 42c Gas Assembly

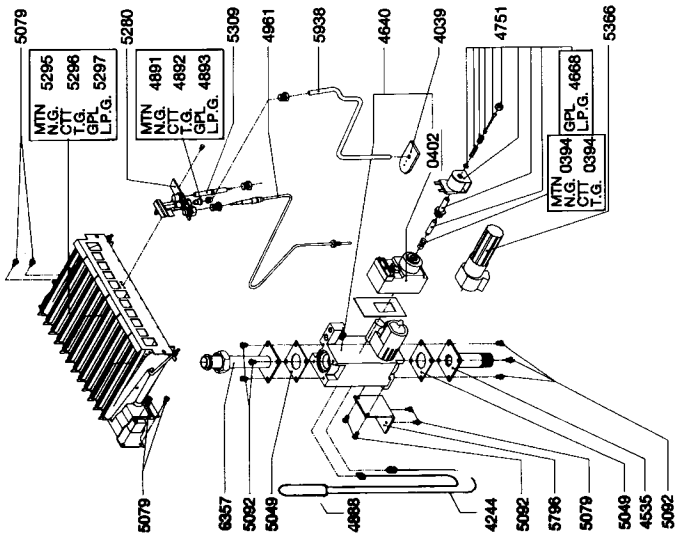

Fig. 42d Expansion Vessel 10 ft.

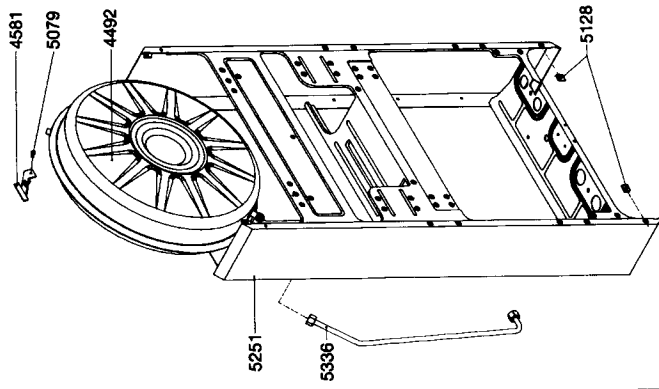

Fig. 42e Taps and Connection Pipes

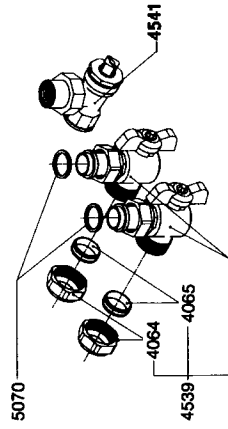

Fig. 42f Combustion Chamber

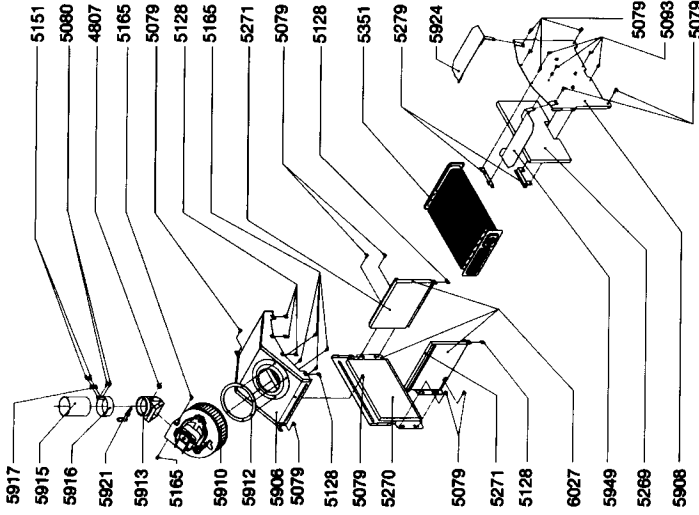

Fig. 42i 90° Bend

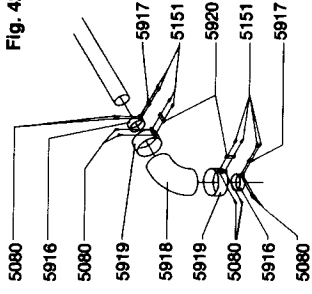

Fig. 42g
Circulation Pump 15-50

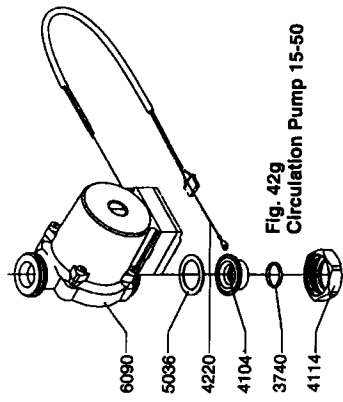
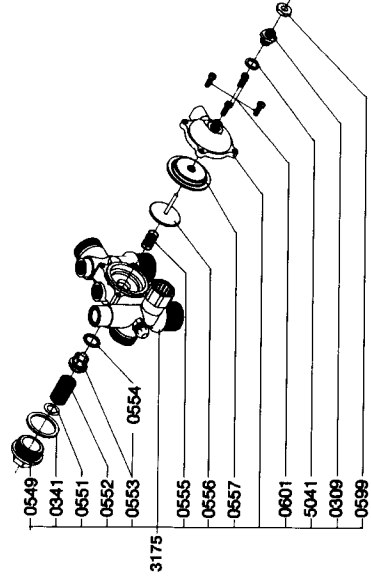

Fig. 42h Central Heating Manifold with Automatic By-Pass



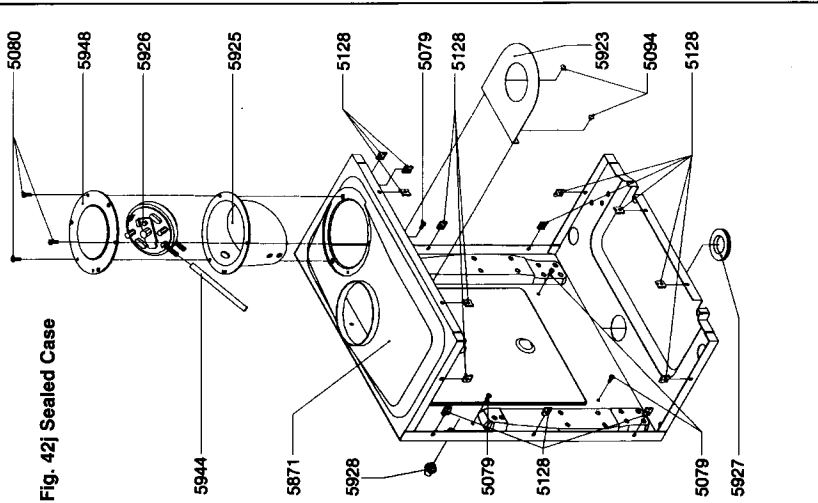

Fig. 42j Sealed Case

Fig. 42k Return pipe with air separator

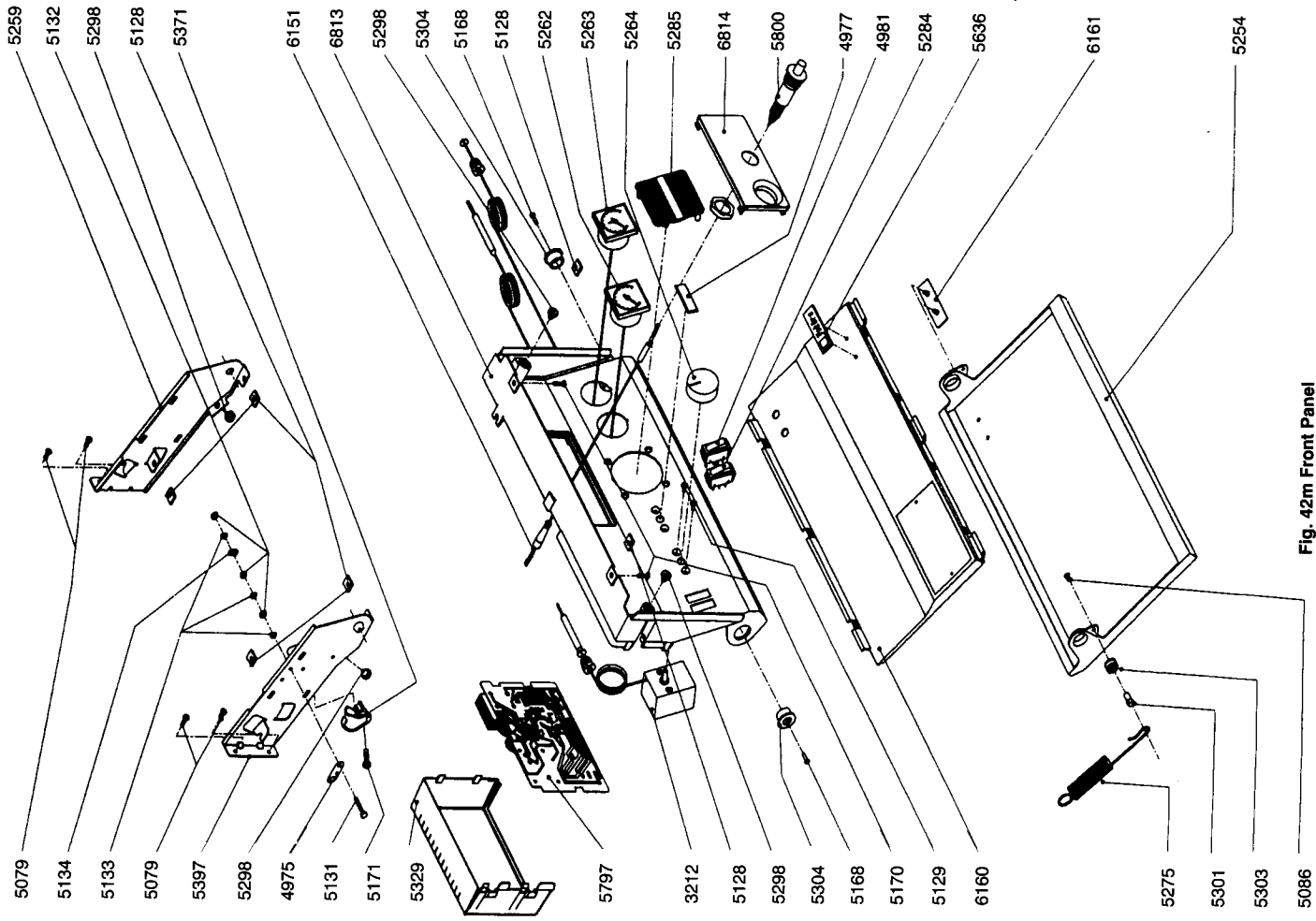
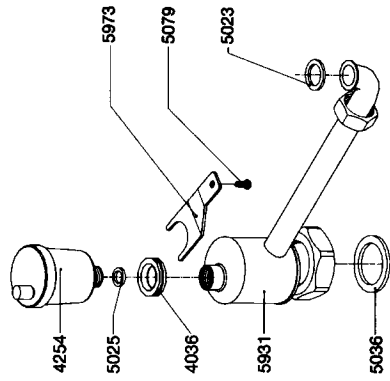
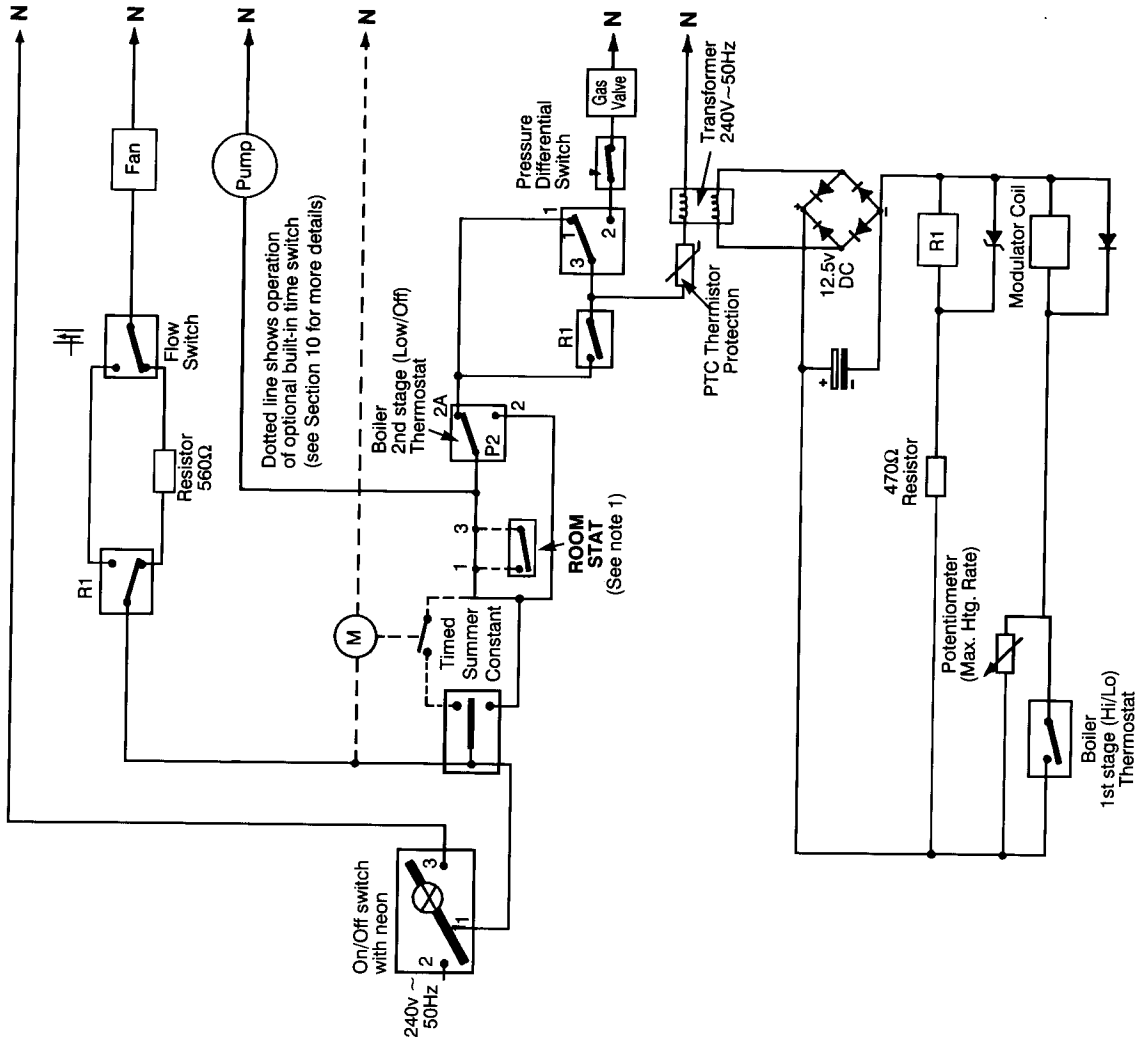

Fig. 42m Front Panel

Code	G.C. No.	Description
0402	333 837	Gas Valve Solenoid 220/240v
0557	333 941	Flow switch diaphragm
3175	370 307	Heating Manifold
3212	333 945	Boiler thermostat
4250	333 772	Safety valve
4254	333 722	Automatic Air Vent
4302	333 773	Single micro switch flow switch
4492	333 733	Expansion Vessel
4541	333 780	Gas Service tap
4640	333 888	Gas Valve complete 220/240v
4751	333 890	Modulator Coil Assembly
4888	333 894	High Limit Thermostat
4981	333 961	Timed/Rest/Constant Switch
5262	301 003	Temperature Gauge
5263	301 004	Pressure Gauge
5264	301 005	Thermostat knob
5284	301 009	On/Off switch
5295	301 081	Burner
5309	301 083	Spark electrode
5351	301 085	Main Heat Exchanger
5797	301 089	Printed Circuit
5800	301 090	Piezo Igniter
5910	394 754	Fan RL 97
5926	301 063	Pressure Differential switch
6090	384 288	Grundfos circulating pump UPS 15-50

FUNCTIONAL FLOW DIAGRAM General Layout



- Notes
1. If external controls are fitted link 1-3 removed
 2. Boiler 1st and 2nd Stage thermostats in common housing

Fig.43

GENERAL LAYOUT OF WIRING FROM PRINTED CIRCUIT BOARD

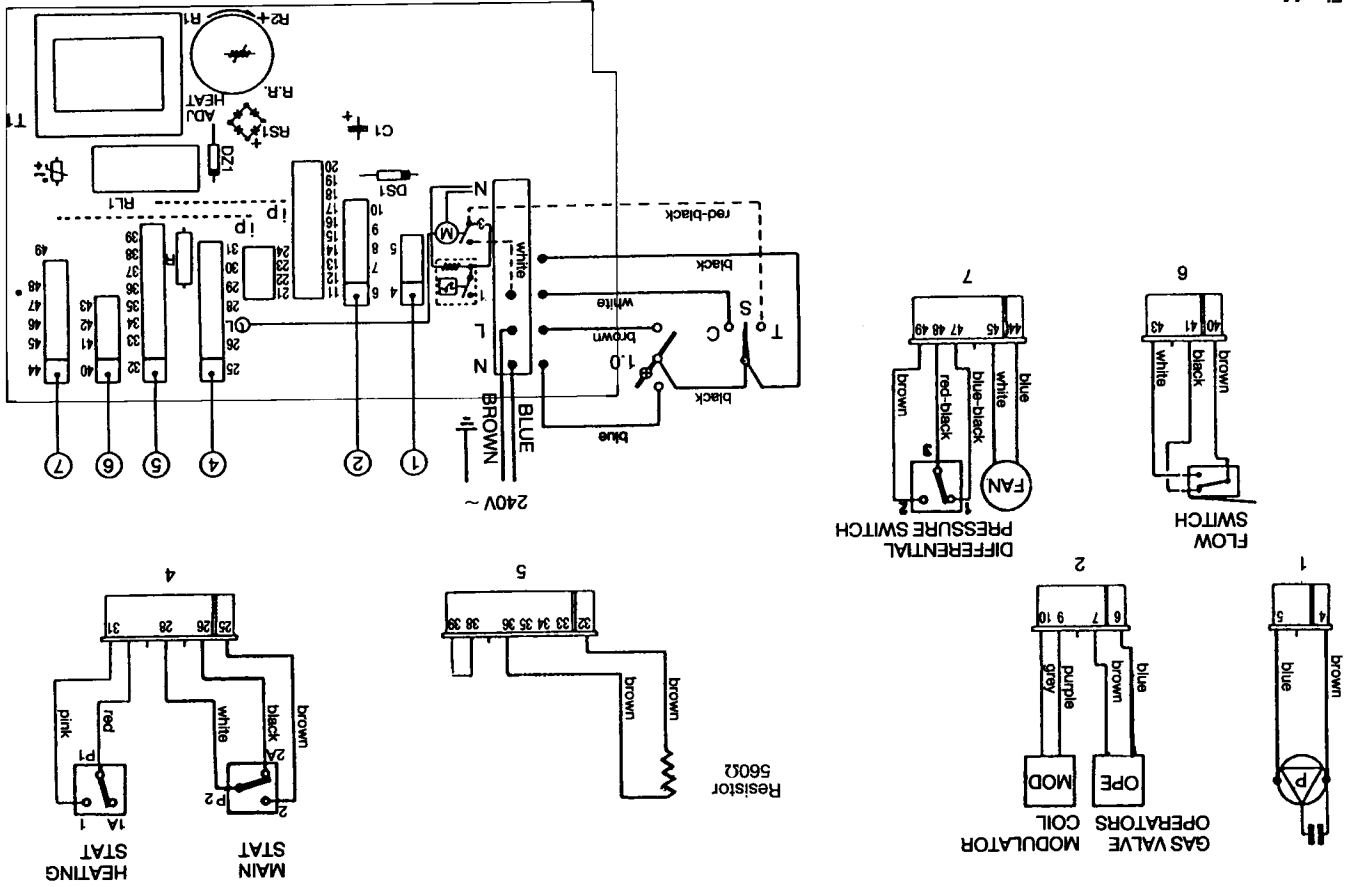

Fig. 44

ILLUSTRATED WIRING DIAGRAM

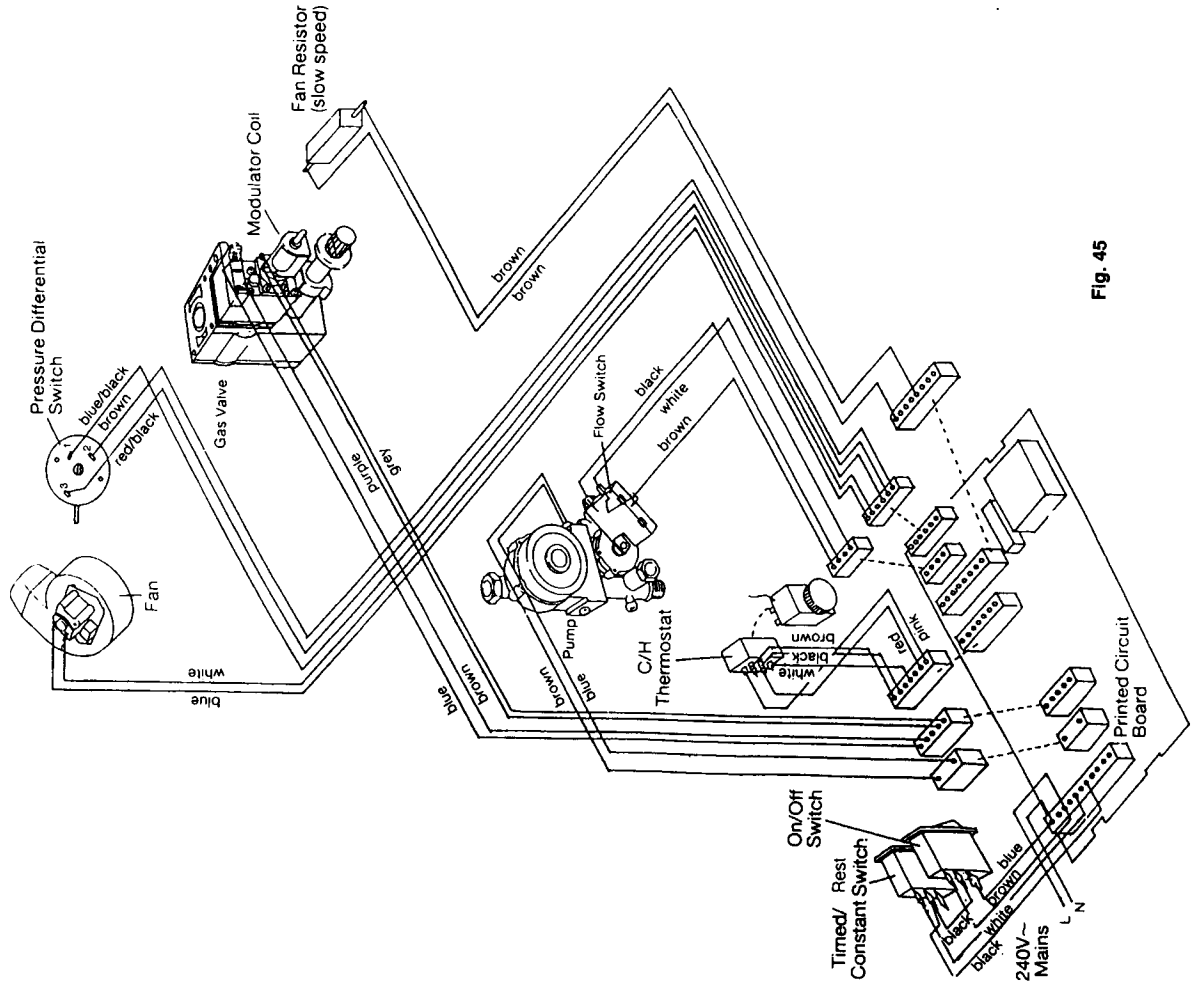

Fig. 45

1

1



G R Claudio Vokèra Limited
Head Office and Accounts: Unit 16, Duck Lees Lane, Enfield, Middlesex EN3 7SF. Tel: 081-804 7202. Fax: 081-804 8163
Northern Region: 360 Bowling Back Lane, Bradford, West Yorkshire BD4 8TS. Tel: 0274 660314. Fax: 0274 660446
Scottish Region: Shuna Street, Maryhill, Glasgow G20 9NW. Tel: 041-945 4944. Fax: 041-945 5136