



# Netaheat balanced flue gas-fired boilers

Potterton Netaheat MK.IIF 10–16  
10 to 16 kW (34,000 to 55,000 Btu/h) Output

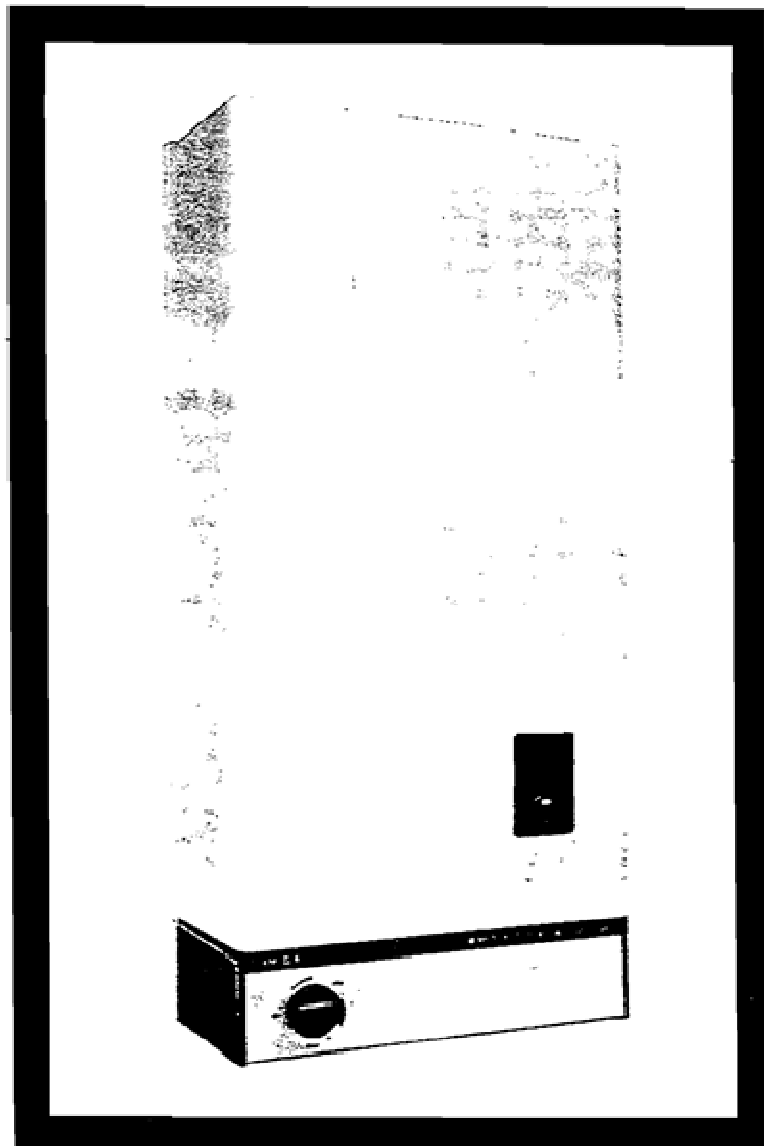
Fitted with Printed Circuit Control Panel

Potterton Netaheat MK.IIF 16–22  
16 to 22 kW (55,000 to 75,000 Btu/h) Output

Fitted with Printed Circuit Control Panel

**INSTALLATION INSTRUCTIONS  
WITH  
DATA INFORMATION**

These installation instructions are to be followed and the specification of the appliance must not be modified.



## GENERAL

Potterton Netaheat boilers are fully automatically controlled, wall mounted, balanced flue appliances, specially designed for combined gravity hot water and pumped central heating or fully pumped systems (small bore or micro-bore) giving ease of siting, installation and servicing.

## DESCRIPTION — See Fig. 1

Because of its slim dimensions and wall mounting characteristics, the Potterton Netaheat blends easily with other kitchen furniture and saves valuable floor space. It can be fitted on an outside wall, or on an internal wall as long as it is adjacent to any outside wall. The boiler can also be installed in cupboards or other confined spaces as long as these are suitably ventilated in accordance with British Standard Code of Practice 332, Part 2. All boiler components are secured to the casing back plate. A single piece cover which encloses the fan, heat exchanger and burner, seals the space inside from the room where the boiler is fitted. An easily removable drawer-shaped metal tray houses the boiler controls, but has the shaft for the thermostat knob protruding through it; this knob is the only user control. Side panels, to blank off the space between the wall and the back of the boiler, are available as optional extras. Also available as an optional extra is a casing extension which can be fitted on top of the existing boiler casing to enclose a circulating pump and its pipework.

## Heat Exchanger and Burner

The heat exchanger is a single "Monobloc" casting incorporating two finned flueways and three waterways, together with two flow connections, two return connections and a pocket for the thermostat phial. The capacity of the waterway is 5.7 litres (10 pints) and the resistance through the casting is such that gravity circulation at all ratings is possible on the domestic hot water circuit. The natural gas burner which is fitted immediately below the heat exchanger, has steel blades mounted on a fabricated manifold.

## Fan

The fan draws fresh air into the space formed by the boiler back plate and the removable cover. The air passes down the outside of the heat exchanger, so helping to cool the front cover, then into the combustion chamber. Combustion products pass up through the heat exchanger and into the fluehood where, because the fan has pressurised the inside of the appliance, they are forced out through the flue duct.

## Boiler Controls

The operation of the boiler is very simple with the user only having to turn the thermostat knob on or off as required. When the main inlet gas cock is turned on, gas

passes up to a solenoid valve inside the multi-functional control. The main electricity supply is then switched on and the thermostat turned on and to the required temperature. This turns on the fan which runs for a 10 to 15 second purge period before the pressure switch, sensing the fan running, closes. Once the pressure switch contacts have closed, the solenoid valve inside the multi-functional control opens, allowing gas to flow to the pilot burner. At the same time, the automatic electronic spark generator operates and the pilot is ignited. When the pilot has lit, the spark generator senses a change in resistance due to the presence of the pilot flame, and the spark is cut off, although the system is still energised so that if the flame should go out, the pilot would then automatically relight.

The pilot flame heats up the phial of the flame safety device and after about 40 seconds, the mercury in the phial vapourises and expands so operating a switch which opens a second solenoid valve in the multi-functional control, passing gas to the main burner.

The gas pressure to the main burner is controlled by an adjustable, spring loaded governor incorporated in the multi-functional control.

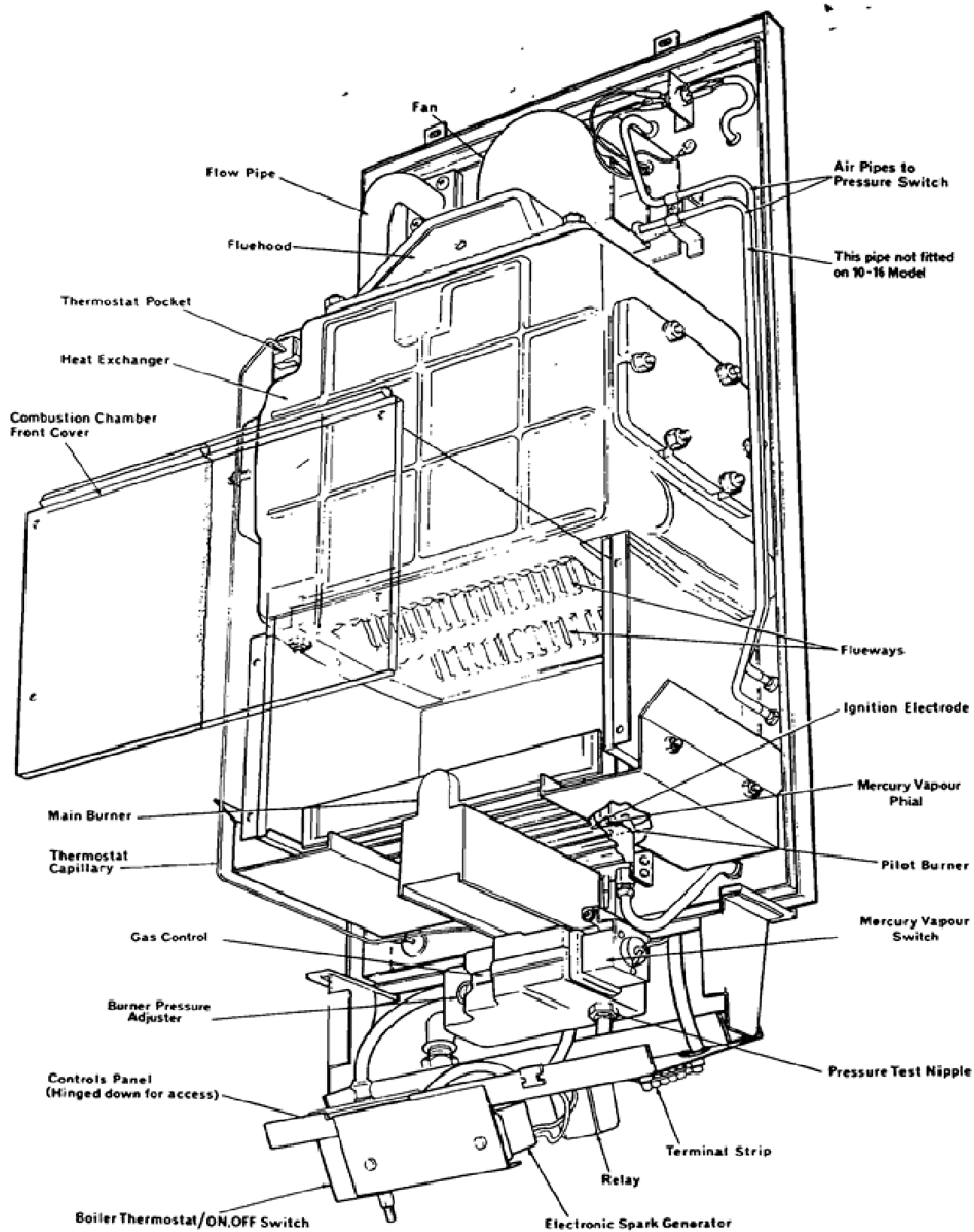
To turn the boiler off, the thermostat knob must be turned to the off position and the boiler will shut down. If there is a gas or electricity power cut at any time while the boiler is operating it will immediately shut down, but as soon as the power supply is restored, it will relight automatically.

The thermostat knob can be set to OFF, Min. 1, 2, 3, 4 and Max. The graduations Min. to Max. correspond approximately to a temperature range of 55°C–82°C (130°F–180°F). The 16–22 boiler has a pump over-run thermostat, used only when the boiler is installed in a fully pumped system and this will operate when the water temperature within the boiler is in excess of approximately 70°C (160°F). A drop of approximately 11°C (20°F) will occur before the thermostat will switch the pump off.

A wiring diagram, showing the boiler control system and printed circuit board distributor panel is given in Fig. 11.

## Balanced Flue Terminals and Ducting

The fresh air inlet and flue ducts can be run from either the left, right or rear of the boiler to a miniature terminal on the outside wall of the building. The ducts on the 10–16 model are suitable for any wall thicknesses up to 380mm (15in.) using a side outlet or 510mm (20in.) with a rear outlet. The ducts of the 16–22 model are suitable for wall thicknesses of up to 406mm (16in.), but for installations where a rear outlet is to be used, an extension sleeve which can be fitted between the two halves of the telescopic trunking, is available as an optional extra. With the sleeve fitted, wall thicknesses of up to 510mm (20in.) can be catered for. The siting of the balanced flue terminal on the outside wall of the building is not critical although if it discharges at a low level, a terminal guard, supplied as an optional extra, should be fitted in accordance with Building Regulations. The terminal should be installed in accordance with British Standard Code of Practice CP.337.



**Fig. 1 GENERAL ARRANGEMENT**

## THE SYSTEM

Potterton Netaheat boilers have been specially designed for combined systems e.g. small bore or micro-bore central heating with an indirect domestic hot water supply which can either have pumped or gravity circulation; the boiler can also be used for pumped central heating only. The boiler can be installed in most types of system, but the following notes are given as a general guide. Also refer to BS.5376 and BS.5449 Part 1.

All systems should be designed so that the static head of the boiler is between a minimum of 305mm (1ft.) and a maximum of 27.5m. (90 ft.). To ensure that the minimum 305mm (1ft.) static head is obtained, the level of the cold water in the expansion tank must not be lower than the top of the boiler casing.

If a minimum 305mm (1ft.) head is used, extra care should be taken when designing the system, to ensure that pumping over or sucking down at the vent pipe cannot occur.

All gravity domestic systems should have a minimum effective circulating head of 1.2m (4ft.).

A typical combined gravity system is shown in Fig. 12.

A fully pumped system giving temperature control of the central heating circuit via a room thermostat and one two-way valve is shown in Fig. 15.

Using the boiler as supplied, independent temperature control of the domestic hot water cylinder can only be applied when using fully pumped systems. If temperature control is required on a gravity hot water system, additional equipment is required and full details are shown in Fig. 13.

For independent temperature control of both the central heating and domestic hot water circuits, a three-way valve with a central position can be used. This type of valve can give a flow to either circuit separately or to both circuits simultaneously. For the wiring of this type of valve refer to the valve manufacturers literature and the information given in 6. Wiring.

Independent temperature control of both circuits can also be obtained by using room and cylinder thermostats and a two-position diverter valve. This valve provides a flow to one circuit at a time and details are shown in Fig. 14.

The use of two zone valves will also give independent temperature control of both circuits and full wiring details of this type of system are also given in Fig. 15.

A further method of providing independent temperature control in conjunction with room and cylinder thermostats, is by using two pumps. Details are given in Fig. 16. In addition to the system diagrams shown, full wiring details are also illustrated. It is recommended that when installing these systems, an indirect cylinder with a coil type of heat exchanger is used. When fitting the 16-22 boiler, no system should be designed in which it is possible to completely close both the domestic hot water and central heating circuits, and to obtain this, a by-pass should be fitted between the boiler flow and return pipework, capable of passing at least 1gall. per min. A by-pass is not required when installing the 10-16 boiler.

As the boilers are wall hung, a drain cock should be included at the lowest point in the central heating system. When selecting a circulating pump for the central heating system, the following data should be borne in mind:

### Circulating Pump Selection

The resistance through the heat exchanger is equal to 25mbar (10in.w.g.) at a flow rate of 27.25litres/min. (6galls/min.), when using the 1in. flow connection or 43.75mbar (17.5in.w.g.) at the same flow rate when using the 3/4in. flow connection, see Fig. 2. If other controls, such as three-way valves are used in this type of system, the resistance through them, quoted in their manufacturers literature, must be taken into account.

The circulating pump may be fitted on either the flow or return side of the boiler. If fitted on the flow, the central heating circuit will be under a positive pressure, so reducing the risk of air being drawn into the system, but if the pump is on the return there will be a negative pressure in the circuit; this applies with systems designed as illustrated in Figs. 12, 13, 14, 15 and 16. It is recommended that the static head on the inlet side of the pump should be at least a third of the maximum pump duty.

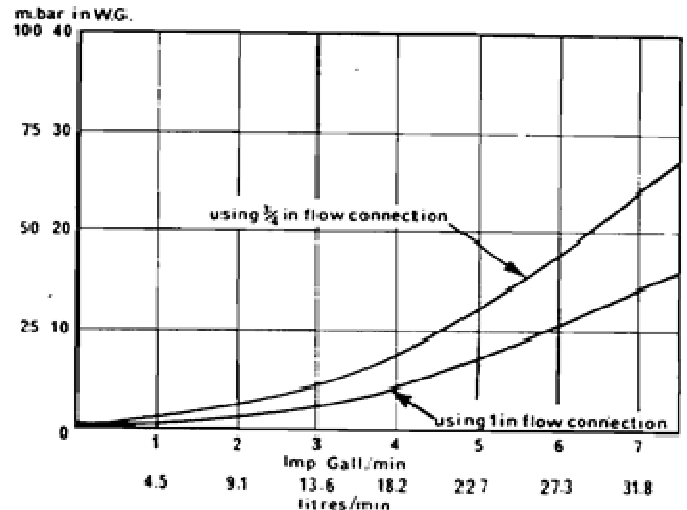


Fig. 2 PRESSURE LOSS ACROSS BOILER

## SITE REQUIREMENTS

Ensure that the gas supply pipe and meter are large enough for this appliance and any others that may be run off the same meter; if not, contact the local Gas Regional Office. The boiler can be installed at any height (refer to Clearances Around the Boiler and the static head requirements) on an outside wall or on an internal wall providing that one side of the boiler is next to an outside wall. The recommendations of the relevant British Standards Codes of Practice should be followed.

### Boiler Mounting Surface

The boiler must be mounted on a flat wall of non-combustible material sufficiently robust to take the weight of the boiler. The requirements of the local authorities and the Building Regulations must be adhered to.

### Clearances Around the Boiler — See Fig. 3

Any position selected for the boiler must give the following minimum clearances which are necessary for installation and maintenance.

- 910mm (3ft.) at the front of the boiler
- 100mm (4in.) at the top — except where the optional extra pump casing is to be fitted, when 178mm (7in.) must be allowed.
- 250mm (10in.) at the bottom

As all pipes can be run behind the boiler within the casing width, no clearance is needed at the sides.

### Ventilation

If the boiler is to be installed in a confined space such as a cupboard, the space will need ventilating. Openings should be provided at the top and bottom of the cupboard each of which should have a free area as follows:—

Potterton Netaheat	Free Area	
	Sq.in.	Sq.cm.
10-16	28	181
16-22	38	245

If the openings draw air from outside the building, the free areas may be halved. Refer to British Standard Code of Practice CP.332, Part 2 1968 for further guidance.

### Electricity Supply

A 240volts a.c. 50Hz. single phase electricity supply fused to 3 amps must be provided in accordance with the latest edition of the Institute of Electrical Engineers Regulations for the Electrical Equipment of Buildings and Local Authorities and British Gas requirements. The current rating of the wiring to the boiler must exceed 3 amps and must include an isolating switch or plug and socket; a double-pole switch is recommended.

### MAINTENANCE

The efficient performance of this boiler is dependent upon regular servicing which should be carried out annually.

Maintenance is best arranged by a contract placed with Potterton International Limited and further details are available from the local Potterton Regional Service Office.

All parts likely to require servicing are easily accessible. By sliding the cover from the boiler controls and removing the front cover from the boiler, most components are exposed. It is then a simple matter to remove the front of the combustion chamber to gain access to the main and pilot burners and the ignition electrode. Removal of the fluehood which is secured by four nuts, gives access to the flueways in the heat exchanger.

### SETTING UP

Each boiler has to be adjusted once it has been installed and this is a skilled job which should only be carried out by suitably qualified engineers. Potterton International offer this service at a nominal charge.

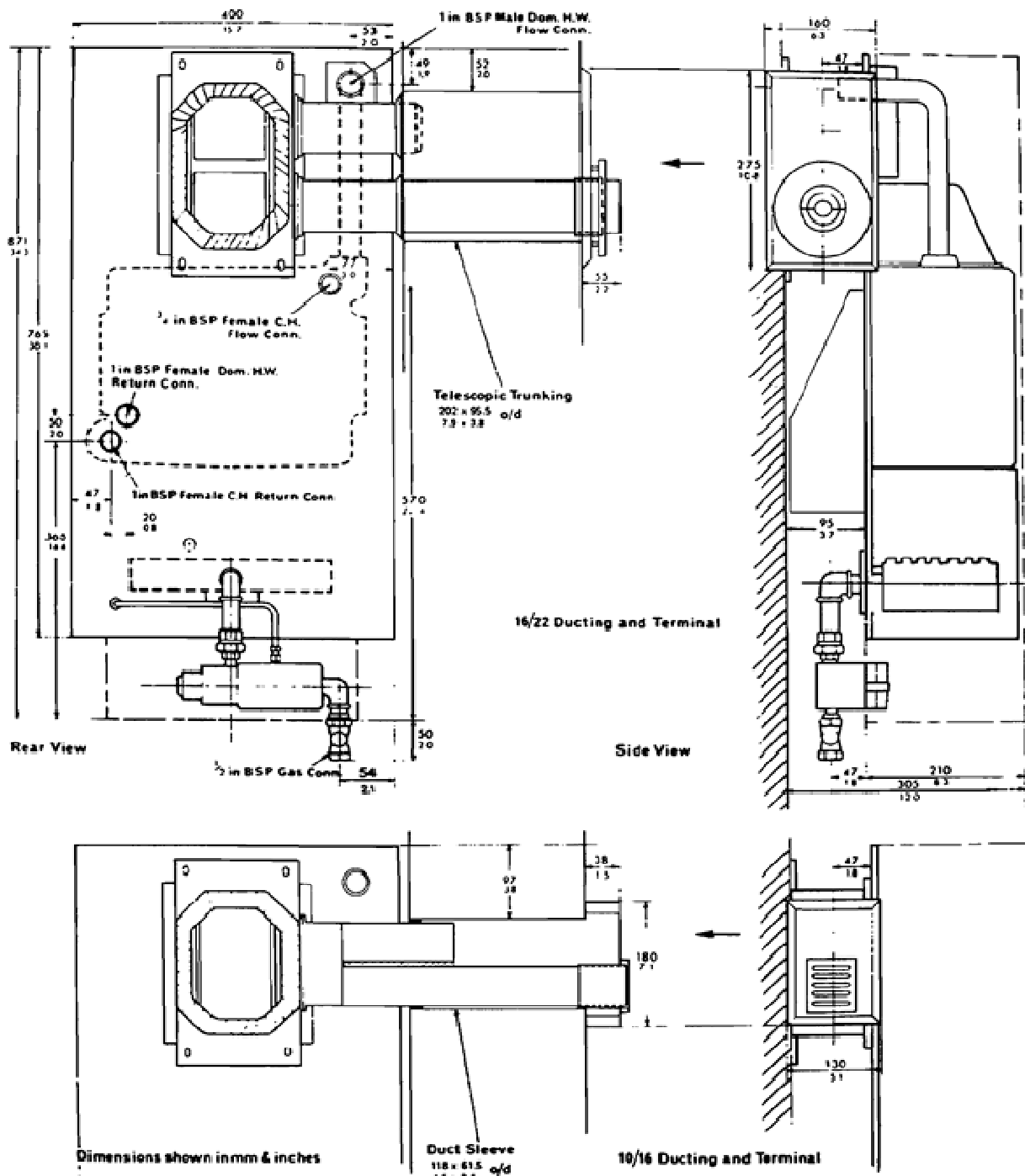


Fig.3 CONNECTIONS AND DIMENSIONS  
(See also Fig. 8)

## GENERAL DATA

Potterton Netaheat 10-16	Input: 13.4 to 20.9 kW (45,000 to 71,400 Btu/h)  Output: 10.0 to 16.1 kW (34,000 to 55,000 Btu/h)
Potterton Netaheat 16-22	Input: 22.5 to 29.6 kW (76,800 to 101,150 Btu/h)  Output: 16.1 to 22.0 kW (55,000 to 75,000 Btu/h)
Maximum Working Head:	27.5m (90ft.)
Weight:	Installed - 72.6 kg. (160lbs.) Installer lifting weight - 56.7 kg. (125lbs.)
Water Content:	5.7 litres (10pts.)

## CONTROLS

Main Gas Cock:	½in. BSP union Loose Key Cock.
Multi-functional Control:	White Rodgers, incorporating pressure governor, two solenoid valves and a pilot filter
Mercury Vapour Switch:	White Rodgers
Pressure Switch:	Honeywell, CN150B 100

Thermostat:	Ranco C26, 10-16 boiler Ranco C77, 16-22 boiler
Relay:	I.M.O. 3 pole relay
Fan:	Smiths FFB Q219 .
Pilot Burner:	White Rodgers
Main Burner:	Furigas
Ignition Electrode:	Royal Worcester
Spark Generator:	Plessey, 407/1/72637/010
Circuit Protector:	1 amp fuse. This rating must not be exceeded.
Distribution Panel:	P.C. Board including Mains Input Terminal.

## ADDITIONAL CONTROLS

Potterton Electronic Programmers are available as optional extras. These electronic programmers have been developed to compliment your boiler and offer the user a variety of programmes to suit individual requirements and systems. They are attractively styled with a constant digital clock display, slider and push buttons which are easy to use and understand. The Programmer is fully described in its own Data Sheet which is available on request.

## TECHNICAL LITERATURE

The following literature is supplied with each boiler:—  
Data and Installation Instructions.  
User's Guide.

# INSTALLATION INSTRUCTIONS

## 1. GENERAL

Installation must be carried out in accordance with the relevant British Standard Codes of Practice and I.E.E. recommendations. Reference should also be made to British Gas publication "Material and Installation Specifications for Domestic Central Heating and Hot Water".

The boiler and its associated equipment will arrive on site in two cardboard cartons. The contents of each carton is as follows, see Fig. 4.

### CARTON NO. 1:

1. Installation Instructions
2. Template
3. Accessories Card
4. Balanced flue terminal and ducts
5. Boiler Combustion chamber front cover
6. The controls cover
7. Mounting channel with rubber strip, and metal bearing plate and adjusting shims
8. Telescopic trunking - 16-22 only
9. Duct sleeve - 10-16 only
10. Duct sealing flange and gaskets - 16-22 only
11. The boiler front cover

### CARTON NO. 2:

The boiler packed on its back. The boiler will be supplied without its combustion chamber front cover fitted so giving a hand hold at the underside of the heat exchanger inside the combustion chamber, when lifting the boiler into position. Two metal feet will be found attached to the bottom of the boiler and these are to protect the controls during handling and also allow the appliance to be stood vertically prior to lifting it on to the wall.

All items in Carton No. 1 are packed so that they are easily removable in the sequence required.

## 2. FITTING THE BOILER MOUNTING CHANNEL

**NOTE:** The cardboard template has been designed for marking out the wall for boilers with either a rear or side flue outlet. If a side outlet is to be marked, it has been assumed that the boiler will be fitted tightly into the corner. However, allowance should be made if the corners of the wall are not square or

vertical, by positioning the template and therefore the boiler, up to a maximum of 1 in. from the outside wall. This can be done by marking the centre of the boiler position on the wall, then using a spirit level or plumb line, dropping a long centre line which can then be lined up with the boiler centre line marked on the template.

- A. Using the template, mark out the three screw holes on the wall where the boiler mounting channel is to be positioned, the four screw holes above the mounting channel where the plenum chamber is to be fitted, and the position of the flue and fresh air ducts on the wall.
- B. Drill the three holes for the mounting channel securing screws and insert wallplugs (Accessories Card Item A); fit and secure the channel using the 2in No.12 counter-sunk headed woodscrews, cup and flat washers; check that the channel is level. Place three of the six metal adjusting shims in the mounting channel followed by the rubber strip, then the metal bearing plate. Retain the remaining three shims.  
**NOTE:** The thickness of the wall plaster in some properties could be excessive and in these instances, it is recommended that 2½in. long securing screws are used in operation B.
- C. Drill the four holes for the plenum chamber securing screws and insert wallplugs (Accessories Card Item B); do not fit the plenum chamber at this stage.
- D. Cut the hole in the wall for the flue and fresh air ducts. Care should be taken when cutting the hole for a rear outlet boiler, that the screw holes for the plenum chamber are not damaged. Make good the inside and outside surface of the wall, if necessary, and also ensure that the face of the wall where the plenum chamber is to be fitted is flat.
- E. Open Carton No. 2.
- F. Unscrew and remove the nuts securing the fluehood, then lift off the fluehood, see Fig. 9. Discard the paper gasket.

- G. Disconnect the three electrical leads from the fan, then unscrew and remove the bolts securing the fan. Lift off the fan, see Fig. 9.
- H. Unscrew and remove the bolts securing the plenum chamber, see Fig. 9.
- J. Remove the boiler from its carton and lay it front face downwards on a protective surface, such as its own carton. Take care not to damage the shaft of the thermostat.

NOTE: A serrated washer is fitted beneath the centre bolt, number 4, which must be refitted when the boiler is secured to the wall.

### FITTING THE DUCTING, PLENUM CHAMBER AND BALANCED FLUE TERMINAL

#### A. Potterton Netaheat 10-16 only — See Fig. 5

- (1) Fit and cut the wall liner to size, terminating it flush with the inside and outside wall faces of the building. Ensure the ends are square.
- (2) The plenum chamber has two connections for the fresh air and flue ducts, one to one side and

the other to the rear. One of these connections is blanked off with a sealing plate and gasket and depending on the direction the ducts are to be connected to the boiler, these should be re-positioned by the installer if necessary. The single side connection can be used either for a left or right hand duct arrangement, simply by rotating the plenum chamber to the required position. With a rear outlet, the smaller opening in the plenum chamber, the air duct, must be positioned uppermost.

- (3) Fit the inlet and outlet duct assembly to the plenum chamber using the six screws (Accessories Card Item C) and interposing the gasket. Ensure that the short air inlet duct is fitted uppermost.
- (4) Temporarily secure the plenum chamber to the wall using the four 2in. No.12 counter-sunk headed screws, cup and flat washers (Accessories Card Item B), positioning the flue and fresh air ducts inside the wall liner.

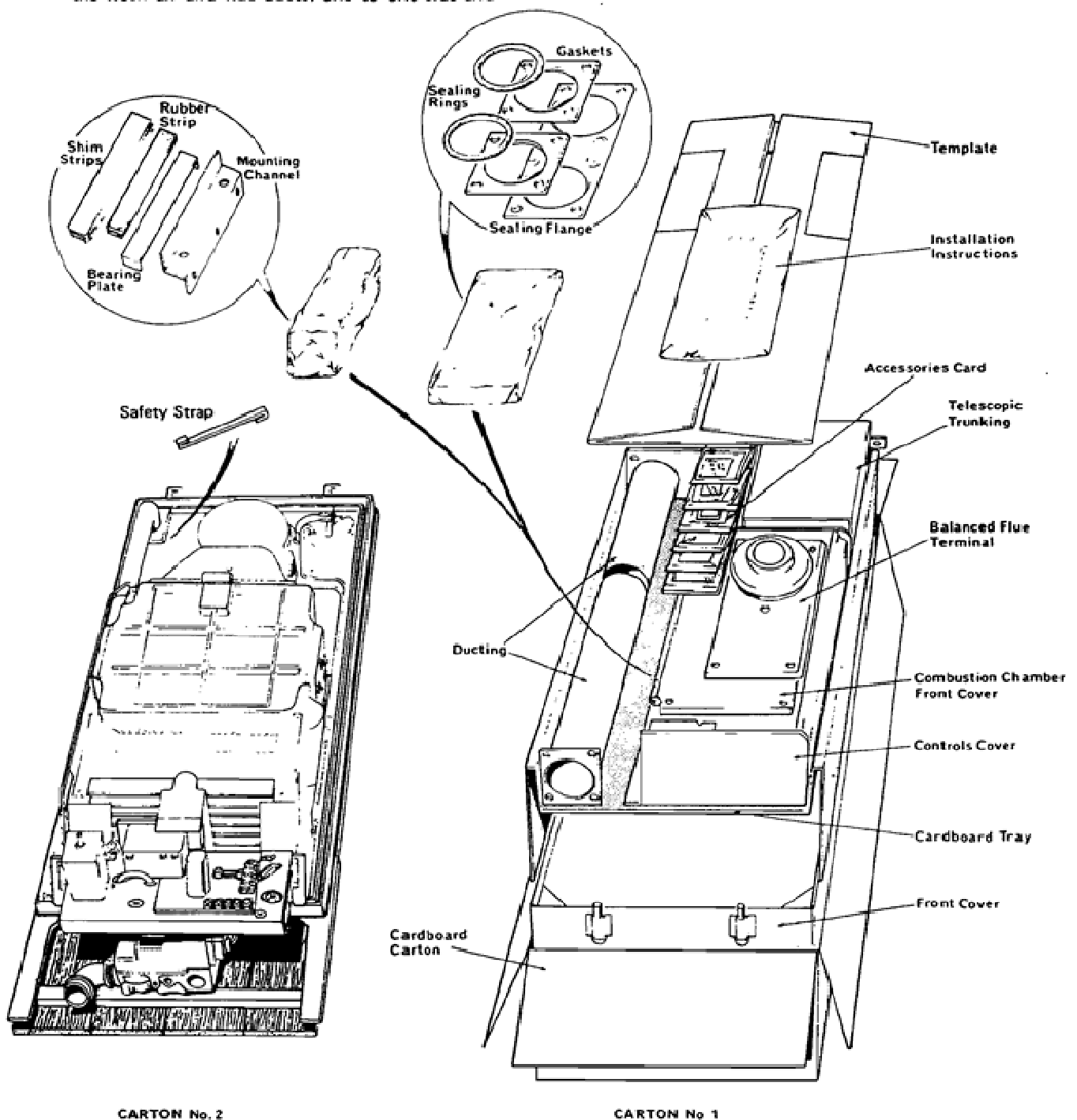


Fig. 4 PACKAGING AND IDENTIFICATION OF COMPONENTS

(5) Mark off the lower flue duct at a point where it protrudes 41mm (1.6in.) from the outside wall of the building. This dimension is important. Mark off both ducts at a point where they enter the wall liner.

(6) Remove the plenum chamber and liner from the wall, then cut the flue duct to size, removing all burrs.

NOTE: The upper air duct is already sized to suit wall thicknesses down to 205mm (8in.). It will only need shortening if the wall thickness is less than this in which case, cut it so that at least 25mm (1in.) protrudes inside the wall.

(7) On boilers using a side outlet only, position the duct assembly inside the liner, aligning the mark on the ducts with the entrance of the liner. Flatten the 13mm glass fibre rope seal, then force it into the gap between the ducts and the liner.

WARNING : IT IS VITAL THAT A GOOD SEAL IS MADE ALL AROUND BOTH DUCTS.

(8) On boilers using a rear outlet only, position the wall liner inside the wall separately as in this instance, the 13mm glass fibre rope seal is not required. The rope on the rear of the plenum chamber provides the necessary seal.

(9) Position the ducts and liner assembly inside the wall, then secure the plenum chamber to the wall with four 2in. No.12 screws, cup and flat washers

(Accessories Card Item B). Ensure the chamber is mounted squarely.

NOTE: The thickness of the wall plaster in some older properties could be excessive and in these instances, it is recommended that 2½in. long screws are used.

(10) Measure the distance from the bottom of the plenum chamber wall plate to the top of the metal bearing plate in the boiler mounting channel, see Fig. 6. Compare this dimension with the nominal dimension of 257mm and by adding additional shims or removing those already in position, adjust the measured distance to equal the nominal measurement, ± 1.5mm (1/16in). If a more coarse adjustment is necessary, the plenum chamber and mounting channel can be moved slightly up or down on the wall using the elongated holes in their mounting flanges. It is essential that this dimension is accurately obtained, otherwise once the boiler is lifted onto its mounting channel, the screw holes in the boiler back plate will not align with those in the plenum chamber.

(11) Make good the inside and outside wall surfaces around the liner as necessary.

(12) Fit the balanced flue terminal over the end of the flue duct, ensuring that the duct is located inside the outlet aperture on the terminal. Secure the terminal to the wall with the two size 8, 1in. long screws supplied (Accessories Card Item E).

NOTE: When fitting the terminal, observe the "Top" mark on the terminal.

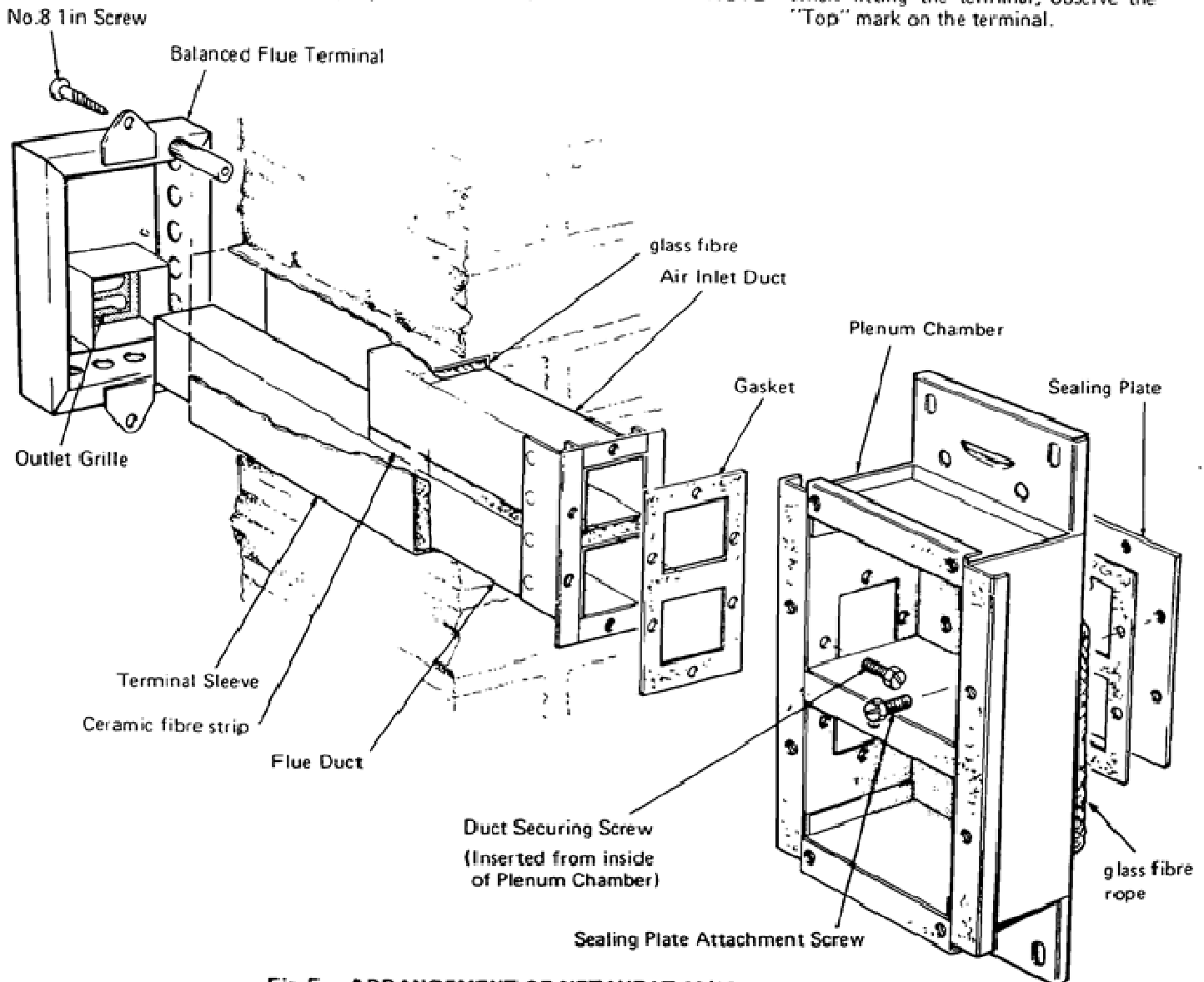


Fig. 5 ARRANGEMENT OF NETAHEAT 10/16 DUCTS



- (13) Remove the flue outlet grille from the terminal, then seal the gap between the outlet duct and the terminal with the sealing strip supplied.
- (14) Refit the outlet grille to the terminal so that it will direct the flue gasses sideways or downwards away from any obstruction, window, doorway, footpath or plastic pipe.

**B. Potterton Netaheat 16-22 only – See Fig. 7**

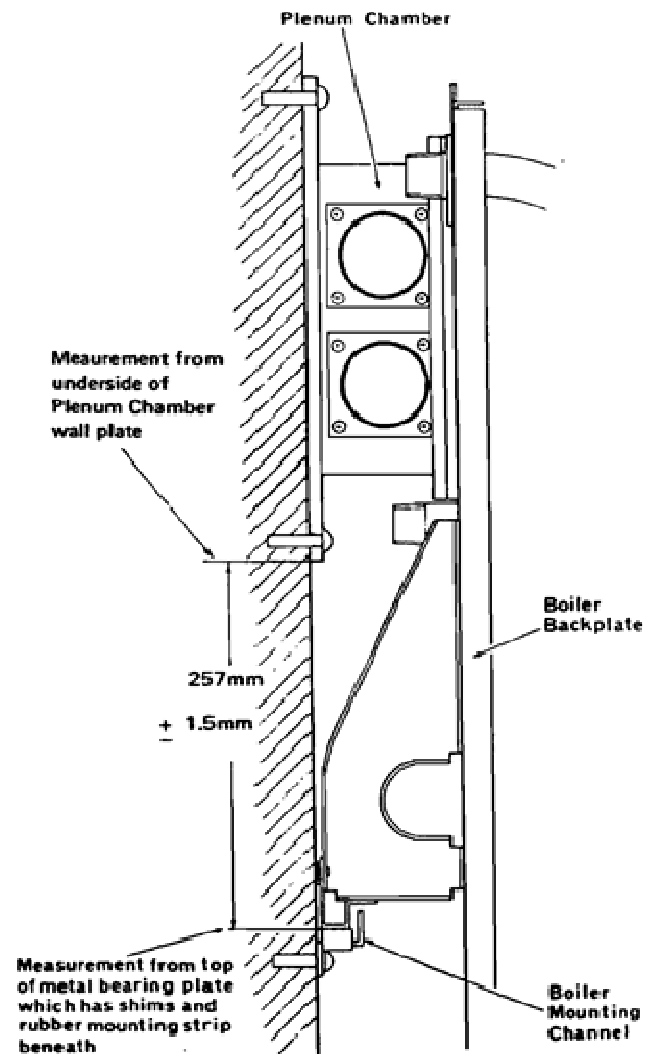
- (1) The plenum chamber has two connections for the fresh air and flue ducts, one to one side and the other to the rear. One of these connections is blanked off with two sealing plates and gaskets and depending on the direction the ducts are to be connected to the boiler, these should be re-positioned by the installer if necessary. The single side connection can be used either for a left or right-hand duct arrangement, simply by rotating the plenum chamber to the required position. With a rear outlet, the smaller opening in the plenum chamber (air duct) must be positioned uppermost.
- (2) Fit the inlet and outlet duct assembly to the plenum chamber using the eight screws (Accessories Card Item C) and interposing the two gaskets. Ensure that the short air duct is positioned uppermost.
- (3) Temporarily secure the plenum chamber to the wall using the four 2in. No.12 screws, cup and flat washers (Accessories Card Item B), positioning the flue and fresh air ducts through the wall.
- (4) Mark off the lower flue duct at a point where it protrudes 32mm (1.3in.) from the outside wall of the building.
- (5) The upper air duct is already sized to suit wall thicknesses between 230mm and 380mm (9 to 15in.) and will only need shortening, if the wall is less than 230mm (9in.) thick. In this instance, cut off the nozzle end of the upper duct so that not less than 25mm (1in.) and not more than 50mm (2in.) protrudes inside the wall.
- (6) Remove the plenum chamber, then cut the duct(s) to size, removing all burrs and taking care not to distort the circularity of the duct(s).
- (7) Fit the telescopic trunking inside the wall and secure it to the inside face of the wall with two 1½in. No.8 screws, washers and wallplugs (Accessories Card Item D).
 

**NOTE:** If the wall is less than 230mm (9in.) thick both halves of the telescopic trunking will have to be cut to the size at the plain ends where the two halves slide together; e.g. for a 180mm (7in.) wall, cut 50mm (2in.) from each half.
- (8) On boilers with a side flue outlet, slide the duct sealing flange and sealing rings onto the ducts. On boilers with a rear flue outlet, the flange and sealing rings are not required and should be discarded.
- (9) Position the ducts inside the wall, then secure the plenum chamber to the wall with four 2in. No.12 screws, cup and flat washers (Accessories Card Item B). Ensure the chamber is mounted squarely.
 

**NOTE:** The thickness of the wall plaster in some older properties could be excessive and in these instances, it is recommended that 2½in. long securing screws are used.
- (10) Secure the duct sealing flange and sealing rings, if applicable, to the telescopic trunking using the four screws (Accessories Card Item D).
- (11) Measure the distance from the bottom of the plenum chamber wall plate to the top of the metal bearing plate in the boiler mounting

channel, see Fig. 6. Compare this dimension with the nominal dimension of 257mm (10 1/8in) and by adding additional shims or removing those already in position, adjust the measured distance to equal the nominal measurement, + 1.5mm (1/16.). If a more coarse adjustment is necessary, the plenum chamber and mounting channel can be moved slightly up or down on the wall using the elongated holes in their mounting flanges. It is essential that this dimension is accurately obtained otherwise once the boiler is lifted onto its mounting channel, the screw holes in the boiler back-plate will not align with those in the plenum chamber.

- (12) Make good the inside and outside surface of the wall around the telescopic trunking. Ensure that the flue outlet duct protrudes from the trunking in the CENTRE of the square aperture. This is essential to enable the next operation to be completed.
- (13) Fit the terminal outer wall plate in position, locating the end of the exhaust duct inside the circular connection of the wall plate grille. Loosely attach the plate to the trunking with the single M5 screw (Accessories Card Item E).
- (14) Square up the wall plate, then working through the four screw holes in the plate, mark the screw hole positions on the wall behind the plate.
- (15) Remove the wall plate, then drill and plug the four holes with wallplugs (Accessories Card Item E).



**Fig. 6 RELATIVE POSITION OF PLENUM CHAMBER AND MOUNTING CHANNEL**

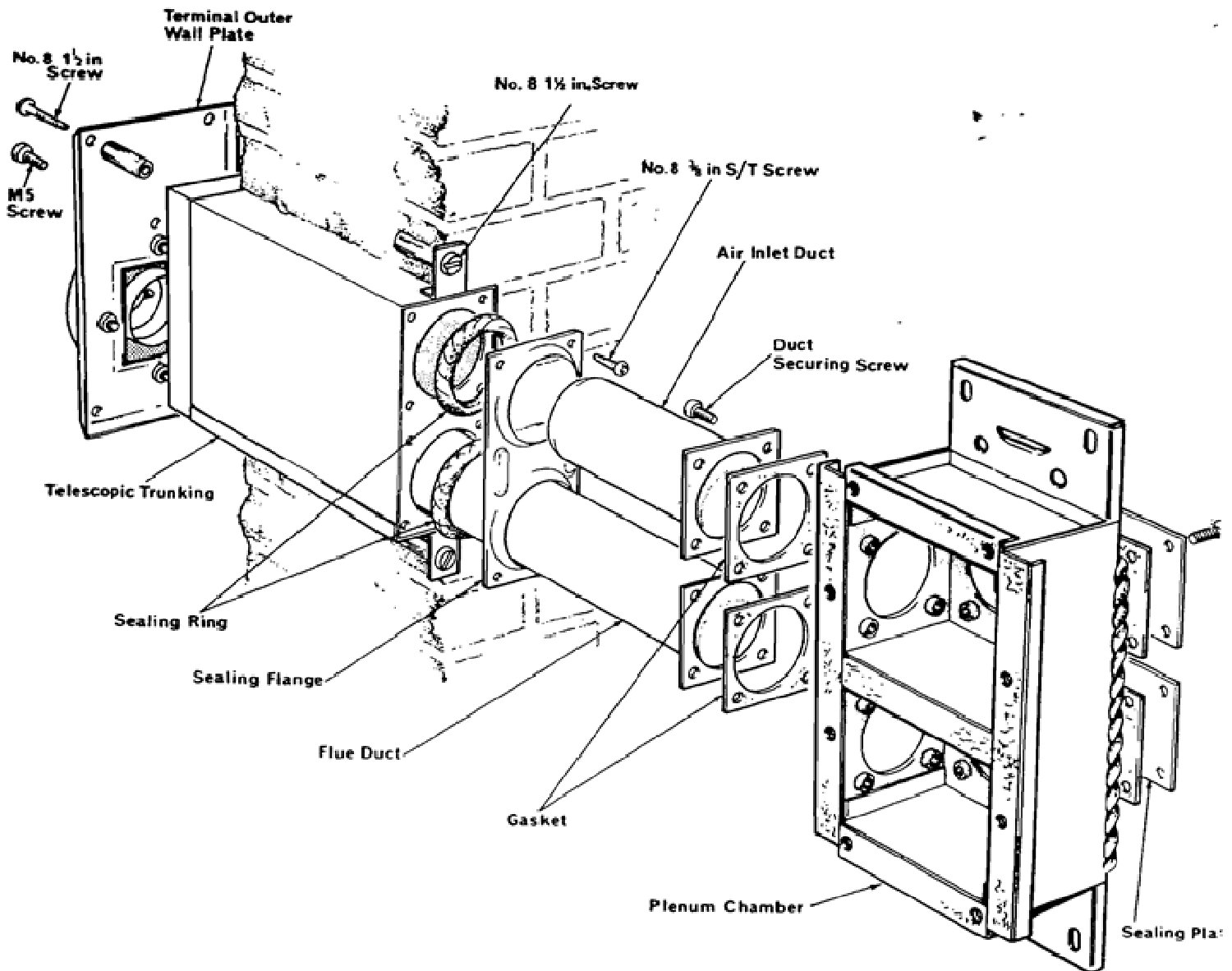


Fig. 7 ARRANGEMENT OF NETAHEAT 16/22 DUCTS

- (16) Refit the wall plate, then secure it to the trunking with the single screw and to the wall with four No.8, 1 in. long screws (Accessories Card Item E). It is essential for the correction operation of the unit, that no gap exists between the wall plate and the trunking.

#### 4. PREPARING THE BOILER

The boiler is designed so that all pipes can be hidden within its own width except where they leave the boiler at top and/or bottom. Because the water connections are behind the boiler backplate, short lengths of pipe will have to be connected to some of the tapplings to be used before the boiler is lifted into position, and terminated in a position suitable for connecting to the system pipework; it is recommended that copper capillary connections are used. Although it is possible to install the boiler and its pipework with only access from the front, it is very much easier with access from at least one side. This access is not necessary for maintenance which can be carried out from the front only. Pipe runs must be kept clear of the areas where the plenum chamber is to be fitted and where the air inlet and flue ducts will be located if a side outlet is being used. Connections which can be used and suggested methods of running pipework behind the boiler are shown in Fig. 8. Any pipe tails running downwards from behind the boiler should not protrude below the bottom of the metal feet. Refer to Figs. 12 to 16 for diagrams of typical systems to which the boiler can be connected.

#### A. Combined Gravity System

- (1) Using Fig. 8 as a guide, decide on the best pipe run at the rear of the boiler to suit the particular system.
- (2) Connect a suitable length of 28mm pipe to the domestic hot water flow connection.
- (3) Connect a suitable length of 22mm pipe to the heating flow connection. There is space behind the boiler to split the flow if necessary. The central heating circulating pump can be fitted above or below the boiler on either the flow or return as required.
- (4) Connect a suitable length of 28mm pipe to the upper 1 in. domestic hot water return connection.
- (5) Connect a suitable length of 22mm pipe to the lower 1 in. central heating return connection. There is space behind the boiler to combine the two heating circuits if required.

NOTE: Ensure that the fittings to the two return connections do not protrude more than 97mm from the boiler backplate or they may foul the wall.

#### B. Fully Pumped System and Central Heating Only

- (1) Using Fig. 8 as a guide, decide on the best pipe run at the rear of the boiler to suit the particular system.

- (2) When connecting the flow pipework, it is only necessary to use one flow connection, preferably the upper 1 in. BSP with the lower 3/4 in. connection being blanked off. However, in certain circumstances where a left-hand flue terminal is being used and only a pipe run to low level is required, the lower 3/4 in. BSP connection can be utilised, provided the 1 in. connection is vented. Connect a suitable length of pipe to whichever connection is to be used.
  - (3) Connect a suitable length of 22mm pipe to the lower 1 in. return connection. The upper 1 in. return can either be blanked off or used to connect the cold feed.
- NOTE: On systems requiring a high flow rate, the 22mm (3/4 in.) pipework from the flow and return connections should be enlarged as close to the boiler as practicable.
- (4) The circulating pump can be fitted on either the return or flow in any position to suit the particular installation.

### C. Boiler Main Gas Cock

- (1) The main gas cock is supplied loose but tied to the boiler and must be fitted directly to the union nut and liner already fitted to the inlet elbow. The tap must then be located in the most suitable position for operation.
- NOTE: In some installations where there is a minimum clearance beneath the boiler, it may be advisable to turn the inlet elbow to the horizontal to enable the connection to be made to the cock.
- (2) Connect a suitable length of 15mm pipe to the main gas cock, terminating it above, below or to the side of the boiler in a length which can be easily connected to the main supply, once the boiler is in position on the wall.

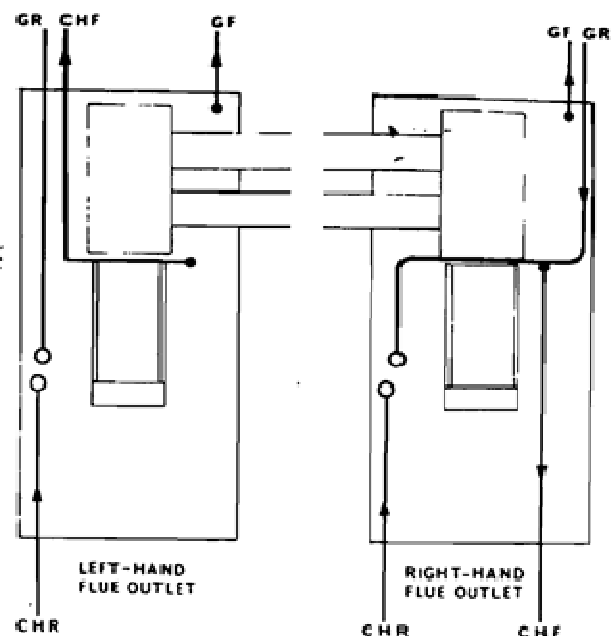
### 5. FITTING THE BOILER ON THE WALL – See Fig. 9

A metal safety strap is provided with this boiler which is used to hold the boiler backplate against the plenum chamber once the boiler has been lifted into position but before any plenum chamber securing bolts have been fitted.

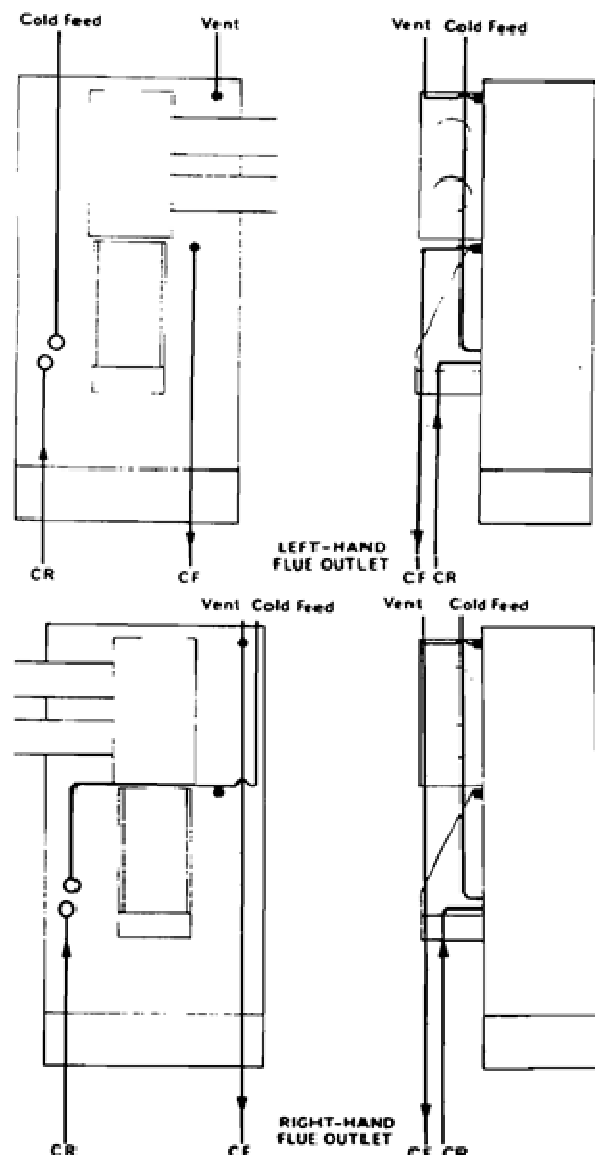
This will enable the installer to leave the boiler unattended once it has been positioned, so enabling him to pick up a screwdriver etc.

The strap must first be positioned by hooking its free ends behind the upper plenum chamber securing bracket, immediately above the two upper securing screws. It can then be hinged upwards against the wall until the boiler has been fitted when it can be hinged downwards, so holding the backplate against the plenum chamber.

- A. Stand the boiler on the floor in a vertical position, then using the two metal feet, the cast iron flow pipe and the underside of the heat exchanger, lift the boiler into position on the wall, locating its mounting bracket on the bearing plate in the mounting channel. Support the boiler in this position, using the safety strap if necessary, then secure the boiler backplate to the plenum chamber with seven bolts, see bolts numbered 1 to 7 on Fig. 9. Ensure that the serrated washer is fitted beneath the centre bolt, number 4. Three bolt holes in the boiler backplate are marked with a ring and these are for use when fitting the fan and must not be used in this operation.



SYSTEMS USING GRAVITY H.W.



FULLY PUMPED SYSTEMS

#### LEGEND

CHR	Central heating return	GF	Gravity flow
CF	Combined flow	GR	Gravity return
CR	Combined return	CHF	Central heating flow

Fig. 8 SUGGESTED PIPEWORK VIEWED FROM BEHIND BOILER

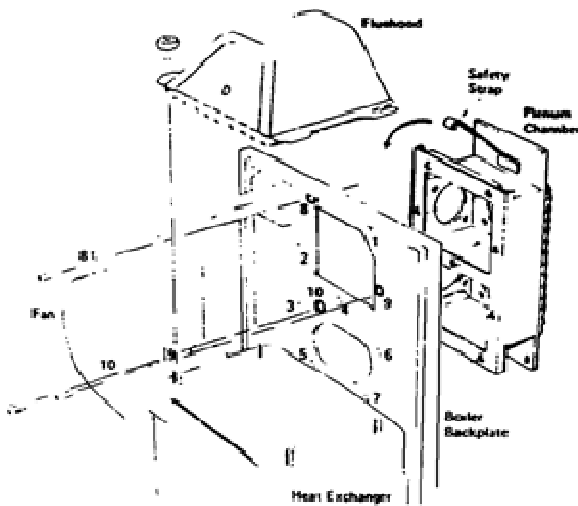


Fig. 9 PLENUM CHAMBER, FLUEHOOD AND FAN ATTACHING PARTS

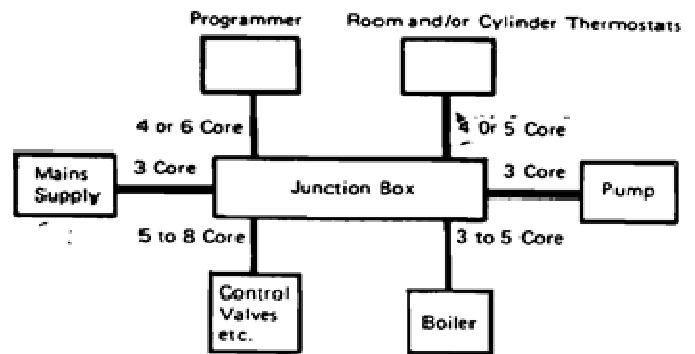
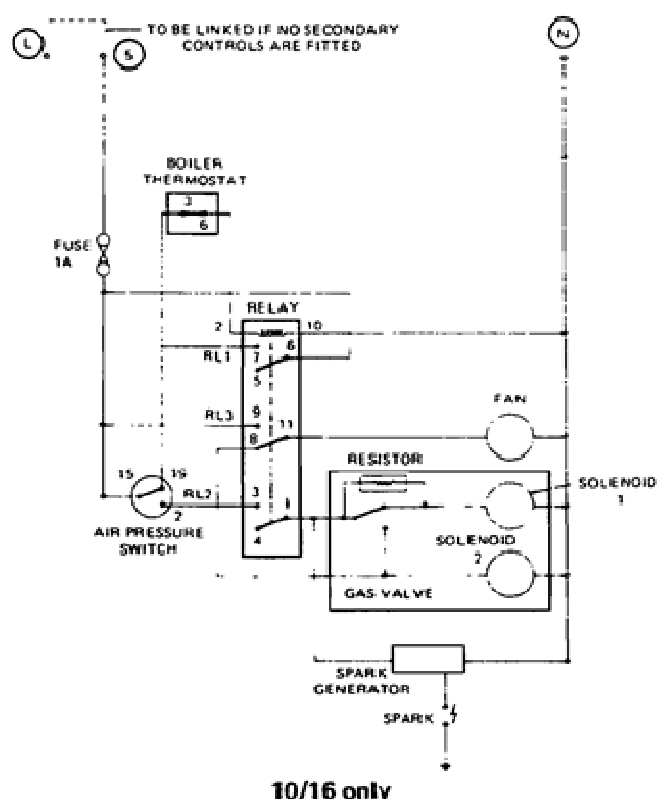
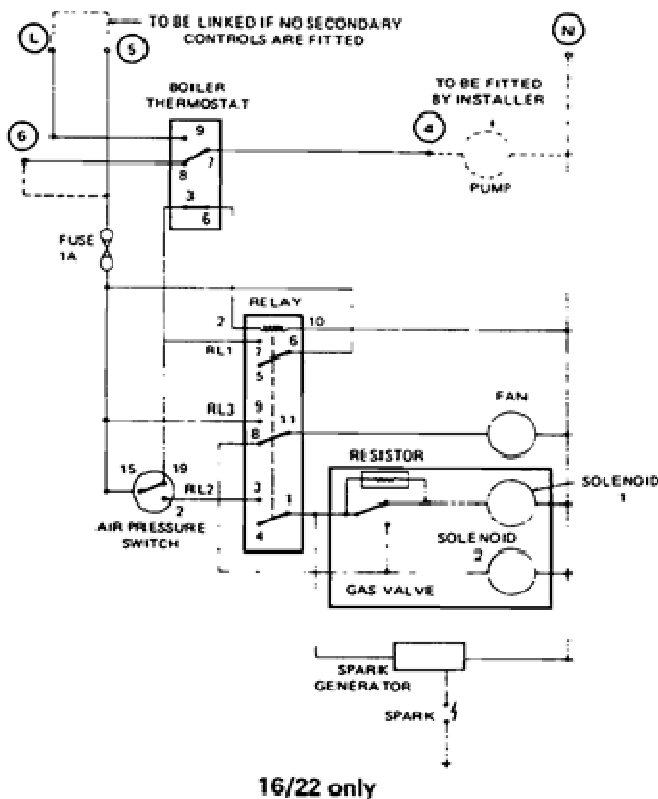


Fig. 10 PRINCIPLE OF WIRING



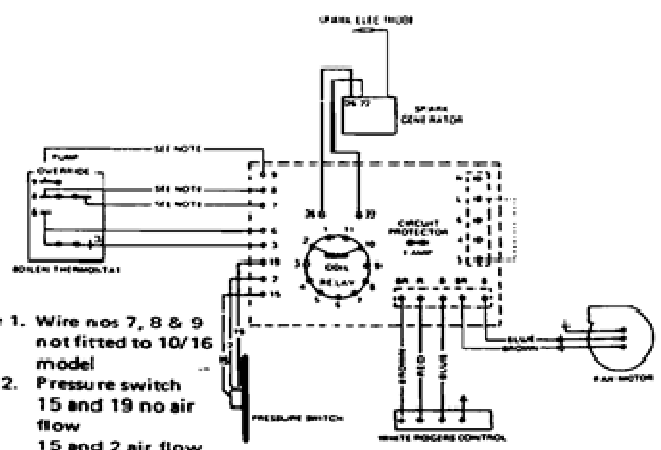
FUNCTIONAL FLOW DIAGRAMS

**WARNING:** When fitting the bolts in A, the weight of the boiler could distort the boiler support bracket so making it difficult to line up the bolt holes in the boiler back plate with those in the plenum chamber. If this should occur, the weight of boiler should be supported until the bolts are correctly engaged.

B. Fit the fan in position and secure it to the boiler backplate with the three bolts, numbered 8 to 10 on Fig. 9. Connect the two mains electrical leads to their connections on the boiler backplate and the earth lead to the earth screw also on the backplate.

**Warning:** It is very important that when tightening the bolts in operations A and B that good seals are made. All bolts must be tight.

C. Refit the fluehood to the heat exchanger, ensuring that a good seal is made at the plenum and that



Note 1. Wire nos 7, 8 & 9 not fitted to 10/16 model  
 2. Pressure switch 15 and 19 no air flow 15 and 2 air flow

Fig. 11 BOILER WIRING DIAGRAMS

all the plenum fixing bolts have been fitted and are tight. Secure the hood in position with the four nuts and washers; ensure the nuts are tight, and that the hood makes a good seal with the heat exchanger.

- D. Fit the combustion chamber front cover, securing it with the four screws (Accessories Card Item F).
- E. Unscrew the nuts and remove and discard the two metal feet taking care not to damage the capillary of the mercury vapour flame safety switch.
- F. Connect the main gas supply to the length of pipe fitted to the 1/2 in. BSP gas cock.
- G. Connect the short lengths of pipe previously fitted to the boiler, to the system pipework, then fill and vent the water system and test for leaks. Rectify if necessary.

## 6. WIRING – See Fig. 11

### THIS APPLIANCE MUST BE EARTHED

Care must be taken to ensure that all wiring to the boiler is kept clear of sharp edges and hot surfaces.

The boiler terminal strip situated on the control panel is not designed to accept wiring from all the on-site system controls and therefore, the installer will usually need to incorporate a suitable junction box. The principle of wiring up the boiler and site controls is shown in Fig. 10. However, the layout of a particular system will itself govern the most economical location for the junction box and its terminals.

Wire up the boiler and system controls as illustrated in Fig. 12, 13, 14, 15 or 16 depending on the type of system installed. The wiring arrangements shown outline only the basic control requirements, and will therefore require on-site interpretation of the various boiler installation requirements.

If a Potterton EP 2000 Programmer is not being fitted, but a three terminal time clock is to be installed to control the systems illustrated in Fig. 12, 13, 14, 15, or 16 the time clock should be wired as follows:—

- Live to Time Clock Live
- Neutral to Time Clock Neutral
- Earth to Time Clock Earth
- Wires normally connected to EP 2000 Terminals 3 & 4 to Time Clock Switch

A low limit thermostat can be installed to override the "OFF" setting of the time control if the temperature where the thermostat is situated, falls below the thermostat setting. Where an EP 2000 or equivalent Programmer is installed, a double pole or double outlet thermostat may be necessary; for the electrical connections and type required, see the relevant system wiring diagram. Where only a time clock is fitted, the thermostat need only be a single pole type with its contact wired in parallel with the clock switch.

### MID POSITION ZONE VALUE

If a three way (proportioning diverter) valve with a mid-position is being fitted in the system, the following instructions must be adhered to in addition to the valve manufacturers wiring information:

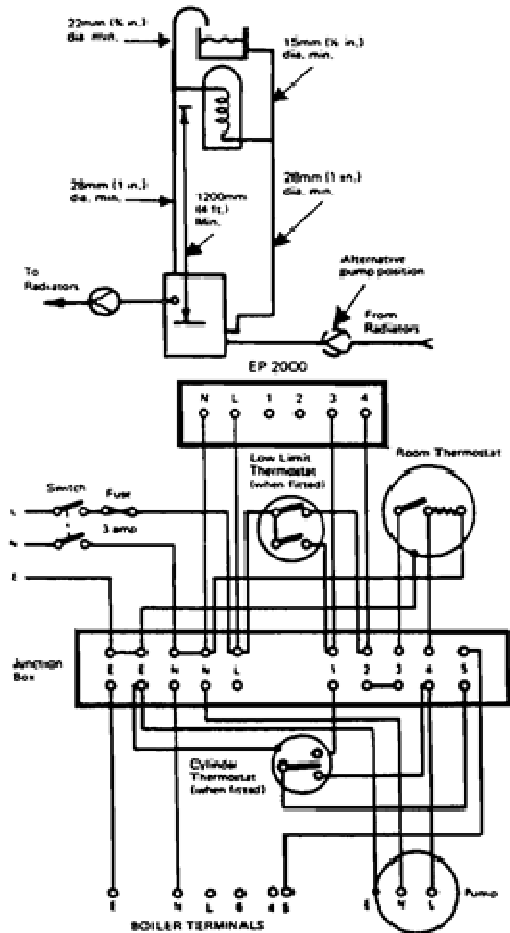
1. Neutral and earth connections must be made to boiler terminals N and E.
2. The switched supply from the system control circuit for the boiler, must be connected to boiler terminal 5.
3. On 16–22 boilers, the live supply to the pump must be taken from the boiler terminal 4, with terminal 5 and 6 looped together and in addition to note 2 a live connection made to boiler terminal L.

4. On 10–16 boilers, the live supply to the pump must be taken from the supply to boiler terminal 5.

When all wiring is complete, hinge down the controls panel to gain access to the boiler front cover lower securing points, then fit the front cover to the boiler, securing it with the four captive bolts.

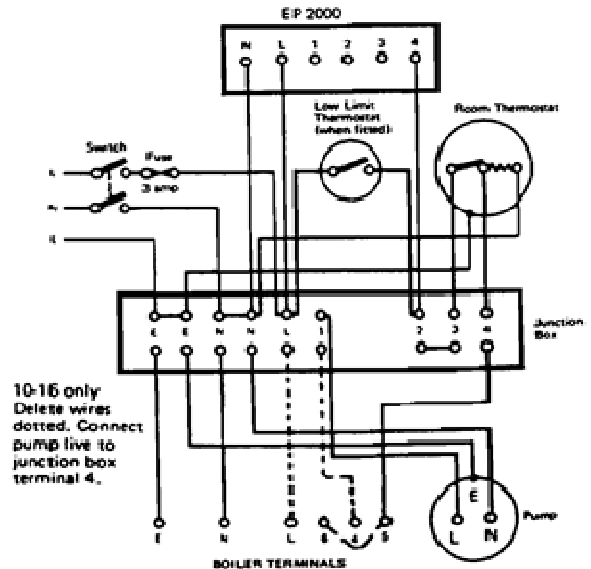
Ensure that a good seal is obtained around the perimeter of the cover. Fit the thermostat knob (Accessories Card Item G).

Fig. 12 GRAVITY HOT WATER WITH PUMPED CENTRAL HEATING



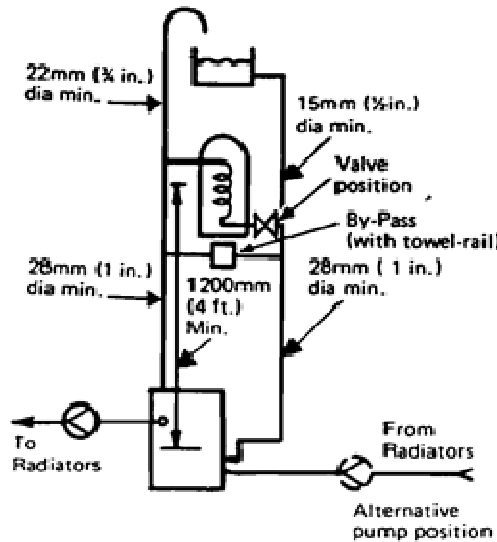
Note 1: When a cylinder thermostat is not fitted, a direct connection must be made between junction box terminal 1 and boiler terminal 5.

GRAVITY HOT WATER WITH PUMPED CENTRAL HEATING



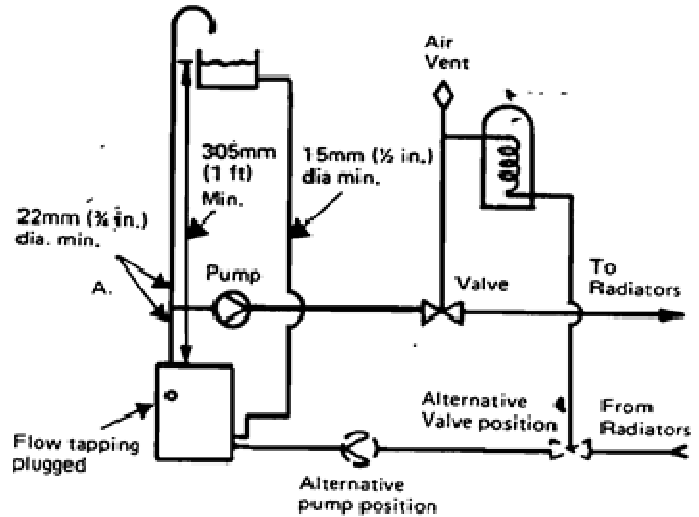
PUMPED CENTRAL HEATING ONLY

**Fig. 13 GRAVITY HOT WATER WITH TEMPERATURE CONTROL AND PUMPED CENTRAL HEATING**

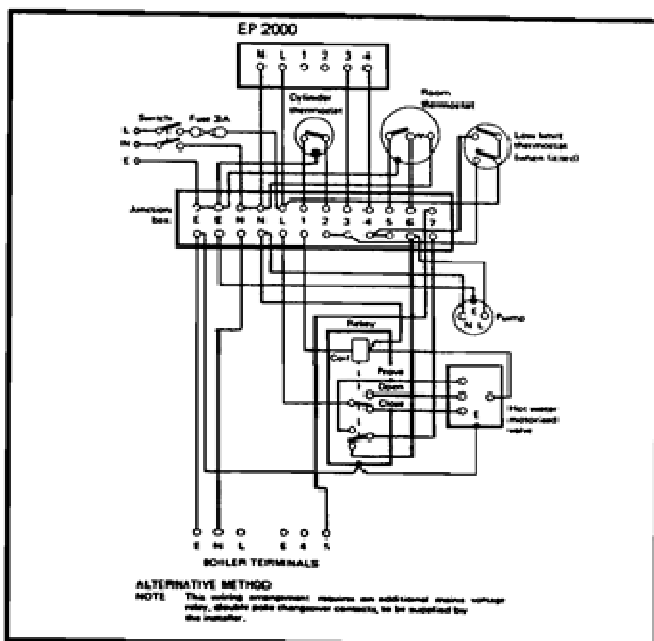
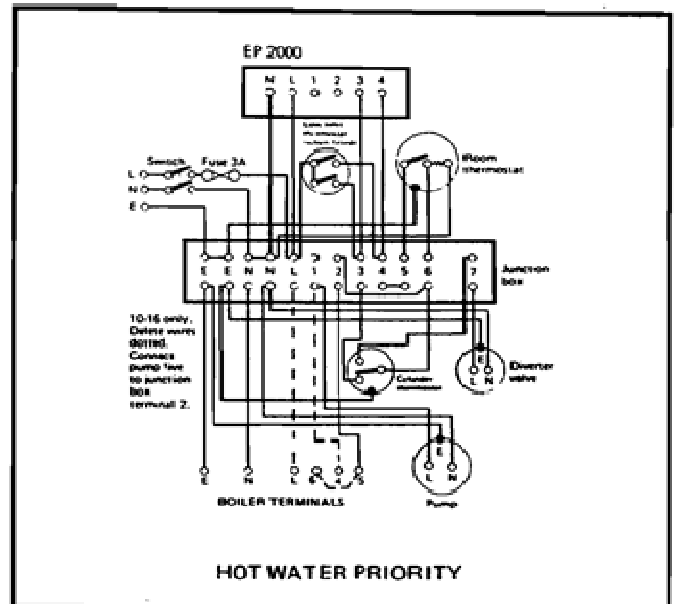
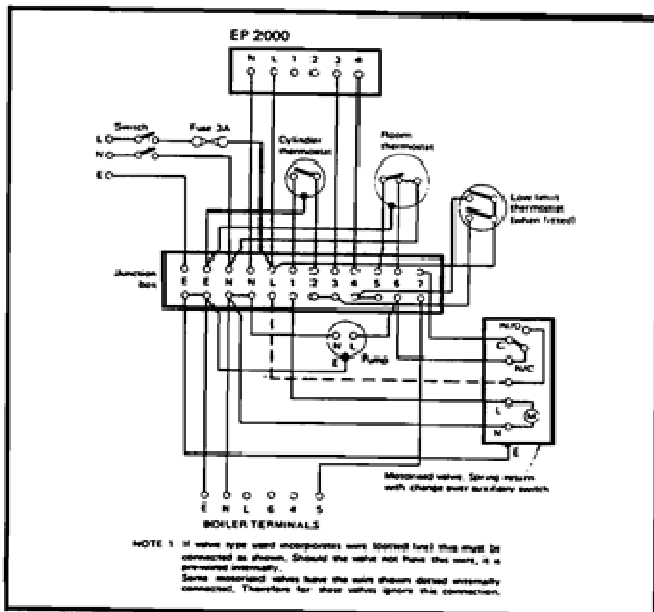


The by-pass is not required on 10-16 boilers, when the valve used has proving contacts to control the boiler

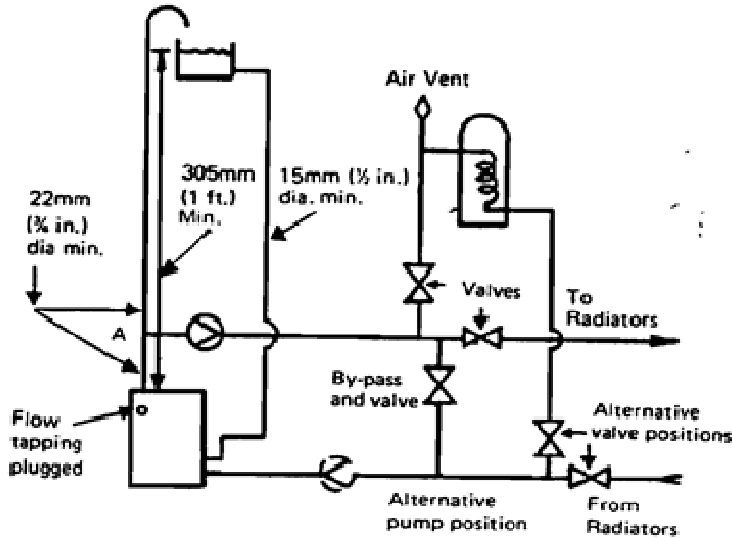
**Fig. 14 FULLY PUMPED WITH TWO POSITION DIVERTER VALVE**



A. Junction between vent and pumped circuit to be as close to boiler as possible — Max. distance 910mm (3 ft.)

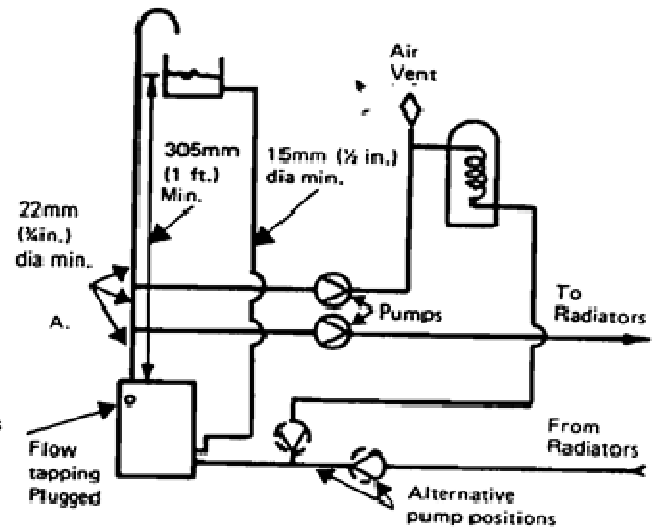


**Fig. 15 FULLY PUMPED WITH ONE OR TWO ZONE VALVES SPRING RETURN**



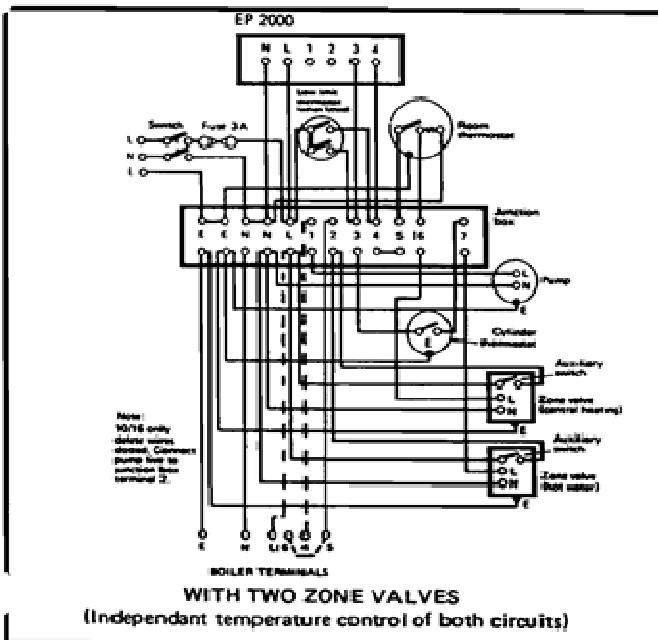
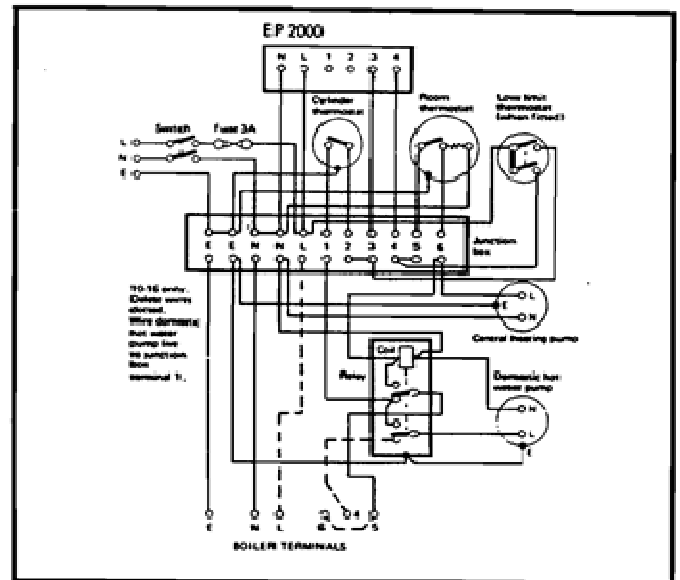
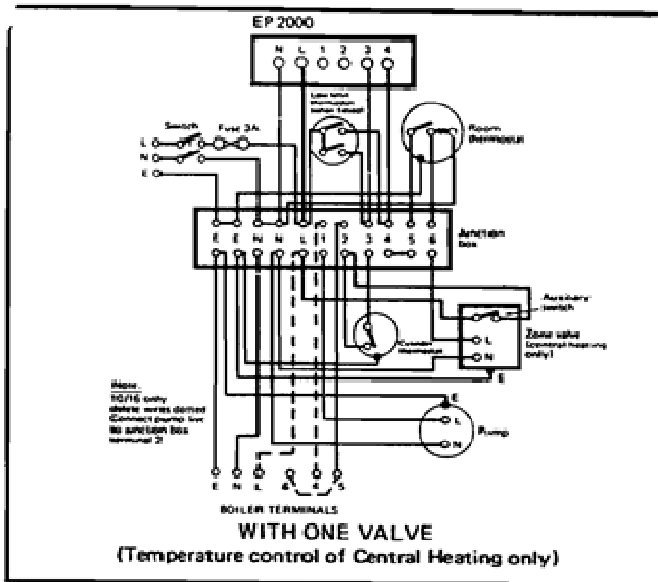
A. Junction between vent and pumped circuit to be as close to boiler as possible – Max. distance 910mm (3ft.)

**Fig. 16 FULLY PUMPED USING TWO PUMPS**



A. Junction between vent and pumped circuit to be as close to boiler as possible – Max. distance 910mm (3 ft.)

B. To stop intercirculation, a non-return valve should be fitted in each circuit.



**NOTE:** These system diagrams, Figs. 12 to 16, are schematic only. Installers are advised to read "The System" on page 4 and BS. 5376 and BS. 5449 Part 1.

## 7. FIRST LIGHTING

**WARNING: BEFORE LIGHTING THIS BOILER, ENSURE THAT THE FRONT COVER HAS BEEN CORRECTLY FITTED AND THAT THE EDGE OF THE COVER MAKES A TIGHT SEAL WITH THE SEALING STRIP IN THE GROOVE AROUND THE BOILER BACKPLATE.**

- A. Check that the main electricity supply to the boiler is switched off and that the boiler thermostat is in the off position.
- B. Turn on the main gas supply.  
**WARNING: OPEN ALL WINDOWS AND EXTINGUISH ANY NAKED LIGHTS IN THE ROOM AND PUT OUT PIPES AND CIGARETTES.**
- C. Break the union at the boiler main inlet cock, then open the cock and purge air from the supply pipe.
- D. Close the cock, remake the union then re-open the cock and test for gas soundness using a soap solution, taking care not to splash the boiler electrics.  
**WARNING: DO NOT USE A NAKED FLAME.**
- E. Ensure that the system is full of water and that the pump and radiator isolating valves are open.
- F. Ensure that the time control, if fitted, is in an on condition, and that the room and/or cylinder thermostats, where fitted, are set to high temperatures.
- G. Switch on the main electricity supply to the boiler.
- H. Turn the boiler thermostat on and to a high setting and after a period of time the main burner will light, which can be observed through the site glass in the front cover of the boiler. The time period can vary upwards of 45 seconds, depending on the amount of air in the pipework.
- J. Turn off the boiler thermostat.

**NOTE:** There could be a delay in lighting if the control knob is switched on and off and then on again rapidly.

## 8. SETTING AND CHECKING OF CONTROLS

### A. Gas Rate and Main Burner Pressure Setting

- (1) Fit a pressure gauge to the pressure test nipple in the multi-functional control.
- (2) Turn on the boiler thermostat and ensure that the main burner is alight then check that the burner pressure is in accordance with Table 1.
- (3) If burner pressure adjustment is necessary, remove the screwed cap from the multi-functional control, see Fig. 1 and turn the screw beneath clockwise to increase pressure or anti-clockwise to decrease. Refit the screwed cap when the pressure is correct. Shut down the boiler, remove the pressure gauge and refit the screw in the pressure test nipple.
- (4) Isolate the main electrical supply to the boiler, then hinge up and secure the controls panel.
- (5) Remove the thermostat knob, then slide on the controls cover and secure it with the captive screw.
- (6) Refit the thermostat knob, then switch on the main electrical supply to the boiler.

- (7) With the burner set to its correct pressure, the firing rate given in Table 1 should also be obtained and this should be checked by meter reading over a period of at least 5 minutes once the boiler is hot.

### B. Pilot Burner

- (1) The pilot is preset and no adjustment is required or available.

### C. Boiler Thermostat

- (1) At its maximum and minimum settings, the thermostat should control the water flow temperature at approximately 55°C – 82°C (130°F – 180°F) respectively.
- (2) The thermostat has been calibrated by the makers and no attempt should be made to re-calibrate it on site. Turn the thermostat to the off position and check that the main burner shuts down.

### D. Pump Over-Run Thermostat – 16–22 Boiler Only

- (1) In fully pumped systems, the over-run thermostat will keep the pump running when the boiler has shut down, as long as the water temperature within the boiler is above a predetermined limit.

## OTHER BOILER CONTROLS

All boiler mounted controls are designed so that if any fault should occur they will fail safe. No further setting or checking is necessary.

## REMOTE CONTROLS

Check that any other remote control connected in the system such as programmers and thermostats, control the boiler as required.

## USER'S GUIDE

A user's guide is provided with this boiler but the householder should have the operation of the boiler and system explained by the installer.

TABLE 1.

BOILER	10–16	16–22
Input	13.4 to 20.9 kW (45,600 to 71,400 Btu/h)	22.5 to 29.6 kW (76,800 to 101,150 Btu/h)
Output into water	10.0 to 16.1 kW (34,000 to 55,000 Btu/h)	16.1 to 22.0 kW (55,000 to 75,000 Btu/h)
Output into air (Approx)	0.3 to 0.4 kW (957 to 1499 Btu/h)	0.3 to 0.4 kW (998 to 1314 Btu/h)
Burner pressure	6.0 to 13.5 m.bar (2.4 to 5.4 in.w.g.)	8.5 to 14.0 m.bar (3.4 to 5.6 in.w.g.)
Injector size	3.6mm	4.2mm
No. of Injectors	1	1
Gas Rate	1.3 to 2.0 cu.m/h (45.5 to 71.5 cu.ft/h)	2.2 to 2.9 cu.m/h (77 to 101 cu.ft/h)
B.G. Code No.	41.601.34	41.601.35
Potterton Code	P.C.A.	P.C.B.

"All descriptions and illustrations contained in this leaflet have been carefully prepared but we reserve the right to make changes and improvements in our products which may affect the accuracy of the information contained in this leaflet"