

FF55 - FF75

## Installation & Service Instructions

### **About the Boiler**

See inside cover for models covered by these instructions.

This is a Wall Mounted Fan Assisted Balanced Flue Gas Boiler.

This boiler is for use with Natural Gas (G20) only at 20 mbar and for use in GB & IE.

### **About Safety**

The Gas Safety (Installation and Use) Regulations 1998.

“ In your own interest, and that of safety, it is law that all gas appliances are installed by competent persons, in accordance with the above regulations. Failure to install appliances correctly could lead to prosecution.”

Installation must be in accordance with the Installation & Service Instructions and the rules in force.

**Leave these instructions and the Benchmark Log Book with the user for use on future calls.**

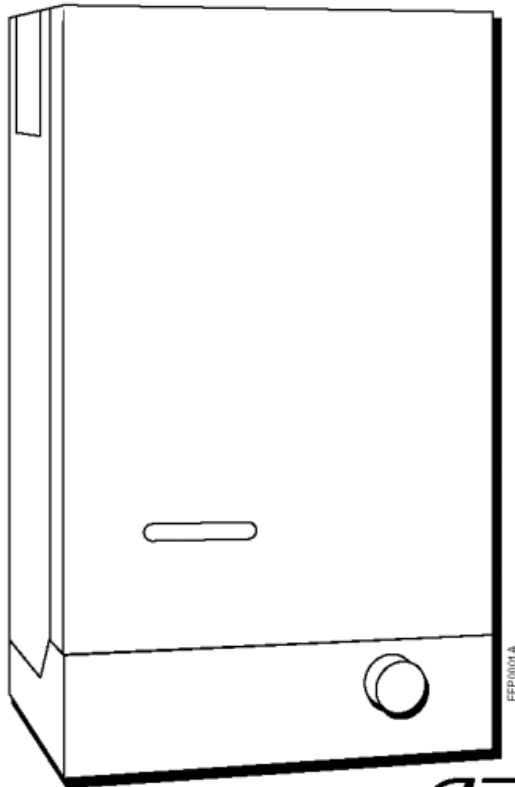

*The code of practice for the installation, commissioning & servicing of central heating systems*

---

## Contents

<a href="#">Technical Data</a>	3
<a href="#">Introduction</a>	4
1. <a href="#">Installation Requirements</a>	4
1.1 <a href="#">Health &amp; Safety Information</a>	4

1.2	<a href="#">Codes of Practice</a>	4
1.3	<a href="#">Gas Supply</a>	5
1.4	<a href="#">Electricity Supply</a>	5
1.5	<a href="#">Location of Boiler</a>	5
1.6	<a href="#">Air Supply</a>	7
1.7	<a href="#">Flue Systems</a>	7
1.8	<a href="#">Flue Terminal Location</a>	8
1.9	<a href="#">The System</a>	9
<b>2.</b>	<b><a href="#">Installation</a></b>	<b>13</b>
2.1	<a href="#">Unpack the Boiler and Flue</a>	13
2.2	<a href="#">Fixing Template</a>	13
2.3	<a href="#">Boiler Mounting Plate</a>	13
2.4	<a href="#">The Flue</a>	14
2.5	<a href="#">Air/Flue Duct Assembly</a>	14
2.6	<a href="#">Prepare the Boiler</a>	15
2.7	<a href="#">Install the Boiler</a>	16
2.8	<a href="#">Connect System Pipework</a>	18
2.9	<a href="#">Overheat Thermostat Bulb Position</a>	19
2.10	<a href="#">Electrical Connections</a>	19
2.11	<a href="#">Fitting Side Infill Panels</a>	20
<b>3.</b>	<b><a href="#">Commissioning</a></b>	<b>21</b>
3.1	<b>Commission the Boiler</b>	20
<b>4.</b>	<b><a href="#">To Service the Boiler (s) &amp; Component Replacement(r)</a></b>	<b>25</b>
4.1	<a href="#">(s) Prepare Boiler for Servicing</a>	26
4.2	<a href="#">(s) Heat Exchanger</a>	26
4.3	<a href="#">(s) Pilot Burner</a>	26
4.4	<a href="#">(s) Combustion Chamber Insulation</a>	27
4.5	<a href="#">(s) Main Burner</a>	27
4.6	<a href="#">(s) Fan</a>	27
4.7	<a href="#">(s) Case Seal</a>	27
4.8	<a href="#">(r) Gas Control Valve</a>	28
4.9	<a href="#">(r) Fan</a>	28
4.10	<a href="#">(r) Main Burner</a>	28
4.11	<a href="#">(r) Pilot/Ignition Electrode</a>	28
4.12	<a href="#">(r) Combustion Chamber Insulation</a>	29
4.13	<a href="#">(r) Fuse</a>	29
4.14	<a href="#">(r) Electronic Control</a>	29
4.15	<a href="#">(r) Pressure Switch</a>	29
4.16	<a href="#">(r) Overheat Thermostat</a>	30
4.17	<a href="#">(r) Boiler Thermostat</a>	30
4.18	<a href="#">(r) Gravity HW/Pump Overrun Thermostat</a>	30
4.19	<a href="#">(r) Heat Exchanger Pipe Seal</a>	30
<b>5.</b>	<b><a href="#">Fault Finding</a></b>	<b>32</b>
<b>6.</b>	<b><a href="#">Optional Extras and Accessories</a></b>	<b>33</b>
<b>7.</b>	<b><a href="#">Short List of Spares</a></b>	<b>34</b>

The models covered by these instructions are:-

FF 55 from Potterton - G.C. No. 41 590 71

FF 75 from Potterton - G.C. No. 41 590 72

The boiler model and serial number are given on labels; one on the underside of the controls cover; the other to the right hand side of the thermostat knob, and visible after removal of the controls cover.

Potterton is a member of the Benchmark initiative and fully supports the aims of the programme. Benchmark has been introduced to improve the standards of installation and commissioning of central heating systems in the UK and to encourage the regular servicing of all central heating systems to ensure safety and efficiency.

**Important-** Failure to install and commission this appliance to manufacturer's instructions may invalidate the warranty. This note does not affect your statutory rights.

**Important** - This product should be lifted and handled by two people. Stooping should be avoided, and protective equipment worn when necessary. Carrying and lifting equipment should be used as required, for example when installing in a loft space.

**Note:** Boiler Clearances are shown on [Page 5](#) and Boiler Dimensions are shown on [Page 7](#)

**SAFETY, PERFORMANCE & QUALITY**

Profile boilers have been assessed by a Government appointed Notified Body and shown to meet the 'Essential Requirements' of the European Gas Appliance Directive.

The Directive lays down requirements for the safety and efficiency of the appliance, together with its design, construction, and use of materials. It also requires the production process to be covered by an approved and monitored system of quality assurance.

Page 2

## Technical Data

Boiler model		
	FF55	FF75
Output kW (Btu/h)	17.58(60,000)	23.45(80,000)
Input kW (Btu/h) max	21.66(73,900)	28.88(98,500)
Gas rate m <sup>3</sup> /h (ft <sup>3</sup> /h) max	2.02 (71.3)	2.69 (95.1)
Burner Pressure max	13.0 (5.2)	12.2 (4.9)
mbar (in wg)		
Injector Size mm	3.8	4.4
Maximum Working Head	30.5 m (3 bar)	
Minimum Working Head	305 mm	
Minimum Circulating Head - Gravity	1.2 m	
Gas Supply Pressure	20 mbar	
Gas Supply Connection	Rc. ½ (½ in BSP Female)	
Maximum Flow Temperature	82 °C	
Flow/Return Connections	28 mm copper	
Water Content	6.5 litres	
Appliance Weight Installed	- Lift	53.0 kg
	- Dry	62.0 kg
Electricity Supply	230 v ~ 50 Hz Fused at 3A	
Internal Fuse	Type 1A	
Power Consumption	80 Watts (excluding pump)	
Classifications		
	CAT I 2H	
	2H G20 20 mbar	
	C13, C33	
	IP20	

## SEDBUK Declaration

Model	Seasonal Efficiency (SEDBUK) (%)
FF55	78.2
FF75	78.4

This value is used in the UK Government's Standard Assessment Procedure (SAP) for energy rating of dwellings. The test data from which it has been calculated have been certified by 0063.

Page 3

## Introduction

### Gas Safety (Installation & Use) Regulations 1998.

This appliance must be installed and serviced by a competent person, in accordance with the above regulations.

In the UK 'Corgi' Registered Installers (including the regions of British Gas Plc) undertake to work to a safe and satisfactory standard.

Failure to install appliances correctly could lead to prosecution.

It is in your own interest, and that of safety, to ensure that the regulations are complied with.

FF boilers are fully automatically controlled, wall mounted, fan powered, balanced flue appliances using a cast iron heat exchanger and are available in outputs ranging from 17.58 - 23.45 kW (60,000 - 80,000 Btu/h)

The boilers which are designed to provide domestic hot water and/or central heating must be used on INDIRECT hot water systems only. The cast iron heat exchangers are suitable for use on open vented gravity domestic hot water/ pumped central heating systems or fully pumped systems which may be sealed or open vented.

Before installing the boiler on a gravity domestic hot water system, consult the current building regulations as to any restrictions.

The boilers are for use on Natural Gas (G20) only.

Samples of the FF gas boilers have been examined by Advantica Technologies Limited, a United Kingdom Notified Body. The range is certified to comply with the essential requirements of the Gas Appliance Directive 90/396/EEC, the Low Voltage Directive 72/23/EEC and shows compliance with the Electro Magnetic Compatibility Directive 89/336/EEC, the Boiler Efficiency Directive 92/42/EEC and are therefore permitted to carry the CE Mark.

### **Delivery & Kits Available**

The unit is delivered in two packages (1) the boiler with fittings and (2) the flue/terminal assembly. All boilers can be supplied with either of the following types of flue system:

- Standard horizontal flue system suitable for wall thickness of 100 mm to 510 mm.
- 2 metre horizontal flue system which provides a maximum flue length of 1955 mm.
- Vertical flue system which allows the flue to pass through a flat roof and terminate at a maximum height of 1980 mm measured from the top of the boiler case.

Various kits are available for the Profile range of boilers, see [page 33](#).

## **1. Installation Requirements**

### **1.1 Health and Safety Information for the Installer and Service Engineer**

Under the Consumer Protection Act 1987 and Section 6 of the Health and Safety at Work Act 1974, we are required to provide information on substances hazardous to health.

Small quantities of adhesives and sealants used in the product are cured and present no known hazards.

The following substances are also present.

#### **Insulation and Seals**

**Material** - Man Made Mineral Fibre.

**Description** - Boards, Ropes, Gaskets.

**Known Hazards** - Some people can suffer reddening and itching of the skin. Fibre entry into the eye will cause foreign body irritation which can cause severe irritation to people wearing contact lenses. Irritation to respiratory tract.

**Precautions** - Dust goggles will protect eyes. People with a history of skin complaints may be particularly susceptible to irritation. High dust levels are only likely to arise following **harsh** abrasion. In general, normal handling and use will not present high risk, follow good hygiene practices, wash hands before, touching eyes, consuming food, drinking or using the toilet.

**First Aid** - Medical attention must be sought following eye contact or prolonged reddening of the skin.

#### **Thermostat**

**Material** - Contains very small quantity of xylene.

**Description** - Sealed phial and capillary containing liquid.

**Known Hazards** - Irritating to skin, eyes and throat. Vapour is harmful. Inflammable - do not extinguish with water.

**Precautions** - Do not incinerate. Avoid contact with broken/leaking phials. Do not purposely puncture.

**First Aid** - Medical attention must be sought following eye/skin contact, wash with clean water.

Page 4

---

### **1.2 Codes of Practice**

The boiler must be installed in accordance with: The Gas Safety (Installation and Use) Regulations 1998 and the current issue of:-

The Building Regulations, Building Standards (Scotland) Regulations, Local Building Regulations, Model and local Water Undertaking Bye-laws, IEE Wiring Regulations and Health & Safety Document No. 635 "The Electrician At Work Regulations 1989".

### 1.3 Gas Supply

The meter and supply pipes must be capable of delivering this quantity of gas in addition to the demand from any other appliances in the house and must be governed at the meter.

The complete installation must be tested for gas soundness and purged as described in BS6891.

### 1.4 Electricity Supply

230V ~ 50Hz via a fused double pole switch with a contact separation of at least 3 mm in both poles adjacent to the boiler. Power consumption is approximately 80W. There must be only one common isolator for the boiler and its control system and it must provide complete electrical isolation.

Fuse the supply at 3 A. The minimum requirement for the power supply cable is that it should be a PVC sheathed cord at least 0.75 mm<sup>2</sup> (24 x 0.2 mm) (code designation HO5 VV-F or HO5 VVH2-F) as specified in table 16 of BS6500:1984.

All wiring external to the boiler shall comply with the latest IEE Wiring Regulations, and any local regulations which apply.

#### **WARNING: THIS APPLIANCE MUST BE EARTHED.**

In the event of an electrical fault after installation of the boiler, preliminary electrical systems checks must be carried out i.e. Earth Continuity, Short Circuit, Polarity and Resistance to Earth.

### 1.5 Location of Boiler

The boiler is not suitable for external installation and should not be fitted directly above a cooking appliance.

The boiler must be installed so that the flue terminal is exposed to the external air. It is important that the position of the terminal allows the free passage of air across it at all times.

The boiler must be mounted on a flat wall which is sufficiently robust to take the weight of the boiler.

The boiler is suitable for installation to a combustible wall e.g. wood cladding, provided that the flue duct is not closer than 25 mm to combustible material. A metal sleeve should be installed to surround the flue duct to provide a 25 mm annular space. Further guidance is given in BS5440:1:2000, sub-clause 4.4.

If the boiler is to be installed in a timber framed building it should be fitted in accordance with the Institute of Gas Engineers document IGE/UP/7/1998 (also, British Gas Service publication Part 19 - Building and Kitchen Work). If in doubt advice must be sought from Potterton.

The boiler may be installed in any room, although particular attention is drawn to the requirements of the current IEE Wiring Regulations and, in Scotland, the electrical provisions of the Building Standards applicable in Scotland with respect to the installation of the boiler in a room containing a bath or shower.

Where a room-sealed appliance is installed in a room containing a bath or shower, any electrical switch or appliance control, utilising mains electricity should be so situated that it cannot be touched by a person using the bath or shower.

Where the installation of the boiler will be in an unusual position, special procedures may be necessary and BS6798 and BS5546 give detailed guidance on this aspect.

A cupboard or compartment used to enclose the boiler must be designed and constructed specifically for this purpose. An existing cupboard or compartment may be used provided that it is modified for the purpose. Details of essential features of cupboard/compartment design including airing cupboard installations are given in BS6798 and BS5546 and should be complied with.

The boiler requires the clearances shown after installation for correct operation and servicing:

Front: 610 mm

Sides: 5 mm

Top: 50 mm unless optional pump cover is fitted when clearance should be 178 mm

Bottom: 100 mm

Additional clearances are required during installation of this boiler and 127 mm is required at the top for access to the pipe connections.

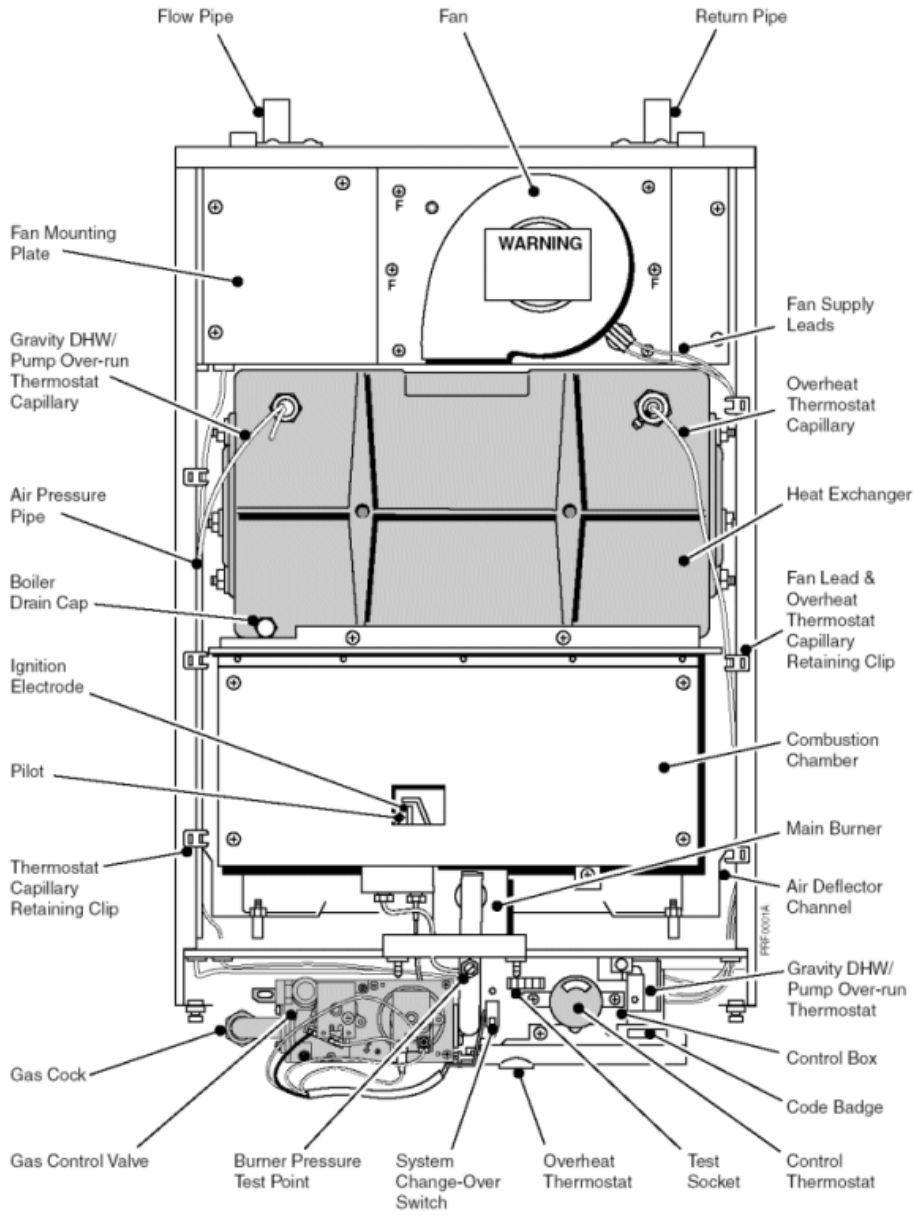
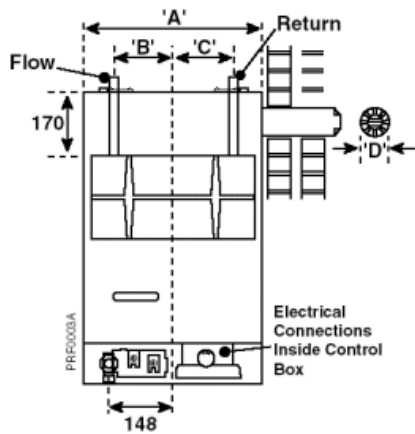

Fig. 1



Model	FF55	FF75
Dimension 'A'	425	425
(mm) 'B'	150	150
'C'	143	143
'D'	107	107

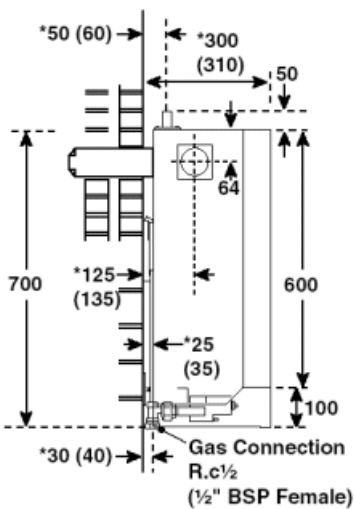

Fig. 2

\* Note: If pipework is to be run down the back of the boiler, the normal clearance of 28 mm between the rear of the boiler and wall can be increased to 38 mm if desired by inverting the boiler mounting plate during installation.

Dimensions in brackets ( ) apply when the mounting plate is inverted.

## 1.6 Air Supply

The air requirements must meet BS 5440 Part 2.

The room in which the boiler is installed does not require a purpose provided air vent.

**Ventilated Cupboard/Compartment:** If the boiler is installed in a cupboard or compartment, permanent air vents are required in the cupboard or compartment, one at high level and one at low level, either direct to the outside air or to a room. Both high level and low level air vents must communicate with the same room or must be on the same wall to outside air. Both the high level and low level vent must each have a free area as stated below. The free area of each vent may be halved if the ventilation is provided directly from outside.

Models: FF55: 206 cm<sup>2</sup>

FF75: 277 cm<sup>2</sup>

If the boiler is installed in a cupboard or compartment with a door, allow at least 15 mm clearance between the front of the boiler and the door for air movement.

## 1.7 Flue Systems

The flue system can be run from either the left, right, rear or top of the boiler.

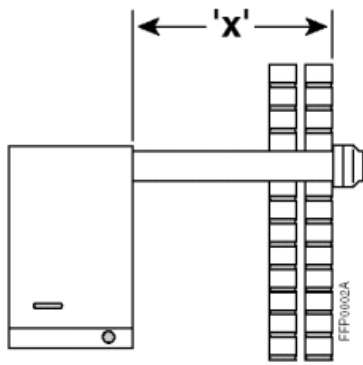

Fig. 3

	Maximum Length 'X'
Standard Flue	510 mm
2 Metre Flue	1995 mm

### 1.8 Flue Terminal Location

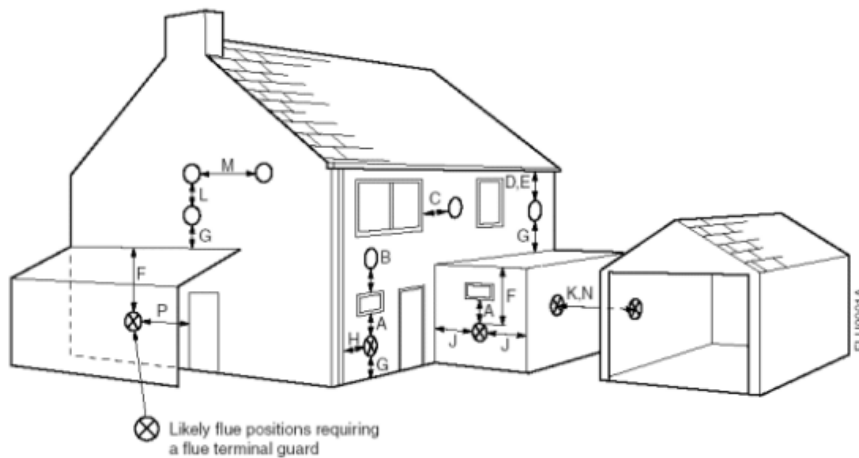

Fig. 4

#### Horizontal Terminal Position with Minimum Distance (mm) Fanned Draught Balanced Flue

A	Directly below an opening, air brick, opening window etc	300
B	Above an opening, air brick, opening window, etc	300
C	Horizontally to an opening, air brick, opening window etc	300
D	Below a gutter, or sanitary pipework	75
E	Below the eaves	200
F	Below a balcony or carport roof	200
G	Above ground, roof or balcony level	300
H	From vertical drain/soil pipe work	150
J	From an internal or external corner	300
K	From a surface or <i>boundary</i> facing the terminal	600
L	Vertically from a terminal on the same wall	1500
M	Horizontally from a terminal on the same wall	300
N	From a terminal facing the terminal	1200
P	From an opening in a <i>carport</i> (e.g. door, windows) into the <i>building</i>	1200

- Where a horizontal flue is sited less than 2 m above a balcony, above ground, or above a flat roof to which people have access, a suitable terminal guard must be fitted. This serves two purposes, to protect the terminal against damage or



interference and to protect passers-by. A terminal guard is available (Part No. 205792), this should be fitted centrally about the terminal.

**Note:** Where a flue terminal is installed less than 1 metre from a plastic, or painted gutter, or 500 mm from painted eaves, an aluminium shield 1 metre long, should be fitted to the underside of the gutter or painted surface. A suitable wall plate should be fitted to the painted wall surface of a mobile home.

- **IMPORTANT:** It is absolutely ESSENTIAL, to ensure that products of combustion discharging from the terminal cannot re-enter the building, or any other adjacent building, through ventilators, windows, doors, natural air infiltration, or forced ventilation/air conditioning. If products of combustion are found to be re-entering any building, the appliance MUST be turned OFF IMMEDIATELY.

### Reduced Clearances

The FF range of boilers has been tested and approved for use with certain clearances less than those shown above.

**Only one of these reductions may be used on a single installation.**

D	Below a gutter, or sanitary pipework	25
E	Below the eaves	25
F	Below a balcony or carport roof	25
H	From vertical drain/soil pipe work	75
J	From an internal or external corner	25

Page 8

---

## 1.9 The System

If plastic pipe is used for the central heating circuit there must be a run of at least 1 m of un-insulated copper pipe from the boiler flow and return connections.

The boiler must be used on Indirect hot water systems only. It is suitable for use on open vented gravity domestic hot water/pumped central heating systems or fully pumped systems which may be sealed or open vented.

The system should be designed so that the maximum static head does not exceed 30.5 m (100 ft) and a minimum of 150 mm (6 in).

Gravity domestic hot water circuits should have a minimum circulating head of 1.2 m (4 ft).

To ensure optimum boiler performance on both gravity hot water and fully pumped systems a change-over switch is incorporated in the boiler control box. The boiler is supplied with the switch set for sealed or open vented fully pumped systems.

If the boiler is to be used on a system with gravity hot water the switch must be set to the GRAVITY position. In addition, the bulb of the overheat thermostat should be repositioned as shown in [Fig. 21](#).

To prevent reverse circulation in the gravity circuit when the pump is running, an injector disc is provided to form an injector tee at the return connection on the boiler, see [Fig. 20](#).

On all systems the pump live connection should be wired to the boiler terminal block, it will then be controlled by the pump overrun. This will ensure that the pump will continue to run after boiler shut down if the water temperature is high, thus preventing nuisance operation of the overheat thermostat.

It is important that where electrically operated zone valves are used the boiler is wired so it does not cycle when the zone valves are closed. Also, systems fitted with controls that close both hot water and central heating circuits while the boiler is still hot, must be fitted with a by-pass circuit to dissipate the residual heat from within the boiler.

Drain off taps should be fitted in the pipework close to the boiler and in the low points of the system.

**Note:** Although the system can be emptied using the drain off taps installed in the pipework around the system, to empty the boiler it is necessary to remove the drain off cap positioned within the boiler case.

### Combined Gravity Hot Water, Pumped Central Heating Systems

Where a cylinder thermostat and zone valve is used to control the temperature of the hot water it is recommended that a by-pass be installed in the gravity circuit. A suggested method of doing this is shown in [Fig. 8](#) where the bathroom radiator is connected into the gravity circuit and is fitted with two lockshield valves. Mechanically operated thermostatic domestic hot water temperature control valves which allow the boiler to operate when the valve is closed or partially closed MUST NOT BE FITTED.

### Fully Pumped Systems

With the change-over switch in the control box set at the FULLY PUMPED position, the pump will be controlled by an overrun thermostat. This will ensure that the pump will continue to run after boiler shut down if the water temperature is high, thus

preventing nuisance operation of the overheat thermostat.

If a three port valve is used as shown in [Fig. 5](#) a by-pass is not necessary since one circuit is always open.

Where a pair of two port valves are used, a by-pass is necessary. The total length of the by-pass circuit taken from the boiler connections should be greater than 4 metres of 22 mm pipe. It should be fitted with a lockshield valve and be adjusted to maintain a minimum flow through the boiler of 4.5 litres/min (1 gal/min).

Systems fitted with controls which allow the boiler to operate when both the hot water and central heating circuits are closed i.e. mechanically operated thermostatic control valves, must be fitted with a bypass circuit of:-

1. Dissipating a minimum of 1 kW (3400 Btu/h).
2. Maintaining a minimum water flow rate through the boiler of 9 litres/min (2 gal/min).

A suggested method of meeting these requirements by using a bathroom radiator fitted with two lockshield valves is shown in [Fig. 5](#). Additional system information can be found in the Control Systems, pipework and Wiring Guide.

Page 9

---

## Sealed Systems

### Installation

The installation must comply with the requirements of BS 6798: 1987 and BS 5449: Pt 1. The British Gas publication "British Gas Specification for Domestic Wet Central Heating Systems" should also be consulted.

### Pressure Relief Valve

A non-adjustable spring-loaded pressure relief valve, preset to operate at 3 bar (45lb/in<sup>2</sup>) shall be used. It must comply with BS 6759: Pt 1. and include a manual testing device. It shall be positioned in the flow pipe either horizontally or vertically upwards and close to the boiler. No shut-off valves are to be placed between the boiler and the safety valve. The valve should be installed with a discharge pipe which permits the safe discharge of steam and hot water such that no hazard to persons or damage to electrical components is caused.

### Pressure Gauge

A pressure gauge incorporating a fill pressure indicator, covering the range 0 - 4 bar (60 lb/in<sup>2</sup>) shall be fitted to the system. It should be connected to the system, preferably at the same point as the expansion vessel. Its location should be visible from the filling point.

### Expansion Vessel

A diaphragm type expansion vessel to BS 4814: Pt 1. shall be fitted close to the inlet side of the pump. The connecting pipework should not be less than 15 mm. Pipework connecting the expansion vessel should not incorporate valves of any sort. Methods of supporting the vessel are supplied by the vessel manufacturer. The nitrogen or air charge pressure of the expansion vessel shall not be less than the hydrostatic head, (height of the top point of the system above the expansion vessel). To size the expansion vessel it is first necessary to calculate the volume of water in the system in litres. The following volumes may be used as a conservative guide to calculating the system volume.

Boiler Heat Exchanger: 2.1 litres

Small Bore Pipework: 1 litre per kW of system output

Micro Bore Pipework: 7 litres

Steel Panel Radiators: 8 litres per kW of system output

Low Water Capacity Rads: 2 litres per kW of system output

Hot Water Cylinder: 2 litres

If the system is extended, the expansion vessel volume may have to be increased unless provision has been made for extension. Where a vessel of the calculated size is not available, the next available larger size should be used.

The boiler flow temperature is controlled at approximately 82 °C. The vessel size can now be determined from the information in Table 1 where V = System volume in litres.

Vessel Charge Pressure (bar)	0.5	1.5
Initial System Pressure (bar)	1.0	1.0
Expansion Vessel Volume (litres)	V x 0.11	V x 0.087

Table 1.

## **Cylinder**

The hot water cylinder must be an indirect coil type or a direct cylinder fitted with an immersion calorifier suitable for operating at a gauge pressure of 0.3 bar (5 lbf/in<sup>2</sup>) in excess of safety valve setting. Single feed indirect cylinders are not suitable for sealed systems.

## **Method of Make-up**

Provision shall be made for replacing water loss from the system either:-

i) from a make-up vessel or tank mounted in a position higher than the top point of the system, and connected through a non-return valve to the system on the return side of the hot water cylinder or the return side of all heat emitters.

or

ii) where access to a make-up vessel would be difficult by using the mains top up method or a remote automatic pressurisation and make-up unit as shown in [Figs. 7](#).

## **Mains Connection**

There shall be no connection to the mains water supply or to the water storage tank which supplies domestic hot water even though a non-return valve, without the approval of the Local Water Authority.

## **Filling Point**

The system shall be fitted with a filling point at low level which incorporates a stop valve to BS 1010 and a double check valve of an accepted type to be fitted in this order from the system mains, see [Fig. 7](#).

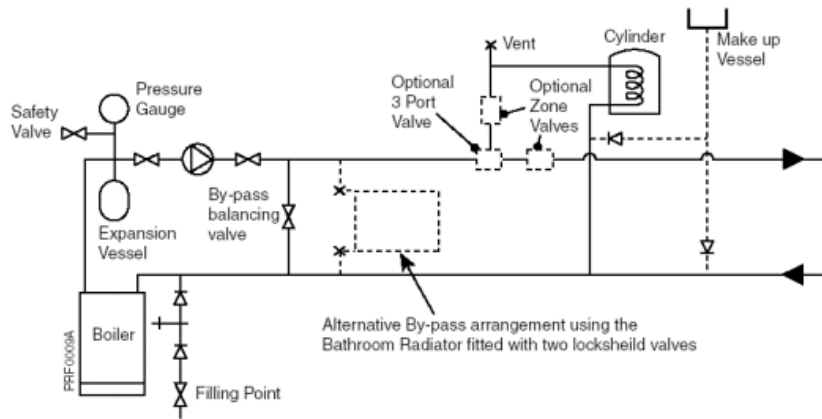
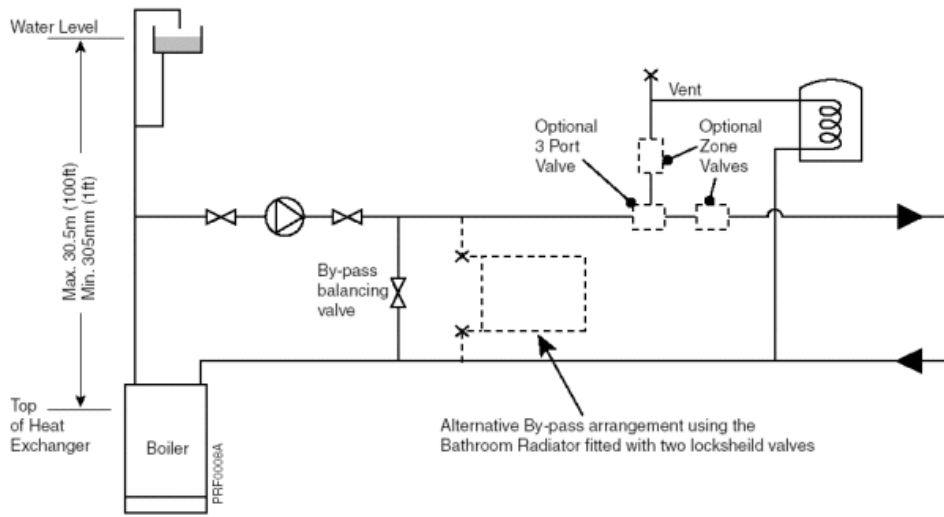

**Two methods of filling a sealed water system**

**Method 1  
Mains Topping-up Method**

Note: This method of filling a sealed system may only be used if acceptable to the Local Water Undertaking

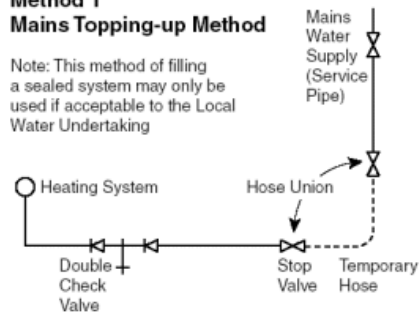

**Method 2  
Cistern Filling Method**

Note: Cistern to be supplied through a temporary connection from a service pipe or cold water distributing pipe

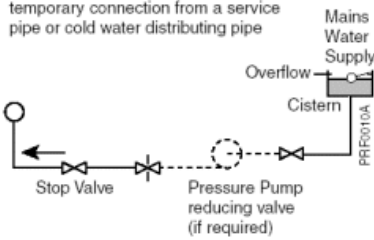

Fig. 5, 6, 7

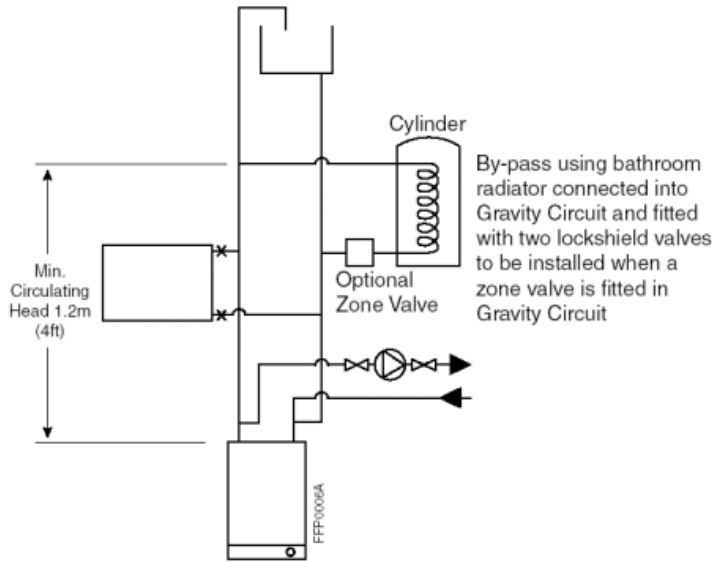
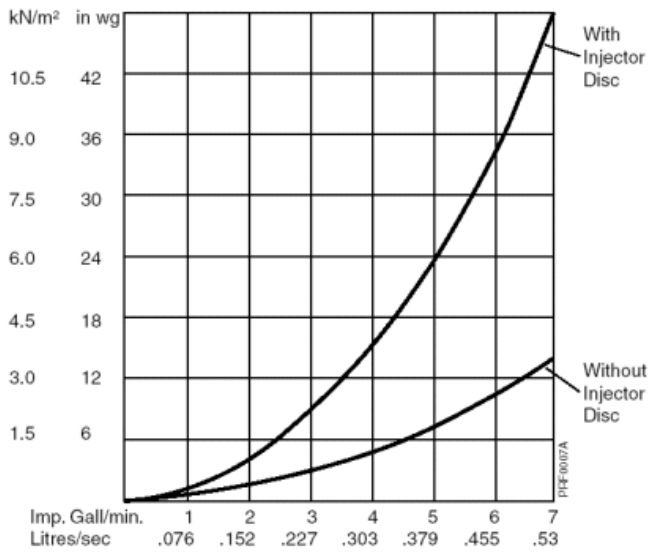

Fig. 8

### Circulation Pump Selection

The resistance through the heat exchanger when operating with a water flow rate producing an 11°C temperature rise at maximum boiler output are shown in the table. If other controls such as three position valves are used in the system, the resistance through them, quoted in their manufacturers literature must be taken into account. The pump may be fitted on either the flow or return and **MUST** be wired directly to the boiler terminal block. It must be fitted with two isolating valves which are positioned as close to the pump as possible. Closing of any valve must always leave the open vent unobstructed.

Model	Water Flow Rate		Boiler Resistance			
			with Disc		Without Disc	
	Litres/sec	gal/min	KN/m <sup>2</sup>	in wg	KN/m <sup>2</sup>	in wg
FF55	.38	5.0	5.7	23.0	1.75	7.0
FF75	.51	6.67	10.5	42.0	3.0	12.0



## 2. Installation

These instructions assume you have decided on where the boiler will be located and the type of flue system to be used.

### 2.1. Carefully unpack the boiler and flue.

Do not discard any packaging until all the items are accounted for.

## 2.2. Fixing Template

Place the template in proposed position ensuring it is level, the minimum side clearances are automatically allowed for.

### Rear Fluing:

Mark holes 'A', 'B', 'D', appropriate flue outlet hole and side of boiler reference lines 'C'.

### Side Fluing:

**Note:** Take into account the note within the boiler dimensions on [Page 7](#) regarding minimum and maximum clearances before marking flue hole.

Mark holes 'A', 'D' and side of boiler reference lines 'C'.

Mark flue outlet hole and holes 'B' using the appropriate lines on the template relative to the model of boiler you are installing.

## 2.3. Boiler Mounting Plate

Remove template and carefully cut flue outlet hole through wall. If necessary, make good around the hole to enable holes 'B' to be drilled.

**Note:** If using internal flue fitment kit refer to the instructions supplied with the kit.

Drill holes 'A' using a 7 mm drill

Drill holes 'B' and 'D' using a 5 mm drill

Using wall plugs, screws and washers (accessory pack A) attach boiler mounting plate to the wall. Ensure it is level and the correct way up, i.e. to provide the clearance at the rear of the boiler allowed for when marking out using the template.

Insert wall plugs into holes 'B' (accessory pack B) and holes 'D' (accessory pack D).

Insert flue sealing collar into wall and secure with screws provided, (accessory pack B). Make good the internal wall surface around flue sealing collar.

### *Boiler Pack contains:*

Boiler, Literature Pack, Auxiliary pack containing boiler mounting bracket, gas service cock and accessory packs.

### *Horizontal Flue System Pack contains:*

Air/Flue duct assembly - length as orderd, flue elbow extension, flue terminal, flue sealing collar, rope sealing ring and two side infill panels.

### *Vertical Flue System Pack contains:*

Air/Flue duct assembly, flue terminal, terminal cowl, vertical flue adaptor, accessory pack and two side infill panels.

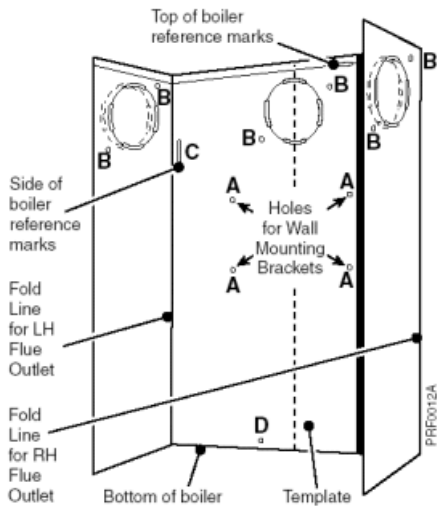

Fig. 9

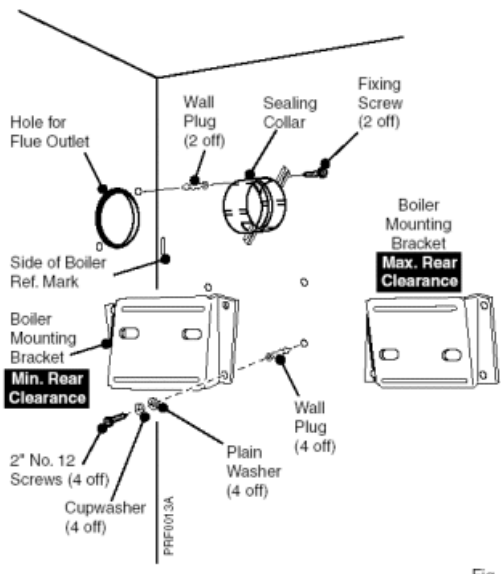

Fig. 10

Fig. 9, 10

Page 13

## 2.4. The Flue

### Side Flue

1. Measure from outside face of wall to the side of boiler casing reference line (dimension 'x').
2. Take air/flue duct assembly and measuring from the flanged end mark and cut the outer duct and inner flue duct to dimension 'x' plus 20 mm.

Ensure that both ducts are cut squarely.

**Note:** Cutting length remains the same for minimum or maximum clearance at the rear of the boiler.

### Rear Flue

1. Measure wall thickness (dimension 'y').
2. Take air/flue duct assembly and measuring from the flanged end mark and cut the outer duct and inner flue duct to dimension 'y' plus 48 mm, or dimension 'y' plus 58 mm if boiler mounting plate has been inverted.

Ensure that both ducts are cut squarely.

## 2.5. Air/Flue Duct Assembly

**Note:** During assembly the seam in the air duct should be so arranged that when installed, the seam in the duct will be uppermost.

1. Slide rope sealing ring on to air duct.

2. Engage the terminal on to the ends of the inner flue duct and press fully home.

**Note:** There is a silicone seal on the inner edge of the terminal. This is to prevent recirculation of flue products.

3. Engage four self tapping screws from accessory pack C into the pre-drilled holes in the terminal and screw fully home.

These will pierce the air duct and secure the terminal to it.

4. Protect the duct where it is likely to come into contact with mortar by using adhesive tape provided in accessory pack E.

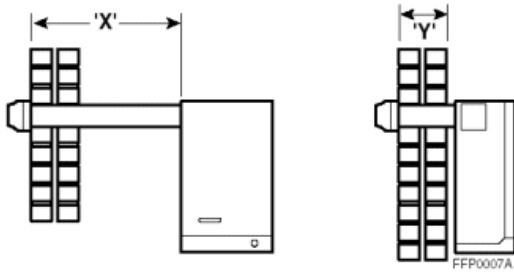

Fig. 11

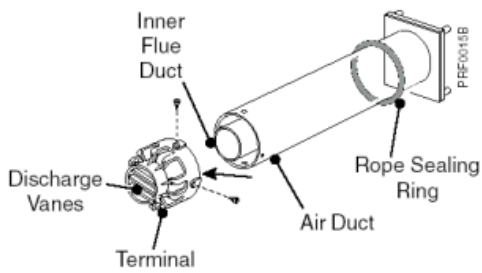

Fig. 12

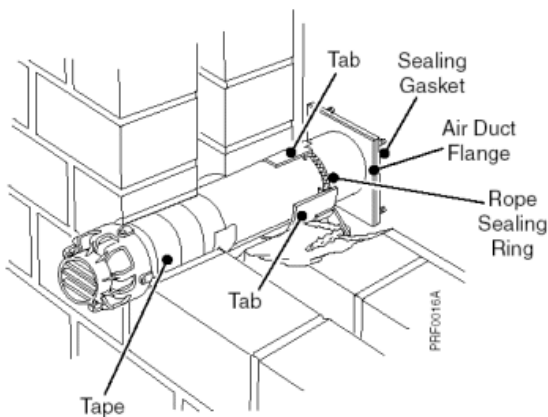

Fig. 11, 12, 13



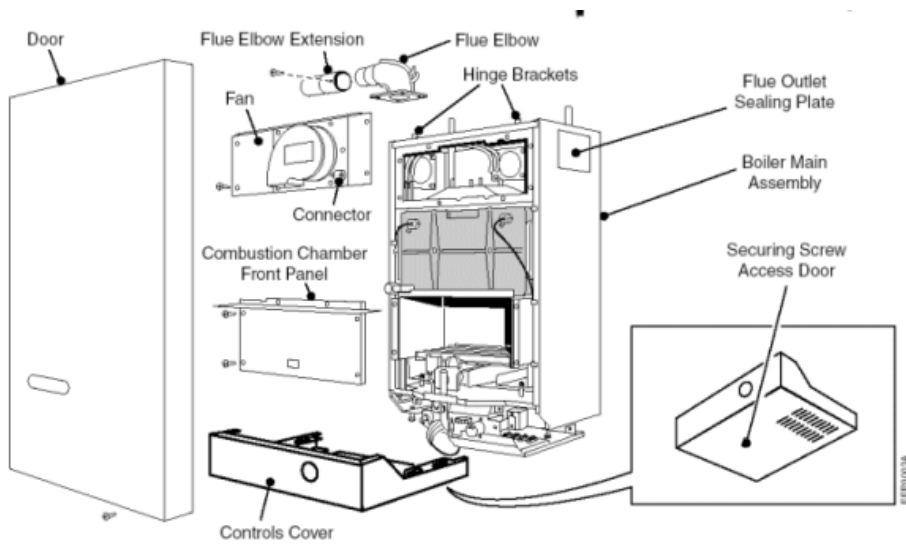

Fig. 14

5. Insert the assembly into the wall sliding the rope sealing ring along the air duct into the flue sealing collar. Bend the six tabs on the flue sealing collar inwards to retain the rope sealing ring. Ensure air duct flange studs do not obstruct lifting of boiler onto mounting bracket.

## 2.6. Prepare the Boiler

The controls cover should have been removed when unpacking the boiler, if not remove controls cover by opening the door covering the securing screw on the underside of the controls cover, see Fig. 14. Undo securing screw, pull controls cover forward 10 mm, lower to release from the four side fixings and pull forward clear of the thermostat knob.

Remove door by undoing the two lower fixing screws and lift door off the two upper hinge brackets.

Remove the screws securing the combustion chamber front panel and remove panel.

Disconnect the fan supply leads from the connector adjacent to the fan. Leaving in place the three screws identified with a red circle or adjacent 'F' mark in fan plate. Remove the remaining screws securing the fan mounting plate and remove the mounting plate complete with fan.

Disconnect the two flexible tubes from the flue elbow. Remove the four brass securing nuts and lift off the flue elbow, taking care not to damage the gasket.

**Note:** If side fluing, loosen the two brass securing nuts beneath the flue elbow outlet and remove the other two. Tilt the flange and withdraw the elbow.

The boiler is supplied with the flue outlet sealing plate removed on one side. If another flue outlet direction is required, remove the appropriate flue outlet sealing plate and transfer it to the left hand position.

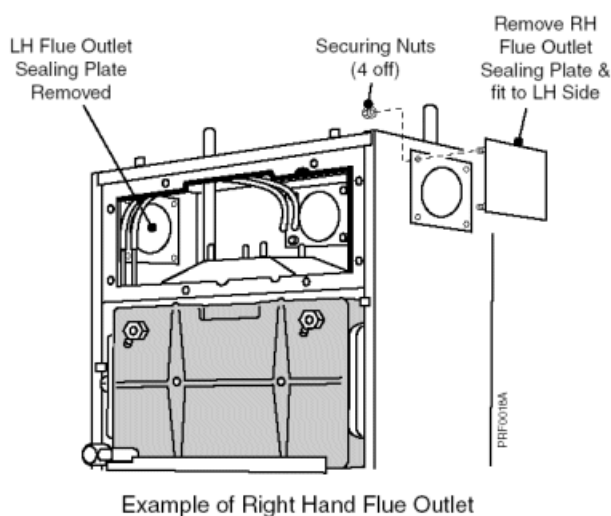

Fig. 15

## 2.7. Install the Boiler

Lift the boiler onto its mounting bracket. Locate the studs on the air duct flange through the boiler casing and secure using four wing nuts (accessory pack F).

Position boiler on its mounting bracket so that the sides of the boiler line up with the reference lines 'C' on the rear wall.

Undo the two screws securing the transportation foot and discard foot. Vertical alignment with rear wall can be corrected using the adjustment screws at the rear of the boiler.

Rotate the left hand adjustment screw to align one of the holes in the base plate with hole 'D' in the wall. Working through the hole in the leg, secure the base plate to the wall using the screw from accessory pack D.

Make good the wall surface around the flue terminal.

Fit optional terminal wall plate if required.

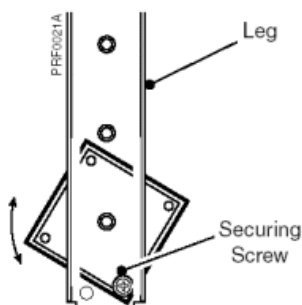
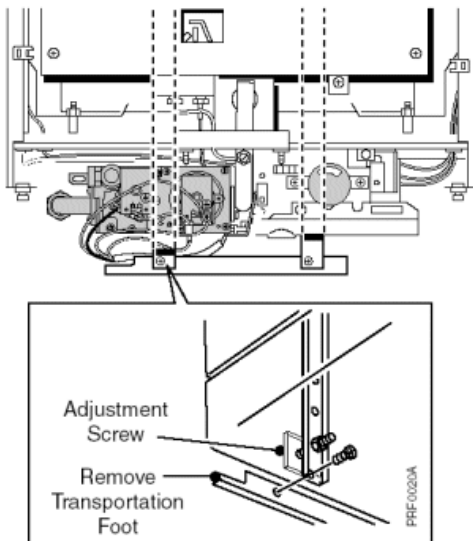
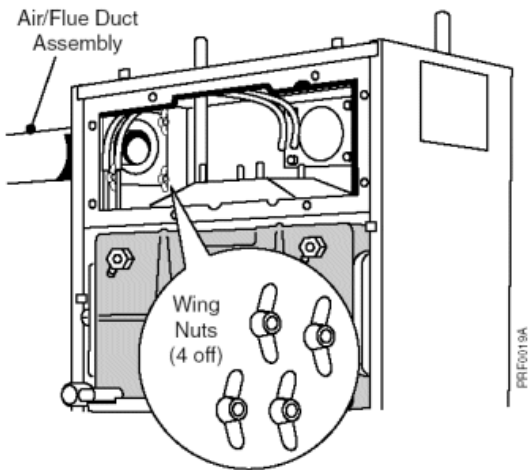

Fig. 16, 17, 18

When side fluing, slide the elbow extension onto the elbow and ensure that it is pushed on fully. Engage the screw from accessory pack 'C' into the pre-drilled hole in the elbow extension and screw fully home. The self tapping screw will pierce the elbow and secure the extension to the elbow.

When rear fluing, the elbow extension should be discarded.

Slide the flue elbow into the flue duct and locate the flange over the studs on the fluehood ensuring that the sealing gasket is in place.

Secure the elbow to fluehood using the four brass securing nuts.

Reconnect flexible tubes to elbow, **ensure they are not kinked**.

**Note:** Red tube connects the front aluminium tube in upper chamber to the lower connection on elbow, each being identified with a red ring.

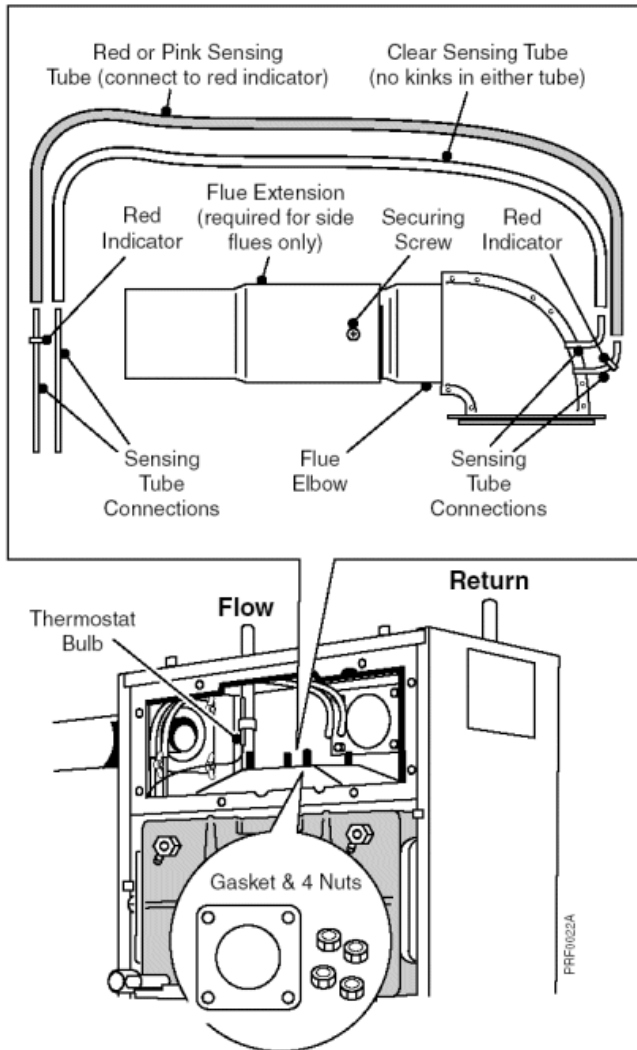

Fig. 19

Fig. 19

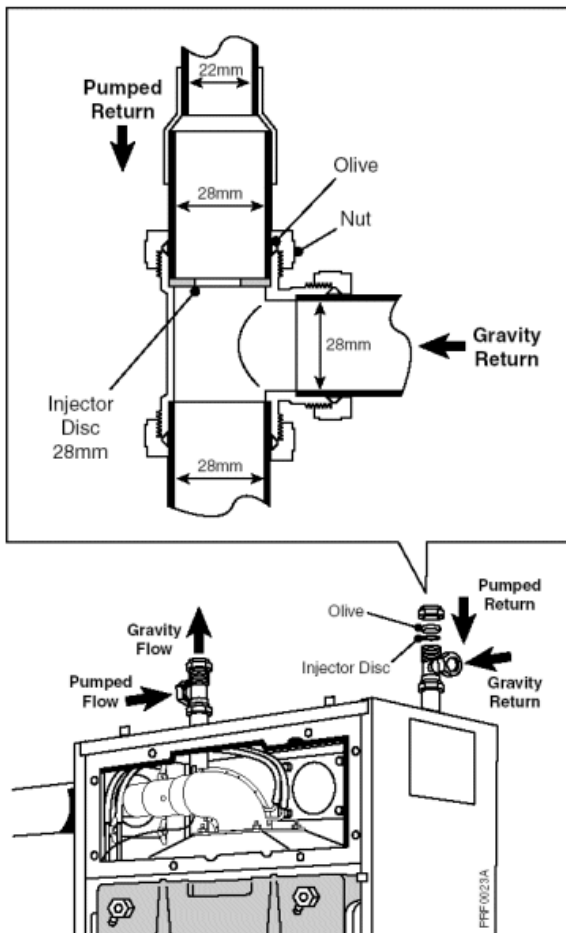

Fig. 20

## 2.8. Connect System Pipework

Connect system pipework to the boiler, compression fittings should be used. Ensure that the flow and return pipes do not rotate during tightening. The return pipe is marked with an indentation, this should face towards the front of the boiler.

If however capillary fittings are used it is essential to temporarily remove the thermostat bulb from the flow pipe before soldering.

A drain off tap should be installed close to the boiler if it is in a low point of the system.

On combined gravity hot water/pumped central heating installations the flow and return pipes for both the gravity hot water circuit and pumped central heating circuit must be connected to tees fitted directly to the flow and return pipes on the boiler.

The gravity circuit should be installed in 28 mm copper pipe.

The injector disc (accessory pack H) must be positioned in the pumped return branch of the tee and the pipes connected to the tees as illustrated in [Fig. 20](#).

Connect the gas supply pipe to the inlet of the gas cock. Ensure that the gas cock is in a position where it can be easily operated when the controls cover is removed.

Page 18

## 2.9. Set Overheat Thermostat Bulb Position

Ensure that the system change-over switch in the control box is correctly set e.g. for GRAVITY DHW system or FULLY PUMPED system. See [Fig. 1](#).

If the boiler is to be used on a GRAVITY DHW system the bulb of the overheat thermostat must be repositioned as shown in [Fig. 21](#). To do this loosen the plastic retaining screw and withdraw the thermostat bulb from its pocket.

Position the bulb as illustrated and secure it by finger tightening the plastic screw. Do not over-tighten.

## 2.10. Electrical Connections

The boiler and all external control circuit wiring must be supplied from the same single isolating switch or plug and socket, and should be fused at 3A.

Care must be taken to ensure that all wiring to the boiler is kept clear of sharp edges and hot surfaces.

The boiler terminal block which is situated in the control box is not designed to accept wiring from all the on site controls and therefore the installer will usually need to incorporate a suitable junction box. This may not be required if a Potterton Electronic Programmer is used as this incorporates a junction box. The principle of wiring is shown in [Fig. 22](#).

Remove control box securing screw and lower the control box to gain access to the boiler terminal block.

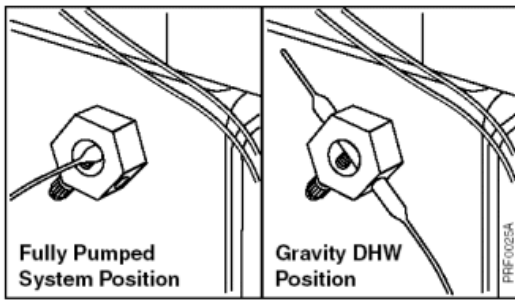

Fig. 21

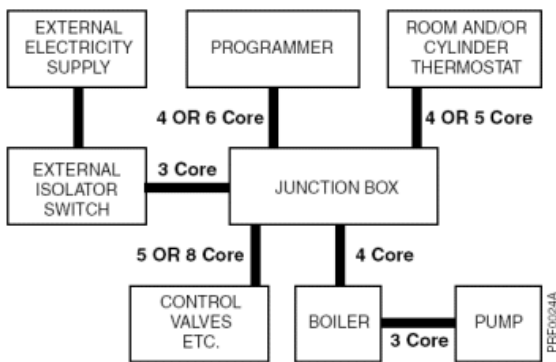

Fig. 22

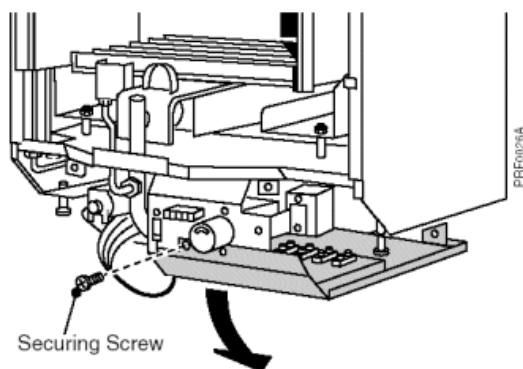

Fig. 23

Fig. 21, 22, 23

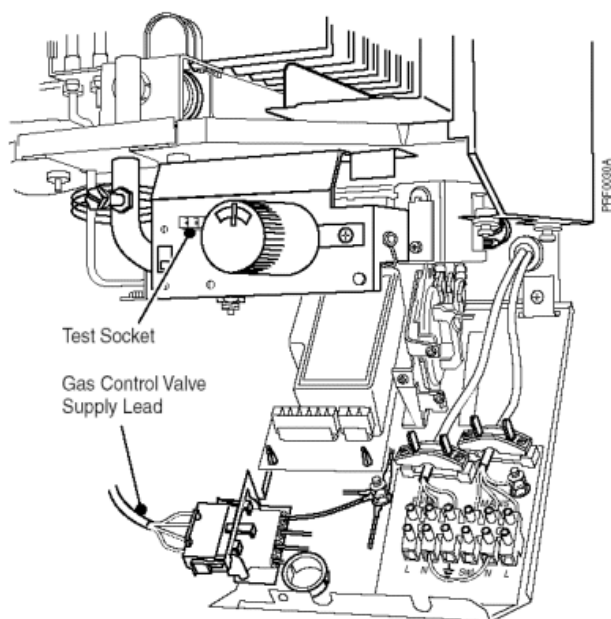

Fig. 24

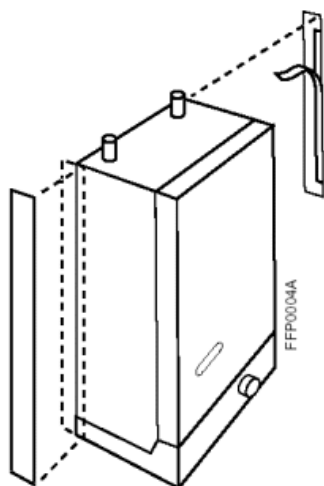

Fig. 25

Following the pump manufacturer's instructions connect the pump supply wires to terminals marked PUMP L, N,  $\perp$  on the boiler terminal block. Route the cable through the plastic bush in the rear of the control box as illustrated in [Fig. 24](#) and secure, using the cable clamp.

Route a four core cable through the plastic bush in the rear of the control box and the cable clamp as illustrated in [Fig. 24](#) and connect it to the boiler input terminals as follows:-

#### **Fully Pumped Systems.**

Permanent live to terminal marked MAINS 'L'.

Neutral to terminal marked MAINS 'N'.

Earth to terminal marked ' $\perp$ ' adjacent to cable clamp. See Note.

Switched live from external controls to terminal marked MAINS' SwL'.

If there are no external controls fitted connect the SwL terminal to permanent live in the junction box.

#### **Gravity Domestic Hot Water/Pumped Central Heating Systems.**

Switched live from external gravity domestic hot water control circuit to terminal marked MAINS 'SwL'.

Switched live from external pumped central heating control circuit to terminal marked MAINS 'L'.

Neutral to terminal marked MAINS 'N'.

Earth to terminal marked '  ', adjacent to cable clamp. See Note.

If there are no external controls fitted connect the SwL terminal to permanent live in the junction box.

**Note:** Ensure that the earth conductor is longer than the L, N & SwL from the point of anchorage, so that the current carrying conductors become taut before the earth conductor if cable is pulled out of the cable clamp.

When the wiring has been completed close the control box and replace the securing screw.

## 2.11. Fitting Side Infill Panels

If required, the gap between the casing sides and rear wall can be closed off using the infill panels supplied.

Ensure the casing surface is *fully clean and dry*. Remove the protective backing paper from the adhesive strip on the infill panel, carefully align and press into place, applying *firm even* pressure down the *full length* of contact area between panel and case. If conditions are near freezing, the boiler case should be warmed prior to application of the infill panel.

Page 20

---

## 3. Commissioning

### Important

The commissioning and boiler adjustment must only be carried out by a suitably qualified personnel. Potterton offer this service on a chargeable basis.

### Open Vented Systems

Remove the pump and flush out the system thoroughly with cold water. Refit the pump. Fill and vent the system. Examine for leaks.

### Sealed Systems

**Note:** The system can be filled using a sealed system filler pump with a break tank or by any other method approved by the Local Water Authority. Refer to '[The System](#)', Section 1.9, Page 9 in these instructions, also BS6798: 1987.

Remove pump and flush out the system thoroughly with cold water. Refit the pump. Fill and vent the system until the pressure gauge registers 1.5 bar (21.5 lb/in<sup>2</sup>). Examine for leaks.

**IMPORTANT:** The pressure relief valve is factory tested and does not need testing during the commissioning of the boiler. It must not be used to reduce system pressure as it may cause debris in the system to foul the valve.

### All Systems

Refit the fan assembly and reconnect the fan supply leads, (polarity of the fan leads is not important).

The whole of the gas installation including the meter should be inspected and tested for soundness and purged in accordance with the recommendations of BS6891.

Test pilot unions for gas soundness as follows: Turn boiler thermostat to the '0' position.

Unplug the gas control valve supply lead from the control box and plug it into the test socket adjacent to the boiler thermostat knob, see [Fig. 24](#).

Turn on gas at the gas service cock.

Ensure that the time control if fitted is in an ON condition, and that the room and/or cylinder thermostats where fitted are set to high temperatures.

Switch on the external electricity supply to the boiler.

### Important

When checking for gas soundness open all windows and doors in the room.

Extinguish all naked lights, cigarettes, pipes, etc.

Gas will flow to the pilot only. It will not be ignited as the ignition system is de-energised.

Using a leak detection fluid, check pilot unions for gas soundness.

Turn off the external electricity supply and gas service cock.

Remove gas control valve plug from the test socket and refit the plug into the socket on the left hand side of the control box see [Fig. 24](#).

Refit the combustion chamber front panel.

Fit the case door into position by lifting it onto the top hinge brackets and secure it with the lower two fixing screws. ENSURE THAT A GOOD SEAL IS OBTAINED

Remove the temporary label from the front of the casing, having checked compliance with the information it contains.

### First Lighting

**Warning:** Before lighting the boiler, ensure that the CASE DOOR HAS BEEN CORRECTLY FITTED and that the sealing strip fitted to the case door is forming a tight seal with the main boiler casing. Before proceeding to light the boiler, check that the external electricity supply to the boiler is switched off and that the boiler thermostat is in the '0' position.

Turn on the gas service cock, ensure that the pump and radiator isolating valves are open, ensure that the time control, if fitted is in an on condition, and that the room and/or cylinder thermostats, where fitted are set to high temperatures.

Switch on the external electricity supply to the boiler.

In the event of an electrical fault after installation of the appliance, preliminary electrical system checks must be carried out i.e.:-

- A. Earth Continuity
- B. Short Circuit
- C. Polarity
- D. Resistance to Earth

Page 21

---

Refer to Fault Finding Chart [Fig. 31](#)

Turn the boiler thermostat on and to a high setting and after a period of time the main burner will light, this can be observed through the sight glass in the front cover of the boiler. The time period can vary upwards of 45 seconds, depending on the amount of air in the pipework.

Test for gas soundness around the boiler components using leak detection fluid.

Turn the boiler thermostat to '0'. **Note:** There could be a delay in lighting if the control knob is switched on and off and then on again rapidly.

### Setting and Checking of Controls

With the controls cover removed.

Fit a pressure gauge to the pressure test nipple in burner supply pipe. See [Fig. 1](#).

Turn on the boiler thermostat and ensure that the main burner is alight. Check that the burner pressure is in accordance with values stated on the Data Badge.

The gas valve is factory set, but if adjustment is required follow [section 4.8](#).

With the burner set to its correct pressure, the firing rate given in [Technical Data](#) should also be obtained and this should be checked by meter reading at least 10 minutes after the main burner has been lit.

Shut down the boiler, remove the pressure gauge and refit the screw in the test nipple ensuring that a tight seal is made.

Refit the controls cover.

Relight the boiler and heat the system to maximum. Check for water leaks, turn the boiler off, drain the system whilst hot.

Refill the system and on sealed systems adjust to the correct cold fill pressure. Set the pressure gauge pointer to the system design pressure.

If a by-pass circuit is fitted the by-pass valve should be adjusted with the boiler operating under minimum load conditions to maintain sufficient water flow through the boiler to ensure that the overheat thermostat does not operate under normal operating conditions.



## Pilot Burner

The pilot is pre-set and no adjustment is required. The pilot flame envelope should cover the electrode tip and spark earthing strip, see [Fig. 30](#). If the pilot flame is not as illustrated, remove and clean the pilot as described in the Servicing Instructions Section 4.3, [Pilot Burner](#), Page 26.

## Boiler Thermostat

At its minimum and maximum settings, the thermostat should control the water flow temperature at approximately 55 °C - 82 °C (130 °F - 180 °F).

The thermostat has been calibrated by the makers and no attempt should be made to re-calibrate it on site. Turn the thermostat to the '0' position and check that the main burner shuts down.

## Gravity Hot Water/Pump Over-Run Thermostat

The function of this thermostat is determined by the position in which the GRAVITY/FULLY PUMPED SYSTEM selection switch is set. The thermostat is preset and no adjustment is possible.

On the FULLY PUMPED switch position it will operate as a pump over-run thermostat and will keep the pump running after the boiler has shut down, as long as the water temperature within the boiler is above approximately 80 °C.

On the GRAVITY switch position it will operate in series with the boiler thermostat when only the gravity domestic hot water circuit is in operation.

It will over-ride the boiler thermostat when the water temperature within the boiler is above 80 °C.

## Overheat Thermostat

The overheat thermostat is pre-set and no adjustment is possible. It will require manually resetting if an overheat condition occurs. Access to the reset button is through a hole in the underside of the controls cover, see [Fig. 1](#).

## Other Boiler Controls

All boiler mounted controls are designed so that if any fault should occur they will fail safe. No further setting or checking is necessary.

Page 22

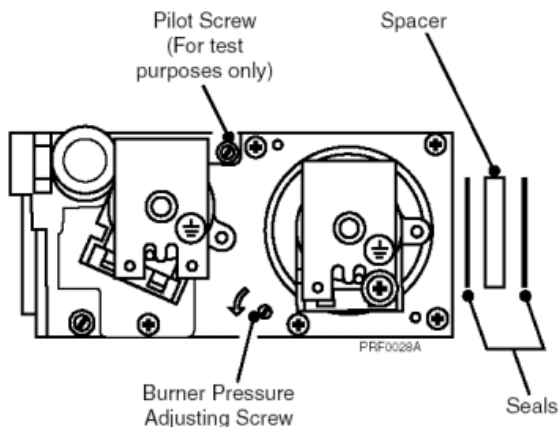

Fig. 26

## External Controls

Check that any other external control connected in the system, such as clocks and thermostats, control the boiler as required.

## User's Instructions

A User's Instructions leaflet is provided with this boiler but the householder must have the operation of the boiler and system explained by the Installer.

The householder must also be advised of the importance of annual servicing and of the precautions necessary to prevent damage to the system and building, in the event of the system remaining out of commission in frost conditions.

Finally, complete the Benchmark Log Book and hand over all instructions.

Page 23

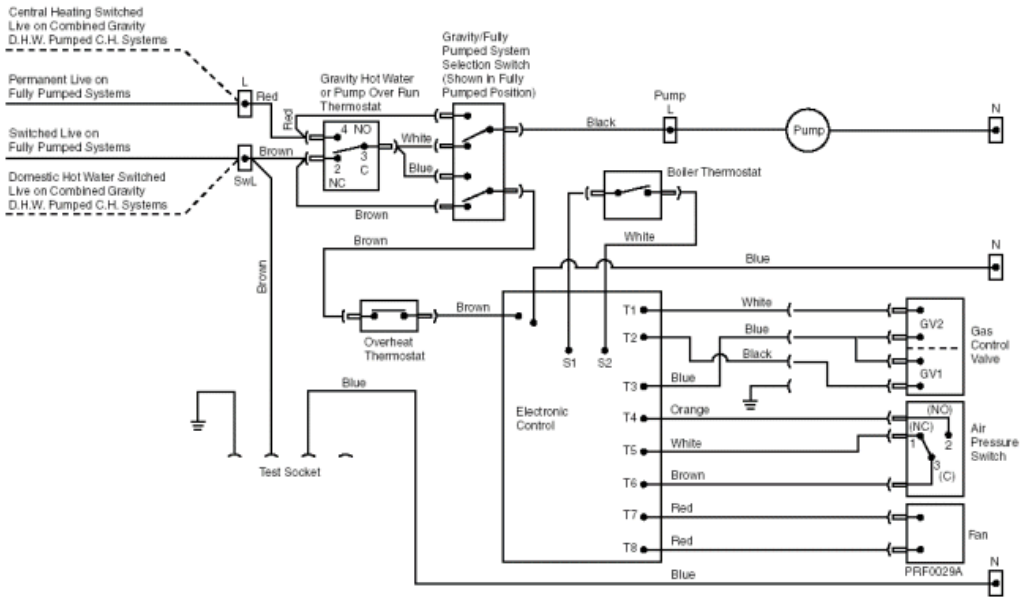

Fig. 27

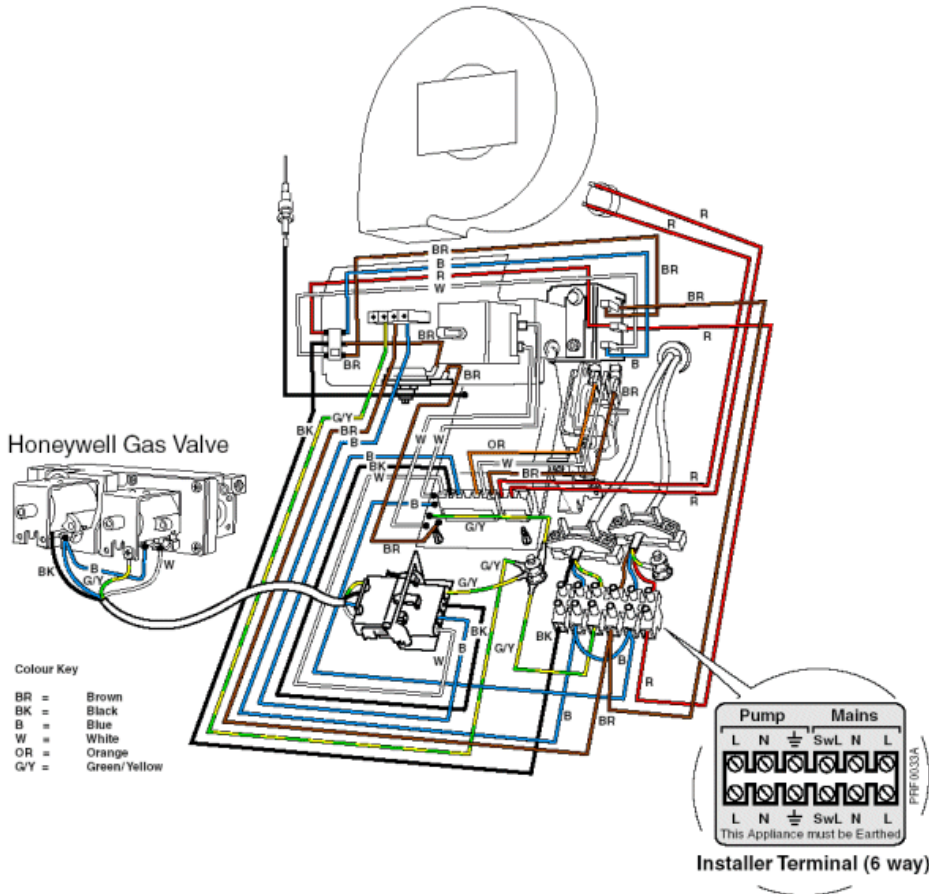

Fig. 28

Fig. 27, 28

#### 4. To Service the Boiler & Component Replacement

Remember to fill in the Benchmark Log Book. Regular skilled servicing and cleaning of the appliance is essential to ensure continued safe and efficient operation. The frequency of cleaning will depend upon the particular installation conditions, and the use to which the appliance is put, but in general, once per year should be adequate.

It is the law that all gas appliances are installed and serviced by competent persons as stated in Gas Safety (installation and Use) Regulations 1998.

For [Health and Safety information](#) see page 4.

Electrical installation and servicing should be carried out by a competent person in accordance with the I.E.E. Wiring Regulations.

Servicing is best arranged by a contract placed with Potterton and further details are available from Service Enquires - see back page.

The boiler DATA PLATE and WIRING DIAGRAM are attached to the inside of the controls cover. The boiler CODE NUMBER which should be quoted when ordering spares or requesting information is on the front of the control box. See [Fig. 1](#).

All parts likely to require servicing are readily accessible. By removing the cover from the boiler controls and removing the front door from the boiler, most components are exposed. Remove the front of the combustion chamber to gain access to the main and pilot burner and the ignition electrode. Removal of the fan and its mounting plate exposes the flue system, i.e. the flue elbow and fluehood. These must be removed to gain access to the flueways in the heat exchanger for cleaning.

The following notes apply to the boiler and its controls but it should be remembered that attention must also be paid to the heating circuit itself including radiator valves, thermostats, the time control and the expansion and feed water system. It is advisable to clean the boiler immediately after the end of the heating season.

In all cases prior to servicing, light up the boiler and check that the pilot and main burners have a clean, even flame and that the gas rate and main burner pressure are correctly set. If the pilot flame is satisfactory, no further servicing of the pilot burner is necessary and the information given in '[4.3. Pilot Burner](#)' can be ignored.

**Warning:** Before the start of any servicing work, switch off at the external electricity supply by disconnecting the supply plug at the socket or switching off the external isolating switch. Turn off the gas service cock.

**Note:** After completing any servicing or replacement of components check for gas soundness and carry out functional checks.

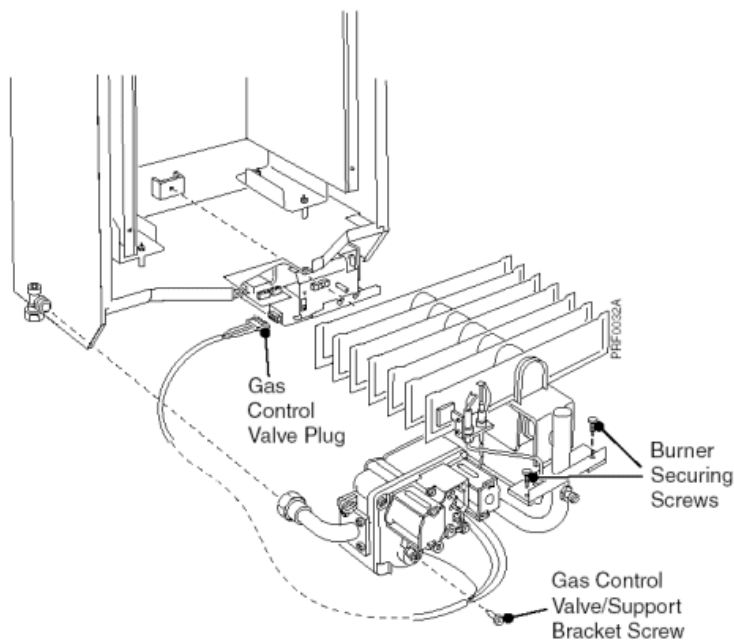

Fig. 29

Page 25

#### 4.1 Preparing the Boiler for Servicing

**Note:** Boilers with side or rear flues have a flue elbow fitted to the fluehood.

The elbow is replaced by an adapter on vertically flued boilers.

A. Remove controls cover by opening the door covering the securing screw on the underside of the controls cover, see [Fig.14](#). Undo securing screw, pull controls cover forward 10 mm, lower it to release it from its four side fixings and pull forward clear of the thermostat knob.

B. Remove door by undoing the lower fixing screws and lift door off the two upper hinge brackets.

C. Remove screws securing the combustion chamber front panel and remove panel.

D. Disconnect the fan supply leads from the connector adjacent to the fan.

E. Remove the screws securing the fan mounting plate leaving in place the three screws identified with a red circle or adjacent 'F' mark in fan plate. Remove mounting plate complete with fan.

F. Disconnect the two flexible tubes from the flue elbow or adapter.

G. Loosen the two brass securing nuts beneath the flue elbow outlet and remove the other two. Tilt the flange and withdraw the elbow. Take care not to damage the gasket. On vertically flued boilers remove the four brass nuts and slide the vertical flue adapter up into the flue duct.

H. Unscrew the four nuts and lift off the fluehood taking care not to damage the rope seal. Lower and lift out vertical flue adapter.

I. Undo the union on the gas service cock outlet.

J. Unplug the electrical supply leads for the gas control valve from the control box. See [Fig. 29](#).

K. Remove the screw securing the gas control valve to its support bracket. See [Fig. 29](#).

L. Disconnect electrode lead from electrode.

M. Remove two screws securing the burner assembly to the bottom of the boiler case and lift out the burner and gas control assembly.

#### 4.2 Heat Exchanger

A. Working from above and below the heat exchanger use a suitable brush and remove all deposits from between the fins. Slide vertical flue adapter into flue duct.

B. Refit the fluehood, ensuring that the rope seal is undamaged and that a GOOD SEAL is made with the heat exchanger. Fully tighten the four nuts.

C. Slide the flue elbow into the flue duct or lower flue adapter and secure to the fluehood using four nuts. Ensure that the gasket between the fluehood and elbow or adapter is undamaged and a good seal is obtained.

D. Reconnect flexible tubes to elbow or adapter.

**Note:** Red tube connects the front aluminium tube in the upper chamber to the lower connection on elbow or adapter, each being identified with a red ring.

#### 4.3 Pilot Burner

The following operations are only necessary if the pilot flame is distorted or the wrong size, i.e. too small.

A. Check that the pilot screw [Fig. 26](#), is fully open (turn anti-clockwise).

B. Unscrew the aluminium pilot tube from the pilot assembly. Take care not to damage the electrode.

C. Unscrew the two hexagonal head screws securing the pilot (and shield on 80) to the main burner and remove the pilot assembly, be careful that the pilot injector does not fall out during this operation.

D. Lightly brush the pilot and its shield to remove any deposits. Remove the pilot injector and clean its orifice or replace.

**Note:** Do not use a wire brush or pin to clean injector.

E. Gently clean any deposits from the electrode.

F. Refit the pilot injector to the pilot burner and assemble the pilot to the aluminium tube.

G. Secure the pilot assembly to the main burner using two hexagonal screws.

H. Fully tighten the union nut connecting the aluminium tube to the pilot. Check for gas soundness at this joint by following the procedure described in the [commissioning](#) section of these instructions, Page 21.

I. Ensure that the spark gap is as illustrated in [Fig. 30](#).

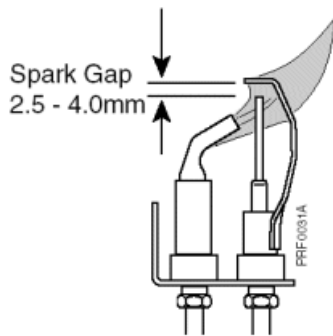

Fig. 30

### Pilot Filter

The pilot burner is protected from blockage by a pilot filter situated within the gas control valve. The filter is large and designed to last the life of the gas control valve under normal operating conditions, it is therefore unlikely to need replacing. However in the event of pilot filter blockage being suspected the complete control valve should be replaced.

### 4.4 Combustion Chamber Insulation

A. Check the combustion chamber insulation for damage. If damaged replace as described under replacement.

### 4.5 Main Burner

A. Lightly brush any deposits from the top of each blade and ensure there is no fluff in the entry of the burner venturi. If on re-assembly the burner flame picture is incorrect or the correct gas rate or burner pressure cannot be obtained, remove the burner and gas control assembly and thoroughly clean the burner. Clean or replace the injector. In the event of the above procedures not rectifying the flame appearance, disconnect the burner from the gas control valve at the flanged connection and replace the burner and injector.

B. Refit the burner and gas control valve assembly into the boiler, ensuring that the locating pin on the rear of burner engages correctly into the rear support bracket. Make sure that the sealing gasket is in place and undamaged between the burner flange and the case. Secure the assembly with two screws.

C. Refit the screw securing the gas control valve to the support bracket.

D. Reconnect electrode lead to electrode.

E. Plug gas control valve supply leads into control box.

F. Reconnect gas supply at gas service cock and turn on gas.

G. Refit the combustion chamber front panel.

### 4.6 Fan

A. Carefully clean any deposits from around the fan motor and its supports.

B. Very gently clean the fan impellor taking care not to damage the aluminium impellor or dislodge its balance weights.

C. Replace the fan and its mounting plate.

Ensure that the securing screws are fully tightened as an air tight seal must be obtained between the fan assembly and the main boiler casing.

D. Reconnect the fan supply leads (polarity is not important).

### 4.7 Case Seal

Check the case door seal. Replace if damaged. The seal is simply pressed into the channel around the door.

### Re-commission

Follow the full commissioning procedure as detailed in the [Commissioning](#) section of these instructions page 21.

### Other Boiler Mounted Units

No further servicing is required on any other boiler mounted units. Repair is by replacement.

### Fault Finding

Refer to [Fault Finding Chart](#) (page 32) and [Wiring Diagrams](#) (page 24).

## Removal/Replacement of Boiler Mounted Units

### 4.8 Gas Control Valve

This operation is most easily carried out by first removing the burner and gas control valve assembly as follows:-

1. Switch off the external electricity supply by disconnecting the plug at the socket or switching off the external isolating switch.
2. Remove controls cover, case door and combustion chamber front panel as described in 4.1. '[Preparing the Boiler for Servicing](#)', operations A, B and C.
3. Remove the burner and gas control assembly as described in 4.1. '[Preparing the Boiler for Servicing](#)', operations I, J, K, L and M.
4. Disconnect the electrical supply wires from the gas control valve noting their position. See [Figs. 27 & 28](#).
5. Unscrew the union connecting the pilot supply pipe to the gas control valve.
6. Separate the gas control valve from the flanges at the inlet and outlet ports by removing the securing screws.

**Note:** A spacer is used between the valve outlet and the burner flange, requiring the use of two seals at this point. See [Fig. 26](#).

7. Use new seals on re-assembly.
8. Replacement is the reverse of removal.
9. Check that the burner pressure is in accordance with the information on the data badge. If adjustment is required, turn the pressure adjusting screw anticlockwise to increase pressure or clockwise to decrease.

### 4.9 Fan

1. Switch off the external electricity supply by disconnecting the plug at the socket or switching off the external isolating switch.
2. Remove controls cover and case door as described in 4.1. '[Preparing the Boiler for Servicing](#)', operations A and B.
3. Disconnect the fan supply leads from the connector adjacent to the fan.
4. Remove the screws securing the fan to the mounting plate and remove fan.
5. Replacement is the reverse of removal.
6. Follow the full commissioning procedure as detailed in the [Commissioning](#) section of these instructions on page 21.

### 4.10 Main Burner

1. Switch off the external electricity supply by disconnecting the plug at the socket or switching off the external isolating switch.
2. Remove controls cover, case door and combustion chamber front panel as described in 4.1. '[Preparing the Boiler for Servicing](#)', operations A, B and C.
3. Remove the burner and gas control assembly as described in 4.1. '[Preparing the Boiler for Servicing](#)', operations I, J, K, L and M.
4. Unscrew the union nuts connecting the pilot supply pipe to the pilot and gas control valve. Take care not to damage the electrode and be careful that the pilot injector does not fall out during this operation.

Remove sealing grommet and withdraw the pilot tube through the hole in the burner mounting flange.

5. Separate the burner from the gas control valve at the flanged connection by removing the four securing screws.

**Note:** A spacer is used between the valve outlet and the burner flange, requiring the use of two seals at this point. See [Fig. 26](#).

6. Unscrew the pilot, main burner injector and pressure test nipple from the burner.
7. Use new sealing gaskets on re-assembly.
8. Replacement is the reverse of removal.
9. Follow the full commissioning procedure as detailed in the [Commissioning](#) section of these instructions on page 21.

### 4.11 Pilot/Ignition Electrode

1. Switch off the external electricity supply by disconnecting the plug at the socket or switching off the external isolating switch.
2. Remove controls cover, case door and combustion chamber front panel as described in 4.1. '[Preparing the Boiler for Servicing](#)', operations A, B and C.
3. Disconnect the electrode lead from electrode.
4. Unscrew the aluminium pilot tube from the pilot assembly. Take care not to damage the electrode.

Page 28

---

5. Unscrew the two hexagonal head screws securing the pilot (and shield on 80) to the main burner and remove the pilot assembly, be careful that the pilot injector does not fall out during this operation. Unscrew electrode retaining nut and withdraw the electrode.
6. Replacement is the reverse of removal. On re-assembly ensure that the spark gap is as illustrated in [Fig. 30](#).
7. Follow the full commissioning procedure as detailed in the [Commissioning](#) section of these instruction on page 21.

#### **4.12 Combustion Chamber Insulation**

1. Switch off the external electricity supply by disconnecting the plug at the socket or switching off the external isolating switch.
2. Remove main burner as described in 4.1 '[Preparing the Boiler for Servicing](#)', operations A, B, C, I, J, K, L, M.
3. Bend back retaining tabs and replace insulation. It is necessary to first remove the side insulation when replacing the rear.
4. Replacement is the reverse of removal.
5. Follow the full commissioning procedure as detailed in the [Commissioning](#) section of these instructions on page 21.

#### **4.13 Fuse, 4.14 Electronic Control, 4.15 Pressure Switch, 4.16 Overheat Thermostat, 4.17 Boiler Thermostat, 4.18 Gravity HW/Pump Overrun Thermostat, 4.19 Heat Exchanger Pipe Seal**

**Note:** 4.13, 4.14 & 4.15 are on this page. 4.16, 4.17, 4.18 & 4.19 are on page 30.

The following initial operations 1-3 are necessary to remove and replace any of the above items.

1. Switch off the external electricity supply by disconnecting the plug at the socket or switching off the external isolating switch.
2. Remove controls cover by opening the door covering the securing screw on the underside of the controls cover see [Fig. 14](#). Undo securing screw, pull controls cover forward 10 mm, lower it to release it from its four side fixings and pull forward clear of the thermostat knob.
3. Remove control box securing screw and lower control box.

#### **4.13 Fuse 1 amp**

4. The fuse is located on the electronic control and can be replaced by lifting it from its holder.
5. Replacement is the reverse of removal. Refer to [Figs. 27 & 28](#).

#### **4.14 Electronic Control**

4. Disconnect six way plug, two way plug and electrode lead from the electronic control. Refer to [Figs. 27 & 28](#).

Disconnect the flying leads of the electronic control as follows:-

- white wire from terminal C (3) of the control thermostat
- white wire from terminal NC (2) of the control thermostat
- brown wire from overheat thermostat
- blue wire from boiler terminal block connection N
- green/yellow wire from earth post

5. Release the control by lifting it from the four retaining lugs.
6. Remove electronic control.
7. Replacement is the reverse of removal.
8. Follow the full commissioning procedure as detailed in the [Commissioning](#) section of these instructions on page 21.

#### **4.15 Pressure Switch**

4. Remove the screw securing the pressure switch to the bracket in the control box. Lift pressure switch from bracket.



5. Disconnect the two plastic tubes.

**Note:** the red tube is connected to the pressure switch connection identified with a redring, or adjacent red spot.

6. Disconnect the three electrical leads, white wire from terminal No. 1 or NC, orange from terminal No. 2 or NO and brown from terminal No. 3 or C. Refer to [Figs 27 & 28](#).

7. Replacement is the reverse of removal. Ensure that the plastic tubes are not kinked on re-assembly.

8. Follow the full commissioning procedure as detailed in the [Commissioning](#) section of these instructions on page 21.

Page 29

---

#### **4.16 Overheat Thermostat**

4. Remove door by undoing the two lower fixing screws and lifting door off the two upper hinge brackets.

5. Disconnect the two push on electrical connections from the overheat thermostat terminals.

6. Remove the nut securing the overheat thermostat to its mounting bracket.

7. Noting the route taken by the capillary, loosen the plastic screw retaining the thermostat bulb and withdraw bulb from its pocket. Remove the split grommet in the base of the boiler, feed the thermostat capillary and bulb through the hole.

8. Replacement is the reverse of removal. Ensure the rubber grommet in the base of the boiler makes a good seal around the capillary. Ensure that the capillary is secure in the clips provided. Refer to [Fig. 21](#).

9. Follow the full commissioning procedure as detailed in the [Commissioning](#) section of these instructions on page 21.

#### **4.17 Boiler Thermostat**

4. Remove door by undoing the two lower fixing screws and lifting door off the two upper hinge brackets.

5. Disconnect the fan supply leads from the connector adjacent to the fan.

6. Remove the screws securing the fan mounting plate, leaving in place the three screws circled red (or with adjacent 'F' mark), and remove the plate complete with fan.

7. Disconnect the electrical connections as follows:-

White from terminal C(3). White from NC(2) - Refer to [Figs. 27 & 28](#).

8. Pull off the outer thermostat knob.

9. Remove inner thermostat post by undoing the two securing screws.

10. Remove the nut securing the thermostat to the control box.

11. If the boiler is fitted with a left hand flue, remove the flue elbow as described in Section 4.1, [Preparing the Boiler for Servicing](#), operations F & G.

12. Remove the clip securing the thermostat bulb to the flow pipe.

13. Remove the split grommet in the base of the boiler and the split grommet in the fan chamber. Feed the capillary and bulb through the holes.

14. Replacement is the reverse of removal. The bulb of the new thermostat should be coated with heat conducting paste. Ensure the rubber grommets in the base of the boiler and the fan chamber make a good seal around the capillary.

15. Ensure that the capillary is secure in the clips provided.

Follow the full commissioning procedure as detailed in the [Commissioning](#) section of these instructions on page 21.

#### **4.18 Gravity Hot Water/Pump Overrun Thermostat**

4. Remove door by undoing the lower fixing screws and lifting door off the two upper hinge brackets.

5. Disconnect the electrical connections as follows:

2 red wires from terminal NO (4)

2 brown wires from terminal NC (2)

1 white and 1 blue wire from terminal C (3)

(These are the larger numbers marked on the thermostat, ignore the smaller numbers).

6. Remove the screws securing the thermostat to the control box.



7. Remove the split pin retaining the thermostat bulb in the pocket and withdraw the bulb.
8. Remove the split grommet in the base of the boiler. Feed the capillary and bulb through the hole.
9. Replacement is the reverse of removal. The bulb of the new thermostat should be coated with heat conducting paste. Ensure the rubber grommet makes a good seal around the capillary.
10. Ensure that the capillary is secure in the clips provided. Follow the full commissioning procedure as detailed in the [Commissioning](#) section of these instructions on page 21.

#### 4.19 Heat Exchanger Pipe Seal

4. Remove door and fan mounting plate as described in [4.17](#), sections 4, 5 & 6.
5. Loosen pipe nut, lift pipe and remove seal.
6. The return pipe is marked with an indentation, this should face towards the front of the boiler.

Page 30

Intentional Blank

Page 31

### 5. Fault Finding Guide

#### Fault Finding Chart

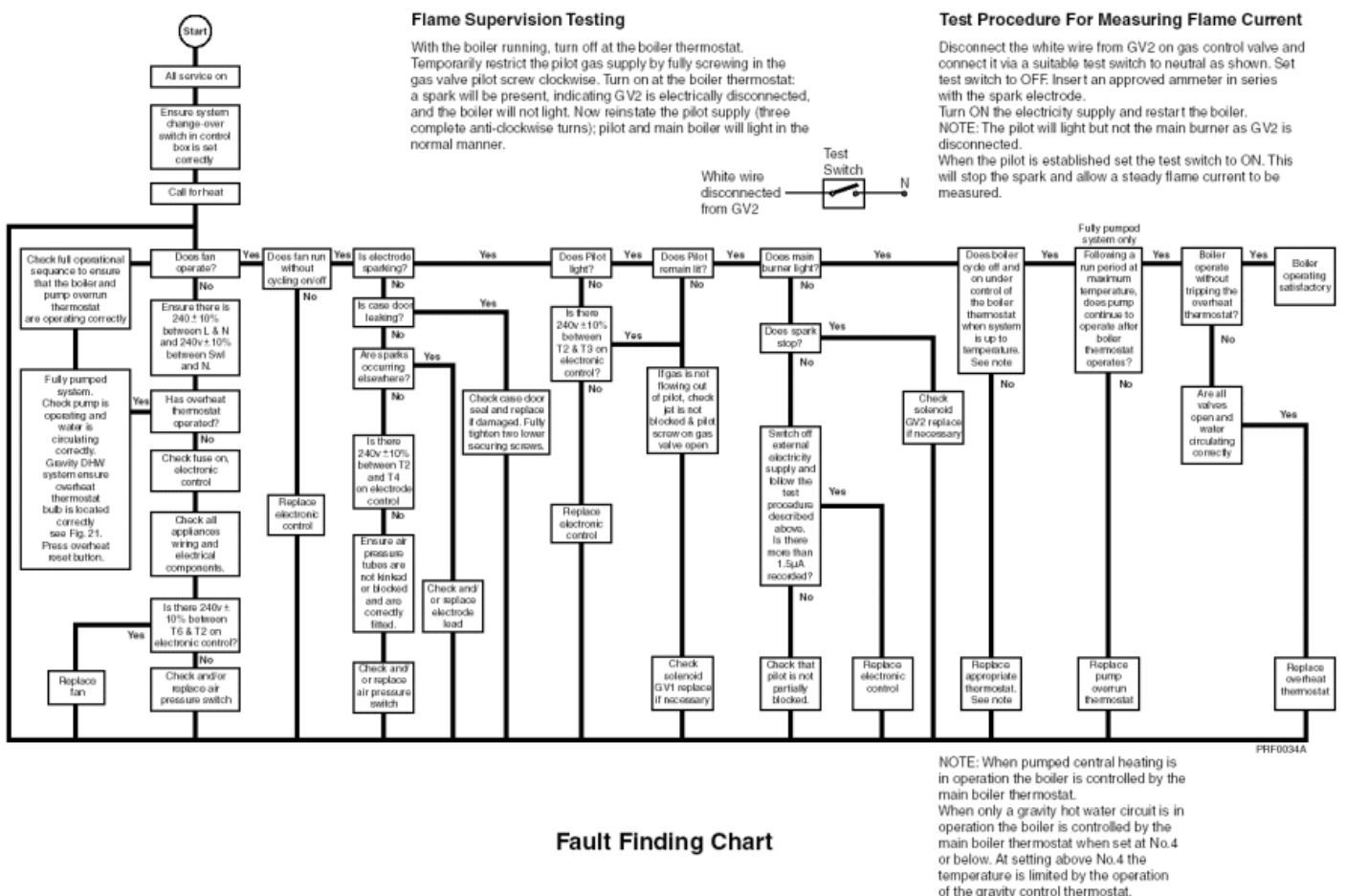

Fig. 31

Page 32

### 6. Optional Extras

## Optional Extras

**Internal Fitment Kit**, which is suitable for a maximum wall thickness of 510 mm and where access to the outside wall is impracticable.

**Pump Cover Kits**, located on top of the boiler and designed to conceal the pump, and/or any motorised valves installed above the boiler. **Note:** The pump cannot be fitted above the boiler if using a vertical flue kit.

**Terminal Wall Plate**, where necessary can be fitted to the outside wall face to improve the appearance, after making good around the flue terminal.

**Terminal Guard**, to be used when the terminal is fitted less than 2 m above a balcony, above ground or above a flat roof to which people have access.

Installation Instructions are supplied as necessary with the kits

Kit	Models & Part Numbers	
	FF55	FF75
Standard Flue System	225541	225541
2 Metre Flue System	225544	225544
Vertical Flue System	5106370	5106371
Terminal Wall Plate	212280	212280
Terminal Guard	205792	205792
Internal Fitment Kit	225184	225184
Pump Cover Kit (6in)	225418	225418
Pump Cover Kit (7in - 12in)	225419	225419
Pump Cover Kit (13in - 18in)	225420	225420
Pump Cover Kit (19in - 24in)	225421	225421

## 7. Short List Of Spare Parts

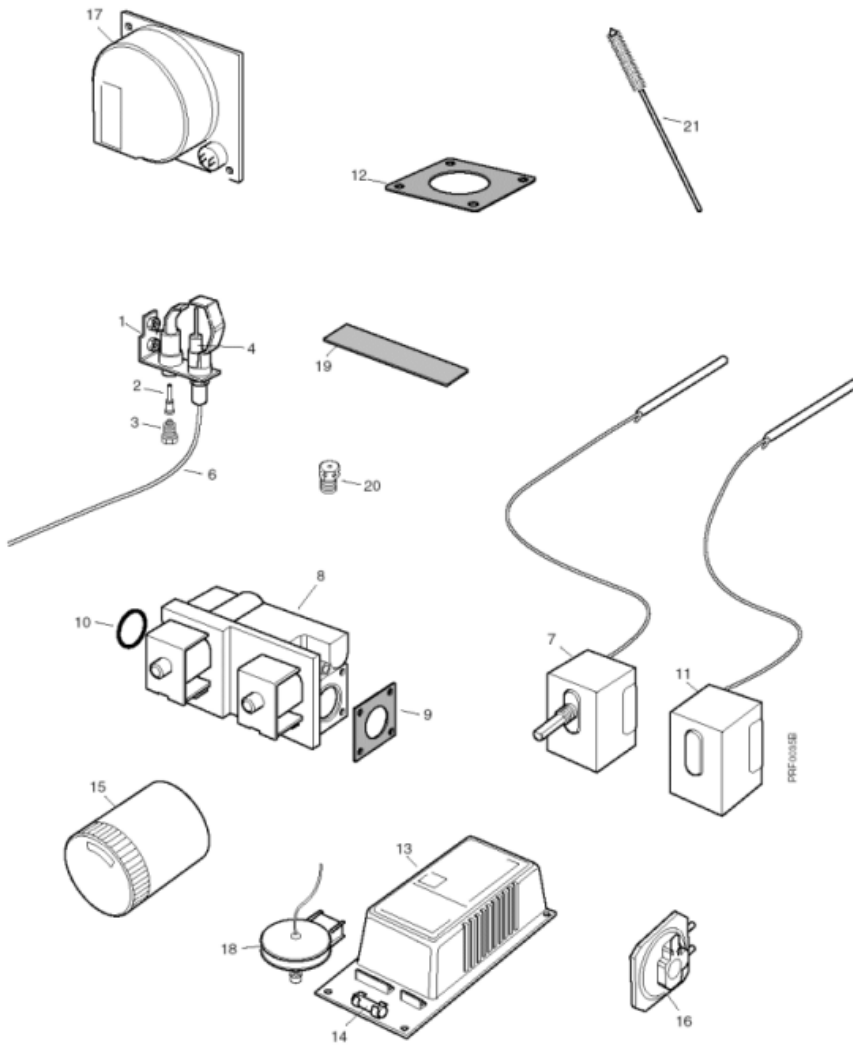

Fig. 32

Drg. Ref.	G.C. No.	Description	Qty	Part No.
1	382 453	Pilot Burner	1	402912
2	381 656	Pilot Injector	1	402915
3	357 714	Shear Off Union	1	402350
4	382 448	Electrode	1	402925
6	337 863	Electrode Lead	1	407697
7	385 853	Control Thermostat	1	404504
8	386 756	Gas Control Valve - Honeywell	1	907704
		Includes item 9		
9	337 480	Gas Manifold Gasket	1	212105
10	337 476	Gas Manifold 'O' Ring	2	401637
11	378 089	Gravity DHW/Pump Overrun Thermostat	1	404505
12	337 424	Flue Elbow Sealing Gasket	1	212084
13	382 462	Electronic Control	1	407677
14	337 338	Fuse 1 amp	1	907604
15	338 445	Thermostat Knob	1	225251
16		Pressure Switch - FF55	1	5105884
		Pressure Switch - FF75	1	5105887
17	382 445	Fan - FF75	1	409569
	289 903	Fan - FF55	1	409583
18	382 455	Overheat Thermostat	1	404495
19	337 371	Main Burner Gasket	1	212085
20	337 377	Main Burner Injector 3.8 mm - FF55	1	410968

	337 378	Main Burner Injector 4.4 mm - FF75	1	410969
21	337 372	Flue Brush (optional extra)	1	212154

Publication No. 5107093 - Iss. 01 (03/2002)

**General Enquiries**

Tel. **08706 060 780**

**Technical \***

Tel. **08706 049 049**

**Service \***

Tel. **08706 096 096**

Fax. **01926 410 006**

**Literature Request**

Tel. **08706 060 623**

\* To aid continuous improvement and staff training, calls to this line may be monitored or recorded.

All descriptions and illustrations provided in this leaflet have been carefully prepared but we reserve the right to make changes and improvements in our products which may affect the accuracy of the information contained in this leaflet. All goods are sold subject to our standard Conditions of Sale which are available on request.

**POTTERTON**

Baxi Potterton  
Brownedge Road, Bamber Bridge  
Preston, Lancashire  
PR5 6SN

[www.potterton.co.uk](http://www.potterton.co.uk)