

IDEAL MEXICO SLIMLINE 2 **B.E.D.** RS 40 & RS 50 Balanced Flue Gas Boilers Installation & Servicing

April
97

CAUTION

To avoid the possibility of injury during the installation, servicing or cleaning of this appliance, care should be taken when handling the edges of sheet steel components.

B.G.C. Appliance No.s

Ideal Mexico Slimline 2

RS 40 41 349 39

RS 50 41 349 40

NOTE: The appliances are for use with **NATURAL GAS ONLY.**

NOTE TO INSTALLER:

LEAVE THESE INSTRUCTIONS ADJACENT TO THE GAS METER

Appliance Type C₁₁

Table 1

GENERAL DATA

Boiler Size		RS 40	RS 50
Main Burner Bar		← Bray Mk.9 AB 16641 →	
Gas Control		← 1/2in. BSP Honeywell Compact V.4600 A. 1023 230v →	
Burner Injector		Bray Cat. 10 Size 1200	Bray Cat. 10 Size 1400
Pilot Injector		Honeywell 45004-108-001	
Gas Supply Connection	in. BSP	← Rc 1/2 →	
Flow Connections	in. BSP	← Rc 1 →	
Return Connections	in. BSP	← Rc 1 →	
Maximum Static Water Head	m (ft.)	← 30.5 (100) (3 bar) →	
Minimum Static Water Head	m (ft.)	← 1.0 (3.3) →	
Electric Supply	(Power Consumption)	← 230v ~ 50Hz (5 W) →	
External Fuse Rating		← 3 amp →	
Water Content	litre	16	20
	gal.	3.5	4.4
Dry weight exc. Bal. Flue terminal	kg	100	100
	lb.	220	220
Flue gas flowrate (max)	g/s	6.8	8.7
Flue gas temperature	°C	150	189
Boiler Input *	min. kW	11.3	15.0
	Btu/h x 1 000	38.5	51.2
	max. kW	14.5	18.5
	Btu/h x 1 000	49.4	63.2
Boiler Output to Water	min. kW	8.8	11.7
	Btu/h x 1 000	30	40
	max. kW	11.7	14.7
	Btu/h x 1 000	40	50
Burner Setting Pressure	min. mbar (gauge)	6.3	8.0
	in.w.g.	2.5	3.2
	max. mbar (gauge)	10.4	12.4
	in.w.g.	4.2	5.0

Note: * To obtain gas consumption (a) in cu.ft/h — divide heat input (Btu/h) by C.V. of the gas (Btu/cu.ft).

(b) in litres/second — divide heat input (kW) by C.V. of the gas (MJ/m³).



INTRODUCTION

The Ideal Mexico Slimline 2 RS 40 & RS 50 models are floor-standing balanced flue boilers, range rated, having outputs of 8.8 to 11.7 kW (30 00 to 40 00 Btu/h) and 11.7 to 14.7 kW (40 000 to 50 000 Btu/h) respectively.

The boiler casing is of mild steel, white enamelled top side, upper and lower front panel.

The boiler thermostat is located behind the lower front panel, in the control box mounted on the gas valve.

The boilers are suitable for connection to open vented systems only. The systems may be pumped, or gravity circulating indirect DHW only, pumped central heating only, or pumped central heating combined with either a pumped or gravity circulating indirect DHW circuit.

IMPORTANT.

This appliance range is certificated by the British Standards Institution for safety and performance. It is, therefore, important that no external control devices, e.g. flue dampers, economisers etc., are directly connected to these appliances unless covered by these 'Installation and Servicing' instructions or otherwise recommended by Caradon Ideal Ltd. in writing. If in doubt please enquire.

Any direct reconnection of a control device not approved by Caradon Ideal Ltd. could invalidate the B.S.I. certification and the normal appliance warranty. It could also infringe the Gas Safety Regulations.

Regulations, 1994

Gas Safety (Installation and Use) & Amendments, 1996
It is the law that all gas appliances are installed by CORGI registered installers (identified by Ⓢ) in accordance with the above regulations. Failure to install appliances correctly could lead to prosecution.

It is in your own interest, and that of safety, to ensure that the law is complied with.

The installation of the boiler must also be in accordance with I.E.E. Regulations, the by-laws of the Local Water Undertaking, any relevant requirements of the Local Gas Region and Local Authority, and the relevant recommendations of the following British Standards:

Codes of Practice:—

BS 6891 Low pressure installation pipes.

BS 6798 Boilers of rated input not exceeding 60kW.

BS 5449;1 Forced circulation hot water systems (smallbore and microbore domestic central heating systems).

BS 5546 Installation of gas hot water supplies for domestic purposes (2nd Family gases).

BS 5440;1 Flues (for gas appliances of rated input not exceeding 60kW).

BS 5440;2 Air supply (for gas appliances of rated input not exceeding 60kW).

Manufacturer's notes must not be taken, in any way, as over-riding statutory obligations.

LOCATION OF BOILER

The floor must be flat and level and of a suitable load bearing capacity. The boiler may be fitted on a combustible floor, and insulation, other than that required by the Local Authority and Building Regulations, is not necessary.

The boiler must be installed against an external wall, the back of the boiler cabinet may be fitted up to the wall.

The boiler may be installed in any room, although particular attention is drawn to the requirements of the I.E.E.

Regulations and, in Scotland, the electrical provisions of the Building Regulations applicable in Scotland with respect to the installation of the boiler in a room containing a bath or

shower. Where installation will be in an unusual position, special procedures may be necessary and BS 5376:2 gives detailed guidance on this aspect. A compartment used to enclose the boiler must be designed and constructed specially for this purpose. An existing cupboard or compartment may be used provided it is modified for the purpose. Details of the essential features of cupboard/compartment design, including airing cupboard installations, are given in BS 6798

In siting the boiler, the following limitations MUST be observed:—

1. The position selected for installation must allow adequate space for servicing in front of the boiler. Side clearance is only necessary for installation. The amount of side clearance will depend on the type of connections used. Where side units are modified to facilitate installation then no clearance is required.
2. This position MUST also permit the provision of a satisfactory balanced flue termination.

Timber Framed Buildings

If the boiler is to be fitted in a timber framed building it should be fitted in accordance with the British Gas publication 'Guide for Gas Installations in Timber Frame Housing', reference DM2.

GAS SUPPLY

The local Gas Region should be consulted at the installation planning stage in order to establish the availability of an adequate supply of gas.

An existing service pipe must not be used without prior consultation with the local Gas Region.

A gas meter is connected to the service by the local Gas Region or a local Gas Region contractor.

An existing meter should be checked, preferably by the Gas Region, to ensure that the meter is adequate to deal with the rate of gas supply required.

Installation pipes should be fitted in accordance with

BS 6891

Pipework from the meter to the boiler must be of adequate size. Do not use pipes of a smaller size than the boiler gas connection.

The complete installation must be tested for soundness as described in the above code.

FLUING

Detailed recommendations for fluing are given in BS 5440:1. The following notes are intended for general guidance:

1. The appliance MUST be installed so that the flue terminal discharges directly into the external air.
2. Termination should be on a clear expanse of wall, the terminal being preferably NOT less than 600mm (2ft) away from a corner, recess or projection.
3. Do NOT install the terminal:
 - (a) Within 300mm (1ft), measured vertically, from the bottom of an openable window, air vent or any other ventilation opening.
 - (b) Within 300mm (1ft) above adjacent ground level.
 - (c) Within 600mm (2ft) of any surface facing the terminal.
 - (d) Immediately below eaves or a balcony.
 - (e) Where it is subject to accidental obstruction.
4. Where the terminal is fitted within 1000mm(39½in) of a plastic or painted gutter, or 500mm(19½in) of painted eaves, an aluminium shield at least 1000mm(39½in) long should be fitted to the underside of the gutter or painted surface.

4. Where the lowest part of the terminal is less than 2m (6.6ft) above the level of any ground, balcony, flat roof or place to which people have access, the terminal MUST be protected by a guard of suitable material.

The dimensions of the guard shall be such that when fitted in accordance with the manufacturer's instructions, it shall be at least 50mm (2in.) from any part of the terminal, not including the wall plate.

The guard shall not have any sharp edges likely to cause injury, nor shall any opening permit the entry of a ball of 16mm diameter under a force of 5N.

The material finish and mechanical strength of the guard shall be such as to ensure a reasonable life in normal working conditions. The guard shall not affect the performance of the appliance.

Terminal guards are available from:—

Tower Flue Components Ltd., Vale Rise, Tonbridge, Kent TN9 1TB. (01732 - 351555).

5. The air inlet/products outlet duct, and the terminal of the boiler MUST be NOT closer than 50mm (2in) to combustible material.

Detailed recommendations on protection of combustible material are quoted in BS 5440:1.

BOILER TERMINAL

The terminal box of the balanced flue, with the addition, if necessary, of a duct extension, can be adapted to accommodate various wall thicknesses. Refer 'PACKAGING' (page 4).

Note: Where the boiler is to be installed in line with metric kitchen units (i.e. 600mm in depth), a special standard flue terminal is available.

AIR SUPPLY

Detailed recommendations for air supply are given in BS5440:2, the following notes being intended for general guidance:

It is not necessary to have a purpose provided air vent in the room in which the boiler is installed.

If the boiler is to be installed in a cupboard or compartment, permanent air vents are required, for cooling purposes, in the cupboard/compartment, at both high and low levels. These air vents may communicate with a room/internal space or direct to outside air.

The minimum effective areas of the permanent air vents required in the cupboard/compartment are as follows:—

RS.40

Position of air vent	Air from room/ internal space	Air direct from outside
High Level	140cm ² (22in ²)	70cm ² (11in ²)
Low Level	140cm ² (22in ²)	70cm ² (11in ²)

Note:

Both air vents must communicate with the same room, or internal space, or must both be on the same wall to outside air.

RS 50

Position of air vent	Air from room/ internal space	Air direct from from outside
High Level	190cm ² (30in ²)	95cm ² (15in ²)
Low Level	190cm ² (30in ²)	95cm ² (15in ²)

Note:

Both air vents must communicate with the same room, or internal space, or must both be on the same wall to outside air.

WATER CIRCULATION SYSTEM

The appliance must NOT be used for direct hot water supply, or for sealed systems.

The following indirect open vented systems are suitable:—
Combined gravity domestic hot water and pumped central heating. Combined pumped gravity domestic hot water and pumped central heating. Pumped central heating only. Gravity domestic hot water only, up to a minimum domestic hot water cylinder storage capacity of 180 litres (40-gal.).

The resistance with an 11.0°C temperature difference will be approximately 2in. w.g. (5 mbar). See page 15.

The central heating system should be in accordance with the relevant recommendations given in BS 6798 and, in addition, for small bore and microbore systems — BS 5449:1. The domestic hot water system, if applicable, should be in accordance with the relevant recommendations of BS 5546. Copper tubing to BS 2871:1 is recommended for water carrying pipework. The hot water storage cylinder MUST be of the indirect type and should be preferably manufactured of copper. The hot water cylinder and ancillary pipework not forming part of the useful heating surface, should be lagged to prevent heat loss and any possible freezing, particularly where pipes are run through roof spaces and ventilated under floor spaces.

The flow and return connections to a fully pumped system may be made either at one side of the boiler or diagonally, to suit convenience. In a combined pumped heating and gravity domestic hot water system, the gravity flow and return connections must be made to the same side of the boiler, and the pumped connections to the opposite side. The boiler MUST be vented. If venting cannot be done via a flow connection, a separate vent must be fitted by the installer.

Draining taps must be located in accessible positions which permit the draining of the whole system, including the boiler and hot water storage vessel. Draining taps should be at least ½in. nominal size and be in accordance with BS 2879.

WATER TREATMENT

The heat exchangers fitted to the above boilers have been internally treated with aluminium paint and only the following water treatment products should be used:

Fernox Copal or Sentinel X100

For further information on these products contact:

Fernox Manufg. Co. Ltd.	Sentinel Division
Britannica Works	Grace Dearborn
Clavering	Widnes
Essex	Cheshire
CB11 4QZ	WA8 8UD

Tel: 01799 550 811

Tel: 0151 424 5351

ELECTRICAL SUPPLY

WARNING: the appliance MUST be efficiently earthed.

A mains supply of 230V ~ 50 Hz single phase, fused at 3A, is required.

All external controls and wiring MUST be suitable for mains voltage.

Wiring external to the boiler MUST be in accordance with current I.E.E. Wiring Regulations and local regulations.

INSTALLATION

IMPORTANT: - BEFORE COMMENCING INSTALLATION remove the flue cleanout cover, [4] Fig.2 and ENSURE that the flue restrictor, sited over the flueway fins during works assembly, is in its correct position as illustrated on the right.

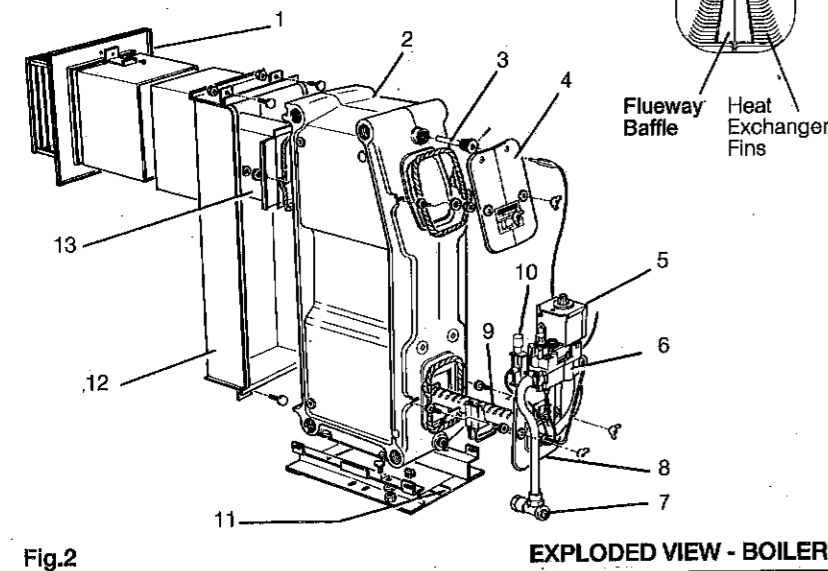

Fig.2 EXPLODED VIEW - BOILER

LEGEND - Fig. 2

- | | | | |
|----------------------|-------------------|----------------|----------------|
| 1. Terminal grille | 4. Cleanout cover | 8. Front plate | 12. Air duct |
| 2. Heat exchanger | 5. Control box | 9. Main burner | 13. Flue duct. |
| 3. Thermostat pocket | 6. Gas valve | 10. Piezo unit | |
| | 7. Gas cock | 11. Data plate | |

Allow adequate space in front of the boiler for servicing purposes.

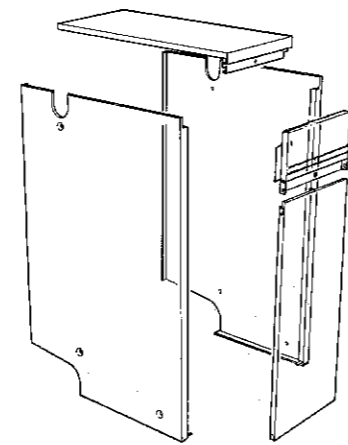

Fig.3 EXPLODED VIEW - JACKET

PACKAGING

The boiler is supplied fully assembled, and despatched in one carton, together with either one or two of four cartons: B; B1; C or D.

Cartons B, B1 & C contain the terminal outlet appropriate to the wall thickness. Carton D contains the flue duct extensions

Supplied in carton	Boiler fitted flush to wall Wall thickness	Boiler fitted in line with metric kitchen units Wall thickness
C	114 to 191 (4 1/2 to 7 1/2)	up to 125 (up to 5)
B	229 to 308 (9 to 12)	163 to 242 (6 1/2 to 9 1/2)
B1	319 to 398 (12 1/2 to 15 1/2)	253 to 332 (10 to 13)
B & D	406 to 584 (16 to 23)	340 to 518 (13 1/2 to 20 1/2)

Note: All dimensions in mm (in.)

The boiler is to be floor standing & the space in which the boiler is to be fitted must have the following dimensions;

- Width 265 (10.5 in.)
- Depth 535 (21 in.)
- Height 870 (34 1/4 in.)

This space includes the following minimum clearances for installation & servicing;

- At the top of the boiler 20 (3/4 in.)
- At each side of the boiler 5 (3/16 in.)

In addition the minimum clearance of 533 mm (21 in.) must be available at the front of the boiler to enable servicing.

To avoid damage to the boiler jacket it is recommended that the jacket is removed before the boiler body is taken off the pallet. Lift off the lower front panel, then by unscrewing the 2 self tappers located at the bottom edge of the upper front panel

push back & remove the upper front panel. Lift off the jacket top panel, then by unscrewing the 3 pozi screws securing each side panel to the boiler body, lift off & remove the side panels. The cardboard fitting on the boiler cleanout cover must be removed before installation.

The jacket may now be replaced, prior to the completion of the pipework.

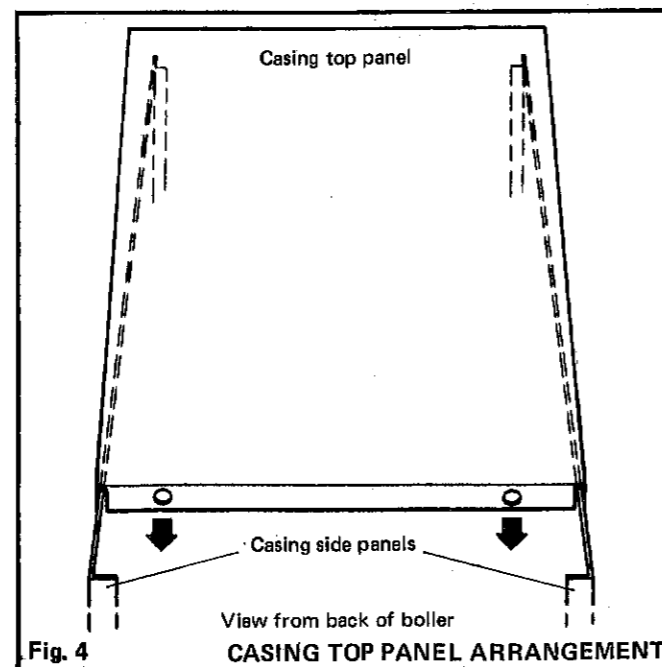

Fig. 4 CASING TOP PANEL ARRANGEMENT

DIMENSIONS

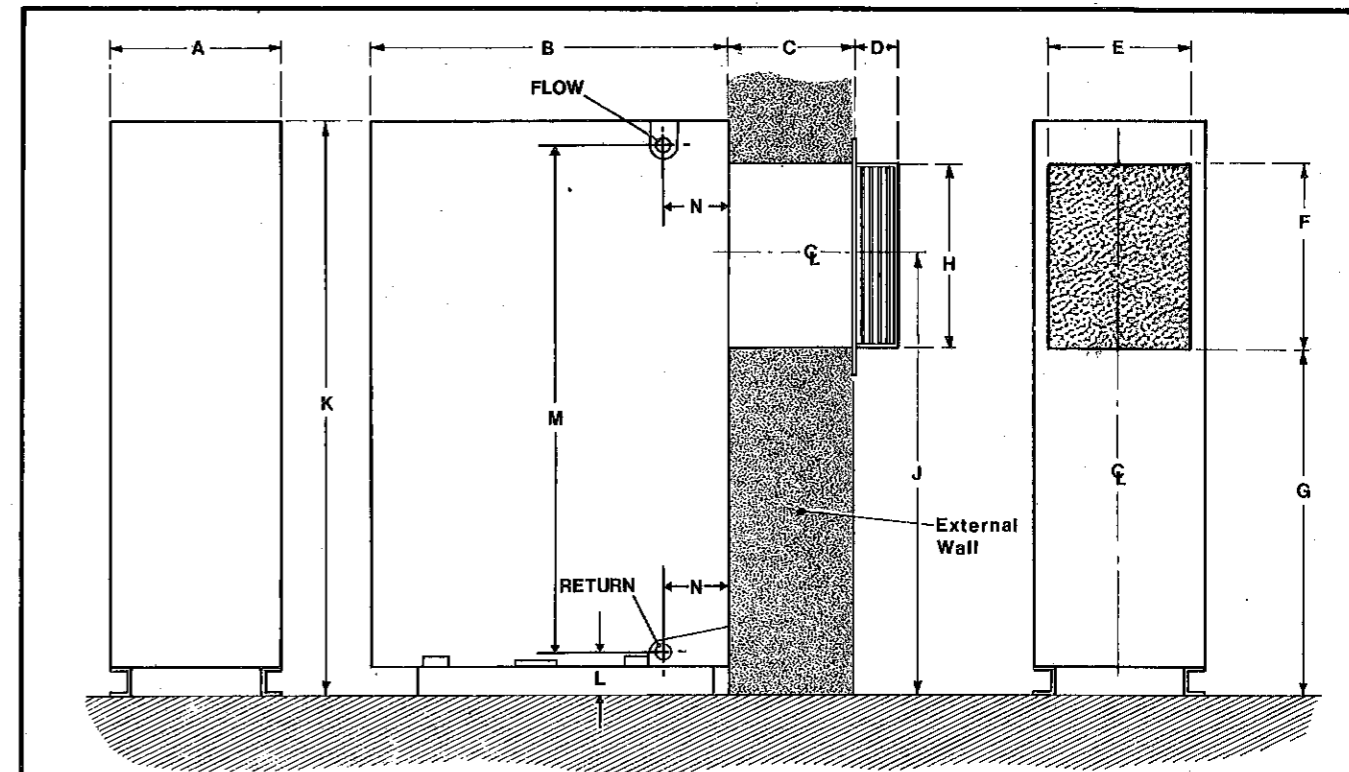

Fig. 5

Dimension	A	B	C	D	E	F	G	H	J	K	L	M	N
Metric mm	255	535	**	110	200	280	520	280	660	850	75	740	140
Imperial in	10	21	**	4.3	7.9	11	20.5	11	25.9	33.5	3	29.1	5.5

Note: ** Dimension 'C' - Variable

Cut a suitable opening in the wall (refer Fig. 5). The brick courses will probably dictate a larger hole than the one indicated. The installer is advised to make good the hole in the inner skin to the given dimensions before fitting the boiler. This will ease the job of sealing between the terminal box and the wall after the boiler has been fixed in position. The terminal box must not come into contact with combustible material, such as that used in non-standard constructions of timber framework and plaster board etc. If in difficulty, the Local Gas Region will advise. Remove the heat exchanger from the pallet by removing the two M6 nuts and bolts and place it in the selected position ready for water and flue connections.

FITTING THE FLUE DUCT ASSEMBLY AND TERMINAL GRILLE. (See Figs. 6 and 6A)

Separate the terminal grille (A) from the terminal duct assembly (B) by removing the two screws (C).

Smear mastic liberally on the inner surface of the boiler air duct (G) and the outer surface of the terminal air duct (F). The end of each duct should be coated to a minimum depth of 25mm (1in). From outside the building pass the duct assembly through the opening and slide it into the boiler outlet. Ensure the flue duct (D) slides over the boiler flue outlet (E) and the air duct (F) slides into the boiler air duct (G). Push the terminal duct assembly in until the side fixing brackets (H) contact the wall face. Make good between wall and ducts, inside and outside the building. When thoroughly dry, fasten the terminal grille to the flue duct assembly with the two screws.

EXTENSION DUCTS

Extension ducts are available for installations where the wall thickness exceeds 318mm (12 1/2in). They are used to bridge the gap between the appliance terminal box and the flue duct assembly and no other method should be used. Neither should the gap be left unbridged.

FITTING THE EXTENSION DUCT

The extension duct has ends of unequal size corresponding to the thickness of the metal. Take the larger duct and apply

mastic liberally over 25mm (1in) of the outer surface of the smaller end. Next, similarly apply mastic to 25mm (1in) of the inner surface of the boiler terminal air duct. (This is the outer duct). Slide the small end of the air duct extension through the wall opening and approximately 51mm (2in) into the boiler terminal box air duct. Slide the large end of the flue duct extension over the boiler terminal box flue duct approximately 51mm (2in). Apply mastic liberally to the first 25mm (1in) of the inner surface of the air duct extension and the outer surface of the terminal duct assembly air duct.

Now fit the terminal duct assembly from outside the building. (The terminal grille must be removed by means of screws (C)). Slide the flue duct OVER the extension flue duct and the air duct INTO the extension air duct. Push the terminal duct assembly inward until the fixing brackets contact the wall surface.

Make good inside and outside the building around the wall opening and fit the terminal grille.

WATER CONNECTIONS (Fig. 5)

This appliance is NOT suitable for use in either a sealed system or a direct system.

All water connections are Rc1 (1in.BSP). The front top and bottom plugged connections MUST NOT BE USED.

Two spare blanking off plugs are provided, in the hardware pack, for use as necessary in the rear flow or return water connections.

Pipework connections to all systems may use flow and return connections on the same side, or opposite sides of the boiler.

That is:-

Fully Pumped System

In a fully pumped system, either a LH or a RH flow connection, together with a LH or RH return connection, may be used.

Gravity Domestic Hot Water and Pumped Central Heating

In a gravity DHW and pumped CH system separate flow and return connections are used for each service.

The use of a cylinder thermostat is recommended. This will

prevent excessive domestic hot water temperatures and thus reduce gas consumption.

The schematic pipework graph following in Fig. 7 has been calculated on the assumption that not more than eight elbows are used in the gravity loop, including entry to the boiler.

For each extra elbow in excess of eight, (R) must be reduced by 300mm (12in), or (H) increased by 100mm (4in). The

pipe runs for gravity circulation should be planned with reference to the diagram and graph illustrated by Fig. 7. Whatever value is selected for 'R' (i.e. the horizontal distance between the centre line of the cylinder and the boiler tapplings used — measured along the pipe run) the value of 'H' (i.e. the vertical distance between the top of the boiler and the base of the cylinder) MUST be at least that indicated by the graph.

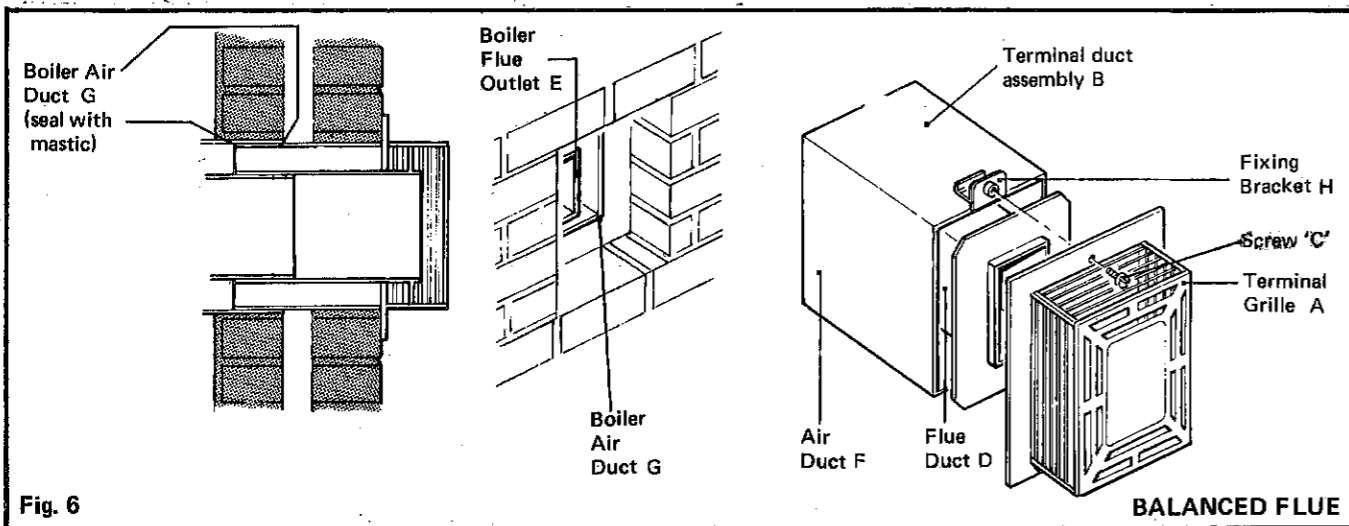

Fig. 6

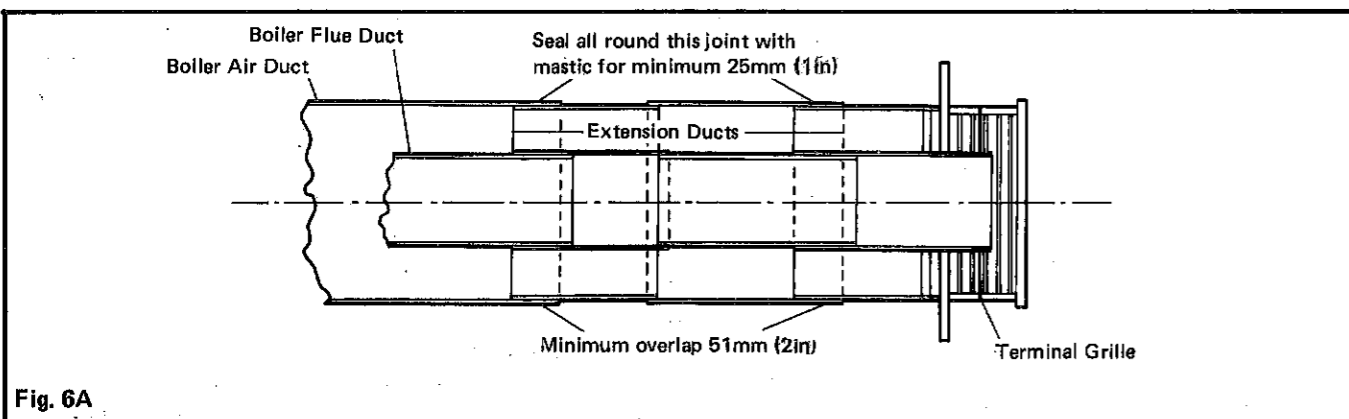

Fig. 6A

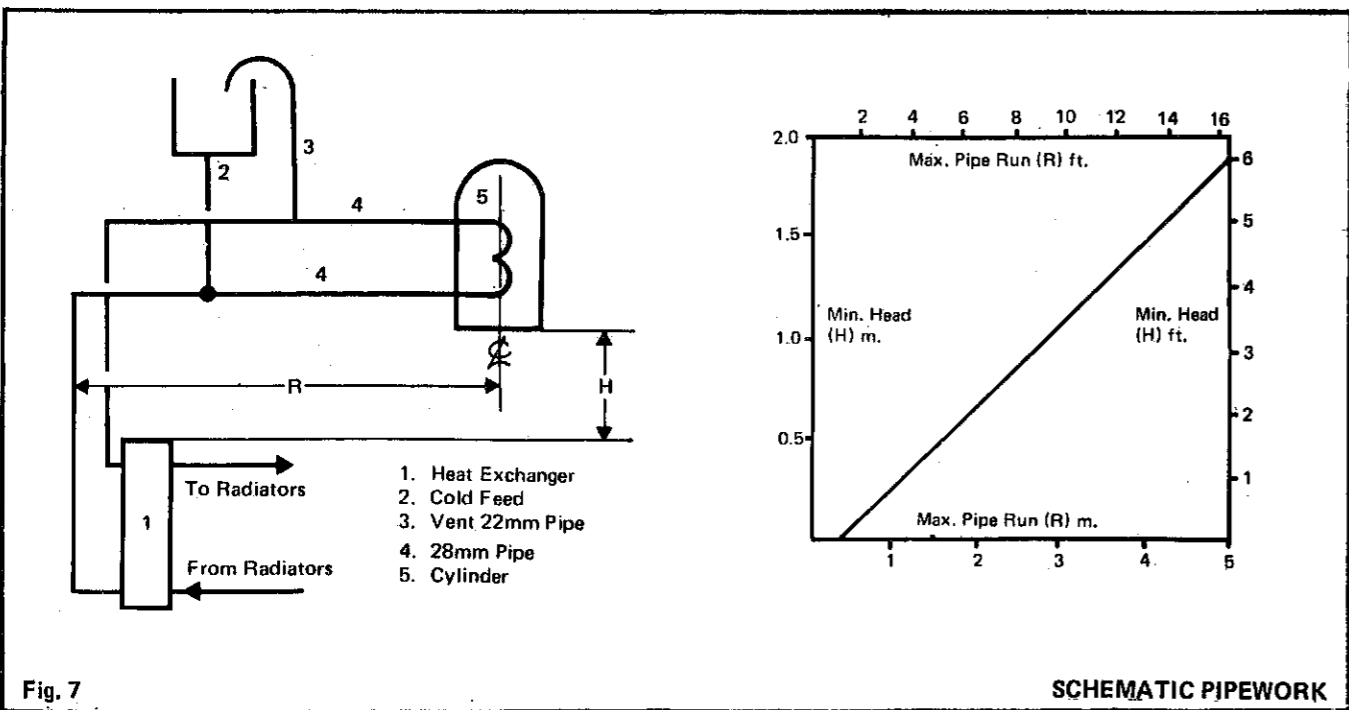

Fig. 7

GAS CONNECTIONS

A minimum gas pressure of 20 mbar (8in.w.g.) MUST be available at the boiler inlet. The main gas cock is at the bottom left of the boiler and attachment to the gas supply may be either LH or RH.

ELECTRICAL CONNECTIONS

WARNING: The appliance MUST be efficiently earthed.

A mains supply of 230 V ~ 50Hz single phase is required.

All external controls and wiring MUST be suitable for mains voltage.

Wiring should be in 3 core PVC insulated cable NOT LESS than 0.75mm² (24 x 0.2mm) to BS. 6500, Table 16.

Wiring external to the boiler MUST be in accordance with current I.E.E. Wiring Regulations and local regulations.

The supply connection MUST be made to a fused double pole switch, having a 3mm (1/8") contact separation in both poles, serving only the boiler and system controls.

The fuse rating should be 3 A.

This connection should be readily accessible and be made adjacent to the boiler (except in the case of bathroom installations for domestic boilers where the point of connection to the mains MUST be outside of the bathroom.)

Wiring within the boiler casing must be neatly secured in

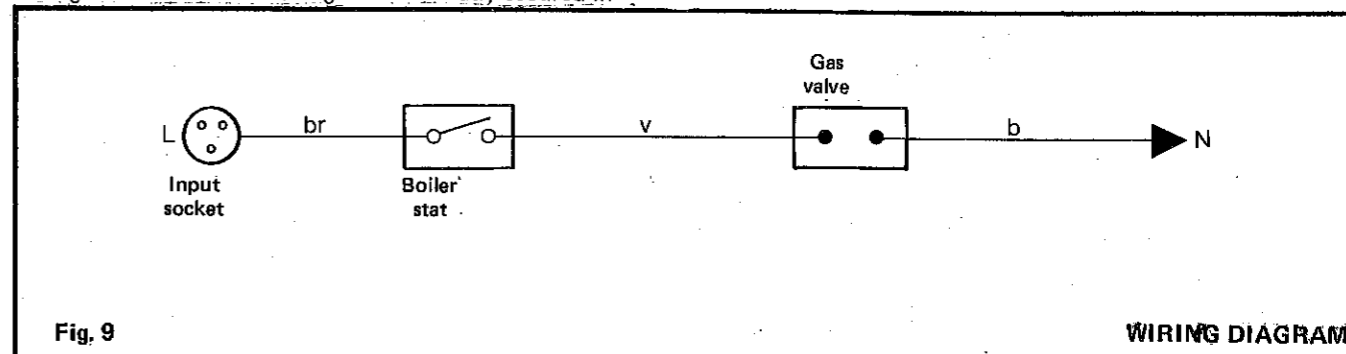

Fig. 9

WIRING DIAGRAM

the cable clips provided and such wiring must not be permitted to touch the burner plate or the cleanout cover.

INTERNAL WIRING

Remove the top of the control box to gain access to the internal wiring. The internal wiring is illustrated in Figs. 9 and 10.

A wiring diagram is also contained in the lighting instruction plate inside the front casing panel.

Note:

The mains lead to the control box must be secured in the cable clip provided.

EXTERNAL CONTROLS

The wiring diagrams illustrated by Figs. 11-17 cover the systems most likely to be fitted to this appliance. All possible combinations of external controls cannot be illustrated. Difficulty in wiring up should not arise providing the following directions are observed:

1. Controls that switch the system ON and OFF (e.g. a time switch) MUST be wired in series in the live mains lead to the boiler.
2. Controls that over-ride an ON/OFF control (e.g. a frost thermostat) MUST be wired into the mains lead in

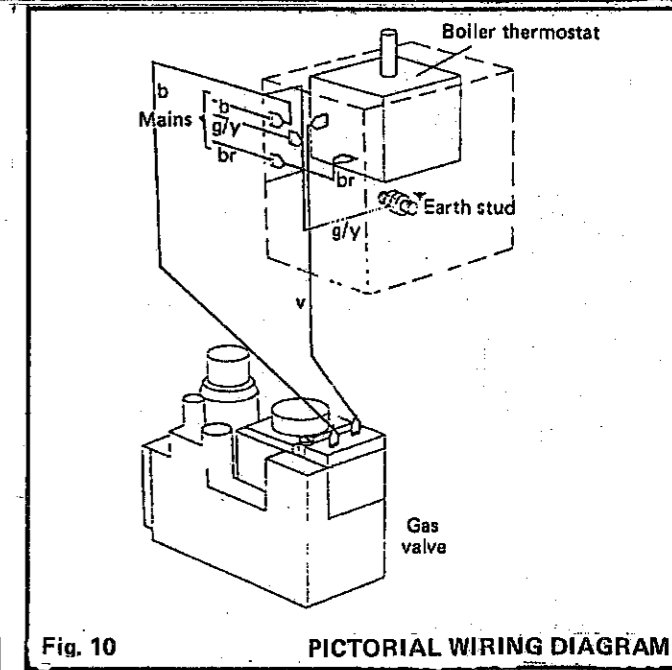

Fig. 10

PICTORIAL WIRING DIAGRAM

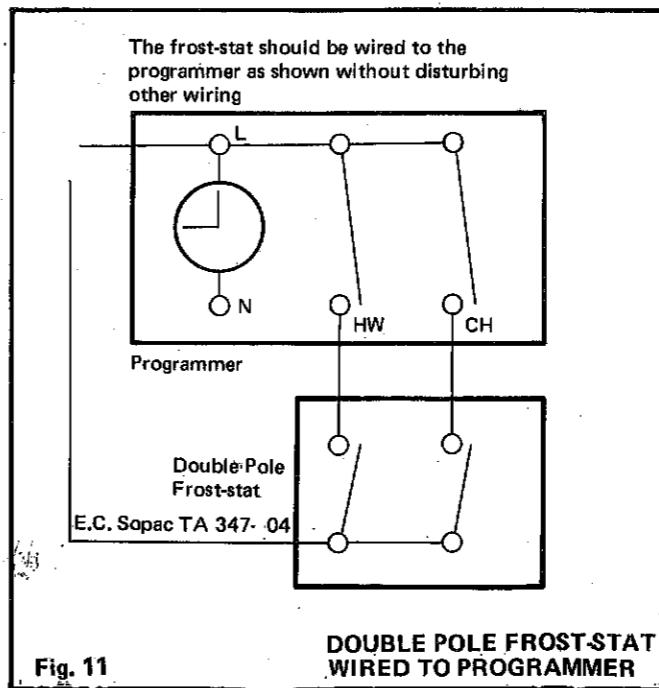

Fig. 11

DOUBLE POLE FROST-STAT WIRED TO PROGRAMMER

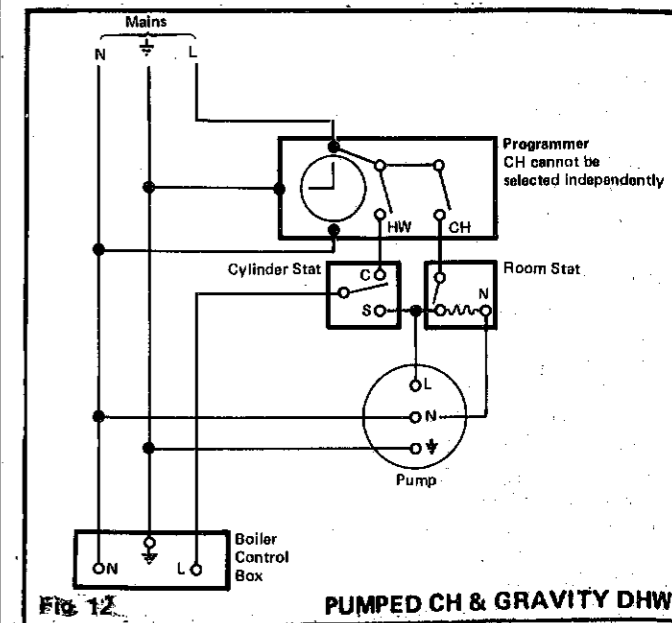

Fig. 12

PUMPED CH & GRAVITY DHW

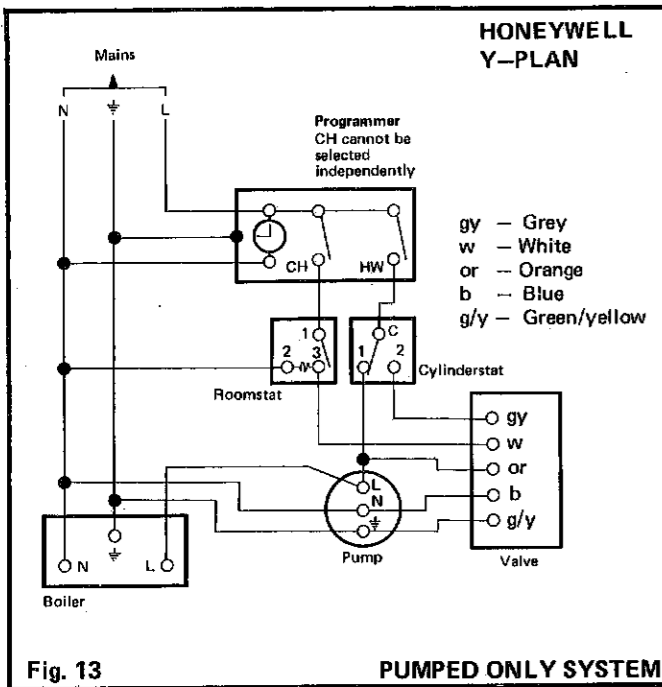

Fig. 13 PUMPED ONLY SYSTEM

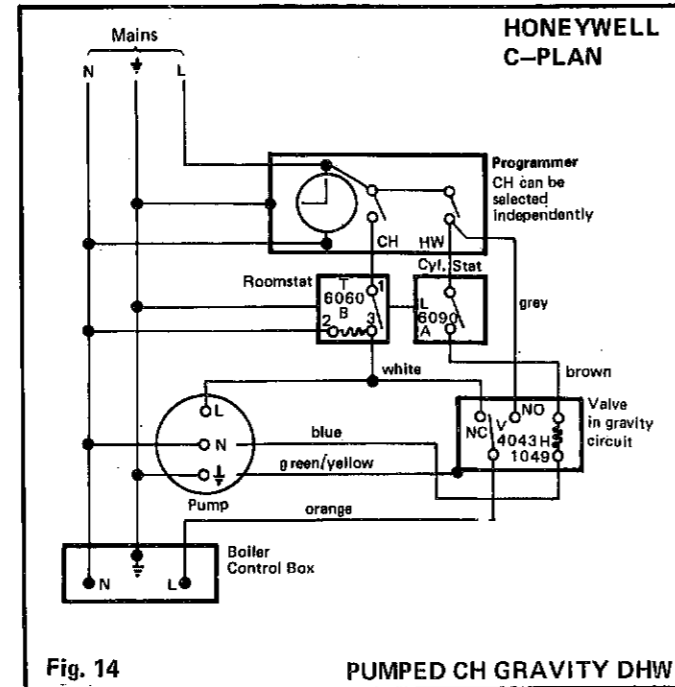

Fig. 14 PUMPED CH GRAVITY DHW

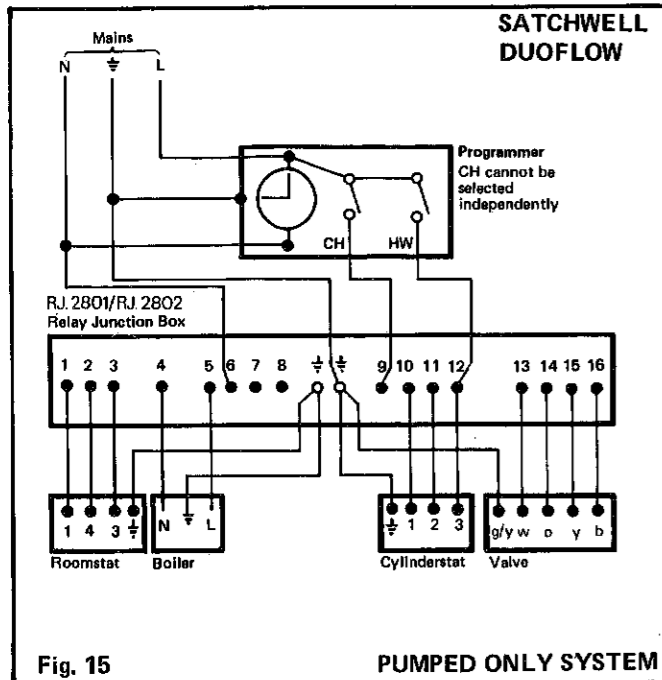

Fig. 15 PUMPED ONLY SYSTEM

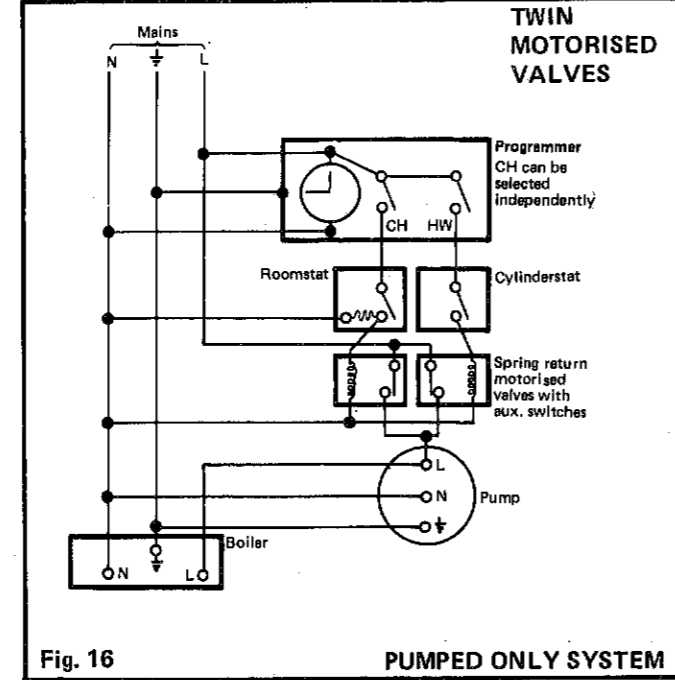

Fig. 16 PUMPED ONLY SYSTEM

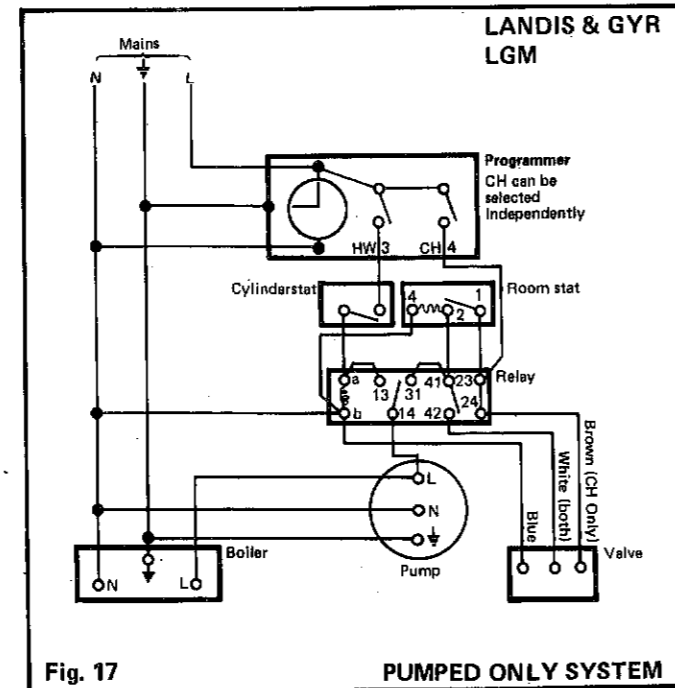

Fig. 17 PUMPED ONLY SYSTEM

parallel with the control(s) to be over-riden (see Fig.11).
 3. Controls that switch the circulating pump only ON and OFF (e.g. a room thermostat) MUST be wired in series with the pump in the live pump lead.
 4. If a proprietary system is used, follow the instructions supplied by the manufacturers.

Wire the mains connector, supplied in the bag of fittings, as follows:

- Brown cable to the live pin (L)
- Blue cable to the neutral pin (N)
- Green/yellow cable to the earth pin

The connector may now be plugged into the control box.

Advice on required modifications to the wiring may be obtained from the component manufacturers.

Note:

1. Connections between the frost thermostat and the time control should be made without disturbing other wiring.
2. The frost thermostat should be sited in a cool place in the house, but where it can sense heat from the system.

COMMISSIONING AND TESTING

Electrical Installation

Checks to ensure electrical safety should be carried out by a competent person.

Gas Installation

The whole of the gas installation, including the meter, should

be inspected and tested for soundness, and purged in accordance with the recommendations of BS 6891. Purging air from the gas installation may be expedited by removing the cabinet front panel of the boiler, loosening the union on the inlet gas cock and purging until gas is smelt. Re-tighten the union and check for gas soundness.

WARNING

Whilst effecting the required gas soundness test and purging air from the gas installation, open all windows and doors, extinguish naked lights, and do NOT smoke.

Water Circulating System

The whole of the system should be thoroughly flushed out with cold water WITHOUT the pump in position. Ensure that all valves are open.

With the pump fitted, the system should be filled and air locks cleared. Check for water soundness.

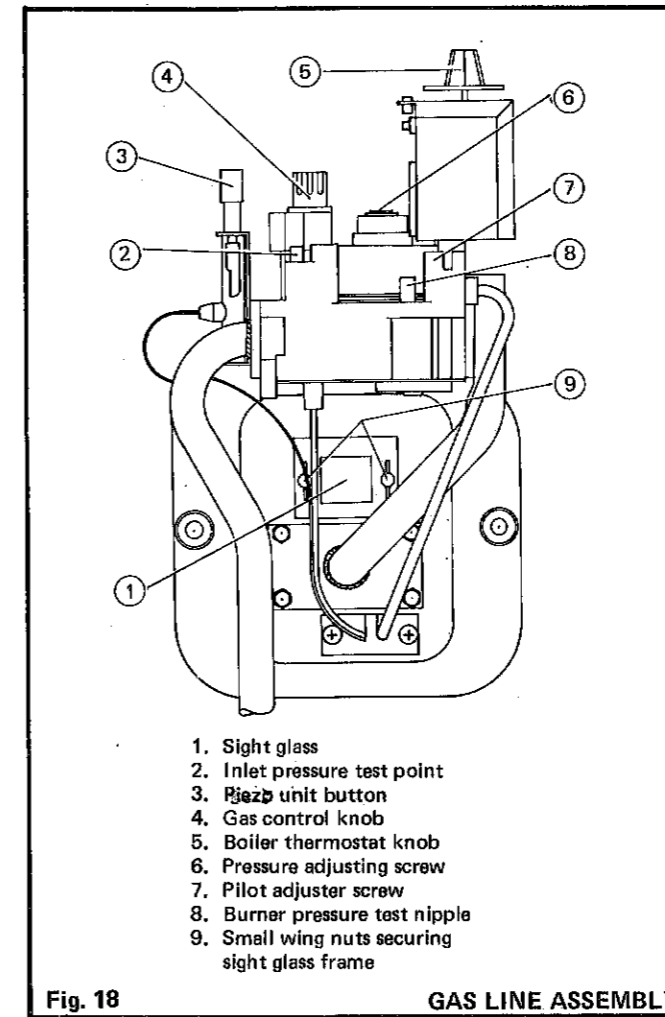

Fig. 18 GAS LINE ASSEMBLY

INITIAL LIGHTING INSTRUCTIONS (Refer Fig. 18)

The inlet gas cock must have been OFF for at least three minutes before initiating the lighting sequence. Check that all drain cocks are closed and that stop valves in the flow and return lines are open. Check that the inlet gas cock is ON and that the boiler thermostat control knob is at OFF. Loosen the screw in the burner pressure test nipple (8) and connect a gas pressure gauge via a flexible tube. Turn the gas control knob (4) clockwise until resistance is felt and then release it. Wait for three minutes. Push in the gas control knob, press and release the piezo unit button (3) repeatedly, until the pilot is seen to light through the sight glass. Hold the gas control knob depressed for 20 seconds after the pilot burner has ignited. Should the pilot light go out, at this or any other stage, turn the gas control knob clockwise and release it. Wait for three minutes and then repeat the procedure detailed above, but wait longer than 20 seconds before releasing the gas control knob.

The pilot flame should cover 13mm (1/2in) of the thermo-

couple tip. Turn the pilot adjuster screw (7) anti-clockwise to increase the flame and clockwise to decrease it. Check that the electricity supply, and all external controls, are ON.

Turn the boiler thermostat knob (5) to position 6, the boiler will then light. Operate the boiler for ten minutes to stabilise the burner temperature. Test for gas leaks around boiler gas components using leak detection fluid. Check the burner setting pressure against the values quoted in Table 1. If the burner setting pressure requires adjusting, remove the protective cap and turn the pressure adjusting screw (6) clockwise to increase pressure and anti-clockwise to decrease it.

A screwdriver with a 10mm bit should always be used for adjustment to avoid damaging the plastic head on the screw. Replace the protective cap. Remove the gas pressure gauge and tube and re-tighten the sealing screw in the pressure test nipple. Check for gas leaks around test nipple.

If the piezo unit should not work for any reason, the boiler may be lit by means of a paper spill. Remove the sight glass (1) and position a lighted spill near the pilot burner. Push in the gas control knob and hold it depressed until the pilot burner lights; hold down the knob for a further 20 seconds. Replace the sight glass and effect the subsequent lighting procedure detailed in the foregoing instructions. Any fault on the piezo unit must be rectified.

GENERAL CHECKS

Make the following checks for correct operation:

1. Turn the boiler thermostat OFF and ON and check that the main burner is extinguished and re-lit in response.
2. Check the operation of the flame failure device in the gas control. The flame failure device must cut off the gas to the burner within 60 seconds. With the burner alight again turn the gas control knob clockwise until resistance is felt and then release it. The burner and pilot flames should shut down immediately.

Note:

- A latch in the gas control provides a safe delay period before the boiler can be re-lit.
- 3. Check the appearance of the pilot flame and, if necessary, make appropriate adjustment by use of the pilot adjuster screw, refer (7) Fig. 18 - 'Initial Lighting Instructions'.
- 4. The correct operation of external system controls should be proved. Turn each, in turn, to OFF and ON and check that the main burner or circulating pump, as the case may be, responds.
- 5. With the system HOT, examine all water connections for soundness. Then turn OFF the gas, electricity and water supplies to the appliance and drain down whilst the system is still hot in order to complete the flushing process. Refill and vent the system, and again check for water soundness.
- 6. Finally, set the controls to the User's requirements. The temperatures quoted below are approximate and may vary between installations:

Knob Setting	Flow Temperature	
	°C	°F
1	54	130
2	60	140
3	66	150
4	71	160
5	77	170
6	82	180

USER'S INSTRUCTIONS

After completion of installation of the appliance and commissioning the system, the Installer should hand over to the householder by the following actions:

1. Hand the supplied 'User's Instructions' publication to the householder and explain his/her responsibilities under the Gas Safety Regulations, 1994, & amendments. 1996

2. Draw attention to the Lighting Instruction Plate affixed to the inside of the front panel.
3. Explain, and demonstrate, the lighting and shutting down procedures.
4. The operation of the boiler and the use, and adjustment, of ALL system controls, should be fully explained to the householder, to ensure the greatest possible fuel economy, consistent with household requirements of both heating and hot water consumption. Advise the user of the precautions necessary to prevent damage to the system,

SERVICING

WARNING:

Switch OFF, and disconnect, the electricity supply and turn OFF the inlet gas cock BEFORE servicing the boiler. A comprehensive service should be carried out at least once a year. The User is advised to make a contract with the Gas Region or a qualified Heating Engineer. Remove the lower front panel of the cabinet, then by unscrewing the two self tapping screws located at the bottom

5. Explain the function and the use of the boiler thermostat and external controls.
6. Explain, and demonstrate, the function of time and temperature controls, radiator valves etc., in the economic use of the system.
7. Stress the importance of regular servicing by the Gas Region or by a qualified Heating Engineer.

edge of the upper front panel push back and remove the upper front panel. Unscrew the union nut at the main gas cock. Disconnect the mains plug from the boiler control box. Remove the phial of the boiler thermostat from its pocket. Remove the wing nuts and washers, securing the burner front plate, and remove the burner assembly complete with the gas valve, control box and associated gas line etc., from the boiler. Remove to a convenient working surface for attention. When replacing a defective main burner bar, it is most important that the baffles (refer Fig.20 - Items 13 & 14) are fitted to the new burner. (RS 50 only)

Inspect the pilot burner, thermocouple and ignition electrode ensure they are clean and in good condition.

In particular, check that:

1. The pilot burner is firmly secured
2. The pilot shield is clean and unobstructed.
3. The ignition electrode, and lead, are clean, undamaged and secure.
4. The thermocouple tip is not burnt or cracked.
5. The thermocouple terminal, at the gas valve, is clean and secure.
6. The pilot observation window is clean and undamaged.

FLUEWAYS

Remove the complete burner assembly (Figs. 19 and 20) and also the cleanout cover at the top of the boiler. Remove all loose deposits from the heat exchanger, particularly from the flueways formed between the fins, using a suitable flexible brush, (available from local Gas Regions, ref. No. 4798 A, C and K), and sweep the debris from the combustion chamber floor. Refit the cleanout cover and the burner assembly, replacing any damaged or deteriorated sealing gaskets. Complete the gas and electrical connections.

PILOT BURNER

Light the boiler and check that:

1. The pilot flame impinges on the thermocouple head and that the position of the thermocouple relative to the pilot burner, and the main burner, is as shown by Fig. 22. A or B
2. The pilot flame covers 13mm (1/2in) of the thermocouple tip. Turn the adjuster screw (7) - Fig.18, anti-clockwise to increase the flame, and clockwise to decrease it.

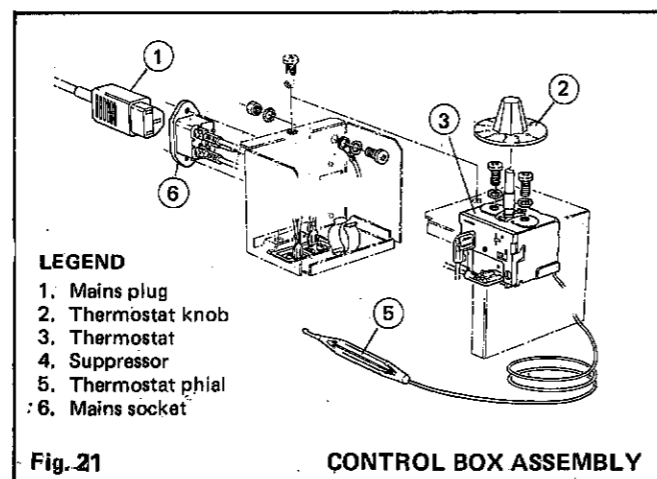

Fig. 21

CONTROL BOX ASSEMBLY

ADJUSTMENT OF GAS PRESSURE

After each occasion of servicing, reference should be made to Table 1 which quotes details of the rated output with the related burner setting pressure and heat input.

Any required adjustments should be made by using the pressure adjustment screw (6) illustrated in Fig. 18. Replace the upper and lower front panels in reverse order to that under the heading 'PACKAGING'

REPLACEMENT OF COMPONENTS

WARNING:

ALWAYS TURN OFF THE GAS SUPPLY AND SWITCH OFF THE ELECTRICITY SUPPLY BEFORE WORKING ON THE APPLIANCE.

Note:

To replace the following components it will be necessary to remove the casing lower front panel.

Sight Glass

Undo the two wing nuts holding the sight glass assembly to the burner front plate. When fitting the replacement assembly make certain the parts are in correct order i.e. gasket, glass, gasket and frame. Re-tighten the two wing nuts to ensure an air-tight joint but DO NOT OVERTIGHTEN.

Boiler Thermostat

Remove the electrical plug connection at the side of the control box. Remove the split pin and withdraw the phial from the pocket. Remove the screw on the top left hand side of the control box and lift away the top half of the control box from the bottom half of the control box. It is not necessary to disconnect the lead to the gas valve.

Pull off the thermostat knob and the two electrical connections to the thermostat head.

Unscrew the two screws holding the thermostat to the control box and withdraw the thermostat capillary from the plastic clip inside the control box. Fit the replacement thermostat and re-assemble in reverse order.

Piezo Unit

Unplug the igniter lead from the piezo unit body, remove the two nuts securing the body to the studs on the gas valve and fit the new unit. Re-connect the igniter lead.

Igniter Lead

Switch off the electricity supply and disconnect the mains plug from the boiler control box. Turn off the inlet gas cock and disconnect the union nut. Withdraw the boiler thermostat phial from the pocket after removing the split pin.

Remove the wing nuts securing the burner front plate. This plate, complete with burner assembly and gas line, can now be removed from the boiler. The igniter lead can be removed by disconnecting at the piezo unit and the electrode. Fit the new lead and re-assemble in reverse order.

Thermocouple

Remove the burner assembly as previously described. Undo the thermocouple connections at the pilot burner and gas valve. Fit new thermocouple. Avoid sharp bends in the thermocouple lead. Re-assemble in reverse order.

Electrode

Remove the burner assembly as above (under 'Igniter Lead' paragraph). Pull off the igniter lead at the electrode. The RS 40 electrode is held by a clip which should be gently prised aside; the electrode can then be withdrawn downwards.

The RS 50 electrode is secured by a nut. Remove the nut and withdraw the electrode upwards. Re-assemble in reverse order.

Pilot Burner

Remove the burner assembly (described under 'Igniter Lead'). Remove igniter electrode (described under 'Electrode'). Undo the thermocouple and pilot pipe connections at the gas valve and at the pilot burner. Undo the two screws holding the pilot burner to the pilot burner bracket. The pilot burner can now be withdrawn. Fit the new pilot burner, ensuring that the pilot injector is in position when refitting the pilot pipe, and re-fit the thermocouple and electrode. Re-assemble in reverse order.

Control Box

Disconnect the electrical plug connection at the left hand side of the control box. Remove the split pin and withdraw the thermostat phial from the pocket. Remove the screw on the top left hand side of the control box and withdraw the top half of the control box from the lower half.

Disconnect the leads from the gas valve. Remove the lower half of the control box from the gas valve by unfastening the securing screw. Fit the new control box in reverse order.

GAS VALVE AND MAIN BURNER

Remove the burner and control assembly as previously described under 'Igniter Lead'.

Main Burner

Undo the nut securing the pilot bracket to the main burner and remove the pilot bracket. Undo the four nuts securing the burner to the front plate and gas valve outlet pipe and withdraw the burner. Remove the nuts securing the burner baffle to the burner (ensure that this baffle is refitted to the new burner).

Fit the new burner in reverse order, being careful not to damage the main burner injector which is screwed into the end of the gas valve outlet pipe.

Gas Valve

Remove the control box as previously described. Remove the piezo unit by unfastening the two nuts which secure the body to the studs on the gas valve. Undo the pilot pipe and thermocouple connections at the gas valve.

Unfasten the two nuts and screws securing the gas supply pipe to the left hand side of the gas valve. Unfasten the four screws securing the gas valve outlet pipe. The two sealing 'O' rings should be discarded, and new 'O' rings fitted. Re-assemble in reverse order ensuring that the new gas valve is fitted the right way round (an arrow engraved on the gas valve indicates the direction of flow).

Ensure that the sealing 'O' rings are fitted correctly between the flanges on the end of the gas pipes and the gas valve. Check the complete assembly for gas soundness.

IMPORTANT

Use an approved jointing compound when replacing the main burner injector or service cock.

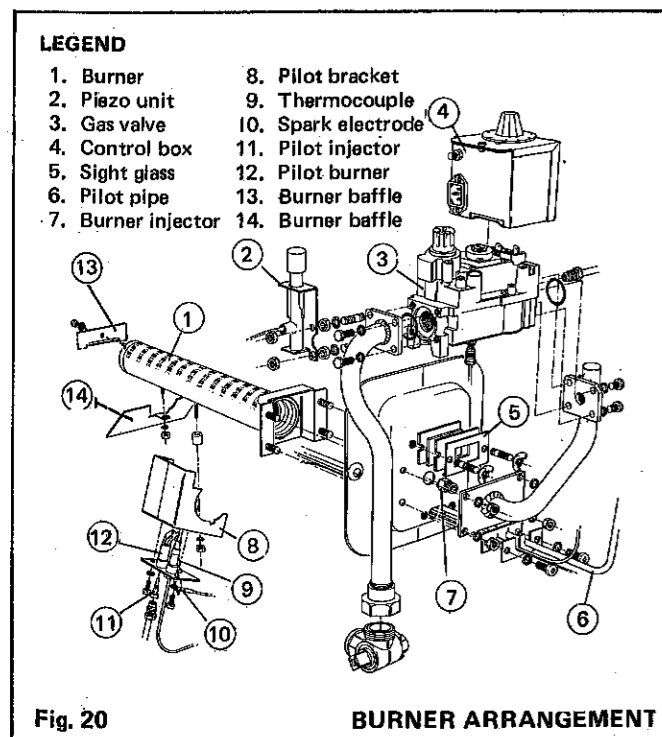

Fig. 20

BURNER ARRANGEMENT

FAULT FINDING

Detailed instructions on the replacement of faulty components will be found in the Servicing section of this booklet.

PILOT WILL NOT LIGHT:

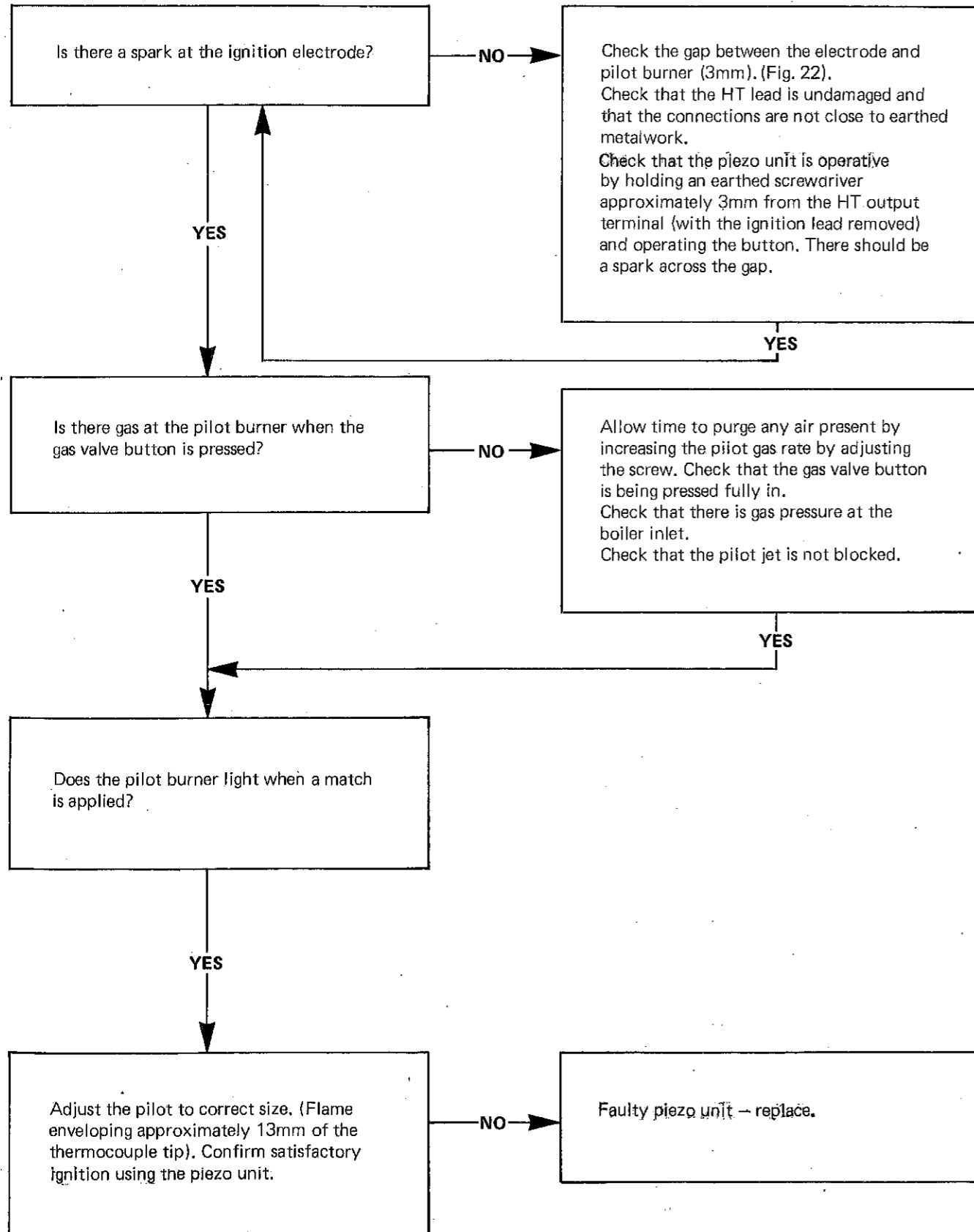

PILOT WILL NOT STAY LIT WHEN THE GAS VALVE BUTTON IS RELEASED:

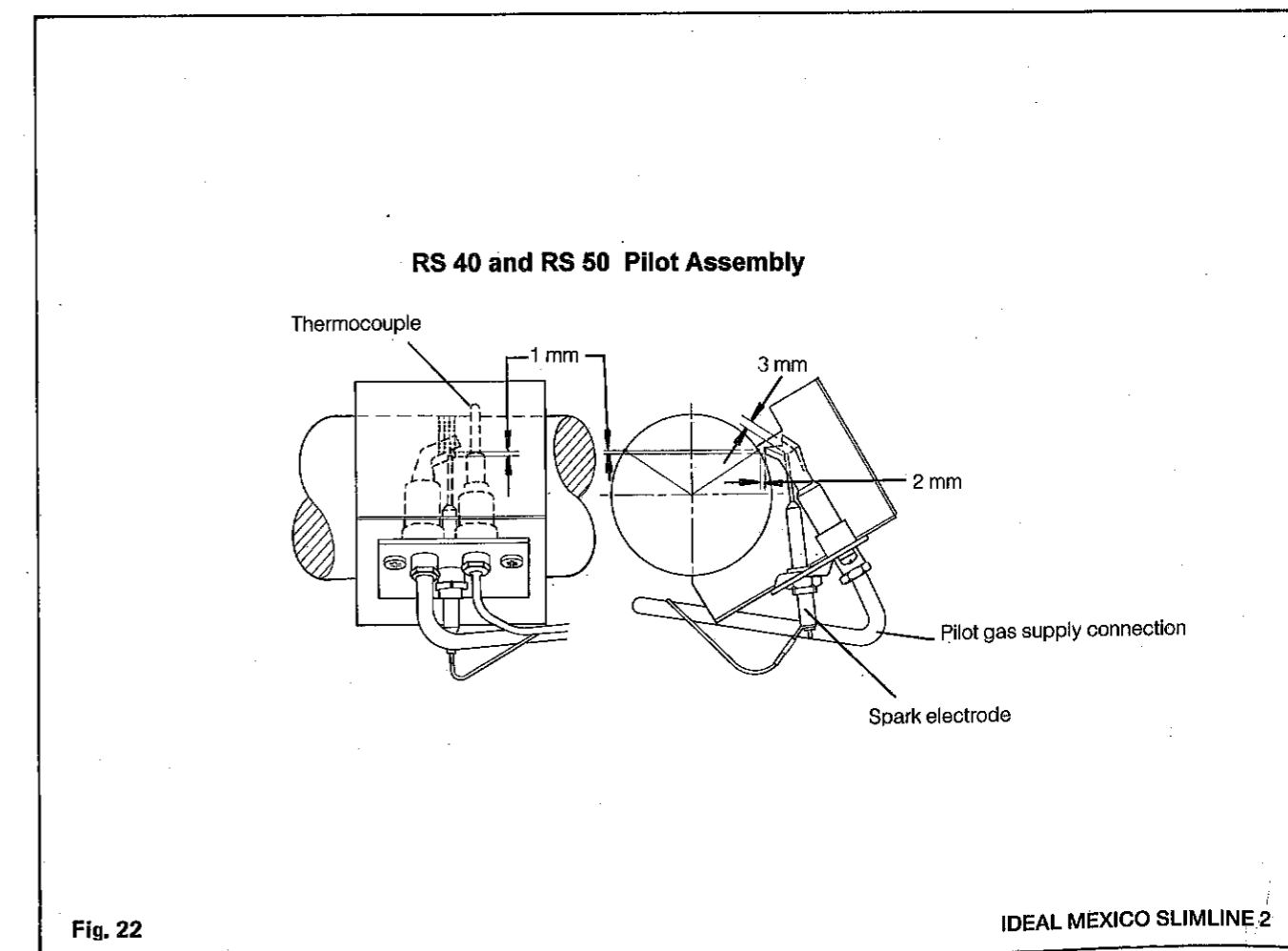
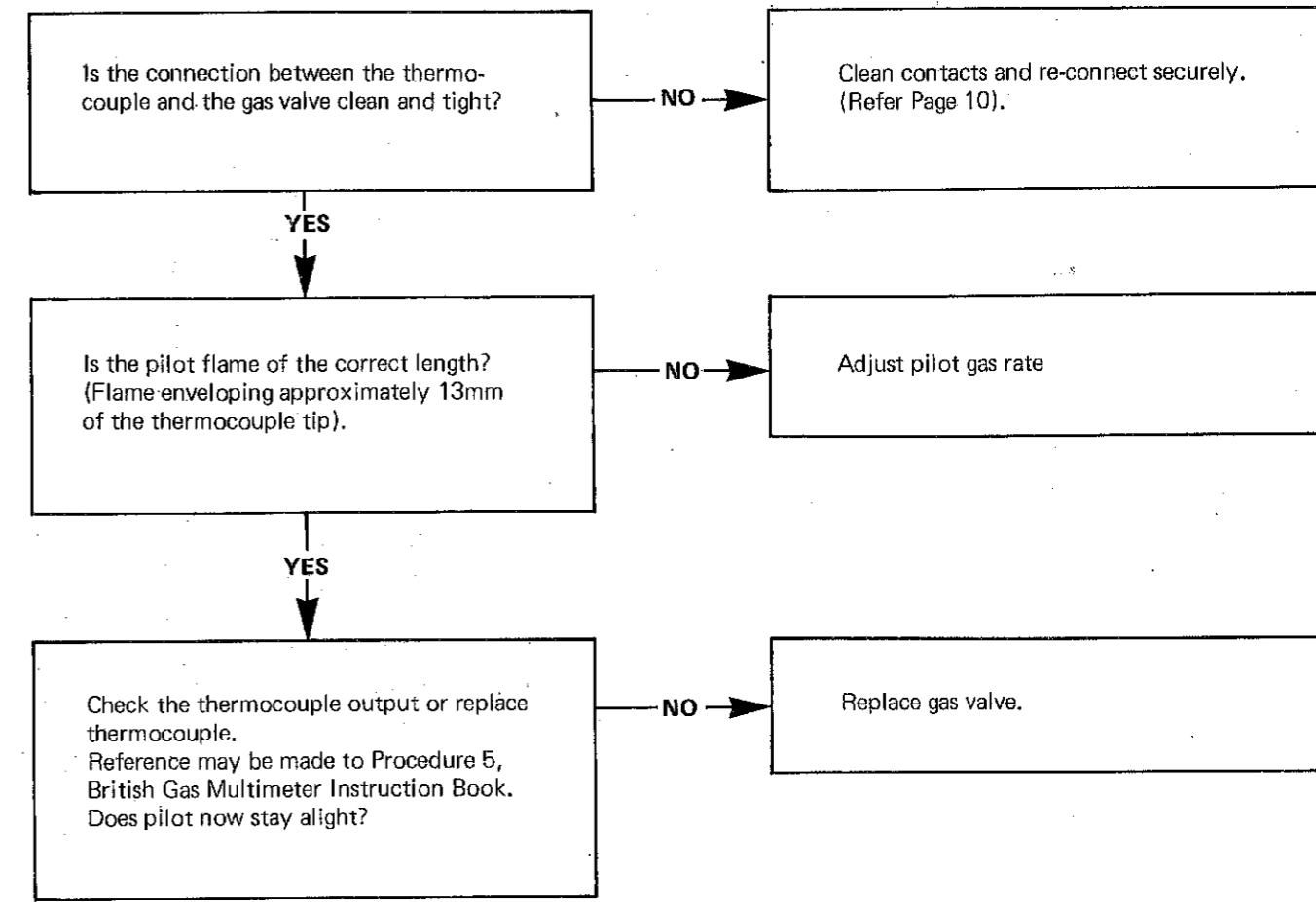
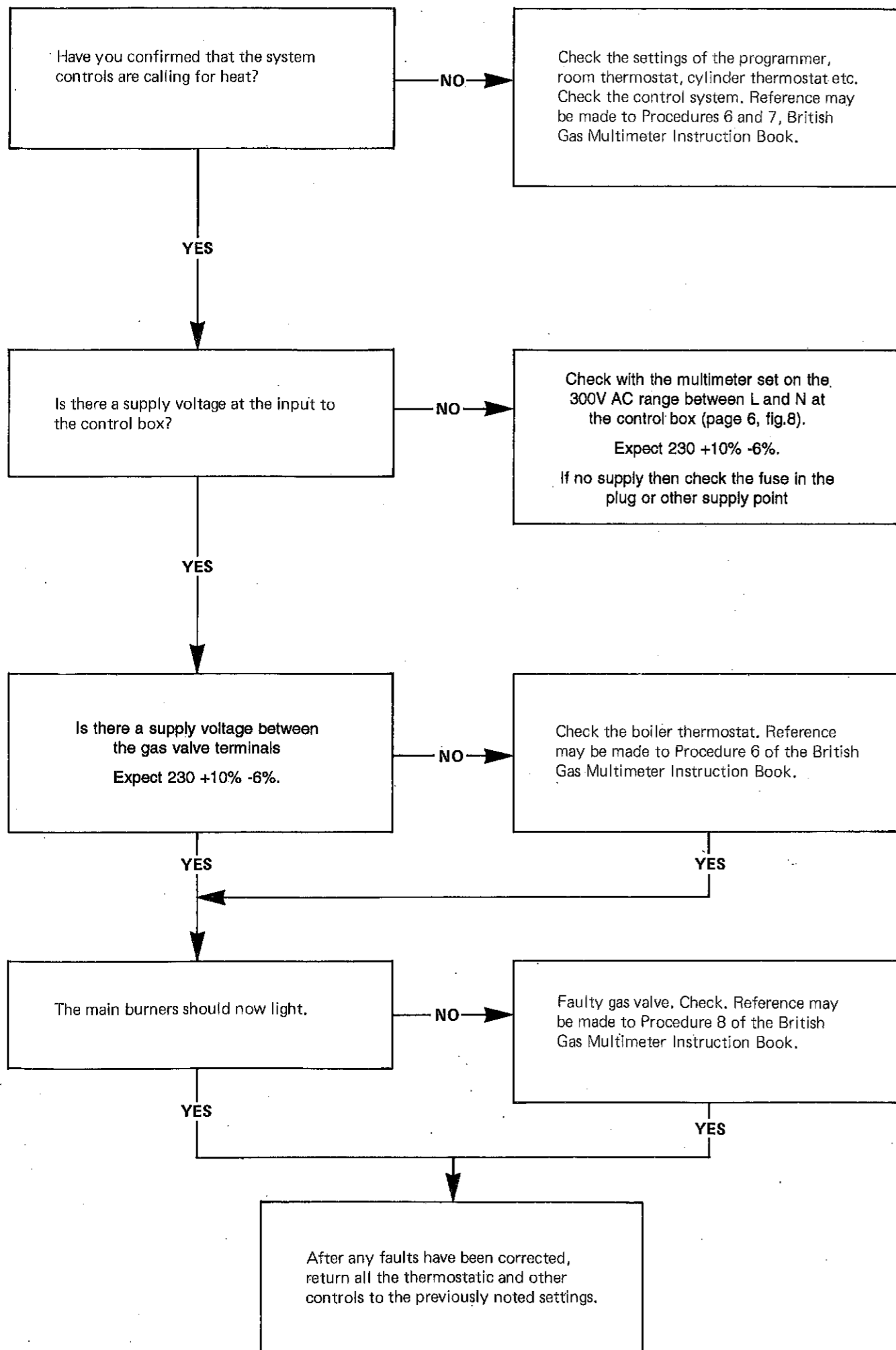

Fig. 22

PILOT LIT BUT NO MAINS GAS:



Water flow rate and pressure loss

Boiler size		RS & CF 40	RS & CF 50
Boiler	kW	11.7	14.7
Output	Btu/h	40,000	50,000
Water Flow Rate	l/sec	0.25	0.32
	gpm	3.3	4.2
Pressure Loss	kPa	0.27	0.40
	m ft	0.027 0.09	0.04 0.16



THIS SYMBOL IS YOUR ASSURANCE OF QUALITY

These appliances are designed for use with Natural Gas only. They have been tested and conform with the provisions of BS. 6332 and BS. 5258.



CERTIFIED PRODUCT
 Manufactured under a BS EN ISO 9001 : 1994 Quality System accepted by BSI

SHORT LIST OF PARTS

The following list comprises parts commonly required as replacements. It is extracted from the B.G.C. List of Parts which contains all available spare parts. Copies of the B.G.C. lists are held by Gas Regions, Caradon Ideal Ltd. distributors and by merchants.

IDEAL MEXICO SLIMLINE 2 RS 40/50 GAS BOILER

When ordering spares, please quote:

1. Boiler Model and size
2. B.G.C. Appliance Number
3. Description
4. Maker's Part Number
5. Quantity

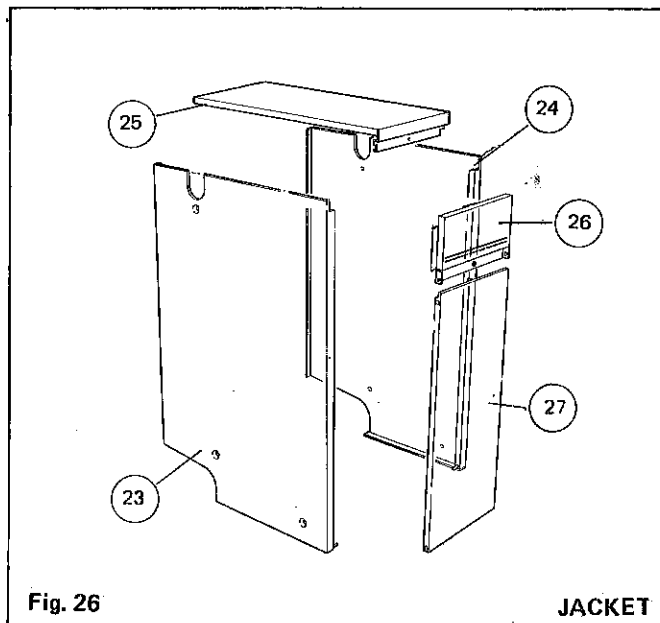
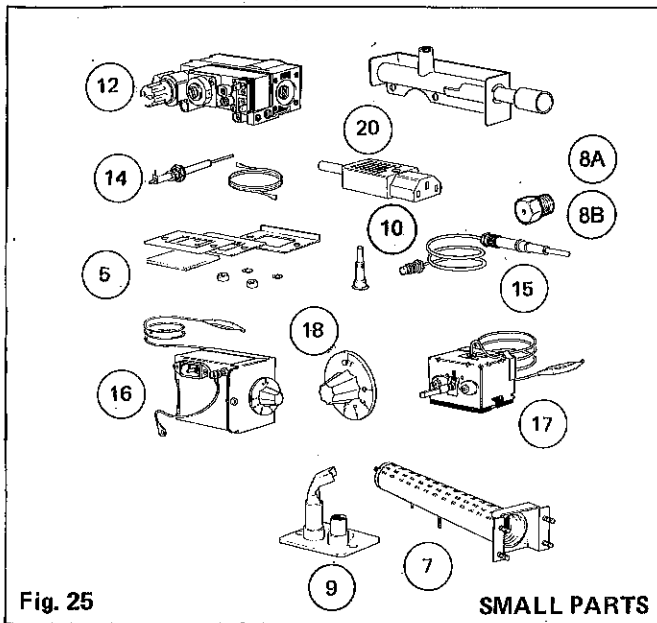

Key No.	B.G.C. Pt. No.	Description	No. Off	Maker's Pt. No.
5	319 494	Sight glass assembly kit	1	079334
7	398 251	Main burner Bray Mk. 9 AB 16641 (less injector)	1	012533
8A		Burner Injector (RS 40) Cat 10 1200	1	004190
8B	398 055	Burner Injector (RS 50) Cat 10 1400	1	003361
9	341 957	Pilot burner Honeywell Q359A 1041 complete with injector Key No. 10	1	077869
10	381 656	Pilot burner injector Honeywell 45004-108-001	1	003825
12	393 659	½in. BSP Honeywell Compact gas control V4600A 1023 240v	1	003114
13	393 894	Spark Generator Vernitron 60038/01	1	052288
14	341961	Ignition electrode and HT lead assy. (HT lead 460mm lg.)	1	007428
15	390 039	Thermocouple Honeywell Q309A 2739 600mm lg.	1	000842
16	341 060	Control box including Key Nos. 17, 18	1	053621
17	382 401	Thermostat Ranco CL6 P0104 with 24 in. capillary (replaces C26 P0616 interchangeable)	1	003178
18	382 327	Thermostat knob assembly (FASTEX)	1	002434
20	354 776	Mains connector Ashley or Bulgin to CEE 22 Sheet V and BS.4491	1	003069
22		Jacket White stove enamel with, White upper front panel including key No.s 23, 24, 25, 26 & 27	1	075304
23	341 062	LH Side jacket panel assy. White stove enamel	1	132258
24	341 063	RH Side jacket panel assy. White stove enamel	1	132259
25	341 064	Jacket top panel assy. White stove enamel	1	132262
26	319 346	Jacket upper front panel assembly. White stove enamel.	1	135914
27	E01 411	Jacket lower front panel assy. White stove enamel	1	075305

CARADON IDEAL Ltd. pursues a policy of continuing improvement in the design and performance of its products. The right is therefore reserved to vary specification without notice.

Customer Care & Technical Support

Please use the following numbers for speedy assistance.

Ideal Parts..... Tel: 01482 498 665
..... Fax: 01482 498 489

Customer Care & Technical Support.

Scotland/N. England/Midlands..... Tel: 01482 498 636

Southern England/S. Wales..... Tel: 01482 498 660

..... Fax: 01482 498 666

Publications/literature..... Tel: 01482 498 467

CARADON IDEAL Ltd.
P.O. Box 103, National Avenue,
Kingston upon Hull,
North Humberside. HU5 4JN.
Telephone: 01482 492 251
Registration No. London 322 137.
Registered Office; National Avenue, Kingston upon Hull,
North Humberside, HU5 4JN.
A subsidiary of Caradon p.l.c

Fax: 01482 448 858.

BOILERS
Ideal

April 1997 150 942 A01

Printed in England