

User Guide

Gas Fired Wall Mounted Condensing System Boiler

EcoBlue System

12 - 15 - 18 - 24 - 28 - 32

Please keep these instructions in a safe place.
If you move house, please hand them over to the next occupier.

Model Range

Baxi EcoBlue 12 System ErP
G.C.N° 41-070-23
Baxi EcoBlue 15 System ErP
G.C.N° 41-070-24
Baxi EcoBlue 18 System ErP
G.C.N° 41-070-25
Baxi EcoBlue 24 System ErP
G.C.N° 41-070-26
Baxi EcoBlue 28 System ErP
G.C.N° 41-070-27
Baxi EcoBlue 32 System ErP
G.C.N° 41-470-28

Most illustrations in this document show the 12/15/18/24/28 models. Where the detail for 32 model differs it is described in the text or shown in a specific diagram.

Dear Customer,

Thank you for purchasing this appliance.

Please read this manual carefully before using the product and keep it in a safe place for future reference.

In order to ensure continued safe and efficient operation we recommend that the product is regularly maintained. Our Service and After Sales organization can assist with this.

We hope you will receive many years of satisfactory service.



© Baxi Heating UK Ltd 2015 All rights reserved. No part of this publication may be reproduced or transmitted in any form or by any means, or stored in any retrieval system of any nature (including in any database), in each case whether electronic, mechanical, recording or otherwise, without the prior written permission of the copyright owner, except for permitted fair dealing under Copyrights, Designs and Patents Act 1988.

Applications for the copyright owner's permission to reproduce or make other use of any part of this publication should be made, giving details of the proposed use, to the following address:

The Company Secretary, Baxi Heating UK Limited,
Brooks House, Coventry Road, Warwick. CV34 4LL

Full acknowledgement of author and source must be given.

WARNING: Any person who does any unauthorised act in relation to a copyright work may be liable to criminal prosecution and civil claims for damages.

The Benchmark Scheme

Baxi Heating UK Ltd is a licensed member of the Benchmark Scheme which aims to improve the standards of installation and commissioning of domestic heating and hot water systems in the UK and to encourage regular servicing to optimise safety, efficiency and performance.

Benchmark is managed and promoted by Heating and Hotwater Industry Council. For more information visit www.centralheating.co.uk

Contents

1	Introduction	5
1.1	General	5
1.2	Additional Documentation	5
1.3	Symbols Used	5
1.4	Abbreviations / Glossary	6
1.5	Liabilities.....	6
1.5.1	Manufacturer's Liability	6
1.5.2	Installer's Responsibility	7
1.5.3	User's Responsibility	7
2	Safety	8
2.1	General Safety Instructions	8
2.2	Recommendations	9
2.2.1	Benchmark Commissioning Checklist	9
3	Technical Specifications	10
3.1	Technical Data	10
4	Description of the Product	12
4.1	General Description	12
4.2	Operating Principle	12
4.2.1	In Operation	12
4.3	Control Panel Description	13
4.4	Standard Delivery	14
4.5	Accessories & Options	14
4.5.1	Optional Extras	14
5	Operation	15
5.1	Shutdown	15
5.2	Frost Protection	15
5.3	Operation Checking Procedure & Basic Fault Identification	16
6	Settings	18
6.1	Setting the Boiler Temperature	18
6.1.1	Boiler Flow Temperature	18
6.1.2	Inactive Buttons	18
6.1.3	On/Off Selector Button	18
6.1.4	Information Display.....	18
7	Maintenance	19
7.1	General	19
7.2	Maintenance Instructions	19
7.3	Repressurising the System.....	20
7.4	Venting the System	21
7.5	Draining the System	22

8	Troubleshooting	23
8.1	Error Codes	23
8.2	Fault Finding	24
9	Decommissioning	25
9.1	Decommissioning Procedure	25
10	Disposal	25
10.1	Disposal / Recycling	25
11	Environmental	26
11.1	Energy Saving	26
12	Warranty	27
12.1	General	27
12.2	Terms of Warranty	27
12.2.1	Standard Warranty Terms and Conditions	27
13	Appendix	29
13.1	ErP Information	29
13.1.1	Product Fiche - Boiler Space Heaters	29
13.1.2	Package Fiche - Boilers	30

1 Introduction

1.1 General



WARNING

Installation, repair and maintenance must only be carried out only by a competent person. This document is intended for use by competent persons,

All Gas Safe registered engineers carry an ID card with their licence number and a photograph. You can check your engineer is registered by telephoning 0800 408 5500 or online at www.gassaferegister.co.uk

This manual is intended for the user of the Baxi EcoBlue System boiler. If the appliance is sold or transferred, or if the owner moves leaving the appliance behind you should ensure that the manual is kept with the appliance for consultation by the new owner and their installer.

The appliance is designed as a boiler for use in residential domestic environments on a governed meter supply only. The selection of this boiler is entirely at the owner's risk. If the appliance is used for purposes other than or in excess of these specifications, the manufacturer will not accept any liability for resulting loss, damage or injury.

The manufacturer will not accept any liability whatsoever for loss, damage or injury arising as a result of failure to observe the instructions for use, maintenance and installation of the appliance.

1.2 Additional Documentation

Various timers, external controls, etc. are available as optional extras. Full details are contained in the relevant sales literature.

1.3 Symbols Used

In these instructions, various danger levels are employed to draw the user's attention to particular information. In so doing, we wish to safeguard the user's safety, prevent hazards and guarantee correct operation of the appliance.



DANGER

Risk of a dangerous situation causing serious physical injury.



WARNING

Risk of a dangerous situation causing slight physical injury.



CAUTION

Risk of material damage.



Signals important information .



Signals a referral to other instructions or other pages in the instructions.

1.4 Abbreviations / Glossary

- ▶ **DHW:** Domestic hot water
- ▶ **CH:** Central heating
- ▶ **GB:** Great Britain
- ▶ **IE:** Ireland
- ▶ **BS:** British standard
- ▶ **HHIC:** Heating and Hotwater Industry Council
- ▶ **Pnc:** Condensing output

1.5 Extent of Liabilities

1.5.1. Manufacturer's Liability

Our products are manufactured in compliance with the requirements of the various European applicable Directives. They are therefore delivered with **CE** marking and all relevant documentation. In the interest of customers, we are continuously endeavouring to make improvements in product quality. All the specifications stated in this document are therefore subject to change without notice.

The manufacturer will not accept any liability for loss, damage or injury arising as a result of:-

- ▶ Failure to abide by the instructions on using the appliance.
- ▶ Failure to regularly maintain the appliance, or faulty or inadequate maintenance of the appliance.
- ▶ Failure to abide by the instructions on installing the appliance.

This company declares that no substances harmful to health are contained in the appliance or used during appliance manufacture.

The appliance is suitable only for installation in GB and IE and should be installed in accordance with the rules in force, and only used in a suitably ventilated location.

In GB, the installation must be carried out by a Gas Safe Registered Installer. It must be carried out in accordance with the current and relevant requirements of legislation and guidance.

Where no specific instructions are given, reference should be made to the relevant British Standard Code of Practice.

In IE, the installation must be carried out by a competent person and installed in accordance with the current edition of I.S. 813 'Domestic Gas Installations', the current Building Regulations and reference should be made to the current ETCI rules for electrical installation.

Incorrect installation could invalidate the warranty and may lead to prosecution.

1.5.2 Installer's Responsibility

The installer is responsible for the installation and initial start up of the appliance. The installer must adhere to the following instructions:

- ▶ Read and follow the instructions given in the manuals provided with the appliance.
- ▶ Carry out installation in compliance with the prevailing legislation and standards.
- ▶ Ensure the system is flushed and inhibitor added.
- ▶ Install the flue/chimney system correctly ensuring it is operational and complies with prevailing legislation and standards, regardless of location of the boiler's installation.
- ▶ Only the installer should perform the initial start up and carry out any checks necessary.
- ▶ Explain the installation to the user.
- ▶ Complete the Benchmark Commissioning Checklist - this is a condition of the warranty !
- ▶ Warn the user of the obligation to check the appliance and maintain it in good working order.
- ▶ Give all the instruction manuals to the user.

1.5.3. User's Responsibility

To guarantee optimum operation of the installation, you must observe the following instructions:

- ▶ Read and observe the instructions given in the manuals supplied with the appliance.
- ▶ Seek the assistance of a qualified installer for the installation and initial commissioning.
- ▶ Ask the installer to explain the installation.
- ▶ Have the required annual inspection and maintenance carried out by a qualified installer and ensure the Benchmark Service Record in the Installation Manual is completed - this is a condition of the warranty !
- ▶ Keep the manuals in good condition and near to the appliance.

This appliance must not be used by people with a lack of experience or knowledge, unless they are supervised by someone familiar with the appliance or if they have been instructed on how to operate the appliance correctly. Do not allow children to operate or play with the appliance.

2 Safety

2.1 General Safety Instructions

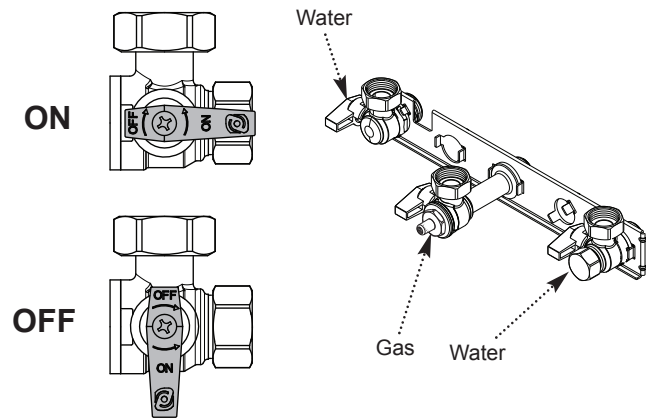

DANGER

If you smell gas:

1. Turn off the gas supply at the meter
2. Open windows and doors in the hazardous area
3. Do not operate light switches
4. Do not operate any electrical equipment
5. Do not use a telephone in the hazardous area
6. Extinguish any naked flame and do not smoke
7. Warn any other occupants and vacate the premises
8. Telephone the National Gas Emergency Service on:- 0800 111 999



If a water or gas leak occurs or is suspected, the boiler can be isolated at the inlet valves by turning their taps through 90° (1/4 turn) downwards

For advice please contact your Installer, Annual Service Provider or **Baxi Customer Support** - The Service Division of Baxi. You can contact **Baxi Customer Support** on telephone number **0344 871 1525**.

When contacting **Baxi Customer Support** it will be useful to have the '**Benchmark Checklist**' at the back of the Installation & Service Manual to hand as it includes details relevant to the boiler and installation.



WARNING

Do not touch flue/chimney pipes. Depending on the settings of the appliance, the temperature of flue/chimney pipes may exceed 60 °C.

Do not touch radiators for long periods. Depending on the settings of the appliance, the temperature of radiators may reach 85 °C.

Take precautions with domestic hot water. Depending on the settings of the appliance, domestic hot water temperature may reach 65 °C.



CAUTION

Do not neglect to service the appliance. Contact a qualified professional or take out a maintenance contract for the annual servicing of the appliance.

2.2 Recommendations



CAUTION

Only qualified professionals are authorised to work on the appliance and the installation.

The appliance has an integral frost protection mode as long as there is power to the boiler.



Regularly check the water pressure in the system (recommended pressure is 1.5 bar).

See section 7.4.

Keep the appliance accessible at all times.

Do not remove or cover the user information and serial number labels affixed to the boiler control flap. They must remain legible throughout the lifetime of the appliance

2.2.1 Benchmark Commissioning Checklist

1. Please ensure that the installer has fully completed the Benchmark Checklist on the inside back pages of the installation instructions supplied with the product and that you have signed it to say that you have received a full and clear explanation of its operation. The installer is legally required to complete a commissioning checklist as a means of complying with the appropriate Building Regulations (England and Wales).
2. All installations must be notified, by the installer, to Local Area Building Control either directly or through a Competent Persons Scheme. A Building Regulations Compliance Certificate will then be issued to the customer who should, on receipt, write the Notification Number on the Benchmark Checklist.
3. This product should be serviced annually to optimise its safety, efficiency and performance. The service engineer should complete the relevant section of the Benchmark Service Record in the Installation & Service manual after each service.
4. The completed Benchmark Checklist & proof of annual servicing (where applicable) will be required in the event of any warranty work.

3 Technical Specifications

3.1 Technical Data 12/15/18/24/28

Central Heating Primary Circuit Pressures

	bar
Safety Discharge	3
Max Operating	2.5
Min Operating	0.5
Recommended Operating Range	1-2

Temperatures

Boiler Flow Temp (adjustable)
25°C to 80°C max (± 5°C)

Electrical Supply 230V~ 50Hz
(Appliance must be connected to an earthed supply)

Electrical Protection
IPX5D (without integral timer)
IP20 (with integral timer)

External Fuse Rating 3A

NOTE: All data in this section are nominal values and subject to normal production tolerances.

Dimensions & Clearances These must be maintained in the event of any alteration in the property, e.g. additional cupboards etc.

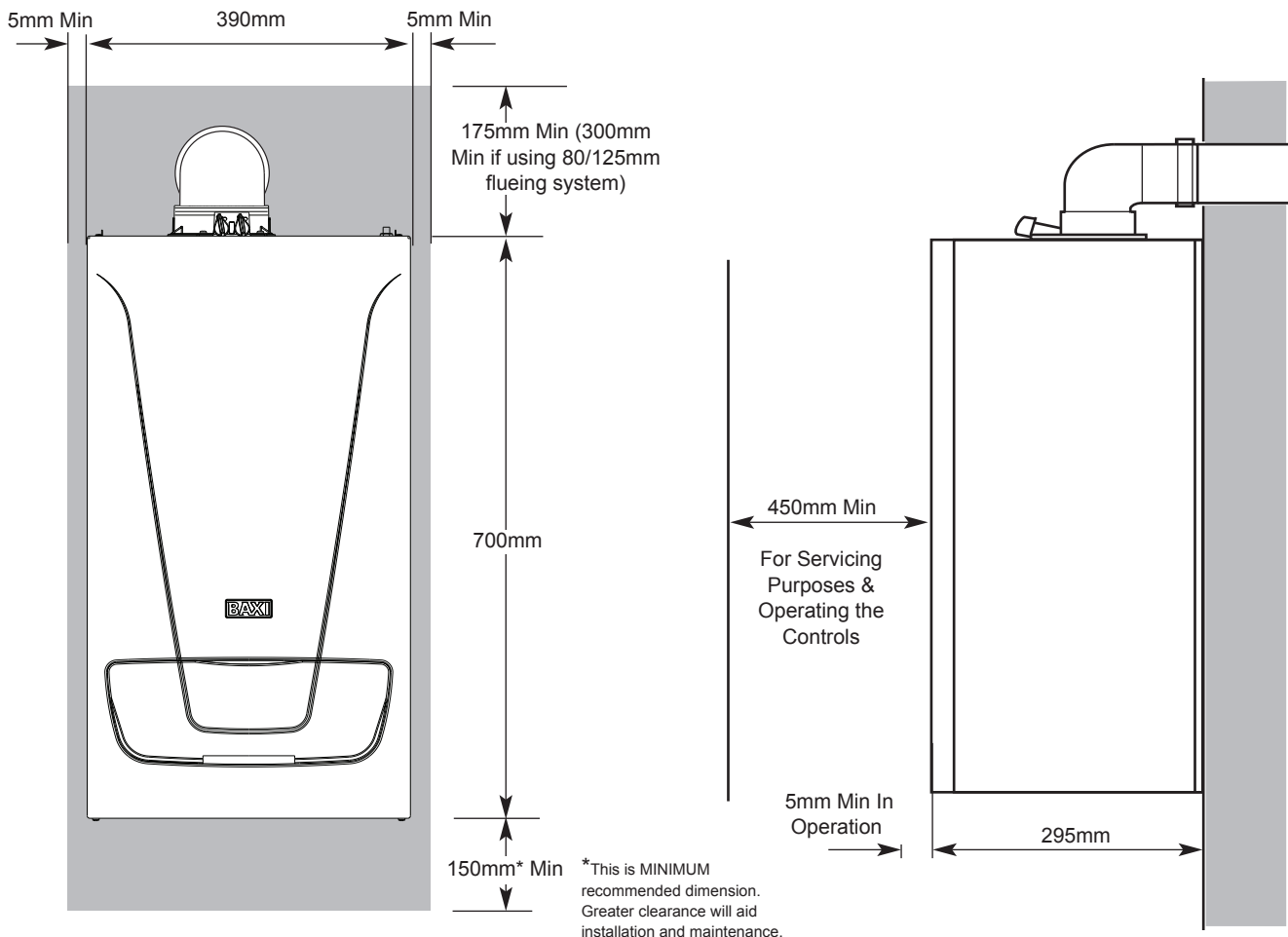

3 Technical Specifications

3.1 Technical Data 32

Central Heating Primary Circuit Pressures

	bar
Safety Discharge	3
Max Operating	2.5
Min Operating	0.5
Recommended Operating Range	1-2

Temperatures

Boiler Flow Temp (adjustable)
25°C to 80°C max (± 5°C)

Electrical Supply 230V~ 50Hz
(Appliance must be connected to an earthed supply)

Electrical Protection
IPX5D (without integral timer)
IPX20 (with integral timer)

External Fuse Rating 3A

NOTE: All data in this section are nominal values and subject to normal production tolerances.

Dimensions & Clearances These must be maintained in the event of any alteration in the property, e.g. additional cupboards etc.

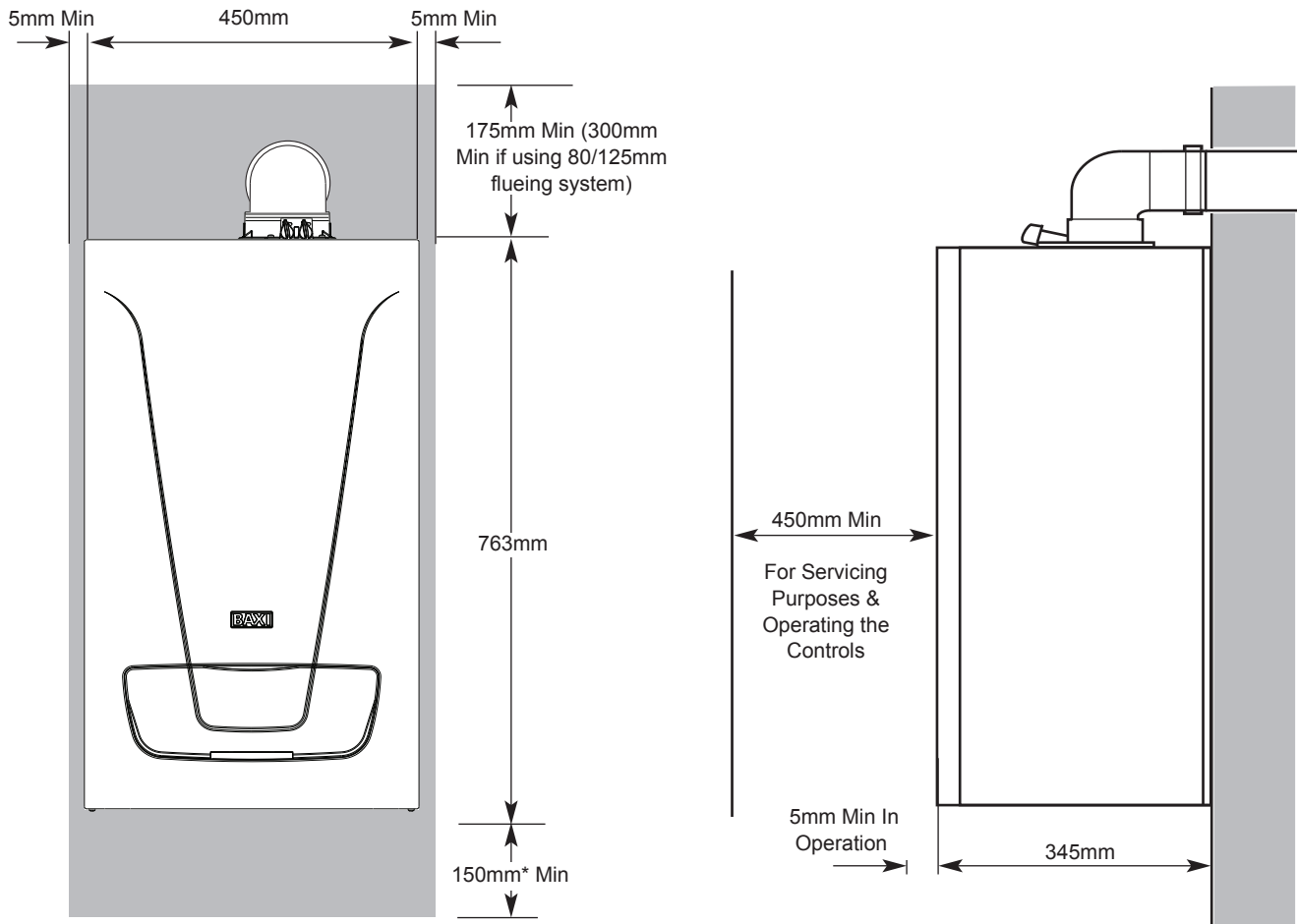

*This is MINIMUM recommended dimension. Greater clearance will aid installation and maintenance.

4 Description of the Product

4.1 General Description

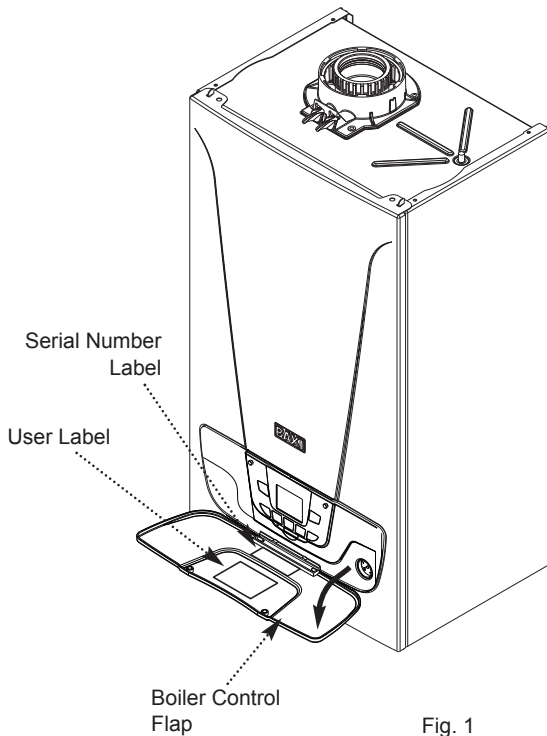

Fig. 1

1. The Baxi EcoBlue System boilers are fully automatic gas fired wall mounted condensing boilers. They are room sealed and fan assisted, and will serve central heating and stored domestic hot water.

2. The boiler is set to give a maximum output of :-

12 model -	12 kW
	12.7 kW Pnc (Condensing)
15 model -	15 kW
	15.9 kW Pnc (Condensing)
18 model -	18 kW
	19 kW Pnc (Condensing)
24 model -	24 kW
	25.4 kW Pnc (Condensing)
28 model -	28 kW
	29.6 kW Pnc (Condensing)
32 model -	32 kW
	33.8 kW Pnc (Condensing)

3. The boiler is factory set for use only on Natural Gas (G20).

4. The boiler model, serial number and Gas Council number are also shown on the information label behind the boiler control flap (Fig. 1). This is for user reference.



The boiler is set by use of the  button - see Section 6.1.

4.2 Operating Principle

4.2.1 In Operation

1. Whilst the boiler is in operation cooled flue gases are discharged through the flue gas discharge pipe. This may appear as a cloud of steam which is normal.

2. Condensed water is discharged from the boiler heat exchanger into a pipe (the condensate drain). This pipe must never be altered or re-routed except by a qualified professional.

4.3 Control Panel Description

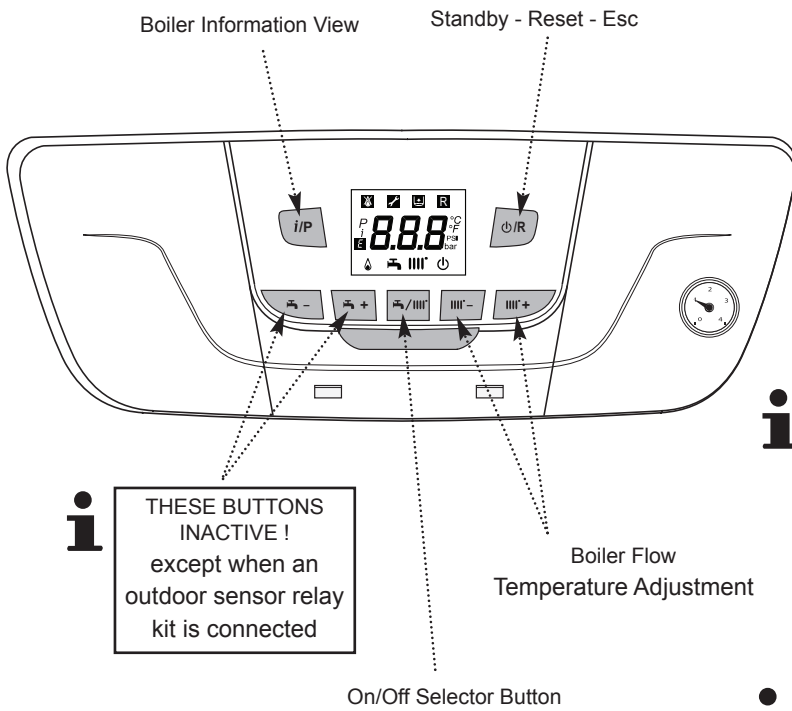

Key to Controls

Standby - Reset - Esc Button

Boiler Information View Button

Increase CH Temperature Button

Decrease CH Temperature Button

Inactive Button Except when an outdoor sensor relay kit is connected

Inactive Button

On/Off Selector Button

When is displayed (Boiler On) the boiler will respond to timed Heating or Hot Water demand.

N.B. If only is displayed the boiler will not operate !

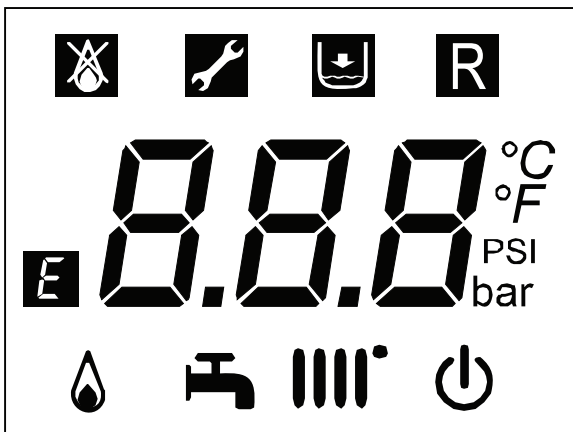

Display showing all available characters

Display Description

- DHW and CH OFF (frost protection still enabled)
- See Section 5.2 for information
- Indicates an error that prevents burner from igniting
- Error - Not resettable by user
- Water pressure too low
- Indicates an error resettable by the user
- Generic error
- Burner lit
- DHW mode (symbol will flash with demand)
- Heating mode (symbol will flash with demand)
- Units for temperature
- Units for temperature
- Units for pressure
- Units for pressure

4.4 Standard Delivery

1. The literature pack contains:

- ▶ Literature pack
 - Installation & Servicing Manual
 - User Guide Instructions
 - Registration Card
 - Envelope
 - Fernox Leaflet
 - Wall Template
 - Product Leaflet
 - Package Leaflet

4.5 Accessories & Options

4.5.1 Optional Extras

1. Various timers, external controls, etc. are available as optional extras.

- ▶ Outdoor Sensor - Wired
- ▶ Mechanical Thermostat
- ▶ Mechanical Timer (24 hr) - Plug-in
- ▶ Digital Timer (7 day) - Plug-in
- ▶ Single Channel Timer - Wired
- ▶ Two Channel Timer - Wired
- ▶ RF Digital Programmable Room Unit - Wireless
- ▶ RF Mechanical Programmable Room Unit - Wireless
- ▶ Condensate Discharge Pump and Pipe 'Trace Heating'
- ▶ Flue Accessories (elbows, extensions, clamps etc.)
(refer to the Flue Installation Guide supplied in the literature pack.)
- ▶ Remote relief valve kit
- ▶ Boiler discharge pump
- ▶ 1M Condensate Drain Pipe 'Trace Heating' Element
- ▶ 2M Condensate Drain Pipe 'Trace Heating' Element
- ▶ 3M Condensate Drain Pipe 'Trace Heating' Element
- ▶ 5M Condensate Drain Pipe 'Trace Heating' Element

Any of the above MUST be fitted ONLY by a qualified competent person. Further details can be found in the relevant sales literature and at www.baxi.co.uk

5 Operation

5.1 Shutdown

1. If it is anticipated that the boiler will not be used for a long period or the property is to be unoccupied it is recommended that the system drained if the electricity & gas supplies are to be turned off. Your installer will be able to offer advice.

5.2 Frost Protection

1. The boiler incorporates an integral frost protection feature that will operate in 'On' mode, and also when in standby mode ( displayed).

2. If the boiler temperature falls below 5°C, then the boiler will operate until the water temperature has been raised.

3. Further protection may be required for the system. Consult your installer for details.

5.3 Operation Checking Procedure & Basic Fault Identification

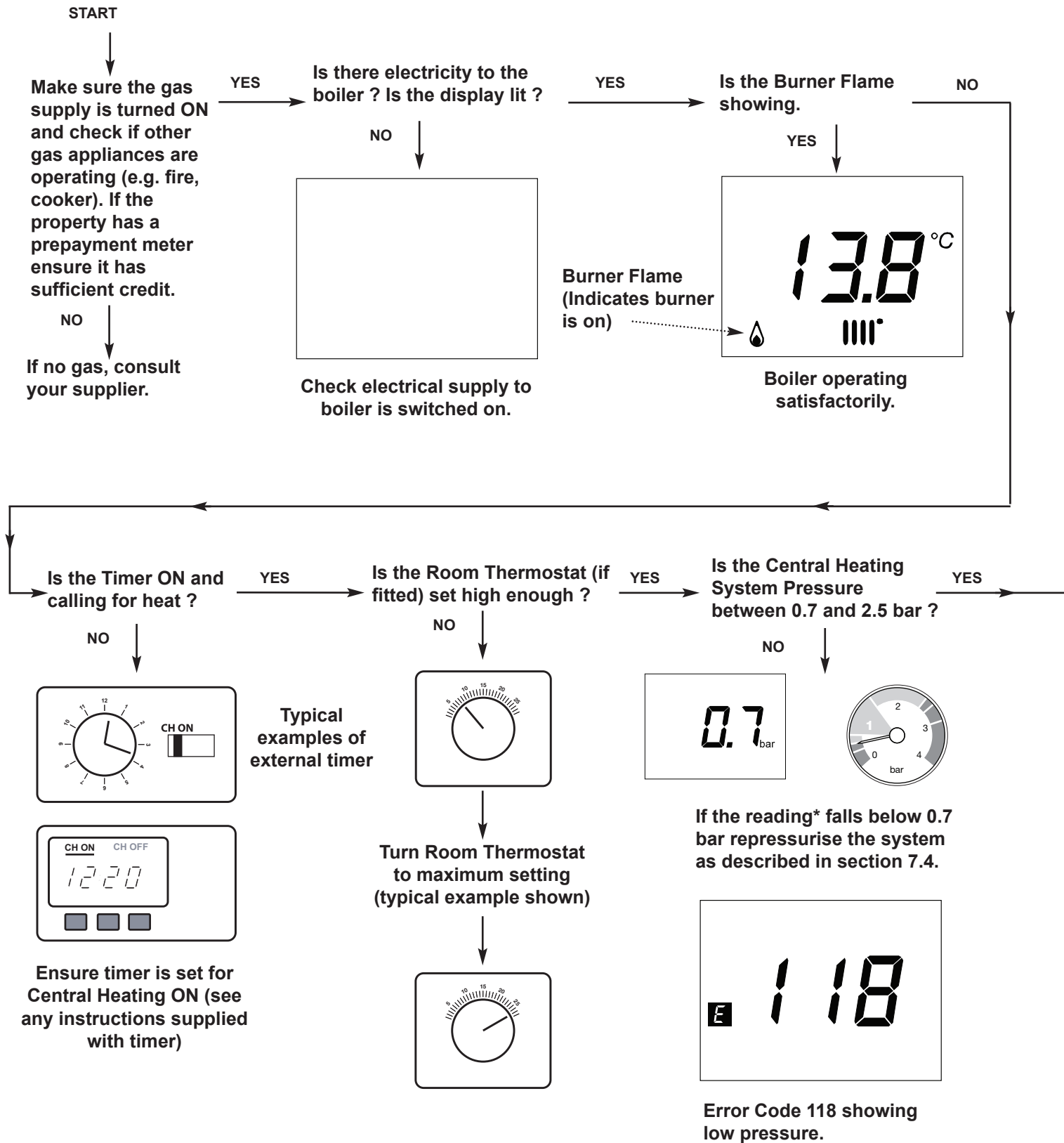

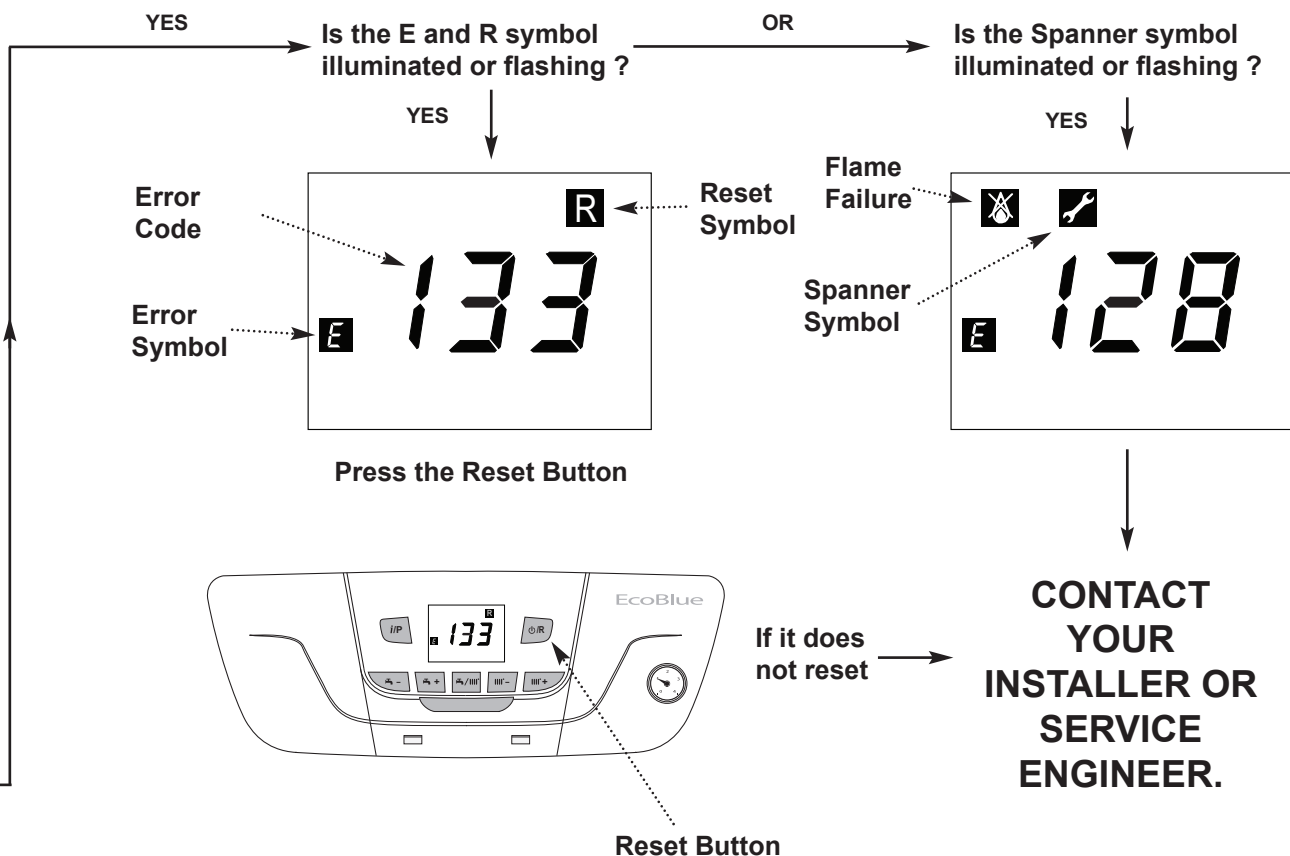

*To display the water pressure press *iP* until *i 05* is shown.

i 05 will alternate with the system pressure.
 (NOTE: When the pump is running the gauge under the boiler may show a slightly different reading to the display)

If you don't know what you need to do to get the boiler to light, or need help with the system and controls, contact your installer as soon as possible

6 Settings

6.1 Setting the Boiler Temperature

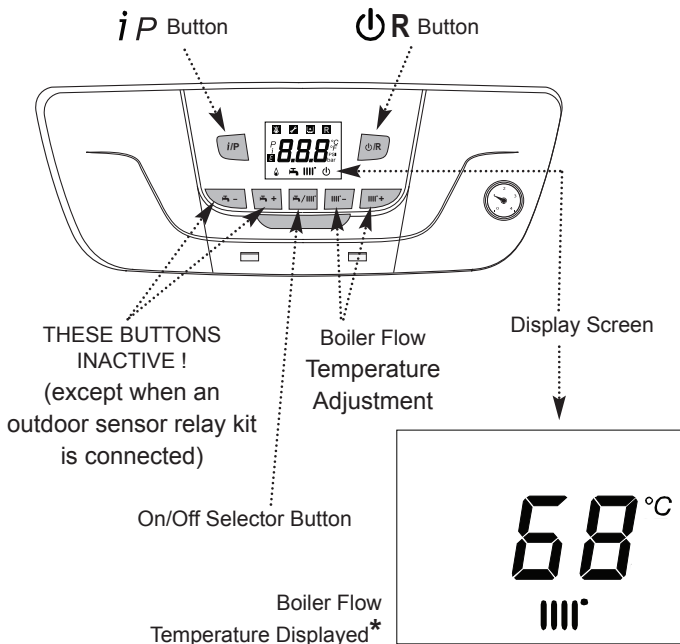

The values displayed are the temperature as measured at the boiler, not necessarily that at the radiator or tap. Because of differences in systems, seasonal variations in mains water temperature etc. some adjustment of the temperatures may be required to achieve the desired results. Your installer will be able to offer advice.

***Where Outdoor Sensor fitted**

If the control system includes an Outdoor Sensor the temperature display and Central Heating buttons perform different functions than those described.

Display - This shows a simulated room temperature set point, NOT the boiler temperature.

Boiler Flow Temperature Buttons - They will alter the displayed temperature, and for optimum use should be used to change the displayed temperature to the same as selected on the room thermostat. By selecting a temperature different to the room thermostat altered comfort levels may be achieved.

Boiler Flow Temperature Buttons - When in DHW mode these buttons are active. The boiler flow temperature set point will be shown on the display - this must be AT LEAST the same temperature as the cylinder thermostat, and can be changed using these buttons.

Your installer will be able to offer advice.

6.1.1 Boiler Flow Temperature

To increase or decrease the boiler temperature:-

1. Press **Boiler Flow Temperature +** to increase the boiler flow temperature.*
2. Press **Boiler Flow Temperature -** to decrease the boiler flow temperature.*

i This sets the temperature at which the heated water flows from the boiler. The temperature of radiators and domestic hot water will depend upon the setting of various controls (e.g. Thermostatic Radiator Valves, cylinder thermostat). Your installer will be able to recommend the optimum boiler temperature setting, according to the controls fitted and your requirements.

i If **Boiler Flow Temperature +** and **Boiler Flow Temperature -** are pressed together P02 will be displayed. Pressing either button again will scroll through the display and P26 & P64 will be shown. Press **On/Off Selector** to return to normal display.

6.1.2 Inactive Buttons*

1. Both **Boiler Flow Temperature +** and **Boiler Flow Temperature -** are inactive unless an outdoor sensor is connected.

6.1.3 On/Off Selector Button

1. Press **On/Off Selector** button until the Boiler On mode symbol appears:-

Boiler On mode symbol

N.B. If only **Boiler On mode** is displayed the boiler will not operate !

Hand icon See 6.1.1 to set the required temperature.

6.1.4 Information Display

1. The table opposite shows information that can be displayed by pressing the **iP** button.
2. Depending upon boiler model and any system controls connected to the appliance, not all information codes will be displayed and some that are will not have a value.
3. Press **On/Off Selector** to return to the normal display.

7 Maintenance

7.1 General

1. The boiler does not require any special maintenance. However, the boiler must be serviced annually in accordance with the Installation and Service Manual and the relevant section of the Benchmark Service Record completed in order to maintain the warranty.



Taking out a maintenance contract is recommended.



CAUTION

Maintenance operations must be performed by a qualified competent person.

Use only genuine spare parts.

2. The painted panels should be wiped with a damp cloth and then dried completely. **DO NOT USE ABRASIVE CLEANING AGENTS.**

7.2 Maintenance Instructions

1. The central heating installation should be checked regularly. Proceed as follows:

- Check the water pressure in the central heating installation.



If the water pressure is lower than 0.7 bar, the water must be topped up. If necessary: top up the CH installation (recommended water pressure between 1 and 1.5 bar when system is cold).

- Check radiators for leaks and (especially in damp areas) for rust.
- Open and close the radiator valves several times a year to ensure they can still be rotated.
- Only clean the outside of the boiler with a damp cloth. Do not use abrasive cleaning agents.



CAUTION

Only a qualified installer may clean the inside of the boiler.

7.3 Re-pressurising the System

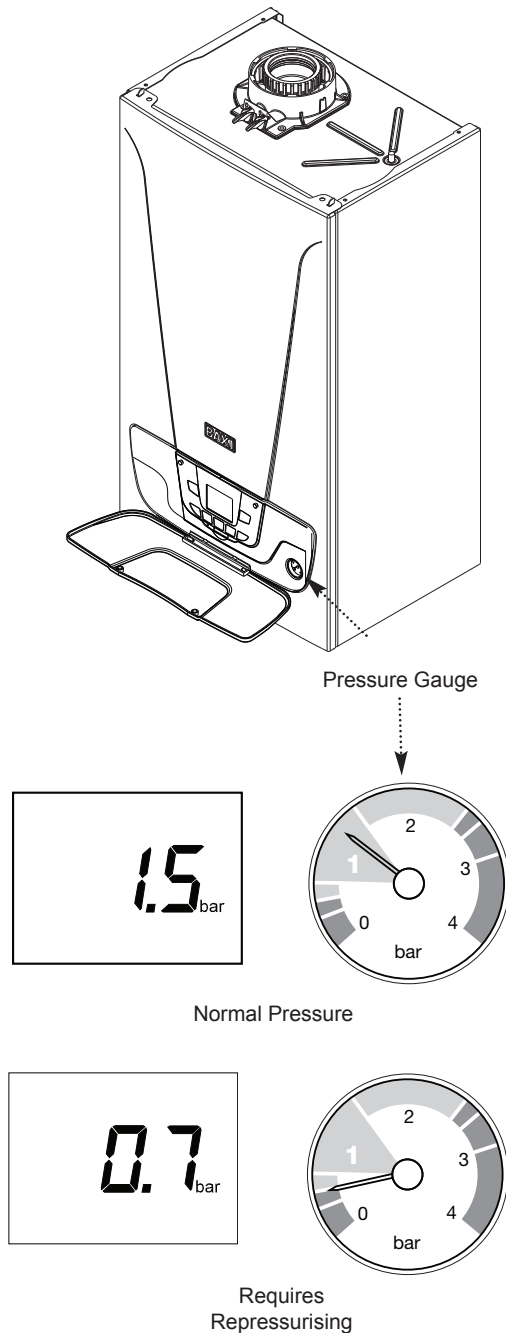

1. If the water pressure is too low, the installation must be re-pressurised.

2. The normal operating water pressure is between 1 and 2 bar. If the pressure exceeds 3 bar the safety pressure valve will operate and a fault is indicated (E117 displayed). Ensure that the filling loop is disconnected. Contact your installer.

3. It may be necessary to repressurise the system occasionally (when the water pressure falls below 0.7 or E118 displayed). A filling device (the filling loop) will be fitted on the system. Normally this will be situated on pipework close to the boiler.

 If the water pressure requires regular re-pressurising a fault or leak is indicated. Seek advice from your installer.

4. If you are unsure of its position, or cannot identify it, consult the installer who fitted the boiler.

5. The filling loop consists of two isolating taps and a separate filling pipe with connection fittings.

6. Only when repressurising should the filling pipe be connected between the two taps. Ensure that the nuts on the pipe ends are tightened onto the taps and the system is cold.

7. Fully open one of the taps first, and then while watching the pressure gauge, carefully open the second tap.

8. The system pressure is shown at all times on the pressure gauge and can be viewed on the display when there is power to the boiler.

9. To check the water pressure on the boiler display press *ip* until *05* is shown. This will alternate with the system pressure. (When the pump is running the pressure gauge may show a slightly different reading to the display).

10. When the figures on the display or needle on the pressure gauge indicate between 1 and 1.5 bar turn both taps off.

11. Disconnect the filling pipe from the taps (a small amount of water may be present) and remove it. Keep the pipe in a safe place for future use.

12. If blanking caps are available fit them to the taps.

 Go to the 'How to videos' section of the 'Information & advice' page at www.baxi.co.uk for further details.

13. When the correct pressure is restored the boiler will reset automatically.

7.4 Venting the System

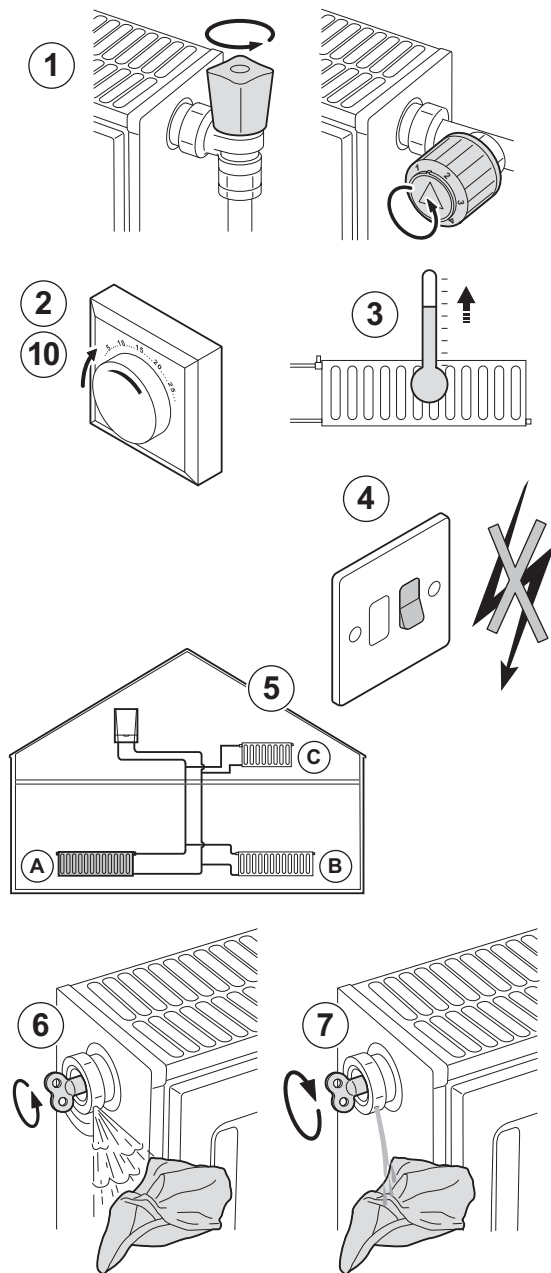

1. If any air is present in the appliance or system it must be removed in order to prevent nuisance noises that may occur during heating or when drawing off hot water. Proceed as follows:

1. Open the valves of all the radiators connected to the system.
2. Set the room thermostat to the highest possible temperature and any timers to 'ON'.
3. Wait until the radiators are warm.
4. Switch off the boiler.
5. Vent the radiators. Work from the lowest radiator in the property.
6. Open the bleed vent with the key, keeping a cloth pressed against the vent.
7. Wait until water comes out of the bleed vent and then close.



WARNING

The CH water in the radiators will still be hot.

8. Switch the boiler on.
9. After venting, check that the water pressure in the system is still adequate.

 If the water pressure is lower than 0.7 bar, the water must be topped up. If necessary repressurise the system (recommended pressure between 1 and 1.5 bar).

10. Reset the room thermostat to the desired temperature.

7.5 Draining the System

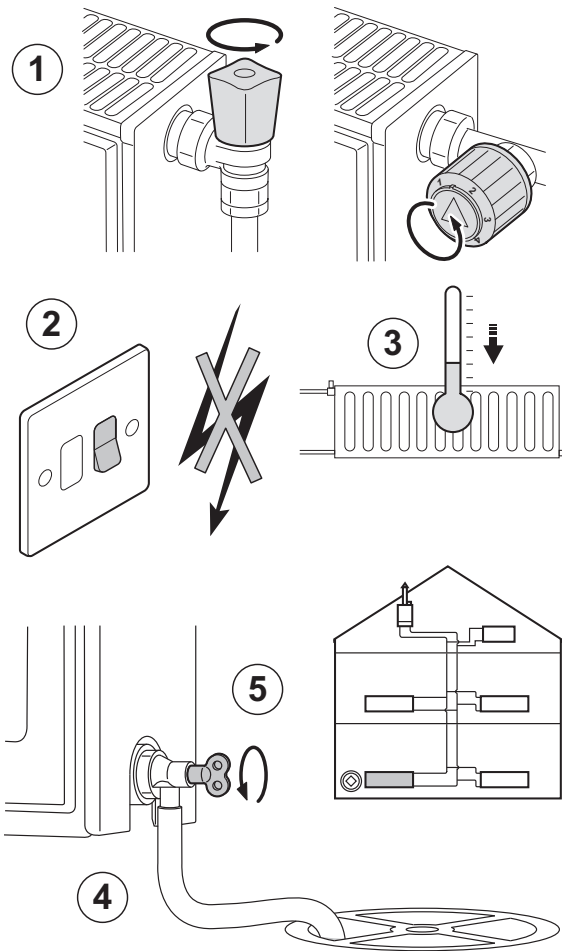

1. It may be necessary to drain the CH system if radiators need to be replaced or removed, if there is a major water leak or if there is a risk of freezing. Proceed as follows:

1. Open the valves of all the radiators connected to the system.
2. Switch off or disconnect the boiler's electrical isolation point (fused spur).
3. Wait until all the radiators are cold.
4. Connect a drain hose to the lowest draining point. Place the end of the hose in a drain or at a place where drained water will not cause any damage.
5. Open the CH system drain valve. Drain the system.



WARNING

The CH water may still be hot.

6. When water stops flowing from the draining point, close the draining valve.



See Sections 7.4 & 7.5 for Re-pressurising & Venting the system. If in doubt seek advice from your installer.



After draining and re-pressurising the concentration of system corrosion inhibitor and anti-freeze may become excessively diluted - seek advice from your installer.

8 Troubleshooting

8.1 Error Codes

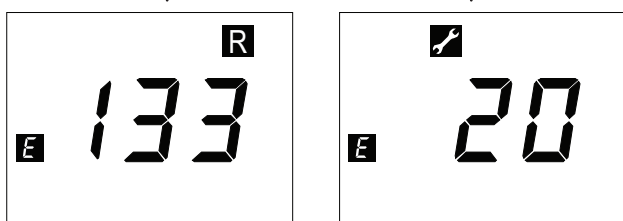
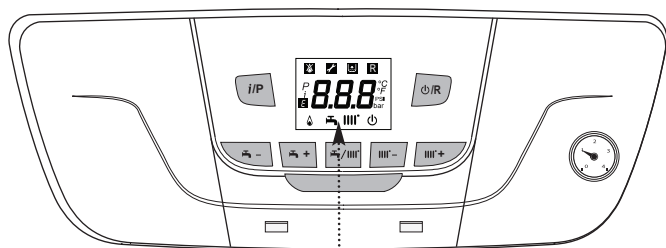

Examples of Error Codes

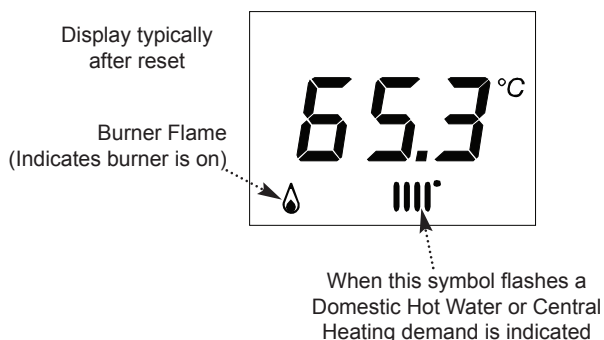

1. In the unlikely event of an error occurring the display will show one of two symbols or **R**. In both cases the display will also show **E** symbol and the numeric value of the error (see the 'Table of Error Codes').

2. When the spanner is displayed the error cannot be reset by the user. Please contact your Installer, Annual Service Provider or **Baxi Customer Support** - The Service Division of Baxi to arrange your Annual Service. You can contact **Baxi Customer Support** on **0344 871 1525**.

When contacting **Baxi Customer Support** it will be useful to have the '**Benchmark Checklist**' at the back of the Installation & Service Manual to hand as it includes details relevant to the boiler and installation.

3. **R** fault errors can be reset by pressing the button and holding for two seconds.

Error Codes 117 and 118 can be reset by restoring the correct system pressure as described in 7.4.

WARNING

If an error code different from those described in the 'Table of Error Codes' appears on the display or a certain fault appears frequently, contact '**Baxi Customer Support**'.

Table Of Error Codes

E 20	Central Heating NTC Fault
E 28	Flue NTC Fault
E 40	Central Heating Return NTC Fault
E 110 R	Safety Thermostat Operated (pump fault)
E 111 R	Safety Thermostat Operated (over temperature)
E 117	Primary System Water Pressure Too High
E 118	Primary System Water Pressure Too Low
E 125 R	Circulation Fault (Primary)
E 128	Flame Failure (no lock-out)
E 130	Flue NTC Operated
E 133 R	Interruption Of Gas Supply or Flame Failure
E 151 R	Flame Failure
E 160 R	Fan or Fan Wiring Fault
E 384	False Flame

8.2 Fault Finding

1. If the boiler is not working also check section 5.3 Operation Checking Procedure & Basic Fault Identification or contact your Installer.

Problem	Possible Causes	Solution
There is no domestic hot water.	The boiler is not working.	Check that the boiler is being supplied with power. Check fuses and the switches. Check whether the gas valve is properly open. If the property has a prepayment meter ensure it has sufficient credit.
	The water pressure is too low (< 0.5 bar).	Re-pressurise the system.
The radiators are cold.	The temperature set point for the heating is too low.	Increase the value with the CH temperature button or if a room thermostat is connected, increase the temperature on the room thermostat.
	The heating mode is deactivated.	Activate the heating mode.
	The radiator valves are not open.	Open the valves of all radiators connected to the system.
	The boiler is not working.	Check that the boiler is being supplied with power. Check fuses and switches. Check whether the gas isolation valve is properly open. If the property has a prepayment meter ensure it has sufficient credit.
The boiler is not working.	The water pressure is too low (< 0.5 bar).	Re-pressurise the system.
	The temperature set point for the heating is too low.	Increase the value with the CH temperature button or if a room thermostat is connected, increase the temperature on the room thermostat.
	No demand for heating.	Ensure that timers & thermostats are calling for heat.
	No power supply.	Check that the boiler is being supplied with power. Check the fuses and switches.
	The boiler is indicating an error.	Press the Reset button  Correct the error, if possible.
	The gas pressure is too low.	Check whether the gas isolation valve is fully open. Open the gas isolation valve.
Condensate drain blocked.	Check drain, especially any external runs in freezing temperatures.	

9 Decommissioning

9.1 Decommissioning Procedure

**CAUTION**

Only qualified professionals are authorised to work on the appliance and installation.

1. If you the boiler needs to be decommissioned either temporarily or permanently the following should be performed:

- Switch off the boiler.
- Switch off the boiler's electrical connection.
- Close the boiler gas valve.
- Drain the CH system.



See section 7.6 Draining the Installation

10 Disposal

10.1 Disposal / Recycling

**WARNING**

Removal and disposal of the boiler must be carried out by a qualified installer in accordance with local and national regulations.

11 Environmental

11.1 Energy Saving

Tips on saving energy:

- ▶ Do not cover radiators. Do not hang curtains in front of radiators.
- ▶ Install reflective panels behind the radiators to prevent heat losses.
- ▶ Insulate the pipes in rooms that are not heated (cellars and lofts).
- ▶ Install loft insulation & double glazing.
- ▶ Use draught excluders where necessary.
- ▶ Upgrade any older boiler external controls.
- ▶ Turn down room thermostats by 1°
- ▶ Close the radiators in rooms not in use.
- ▶ Do not run hot (or cold) water pointlessly.
- ▶ Fit a water-saving shower head to save up to 40 % energy.
- ▶ Take showers rather than baths. A bath consumes twice as much water and energy.

12 Warranty

12.1 General

To make sure your boiler warranty is activated and maintained, it is essential that the:

1. Benchmark checklist is completed by your installer
2. Warranty is registered with Baxi
3. Boiler has an annual service

Please note that failure to adhere to terms and conditions will make your warranty invalid.

12.2 Terms of Warranty

12.2.1 Standard Warranty Terms and Conditions

Warranty Registration, Service & Repair

For full terms and conditions, visit www.baxi.co.uk/terms.

Benchmark Checklist

The Benchmark Checklist will be completed by your installer and records that the boiler has been installed and commissioned correctly. It can be found at the back of the installation and service manual and should be kept in a safe place for the life of the boiler. We will check that the Benchmark Checklist has been completed on an in-warranty visit.

Ways to register your warranty

If your boiler is eligible for an extended warranty, your installer may register the product on your behalf and provide you with the relevant documentation. Please check with your installer.

Should this not be the case, you can register your warranty online at www.baxi.co.uk/registration

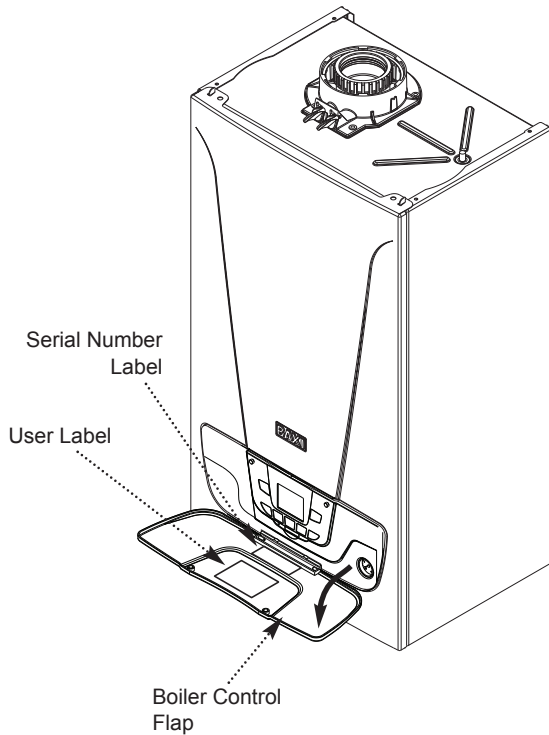

Annual Service

A service must be completed every 12 months from the date of installation to maintain your warranty.

This service must be completed by one of the following:

- A Gas Safe registered installer/engineer
- Baxi Customer Support; call us 0344 871 1525

Please make sure that your engineer has logged the service information at the back of the installation and service manual. You will be asked for your service history on any in-warranty repair visit.

If you experience a problem with your boiler

For any in or out of warranty repair, Baxi Customer Support is on hand to help you. Call our award-winning team to arrange for one of our nationwide team of Gas Safe registered engineers to visit.

If your product is in warranty, everything is free of charge, subject to our warranty terms and conditions. If it is out of warranty, we can still help and offer a range of options you can choose from to suit your needs.

Contact Baxi Customer Support 0344 871 1525

Opening hours

Monday - Friday, 8.00am - 6.00pm

Weekends and Bank Holidays, 8.30am - 2.00pm

Please note calls may be recorded for training and monitoring purposes.

When contacting Baxi Customer Support, please have the following information to hand:

- Boiler serial number. This can be found on the appliance.
- Proof of purchase if you do not have the boiler serial number.

Please note that for in-warranty repairs, our engineers will ask to see your service history record, completed Benchmark Checklist and details of your installer. These can all be found in the installation and user manual.

13 Appendix

13.1 ErP Information

13.1.1. Product Fiche - Boiler Space Heaters

Product fiche for boiler space heaters

Baxi EcoBlue System ErP		12	15	18	24	28	32
Seasonal space heating energy efficiency class		A	A	A	A	A	A
Rated heat output (<i>Prated or Psup</i>)	kW	12	15	18	24	28	32
Seasonal space heating energy efficiency	%	93	93	93	93	93	93
Annual energy consumption	kWh	10323	12903	15484	20645	24086	27527
	GJ	37	46	56	74	87	99
Sound power level L_{WA} indoors	dB	55	55	56	53	56	59



See

For specific precautions about assembling, installing and maintaining, consult the relevant section as detailed on the Contents page.

13.1.2. Package Fiche - Boilers

Package fiche for boilers indicating the space heating energy efficiency of the package

Seasonal space heating energy efficiency of boiler

①
I' %

Temperature control

from fiche of temperature control

Class I = 1%, Class II = 2%, Class III = 1.5%,
 Class IV = 2%, Class V = 3%, Class VI = 4%,
 Class VII = 3.5%, Class VIII = 5%

②
 + %

Supplementary boiler

from fiche of boiler

Seasonal space heating energy efficiency (in %)

③
 $(\text{ } - \text{'I'}) \times 0.1 = \pm \text{ } \%$

Solar contribution

from fiche of solar device

Collector size (in m²)

Tank volume (in m³)

Collector efficiency (in %)

Tank rating ⁽¹⁾
 A* = 0.95, A = 0.91,
 B = 0.86, C = 0.83,
 D - G = 0.81

④
 $(\text{'III'} \times \text{ } + \text{'IV'} \times \text{ }) \times 0.9 \times (\text{ } / 100) \times \text{ } = + \text{ } \%$

(1) If tank rating is above A, use 0.95

Supplementary heat pump

from fiche of heat pump

Seasonal space heating energy efficiency (in %)

⑤
 $(\text{ } - \text{'I'}) \times \text{'II'} = + \text{ } \%$

Solar contribution AND Supplementary heat pump

select smaller value

⑥
 $0.5 \times \text{ } \text{ OR } 0.5 \times \text{ } = - \text{ } \%$

Seasonal space heating energy efficiency of package

⑦
 %

Seasonal space heating energy efficiency class of package

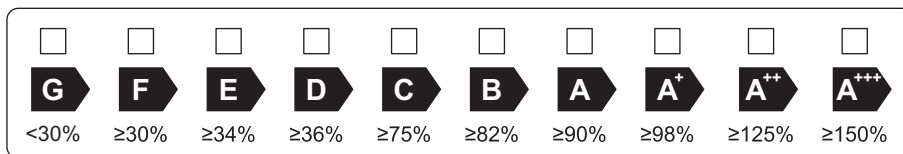

Boiler and supplementary heat pump installed with low temperature heat emitters at 35°C ?

from fiche of heat pump

⑦
 $\text{ } + (50 \times \text{'II'}) = \text{ } \%$

The energy efficiency of the package of products provided for in this fiche may not correspond to its actual energy efficiency once installed in a building, as this efficiency is influenced by further factors such as heat loss in the distribution system and the dimensioning of the products in relation to building size and characteristics.

AD-3000743-01

- I The value of the seasonal space heating energy efficiency of the preferential space heater, expressed in %.
- II The factor for weighting the heat output of preferential and supplementary heaters of a package as set out in the following table.

13.1.2. Package Fiche - Boilers (cont)

- III The value of the mathematical expression: $294/(11 \cdot \text{Prated})$, whereby 'Prated' is related to the preferential space heater.
- IV The value of the mathematical expression $115/(11 \cdot \text{Prated})$, whereby 'Prated' is related to the preferential space heater.

Weighting of boilers

$\text{Psup} / (\text{Prated} + \text{Psup})^{(1)(2)}$	II, package without hot water storage tank	II, package with hot water storage tank
0	0	0
0.1	0.3	0.37
0.2	0.55	0.70
0.3	0.75	0.85
0.4	0.85	0.94
0.5	0.95	0.98
0.6	0.98	1.00
≥ 0.7	1.00	1.00

(1) The intermediate values are calculated by linear interpolation between the two adjacent values.
(2) Prated is related to the preferential space heater or combination heater.

Package efficiency

Baxi EcoBlue System ErP		12	15	18	24	28	32
Temperature control X	%						
Temperature control Y	%						

Baxi Customer Support



0344 871 1525

Opening hours

Monday - Friday, 8.00am-6.00pm

Weekends and Bank Holidays, 8.30am-2.00pm

Please note calls may be recorded for training and monitoring purposes



baxi.co.uk

Register now to activate your warranty:

www.baxi.co.uk/registration

For the warranty to be maintained, please make sure...

- 1** Benchmark checklist is completed
- 2** Warranty is registered with Baxi
- 3** The boiler has an annual service

For full terms and conditions, visit www.baxi.co.uk/terms. Failure to adhere to terms and conditions will void your manufacturer's warranty.



Baxi
Brooks House,
Coventry Road,
Warwick, CV34 4LL



Please ensure the boiler is installed in accordance with these installation instructions and that you adhere to the Building Regulations.

e&oe

All descriptions and illustrations provided in this document have been carefully prepared but we reserve the right to make changes and improvements in our products which may affect the accuracy of the information contained in this leaflet. All goods are sold subject to our standard Conditions of Sale which are available on request.

CE
0086



BAXI