

# **BAXI**

## Installation & Servicing Instructions

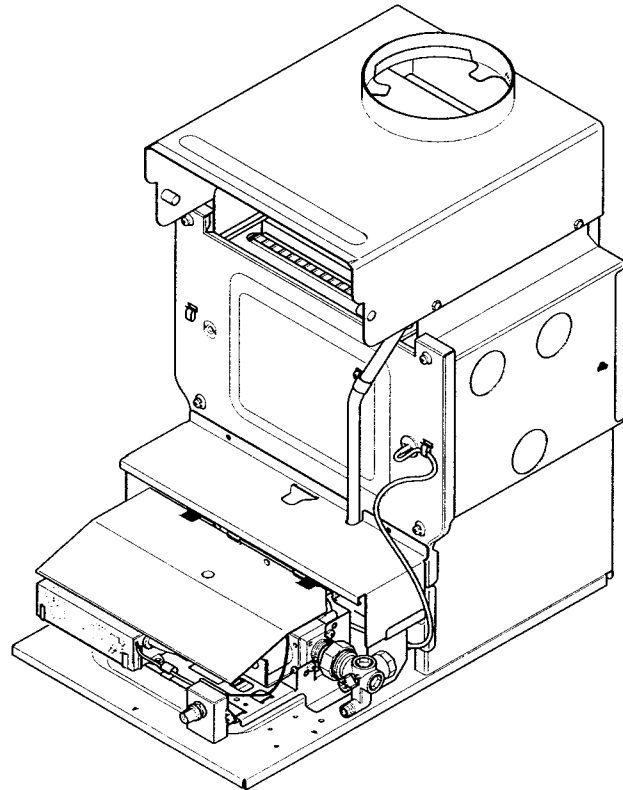

### **Baxi Bermuda 5 1/5 Boiler**

### Fireside Gas Central Heating Unit

These Instructions must be read in conjunction with those for the separate Firefront.

## Natural Gas

---

**Baxi Bermuda 51/5 Boiler**  
G.C.No. 44 075 06

For use with the following firefronts:

**Baxi Bermuda C5**  
G.C.No. 37 077 65  
**Baxi Bermuda C5W Oak**  
G.C.No. 37 077 66  
**Baxi Bermuda C5W Mahogany**  
G.C.No. 37 077 67  
**Baxi Bermuda PW5 Deluxe**  
G.C.No. 37 077 68  
**Baxi Bermuda LFE5 Super**  
G.C.No. 37 077 61  
**Baxi Bermuda GF3 Super**  
G.C.No. 37 077 59  
**Baxi Bermuda VP3**  
G.C.No. 37 077 62  
**Baxi Bermuda SP3**  
G.C.No. 37 077 63  
**Baxi Bermuda SL3**  
G.C.No. 37 077 60  
**Baxi Bermuda RG3**  
G.C.No. 37 077 64

**Baxi Bermuda C5 Renewal**  
G.C.No. 37 075 07A  
**Baxi Bermuda C5W Oak Renewal**  
G.C.No. 37 075 08A  
**Baxi Bermuda C5W Mahogany Renewal**  
G.C.No. 37 075 09A  
**Baxi Bermuda PW5 Deluxe Renewal**  
G.C.No. 37 075 10A  
**Baxi Bermuda LFE5 Super Renewal**  
G.C.No. 37 075 03A  
**Baxi Bermuda GF3 Super Renewal**  
G.C.No. 37 075 01A  
**Baxi Bermuda VP3 Renewal**  
G.C.No. 37 075 04A  
**Baxi Bermuda SP3 Renewal**  
G.C.No. 37 075 05A  
**Baxi Bermuda SL3 Renewal**  
G.C.No. 37 075 02A  
**Baxi Bermuda RG3 Renewal**  
G.C.No. 37 075 06A

Baxi is one of the leading manufacturers of domestic heating products in the UK.

Our first priority is to give a high quality service to our customers. Quality is built into every Baxi product - products which fulfil the demands and needs of customers, offering choice, efficiency and reliability.

To keep ahead of changing trends, we have made a commitment to develop new ideas using the latest technology - with the aim of continuing to make the products that customers want to buy.

Everyone who works at Baxi has a commitment to quality because we know that satisfied customers mean continued success.

We hope you get a satisfactory service from Baxi. If not, please let us know.

## Building Regulations and the Benchmark Commissioning Checklist

Building Regulations (England & Wales) require notification of the installation of a heating appliance to the relevant Local Authority Building Control Department. From 1 April 2005 this can be achieved via a Competent Persons Self Certification Scheme as an option to notifying the Local Authority directly. Similar arrangements will follow for Scotland and will apply in Northern Ireland from 1 January 2006.

CORGI operate a Self Certification Scheme for gas heating appliances.

These arrangements represent a change from the situation whereby compliance with Building Regulations was accepted as being demonstrated by completion of the Benchmark Logbook (which was then left on site with the customer).

With the introduction of Self Certification Schemes, the Benchmark Logbook is being withdrawn. However, a similar document in the form of a commissioning checklist and service interval record is incorporated at the back of these instructions.

Potterton is a member of the Benchmark initiative and fully supports the aims of the programme. Its aim is to improve the standards of installation and commissioning of central heating systems in the UK and to encourage the regular servicing of all central heating systems to ensure safety and efficiency.

Building Regulations require that installations should comply with manufacturer's instructions. It is therefore important that the commissioning checklist is completed by the installer. The relevant section of Building Regulations only relates to dwellings. Therefore the checklist only applies if the appliance is being installed in a dwelling or some related structure.

The flowchart opposite gives guidance for installers on the process necessary to ensure compliance with Building Regulations.

The boiler meets requirements of Statutory Instrument "The Boiler (Efficiency) Regulations 1993 N° 3083" and is deemed to meet the requirements of Directive 92/42/EEC on the energy efficiency requirements for new hot water boilers fired with liquid or gaseous fuels:-

Type test for purpose of Regulation 5 certified by:  
Notified Body 0087.

Product/Production certified by:  
Notified Body 0086.

For GB / IE only.



Baxi is a BS-EN ISO 9001  
Accredited Company

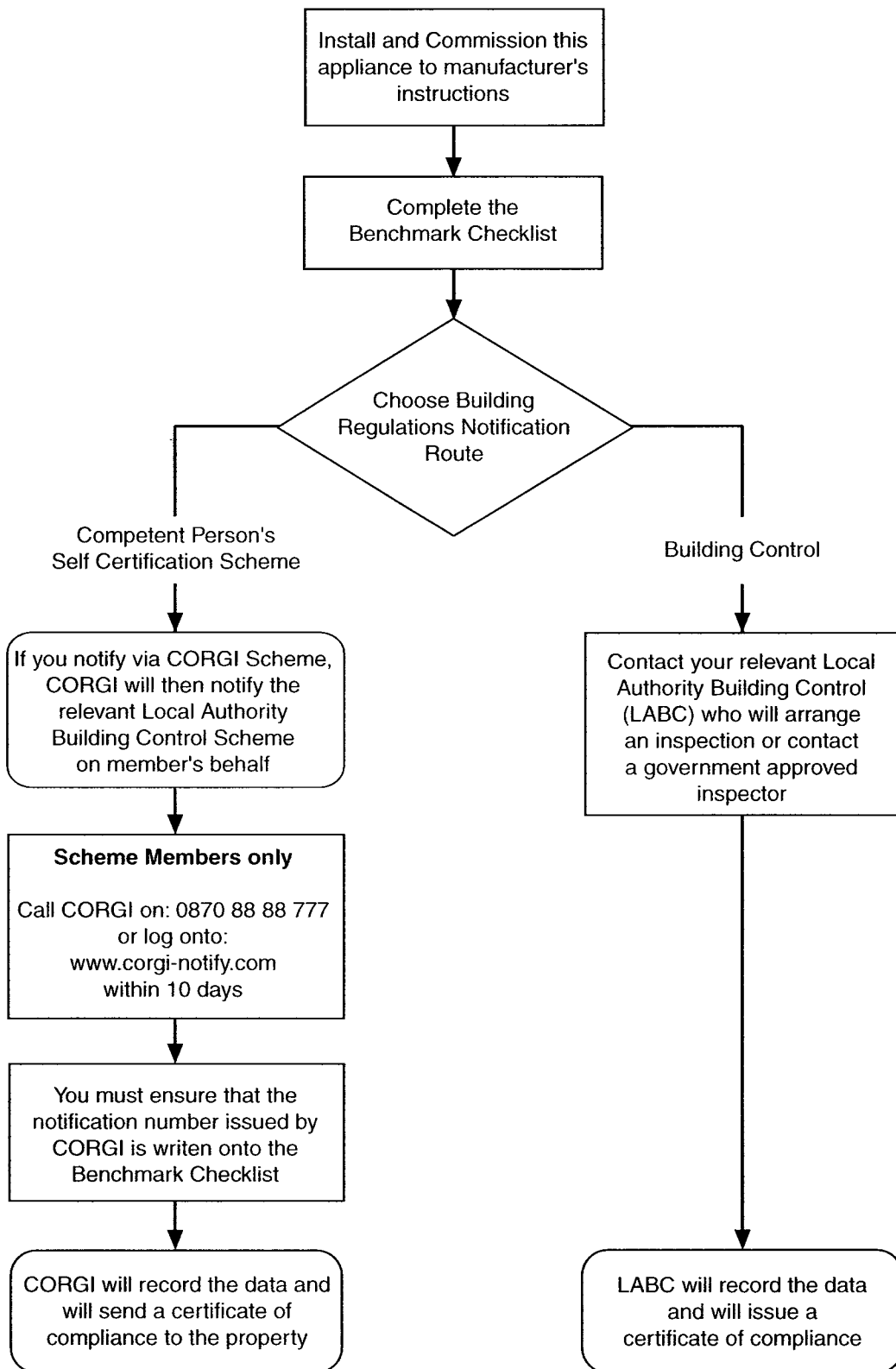

### **IMPORTANT** - Installation, Commissioning, Service & Repair

This appliance must be installed in accordance with the manufacturer's instructions and the regulations in force. Read the instructions fully before installing or using the appliance.

In GB, this must be carried out by a competent person as stated in the Gas Safety (Installation & Use) Regulations.

**Definition of competence:** A person who works for a CORGI registered company and holding current certificates in the relevant ACS modules, is deemed competent.

In IE, this must be carried out by a competent person as stated in I.S. 813 "Domestic Gas Installations".

**Lifting** - This product should be lifted and handled by two people. Stooping should be avoided and protective equipment worn where necessary. Carrying & lifting equipment should be used as required, e.g. when installing on another floor.

The addition of anything that may interfere with the normal operation of the appliance without express written permission from the manufacturer or his agent could invalidate the appliance warranty. In GB this could also infringe the Gas Safety (Installation and Use) Regulations.

**Warning** - Check the information on the data plate is compatible with local supply conditions.

All CORGI registered installers carry a CORGI identification card and have a registration number. You can check your installer is registered by telephoning 0870 4012300 or writing to:-

1 Elmwood,  
Chineham Business Park,  
Crockford Lane,  
Basingstoke. RG24 8WG

or check online at [www.corgi-gas-safety.com](http://www.corgi-gas-safety.com)

**Baxi declare that no substances harmful to health are contained in the appliance or used during appliance manufacture.**

**The appliance is suitable only for installation in GB and IE and should be installed in accordance with the rules in force, and only used in a suitably ventilated location.**

In GB, the installation must be carried out by a CORGI Registered Installer. It must be carried out in accordance with the relevant requirements of the:

- Gas Safety (Installation & Use) Regulations.
- The appropriate Building Regulations either The Building Regulations, The Building Regulations (Scotland), Building Regulations (Northern Ireland).
- The Water Fittings Regulations or Water Byelaws in Scotland.
- The Current I.E.E. Wiring Regulations.

Where no specific instructions are given, reference should be made to the relevant British Standard Code of Practice.

In IE, the installation must be carried out by a competent Person and installed in accordance with the current edition of I.S. 813 'Domestic Gas Installations', the current Building Regulations and reference should be made to the current ETCI rules for electrical installation.

**All systems must be thoroughly flushed and treated with inhibitor (see section 3.2).**

**Codes of Practice**, most recent version should be used

**In GB the following Codes of Practice apply:**

Standard	Scope
BS 689	Gas Installation.
BS 5546	Installation of hot water supplies for domestic purposes.
BS 5449	Forced circulation hot water systems.
BS 6798	Installation of gas fired hot water boilers.
BS 5440 Part 1	Flues.
BS 5440 Part 2	Ventilation.
BS 5871 Part 1	Installation of fire/back boilers, gas appliances.
BS 6500	Cables

**In IE the following Codes of Practice apply:**

Standard	Scope
I.S. 8:3	Domestic Gas Installations.
The following BS standards give valuable additional information:	
BS 5546	Installation of hot water supplies for domestic purposes.
BS 5449	Forced circulation hot water systems.

# Contents

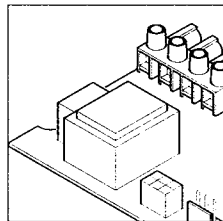
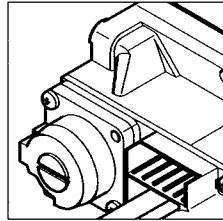
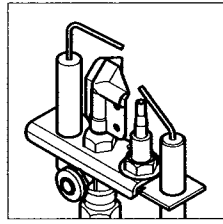

Section	Page
<b>1.0 Introduction</b>	<b>6</b>
<b>2.0 Technical Data</b>	<b>7</b>
<b>3.0 System Details</b>	<b>8</b>
Water Circulating Systems	
Treatment of Water Circulating Systems	
Pipework	
System Controls	
Fully Pumped Open Vent System	
Storage Systems	
Pumped Heating & Gravity Hot Water	
Sealed Systems	
<b>4.0 Site Requirements</b>	<b>12</b>
Builders Opening	
Location	
Fireplace Opening & Surround	
Frame Extension Kit	
Flue	
Ventilation	
Gas Supply	
Electrical Supply	
<b>5.0 Electrical</b>	<b>15</b>
<b>6.0 Installation</b>	<b>16</b>
Initial Preparation	
Right Hand Water Connections	
Connecting the Sensing Pipe	
Fitting the Boiler Hood	
Siting the Boiler	
Securing the Boiler	
Water Connections	
Fully Pumped Systems	
Pumped Heating & Gravity Hot Water	
Gas Connection	
Electrical Connection	
Making the Electrical Connection	
Flue Connection	
Completion	
<b>7.0 Commissioning the Appliance</b>	<b>21</b>
<b>8.0 Annual Servicing</b>	<b>23</b>
Annual Servicing	
Removal of Firefront	
Removal of Controls	
Cleaning the Lint Arrestor	
Cleaning the Burner & Main Injector	
Cleaning the Pilot/A.S.D. Assembly	
Cleaning the Heat Exchanger	
<b>9.0 Changing Components</b>	<b>26</b>
Changing Components	
Removal of Firefront	
Lint Arrestor	
Thermostat Sensor	
Thermostat Potentiometer	
Printed Circuit Board	
Removal of Controls	
Gas Valve	
Burner & Main Injector	
Pilot/A.S.D. Assembly	
Ignition Lead	
<b>10.0 Fault Finding</b>	<b>30</b>
<b>11.0 Short Parts List</b>	<b>33</b>
<b>Benchmark Checklist</b>	<b>34</b>

## 1.0 Introduction

---

### 1.1 Description

1. The Baxi Bermuda is a combined central heating boiler and gas fire designed for installation within a builders opening in the living space of a dwelling.

2. These instructions relate to the central heating boiler section of the appliance (Fig. 1).

3. The boiler output will automatically modulate between:

Max	Min
15.0kW	7.5kW
51,180 Btu/h	25,590 Btu/h

4. The appliance is designed for use on NATURAL GAS only. The boiler is suitable for fully pumped and pumped central heating with gravity hot water systems.

5. It can be used on sealed or open vented systems.

---

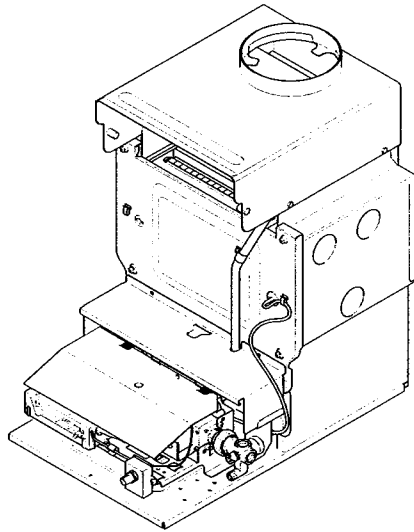
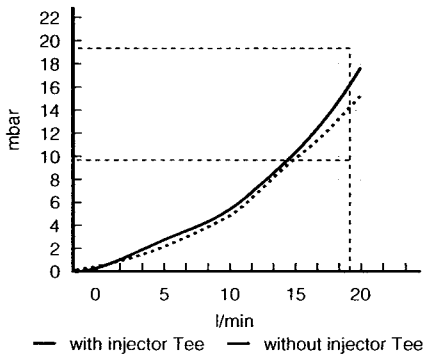

Fig. 1

## 2.0 Technical Data

### Bermuda 51/5 hydraulic resistance



#### Sedbuk Declaration For Bermuda 51/5 Boiler

The seasonal efficiency (SEDBUK) is 78%

This value is used in the UK Government's Standard Assessment Procedure (SAP) for energy rating of dwellings. The test data from which it has been calculated has been certified by 0087.

Appliance Type	B <sub>11AS</sub>		
Appliance Category	Cat I <sub>2H</sub>		
Heat Input (Gross)	Max	Min	
	kW	18.6	9.3
	Btu/h	63,460	31,730
Heat Output	Max	Min	
	kW	15.0	7.5
	Btu/h	51,180	25,590
Pilot Burner	9410		
Heat Input (Gross)	210W (715 Btu/h)		
Burner Pressure	Max	Min	
	mbar (± 1)	16	(Factory Set)
	in wg (± 0.4)	6.4	
Injector	B51		
Water Content	Max		
	litres	2.0	
Gas Connection	R <sub>c</sub> / ( / in BSPT)		
Water Connections	3 × 1 in BSP		
Electricity Supply	230V ~ 50Hz		
	External fuse - 5 Amp Appliance Rating - 17 watt		
Controls	Electronic thermostat intermittent pilot & timed electronic flame sensing with atmospheric sensing device.		
Gas Rate	1.78m <sup>3</sup> /h		
	(after 10 mins)	(62.94ft <sup>3</sup> /h)	
Lifting Weight	38 kg		
Packed Weight	41 kg		
Dimensions	Height	530mm	
	Width	338mm	
	Depth	483mm	
Flue Diameter	125mm		
Heat Exchanger	Cast Iron		
Low Head	(Min)		
	mm	1000	
Water Systems	Fully pumped or pumped heating with gravity hot water. Sealed or open vented systems.		

## 3.0 System Details

### 3.1 Water Circulating Systems

1. The appliance is suitable for use on open vented gravity domestic hot water/pumped central heating systems or fully pumped systems which may be sealed or open vented.

2. The following conditions should be observed at all times:

- The static head must not exceed 30m (100ft) of water.
- The boiler must not be used with a direct cylinder.
- Drain cocks should be fitted to all system low points.
- All gas and water pipes and electrical wiring must be installed in such a way that they do not restrict the servicing of the boiler.
- Position isolating valves as close as possible to the circulating pump.

### 3.2 Treatment of Water Circulating Systems

All recirculatory water systems will be subject to corrosion unless they are flushed and an appropriate water treatment is applied. To prevent this, follow the guidelines given in BS 7593 "Treatment of Water in Domestic Hot Water Central Heating Systems" and the treatment manufacturers instructions.

Treatment must involve the use of a proprietary cleanser, such as BetzDearborn Sentinel X300 or X400, or Femox Superloc and an inhibitor such as BetzDearborn Sentinel X100 or Femox MB-1 or Copal.

Full instructions are supplied with the products, for further information contact BetzDearborn (+44 (0)151 420 9563) or Femox (+44 (0)1799 550811).

**Failure to flush and add inhibitor to the system may invalidate the appliance warranty.**

It is important to check the inhibitor concentration after installation, system modification and at every service in accordance with the inhibitor manufacturer's instructions. (Test kits are available from inhibitor stockists.)

For information or advice regarding any of the above contact the Technical Enquiries 08706 049 049.



## 3.0 System Details

### 3.3 Pipework

1. The sizes of the flow and return pipes from the boiler should be determined by normal methods according to the requirements of the system.
2. It is recommended that the system is designed for an 11°C (20°F) drop in temperature across the system.
3. In systems using non-metallic pipework it is necessary to use copper pipe for the boiler Flow and Return. The copper must extend at least 1 metre from the boiler and include any branches. The copper pipe must not be insulated (Fig. 2).

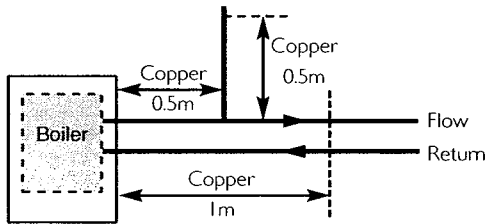

Fig. 2

### 3.4 System Controls

1. The system in which the appliance is installed should include a control system.
2. Such a system would comprise a timer control and a separate room and/or cylinder thermostat as appropriate.
3. The boiler should be controlled so that it operates on demand only.

### 3.5 Fully Pumped Open Vent System (Fig. 3)

1. The sizes of the system pipes should be determined by normal methods.
2. The open vent pipe should be a minimum of 22mm and must rise continuously to a point above the feed and expansion tank.
3. The flow pipe from the boiler may form part of the vent pipe. No part of the open vent should contain a valve.

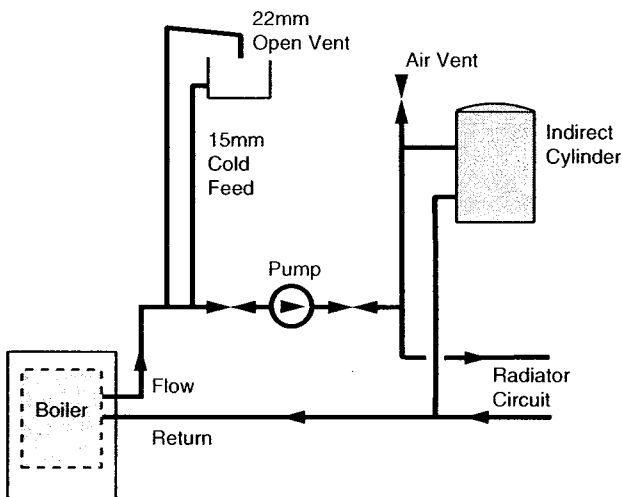

Fully Pumped System

Fig. 3

### 3.6 Storage Systems

1. For information regarding the use of a Bermuda boiler with a storage system, contact the appropriate storage system manufacturer.

## 3.0 System Details

### 3.7 Pumped Heating & Gravity Hot Water (Fig. 4)

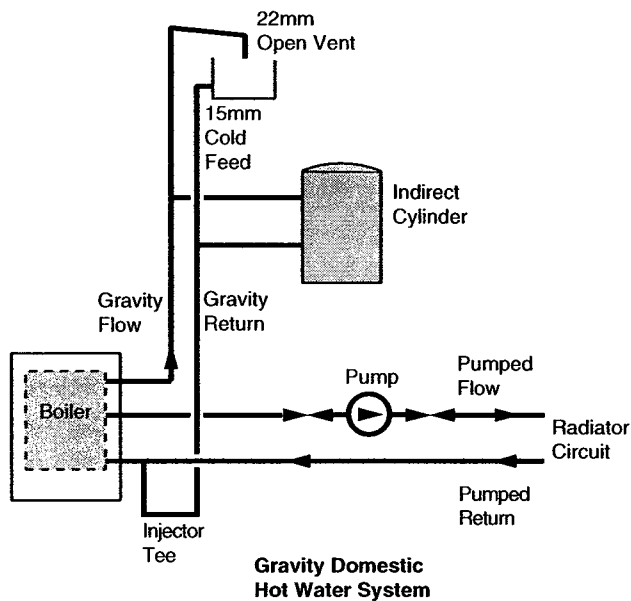

Fig. 4

1. The sizes of system pipes should be determined by normal methods.

2. The gravity flow pipe should rise vertically as close as possible to the boiler, avoiding sharp bends and tight elbows.

3. The open vent pipe should be a minimum of 22mm and must rise continuously to a point above the feed and expansion tank.

4. The flow pipe from the boiler may form part of the vent pipe.

5. No part of the open vent should contain a valve.

6. The brass injector tee must be fitted to the boiler return on all systems incorporating a gravity circuit.

7. The circulating head should not be less than 1m (3ft) with a maximum horizontal run of 3m (10ft) when using 28mm pipes. Smaller pipe sizes and longer horizontal runs are acceptable with suitably increased circulating heads.

8. The gravity circuit should be designed with a minimum of restriction, avoiding possible air traps and long horizontal runs.

9. The system should be designed to prevent gravity circulation in the heating system when the pump is not running.

### 3.8 Sealed Systems

1. **Installation.** The installation must comply with the requirements of BS 6798:1987 and BS 5449:1. The British Gas publication "British Gas Specification for Domestic Wet Central Heating Systems" should also be consulted.

2. **Pressure Relief Valve.** A non-adjustable spring loaded pressure relief valve, preset to operate at 3 bar (45 lbf/in<sup>2</sup>) shall be used. It must comply with BS 6759:1 and include a manual testing device. It shall be positioned in the flow pipe either horizontally or vertically upwards and close to the boiler. No shut off valves are to be placed between the boiler and the safety valve. The valve should be installed with a discharge pipe which permits the safe discharge of steam and hot water such that no hazard to persons or damage to electrical components is caused.

3. **Pressure Gauge.** A pressure gauge incorporating a fill pressure indicator, covering the range 0-4 bar (60 lbf/in<sup>2</sup>) shall be fitted to the system. It should be connected to the system, preferably at the same point as the expansion vessel. Its location should be visible from the filling point.

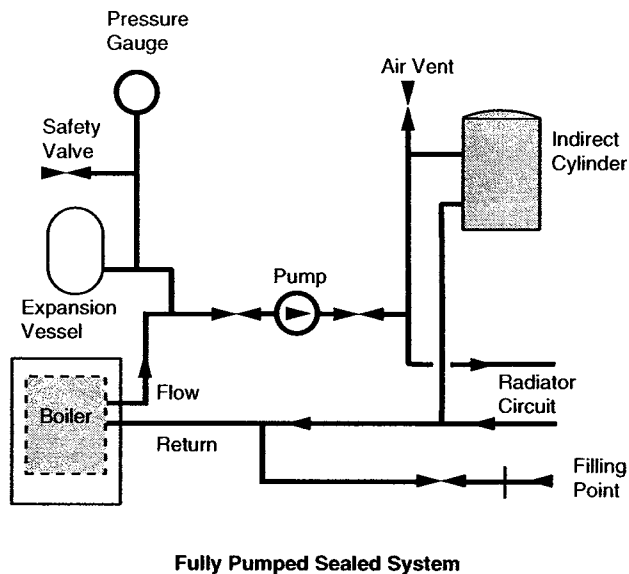
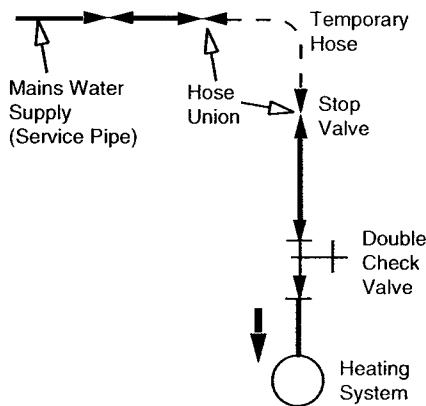

Fig. 4a

## 3.0 System Details

### 3.8 Sealed Systems (cont)



Filling a Sealed Water System (Method 1)

#### Mains Topping Up Method

**NOTE:** This method of filling a sealed system may only be used if acceptable to Local Water Undertaking

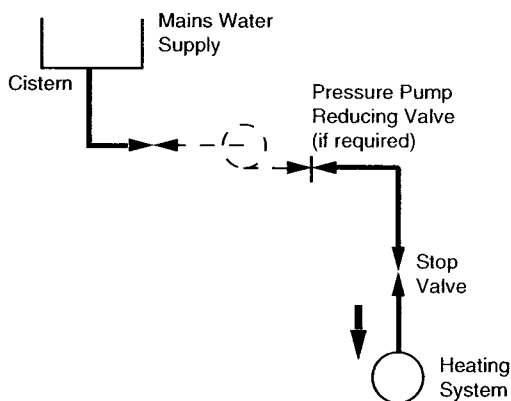

Filling a Sealed Water System (Method 2)

#### Cistern Filling Method

**NOTE:** Cistern to be supplied through a temporary connection from a service pipe or cold water distributing pipe

Vessel Charge Pressure (bar)	0.5	1.5
Initial System Pressure (bar)	1.0	1.0
Expansion Vessel Volume (litres)	$V \times 0.11$	$V \times 0.087$

Table 1

**4. Expansion Vessel.** A diaphragm type expansion vessel to BS 4814:1 shall be fitted close to the inlet side of the pump. The connecting pipework should not be less than 15mm. Pipework connecting the expansion vessel should not incorporate valves of any sort.

Methods of supporting the vessel are supplied by the vessel manufacturer.

The nitrogen or air charge pressure of the expansion vessel shall not be less than the hydrostatic head, (height of the top point of the system above the expansion vessel). To size the expansion vessel it is first necessary to calculate the volume of water in the system in litres. The following volumes may be used as a conservative guide to calculating the system volume.

Boiler Heat Exchanger:	1.6 litres
Small Bore Pipework:	1 litre per kW of system output
Micro Bore Pipework:	7 litre
Steel Panel Radiators:	8 litre per kW of system output
Low Water Capacity Radiators:	1 litre per kW of system output
Hot Water Cylinder:	1 litre per kW of system output

If the system is extended, the expansion vessel volume may have to be increased unless provision has been made for extension. Where a vessel of the calculated size is not available, the next available larger size should be used.

The boiler flow temperature is controlled at approx 82°C.

The vessel size can now be determined from the information in table 1 where V = System volume in litres.

**5. Cylinder.** The hot water cylinder must be an indirect coiler type.

**6. Method of Make Up.** Provision shall be made for replacing water loss from the system either:-

- From a make up vessel or tank mounted in a position higher than the top point of the system and connected through a non-return valve to the system on the return side of the hot water cylinder or the return side of all heat emitters.
- Where access to a make up vessel would be difficult by using the mains top up method or a remote automatic pressurisation and make up unit.

**7. Mains Connection.** There shall be no connection to the mains water supply or to the water storage tank which supplies domestic hot water even though a non-return valve, without the approval of the Local Water Authority.

**8. Filling Point.** A filling point connection on the central heating return pipework must be provided to facilitate initial filling and pressurising and also any subsequent water loss replacement/refilling.

The sealed primary circuits may be filled or replenished by means of a temporary connection between the circuit and a supply pipe, provided a 'Listed' double check valve or some other no less effective backflow prevention device is permanently connected at the inlet to the circuit and the temporary connection is removed after use.

The filling method adopted must be in accordance with all relevant water supply regulations and use approved equipment.

Your attention is drawn to: for GB: Guidance G24.2 and recommendation R24.2 of the Water Regulations Guide, for IE: the current edition of IS 813 "Domestic Gas Installations".

## 4.0 Site Requirements

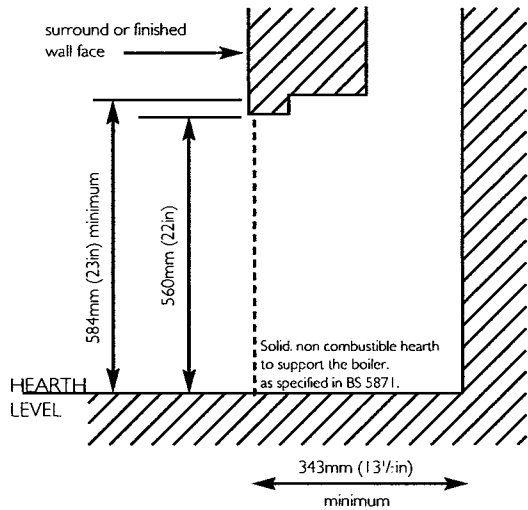

When correctly installed the centre line of the boiler flue socket will be 258mm-305mm (10 1/8 in-12 in) from the surround or finished wall face.

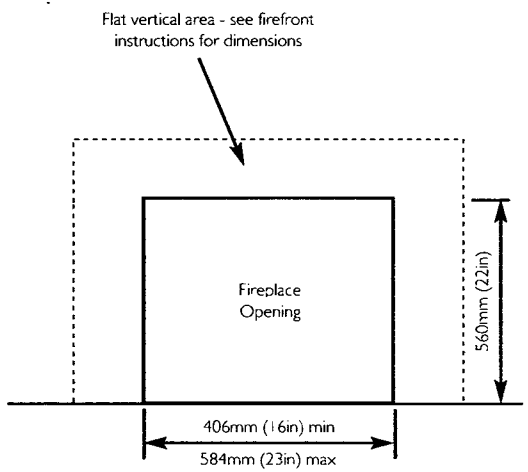

NOTE: For VP3 & SP3 maximum fireplace opening is 508mm (20 in)

Fig. 5

### 4.1 Builders Opening (Fig. 5)

1. The boiler unit is designed to fit within a standard builders opening, the minimum dimensions of which are as shown.

Height	584mm (23in)
Width	584mm (23in)
Depth	343mm (13 1/2in)

2. The opening should be soundly constructed of brick, pre-cast concrete or be a proprietary builders opening.

3. **The base of the opening should be sound and non-combustible and must be flat and level.**

4. The base of the builders opening should be at the same height as the finished level of the hearth or be the required height of 100-125mm (4-5 in) above floor level for a wall mounted firefront installation.

**IMPORTANT:** If a false chimney breast is intended to house the boiler, a simulated builders opening, within the breast, must be provided.

5. The builders opening must not communicate with voids, pipe ducts or spaces other than the room in which the appliance is situated.

### 4.2 Location

1. The appliance must be installed in the living space of a dwelling.

2. Restrictions to the siting of the appliance are covered by BS 5546. The appliance may not be installed in bathrooms, shower rooms, bedrooms or bed sitting rooms.

### 4.3 Fireplace Opening & Surround

1. If a fireplace surround is to be used, it must be centrally placed and have opening sizes and a vertical flat area as detailed in the Installation and Servicing Instructions for the fire.

2. **No Surround:** The appliance can be fitted without a surround. The fireplace opening and vertical flat areas as per above still apply. Maximum fireplace opening sizes are preferable for ease of installation and service.

3. **Hearth Mounting:** All Bermuda Firefronts are suitable for hearth mounting. The hearth must be on the same level as the builders opening. The hearth must be non-combustible and comply with BS 5871: Pt 1.

4. **Wall Mounting:** A number of Bermuda Firefronts are aesthetically suitable for wall mounting above the level of the room floor in instances where there is no hearth.

The base of the builders opening on which the boiler rests should be 100-125mm (4-5 in) above floor level.

The following firefronts are suitable for wall mounting:

Bermuda SP3	Bermuda PWS Deluxe
Bermuda C5	Bermuda RG3
Bermuda C5W	Bermuda LFE5 Super

## 4.0 Site Requirements

### 4.5 Flue

1. The following guidelines indicate the general requirements for installation of flues. For GB recommendations are given in BS 5440 Part 1. For IE recommendations are given in the current edition of I.S. 813 "Domestic Gas Installations".

The flue must have a minimum vertical height of 3m (10ft) and have a minimum internal cross section area of 12,700 mm<sup>2</sup> (20in<sup>2</sup>), this is satisfied by a flue of 125mm (5in) internal diameter.

**A suitable terminal is required for all installations.**

#### 2. 9in X 9in Brick

Flues previously used for other fuels must be thoroughly swept. The flue must be lined with a 125mm (5in) flexible liner. The bottom of the liner should terminate 500mm (20in) above the base of the builders opening. The flue must be sealed between the liner and the brickwork at both the top and bottom.

#### 3. Acid Resistant Liner

A flue constructed of acid resistant liners is satisfactory provided the size requirements are met. The boiler flue outlet can be connected to the flue by means of a short length of 125mm (5in) of flue pipe. A seal must be made in the annular space between the outer face of this flue pipe and the acid resistant liner.

#### 4. Precast Flues

These must conform to BS 5440 Pt 1 and be correctly installed without intrusion of cement into the flue passage.

#### 5. Proprietary Flues

A flue of this type must meet the size requirements specified and be installed in accordance with the flue manufacturers recommendation and relevant codes of practice.

**An approved terminal must be installed.**

## 4.0 Site Requirements

### 4.6 Ventilation

1. Ventilation air supply should be in accordance with the relevant standards. In GB this is BS 5440 Pt. 2. In IE this is I.S. 813 "Domestic Gas Installations". The permanent ventilation area size requirements are given in the firefront Installation and Servicing Instructions.

2. The permanent vent may be directly into the room containing the appliance. The vent may also be sited in another (not a bedroom, toilet, bathroom or kitchen) room provided an interconnecting vent is used.

3. The vent must not be installed inside the builders opening. The vent should be sited following good practise for a habitable room. We recommend the use of the Stadium "Black Hole" ventilator which is available from your local merchant.

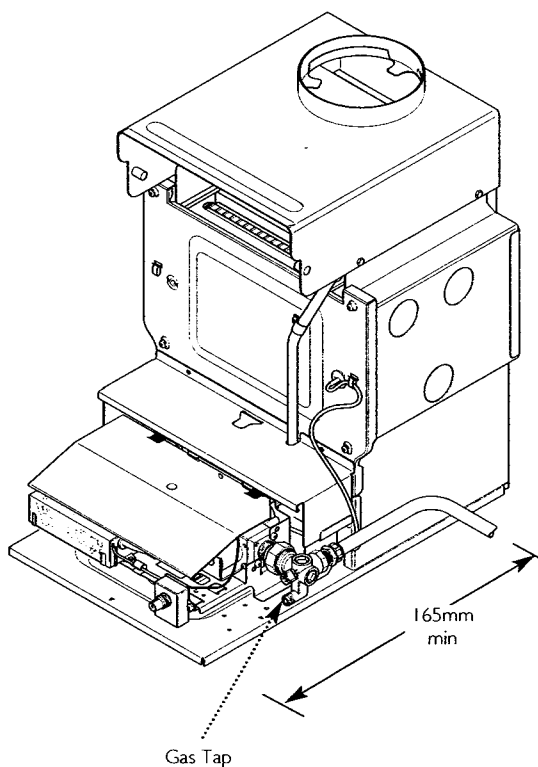

Fig. 6

### 4.7 Gas Supply (Fig. 6)

1. The gas installation should be in accordance with relevant standards. In GB this is BS 6891. In IE this is I.S. 813 "Domestic Gas Installations". The connection at the appliance is Rc 1/2 (1/2in BSPT internal) located at the rear of the gas tap.

2. Ensure the pipework from the meter to the appliance is of adequate size. It is necessary to route the gas supply pipe to the right hand side of the builders opening. It must be routed so as not to restrict the installation and servicing of the appliance.

### 4.8 Electrical Supply

1. External wiring must be correctly earthed, polarised and in accordance with relevant regulations/rules. In GB this is the current I.E.E. Wiring Regulations. In IE reference should be made to the current edition of the ETCI rules. The mains supply is 230V ~ 50Hz fused at 5A. **A permanent live electrical supply is required for all firefronts with lighting effects i.e. VP3, SP3, RG3, SL3, LFE5 Super and GF3 Super. The permanent live is also required to operate the electronic ignition on VP3, SP3 and RG3 models.**

**NOTE:** The method of connection to the electrical supply must facilitate complete electrical isolation of the appliance. Connection may be made via a fused double pole isolator with a contact separation of at least 3mm on all poles and serve the appliance and system controls only.

2. The cable within the builders opening should be 0.75mm<sup>2</sup> to IEC 53 code 227 (heat resistant).

3. It is preferable to route the electrical supply cable to the left hand side of the builders opening. If however it must come from the right hand side it must be routed via the clips provided and not restrict the servicing of the appliance.

4. The cable must be routed to avoid contact with the metal combustion box and hood.

## 5.0 Electrical

### 5.1 Illustrated Wiring Diagram

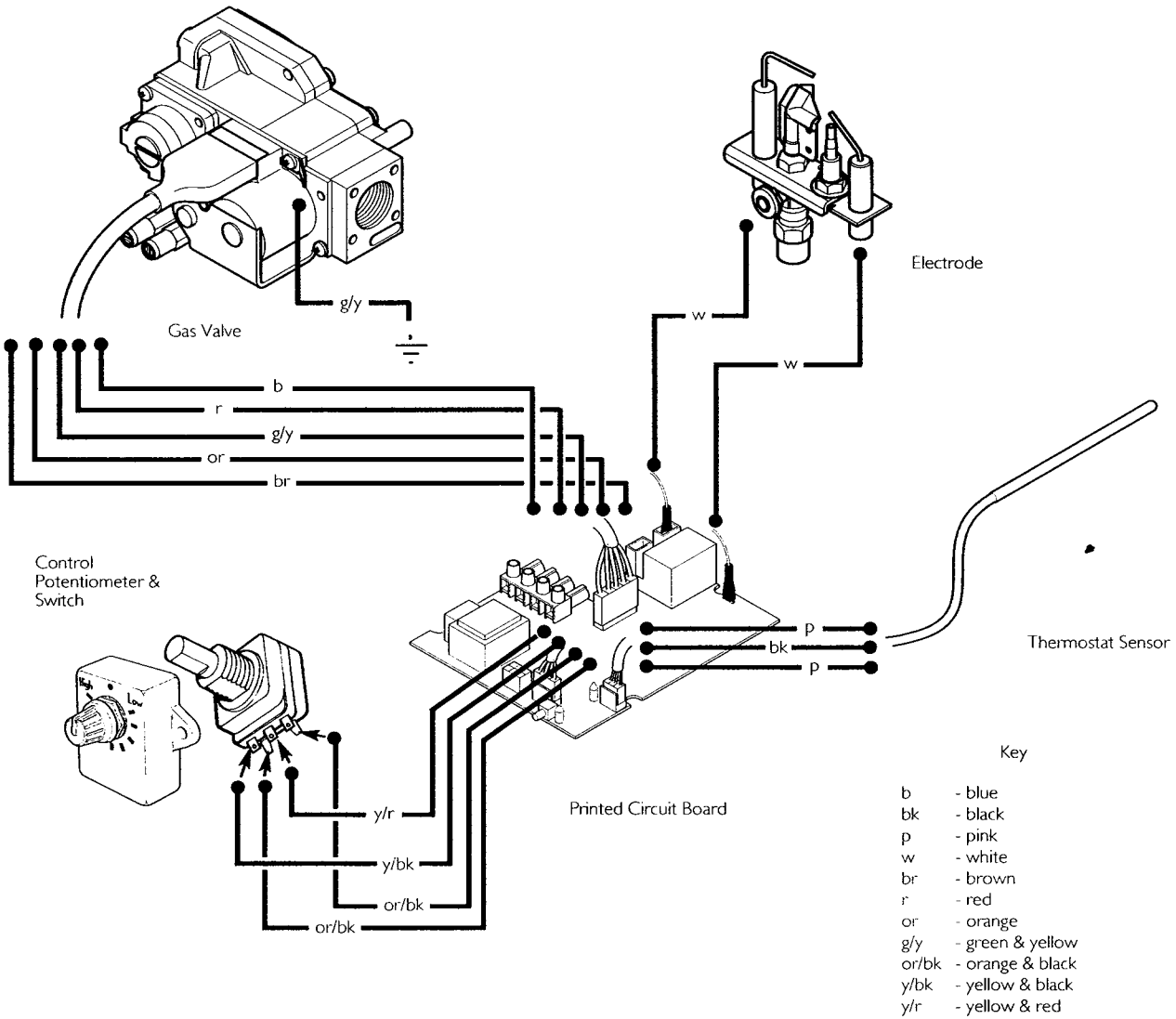

### 5.2 Functional Flow Diagram

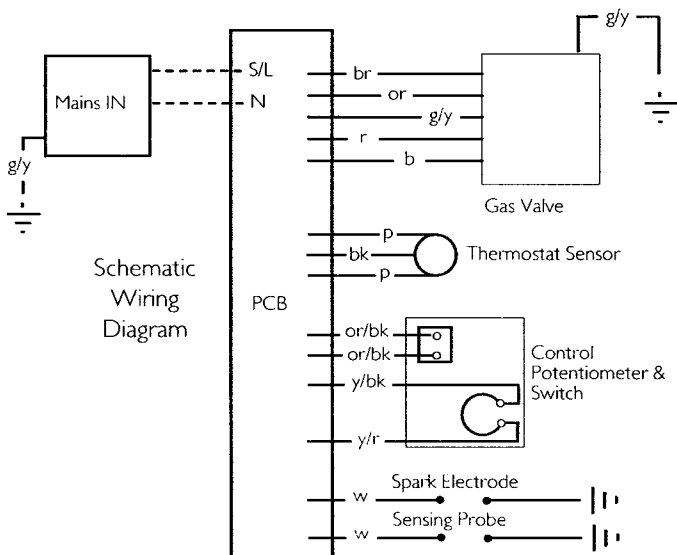

## 6.0 Installation

### 6.1 Initial Preparation

1. Remove the outer carton from the boiler pack. Discard the packing pieces. Remove the boiler hood and fitting kit.
2. The boiler as supplied has the flow and return water connections at the left hand side of the appliance. If this is the required orientation, go to section 6.3.

### 6.2 For installations requiring the water connections at the right hand side proceed as follows (Fig. 7 & 8):

1. Leave the boiler on its back on the carton base.
2. Remove the thermostat lead from its clip. Withdraw the thermostat sensor from the pocket.
3. Unfasten the four screws retaining the boiler door and remove. Remove the rubber seal and thermostat protection cover.
4. Lift out the 3 heat exchanger baffles, noting their orientation (they are marked 'TOP' and 'FRONT').
5. Lift the heat exchanger from the appliance and remove the side blanking plate.
6. Transfer the 3 sealing rings from the holes in the left hand side of the boiler to those on the right.
7. Rotate the heat exchanger to place the water connections at the right hand side, return the heat exchanger to the combustion box.

#### DO NOT TURN THE HEAT EXCHANGER UPSIDE DOWN

**NOTE:** The heat exchanger is correctly oriented when the three water connections line up with the holes in the right hand side of the combustion box and the thermostat pocket aligns with the corresponding hole in the door. The unfinned heat exchanger water tubes face the burner.

8. Remove the blanking disc from the left hand hole in the boiler door and replace with the rubber seal. Fit the blanking disc into the right hand hole.
9. Replace the heat exchanger baffles and blanking plate. Refit boiler door. Refit the thermostat sensor into the pocket. Route the thermostat lead into the clip.

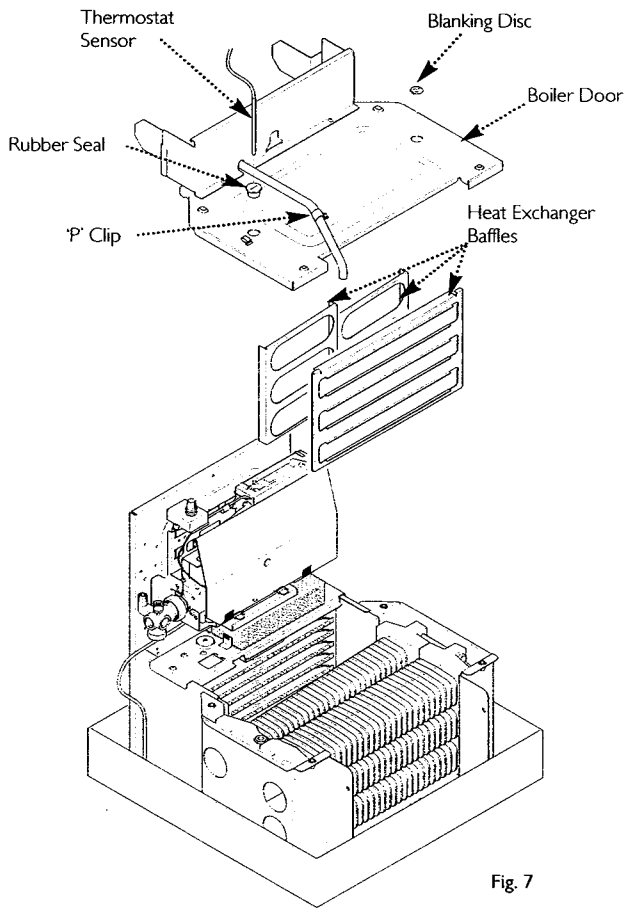

Fig. 7

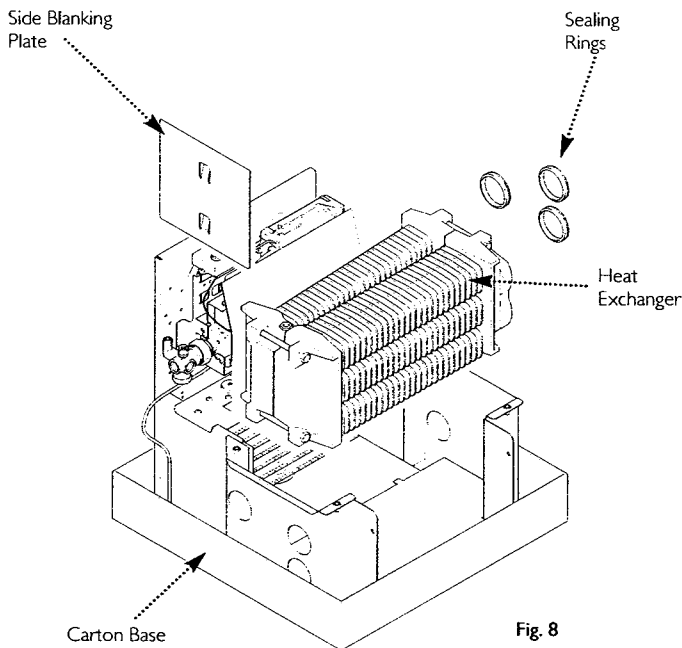

Fig. 8



## 6.0 Installation

### 6.3 Fitting the Boiler Hood

1. Stand the boiler upright on the carton base.
2. The hood may be fitted now or when the boiler is in situ. Secure using the four nuts and set screws provided (Fig. 12).

### 6.4 Siting the Boiler

1. The fireplace and builders opening should be as described under '4.0 Site Requirements' and be clean, sound and level.
2. The flue should be installed as described under '4.0 Site Requirements'.
3. It may be desirable to insert the required fittings into the heat exchanger at this point, depending on the size of the fireplace opening and whether or not the gravity injector tee is to be used.
4. Locate and mark the centre line of the finished opening and hearth (Fig. 15).
5. Hold the boiler by its combustion box at either side of the heat exchanger, lift from the packing base and place into the opening.
6. Align the boiler centrally using the "V" mark on the front centre of the appliance base. Check the distance between each side of the base and opening. They should be equal (Fig. 15).
7. The appliance positioning into the opening is variable to cater for pipe/flue alignment. The boiler may be positioned by locating the front face of the fireplace anywhere between the two "V" marks on either side of the appliance base.
8. Mark the hearth through the two slots in the base (Fig. 14).

### 6.5 Securing the Boiler

1. It is important that the boiler is secured to the base of the builders opening.
2. The hearth should be drilled as follows: Remove the boiler and drill the hearth. Insert suitable plugs. Replace the boiler & check the alignment within the opening is correct. Secure the boiler with two screws.

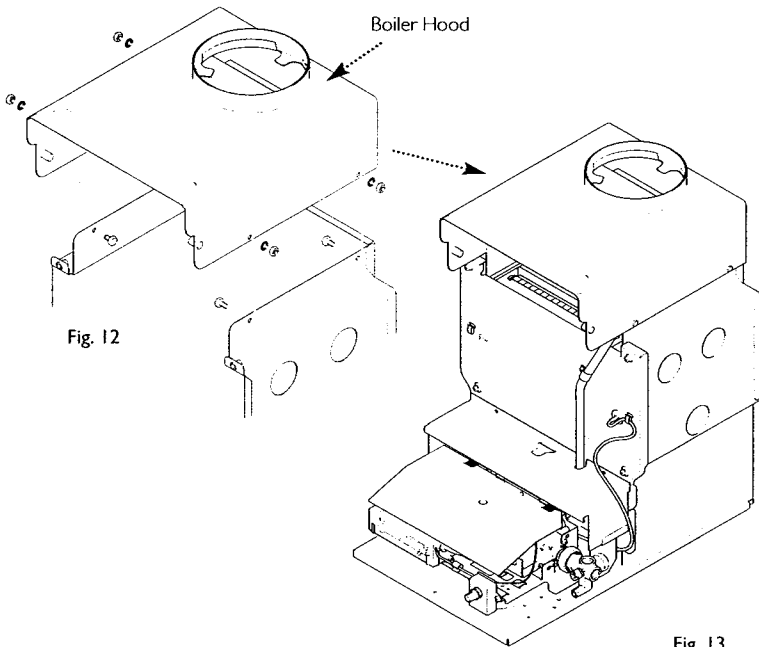

Fig. 12

Fig. 13

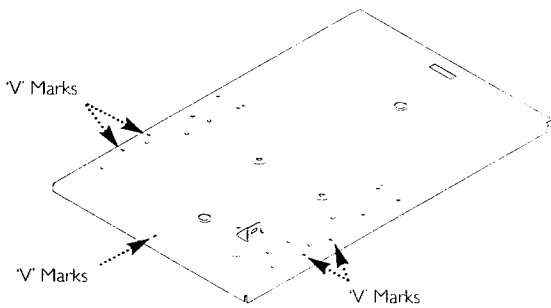

Fig. 14

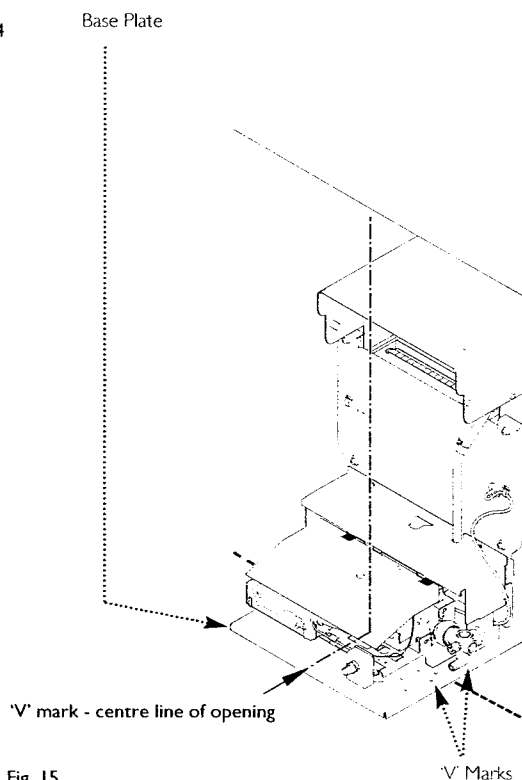

Fig. 15

## 6.0 Installation

### 6.6 Water Connections

1. The boiler has one return and two flow tappings, Rc1 (1 in BSP). The flows are the two upper tappings. The return is the lower position tapping and is marked RETURN. It is essential the flow and return pipes are connected to the correct tappings.

### 6.7 Fully Pumped Systems (Fig. 16)

1. A 1 in x 22mm threaded adaptor, compression nut and olive are provided in the kit for the return connection.
2. The 1 in x 22mm threaded adaptor provided must be fitted to the lower tapping marked RETURN. Connect the pumped return into the adaptor using the nut and olive.
3. Fit a 1 in x 22mm threaded adaptor into one of the higher tapping positions marked FLOW and connect the pumped flow into the adaptor.
4. Fit a 1 in plug to the remaining connection.
5. Follow the instructions under 'System Details'.

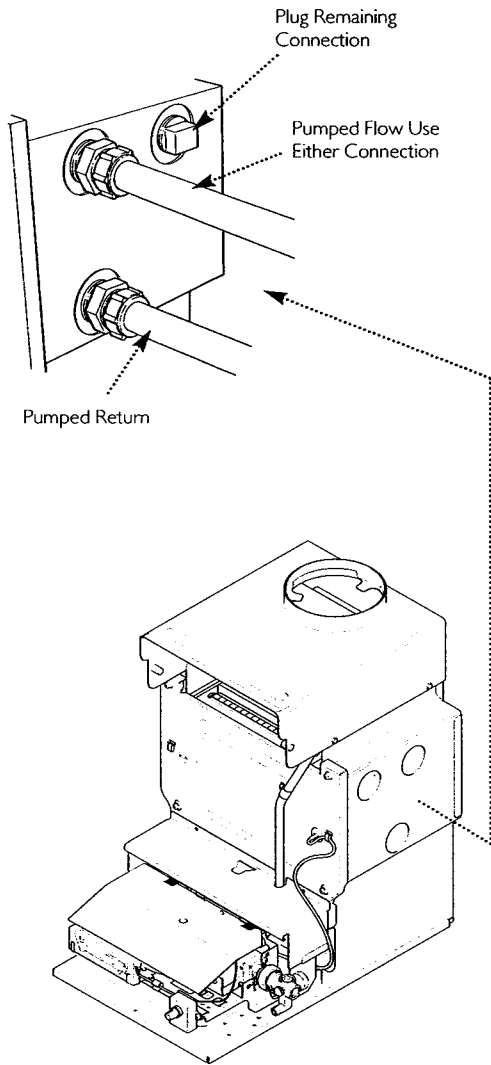

Fig. 16

## 6.0 Installation

### 6.8 Pumped Heating & Gravity Hot Water (Fig. 17)

1. A 1 in x 22mm threaded adaptor, two compression nuts and olives and a brass injector tee piece are provided in the kit for the return connection.

**NOTE:** The injector tee must be fitted to the return of all systems with gravity domestic hot water.

2. The 1 in x 22mm threaded adaptor provided must be fitted to the lower tapping marked RETURN.

3. Fit the injector tee into the adaptor. The injector tee may be oriented as shown to facilitate connection to the gravity return pipework.

4. Connect the pumped return to the 22mm compression fitting of the injector tee.

5. Take the gravity hot water return pipe to a level beneath that of the injector tee and connect upwards to the 28mm branch of the injector tee, oriented as shown.

6. Connect the pumped flow to one of the connections marked FLOW. Connect the gravity flow to the remaining connection.

7. The gravity flow pipes must rise vertically as close as possible to the appliance. Ensure the pipework is routed such that it does not introduce an airlock in the boiler.

8. Follow the instructions under system details as regards the vent pipe and cold feed.

### 6.9 Gas Connection (Fig. 19)

1. Connection to the gas supply is Rc 1/2 (1/2 in BSPT) internal located at the rear of the gas tap. The gas supply pipe must be routed from the right hand side.

2. The positioning of the gas supply pipe must not restrict the servicing of the appliance or installation of the fire.

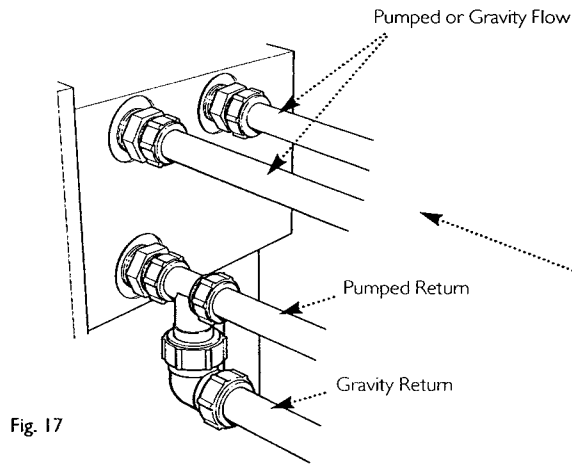

Fig. 17

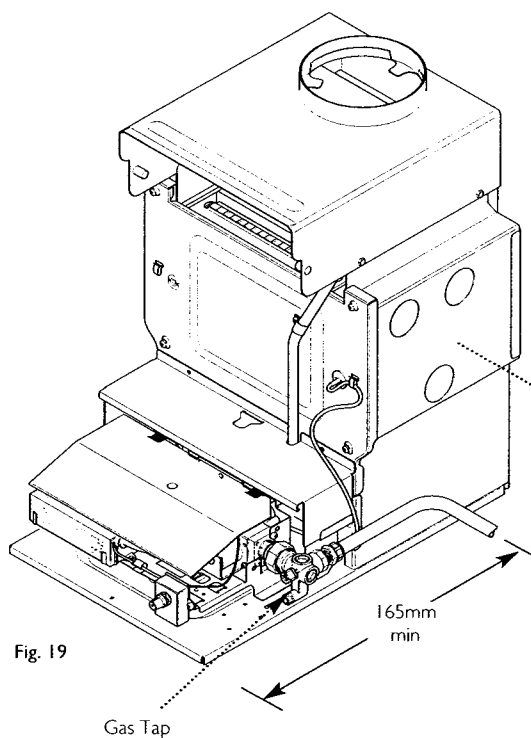

Fig. 19

## 6.0 Installation

### 6.10 Electrical Connection

1. The appliance requires an electrical supply from the heating controls system. **A permanent live supply is required for firefronts which have electronic ignition and/or light effects..**

**WARNING:** The appliance must be earthed. The input cable for the appliance should be 0.75mm<sup>2</sup> to IEC Code 227 (heat resistant). The system external controls and the appliance must be supplied by the same isolator.

### 6.11 Making the Electrical Connection

1. Take the 3 pin plug and lead assembly from the gas fire contents kit and remove the 4 pin electrical plug from the control PCB. Remove the cover from the 4 pin plug and undo the cable clamps (Fig. 22).

2. The boiler plug is supplied as shown; An earth lead connects to the boiler chassis (Fig. 24).

3. If the firefront being installed is equipped with either lighting effects or lighting effects and electronic ignition the plug must be wired as Fig. 25.

Connect the control switched live to SL.

Connect neutral to N and earth to  $\frac{1}{\text{---}}$ .

Connect the permanent live to L.

The fire earth must connect to the chassis.

Neutral and live of the fire supply cable can then be connected to N and L respectively.

5. If the firefront does not require a permanent live feed, wire the plug as shown in Fig. 23. The loose terminal block can be discarded.

5. Re-fit the cable clamps ensuring that the outer insulation is securely held and re-fit the plug cover. **Ensure that all cables are routed away from the boiler casing and hood.**

### 6.12 Flue Connection (Fig. 26)

1. If not already done so, fit the boiler hood now. Locate the flue within the flue socket and secure with the three self tapping screws provided in the kit. Seal the flue against the flue outlet socket.

### 6.13 Completion

1. Seal off any secondary openings within the builders opening after wrapping the gas and water pipes through the brickwork and within the opening itself. (B.S. 5871 Part 1).

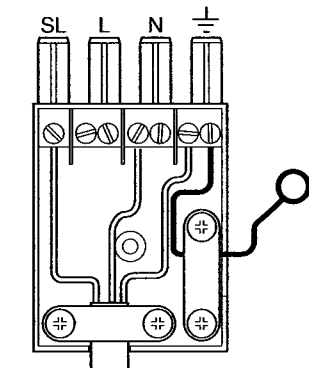
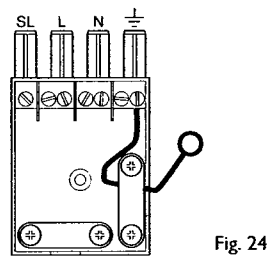
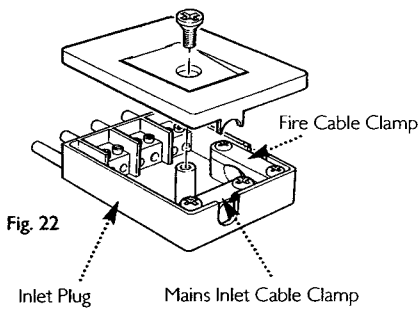
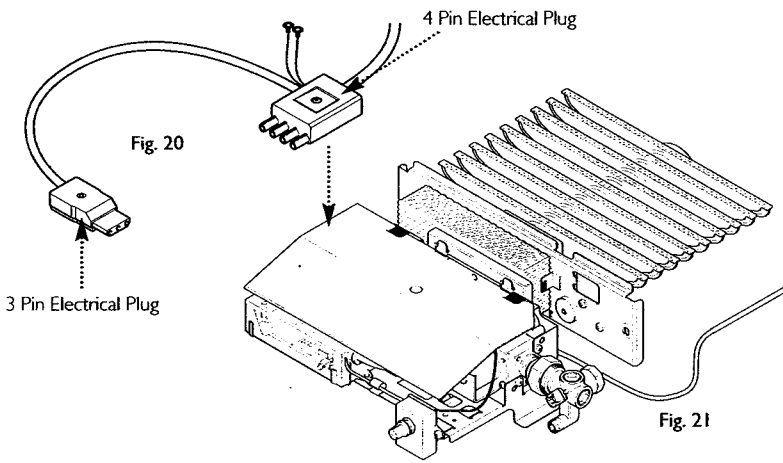
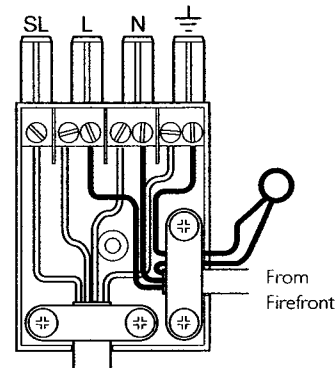

Fig. 23



From Control System & Permanent Live

Fig. 25

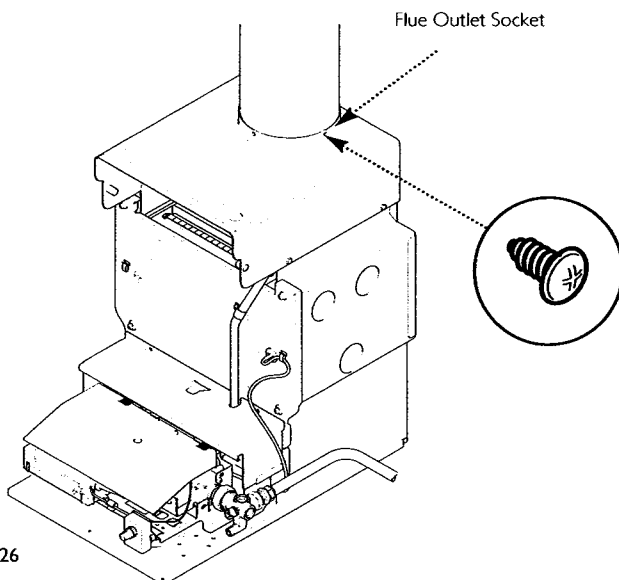

Fig. 26

## 7.0 Commissioning the Appliance

### 7.1 Commissioning the Appliance

1. The system must be flushed in accordance with BS 7593 (See Treatment of Water Circulating Systems section 3.2) and the flushing agent manufacturers instructions, further guidance can be obtained from BS 5449 Section 5.

2. Turn the gas service tap  $\frac{1}{4}$  turn from the OFF position (Fig. 28). This will supply gas to the boiler only. Purge according to in GB BS 6891 and in IE the current edition of IS. 813 "Domestic Gas Installations".

3. Turn the boiler thermostat to the OFF position (Fig. 27).

4. Ensure that all external controls e.g. room stat, timer etc are calling for heat and turn on the mains electrical supply.

5. Slacken the pressure test point sealing screw and connect a pressure gauge (Fig. 27).

The pilot is intermittent and lights when the boiler thermostat is calling for heat.

To operate the pilot turn the boiler thermostat to HIGH. The burner will also light shortly after the pilot has been established.

The boiler is fitted with two diagnostic indicator lights that indicate the status of the boiler (Fig. 29). The high rate LED (yellow) can be seen through the top of the control box. The indicator LED can be seen through the front. Their sequence of operation is as follows:-

- a) No power-no lights.
- b) Switched live supplied indicator LED - orange.
- c) Pilot established indicator LED - green.
- d) Boiler fault - indicator LED red or flashing red.
- e) Boiler firing at maximum rate - high rate LED - yellow.
- f) Diagnostic indicator - high rate LED flashing yellow.

The pilot flame should be without a yellow tip and be approximately 20mm long. No adjustment is possible.

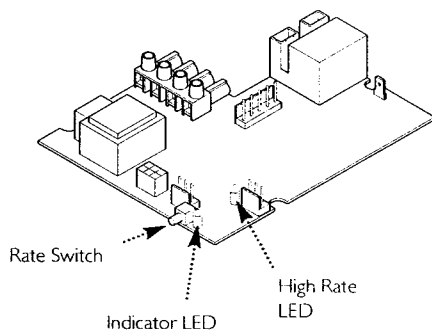
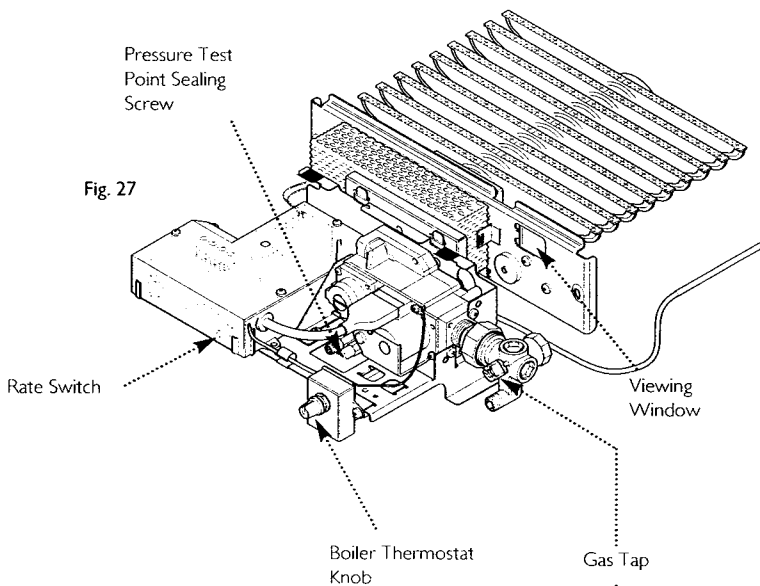
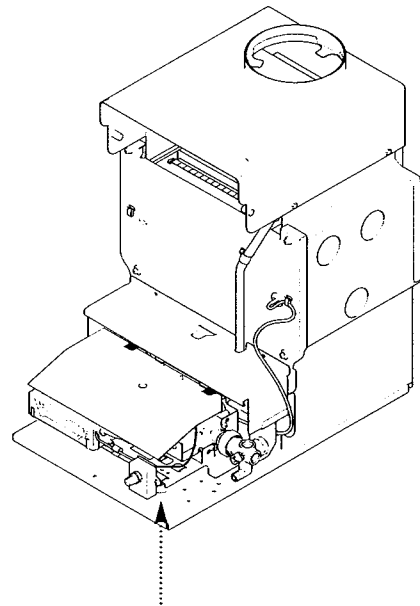

Fig. 29

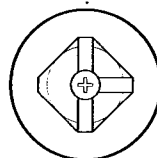

Fig. 28

## 7.0 Commissioning the Appliance

### 7.1 Commissioning the Appliance (Cont)

Operate the burner, this will run at low rate (This is factory set and no adjustment is necessary). Make further checks for leaks. Press and release the rate switch on the front of the control box. The high rate LED should illuminate yellow and the boiler fire at high rate (Fig. 31). **NOTE:** The boiler will only run at high rate if the boiler temperature is less than 70°C.

Check the burner setting pressure, adjusting if necessary, this has to be done while the LED is illuminated. This is done by removing the governor cover screw (Fig. 32) and adjusting the governor in either direction as required:- clockwise to increase, anticlockwise to decrease (Fig. 32).

Remove the pressure gauge and tighten the pressure test point sealing screw (Fig. 30).

The system must be flushed in accordance with BS 7593 (See Treatment of Water Circulating Systems section 3.2) and the flushing agent manufacturers instructions, further guidance can be obtained from BS 5449 Section 5. When all the air has been removed from the water circuit, the pump and radiators should be balanced to achieve the design temperature drop across the system.

Carefully read and complete all sections of the Benchmark Commissioning Checklist at the rear of this publication that are relevant to the appliance and installation. These details will be required in the event of any warranty work. The publication must be handed to the user for safe keeping and each subsequent regular service visit recorded.

For IE, it is necessary to complete a "Declaration of Conformity" to indicate compliance with I.S. 813. An example of this is given in I.S. 813 "Domestic Gas Installations". This is in addition to the Benchmark Commissioning Checklist.

### 7.2 Resetting the Boiler (Figs. 30 & 31)

1. If the indicator LED light is illuminated red/or flashing red, it is necessary to reset the appliance. To do this turn the boiler thermostat control knob fully anti-clockwise to the OFF position and wait until the light shows orange.

2. Turn the control knob clockwise to the required setting. The boiler will commence the ignition sequence.

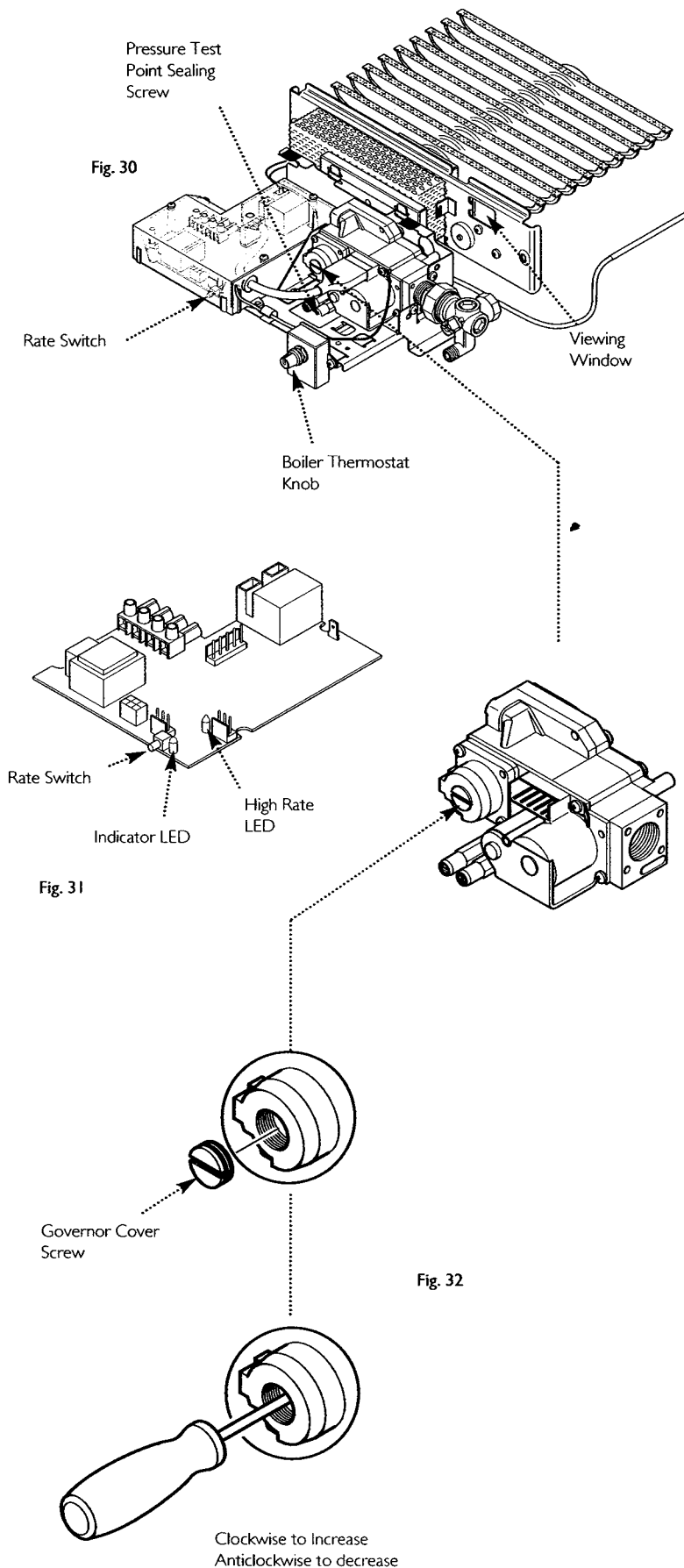

## 8.0 Annual Servicing

### 8.1 Annual Servicing

1. To perform annual servicing of the back boiler it is necessary to remove the firefront.
2. After servicing, complete the relevant Service Interval Record section of the Benchmark Commissioning Checklist at the rear of this publication.

### 8.2 Removal of Firefront

1. Isolate the electrical supply to the appliance.
2. Turn the boiler thermostat knob to the off position (Fig. 34).
3. Turn the gas service tap to the off position (Fig. 33).
4. Refer to the separate firefront instructions for the removal of the firefront.

### 8.3 Removal of Controls

1. Turn the boiler thermostat to "O" position (Fig. 34).
2. Pull the electrical input plug from the socket on the P.C.B. (Fig. 36).
3. Disconnect the union at the gas service tap and remove the fire feed pipe (Fig. 38).
4. Unclip the lead and remove the thermostat sensor from the boiler (Fig. 35).
5. Undo the four screws retaining the door and remove the door (Fig. 39).
6. Undo the two screws retaining the controls to the combustion box sides (Fig. 38).
7. Undo the screw holding the controls to the combustion box base tray (Fig. 38).
8. Withdraw the controls from the boiler.

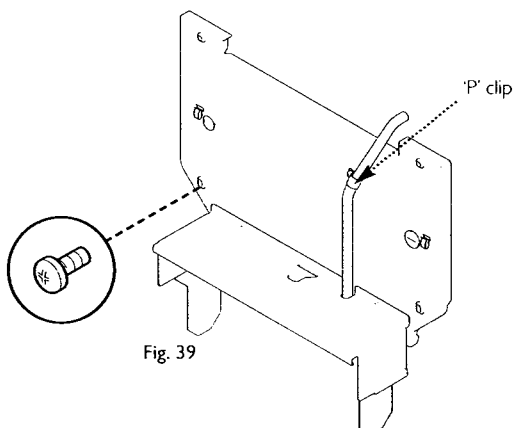
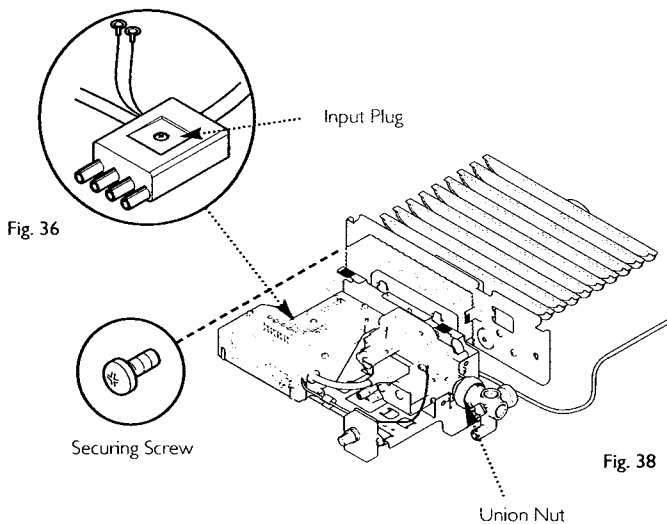
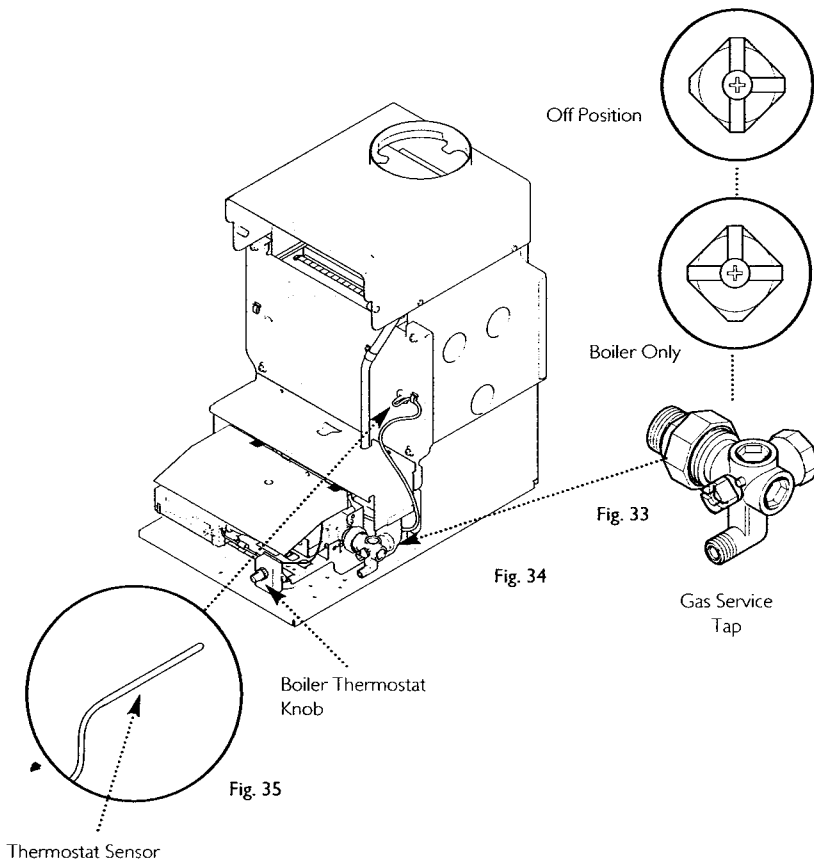

## 8.0 Annual Servicing

### 8.4 Cleaning the Lint Arrestor

1. Remove the lint arrestor from its retaining clips on the burner mounting plate and clean away any deposits (Fig. 40).

### 8.5 Cleaning the Burner & Main Injector

1. Remove the four hexagon headed screws holding the burner to the burner mounting plate (Fig. 41).

2. Carefully clean any deposits from the burner blades and venturi inlet (Fig. 41).

3. Remove the injector and copper sealing washer from the feed pipe. Clean the injector and reassemble in reverse order (Fig. 41).

4. Reassemble the burner in reverse order and refit the lint arrestor.

### 8.6 Cleaning the Pilot/A.S.D. Assembly

**NOTE:** No attempt should be made to clean the device using any hard tools, including pins or wire.

**WARNING:** The pilot/A.S.D. assembly must not be adjusted in any way.

1. The A.S.D. must not be altered so that it will not operate or be bypassed in any way.

2. Ensure that the pilot burner aeration hole is free from lint, debris etc (Fig. 44).

3. If necessary clean the electrode and target, and check that the spark gap is 2.5 - 4.0mm (Fig. 42).

4. The complete assembly must be replaced in the event of one or other component failure(s).

5. Only use a Genuine Baxi Spare Part.

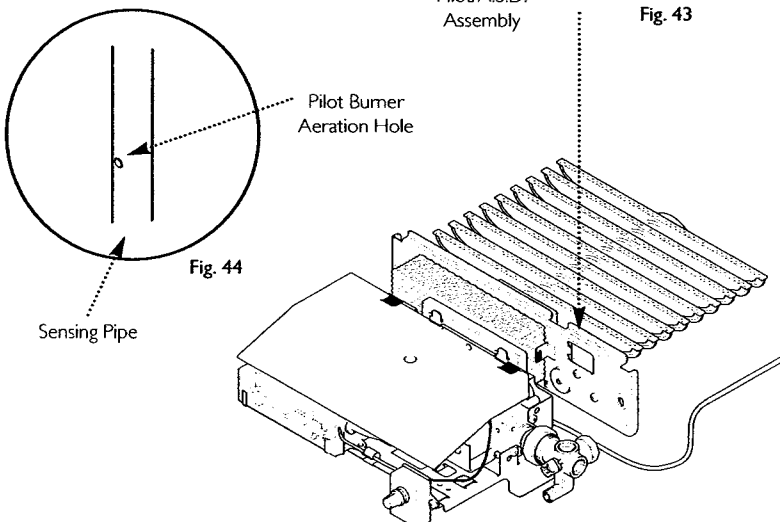
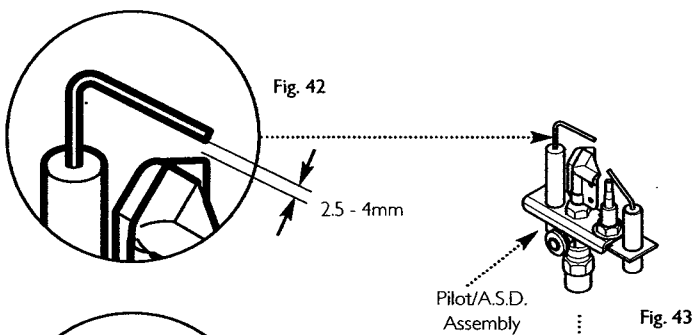
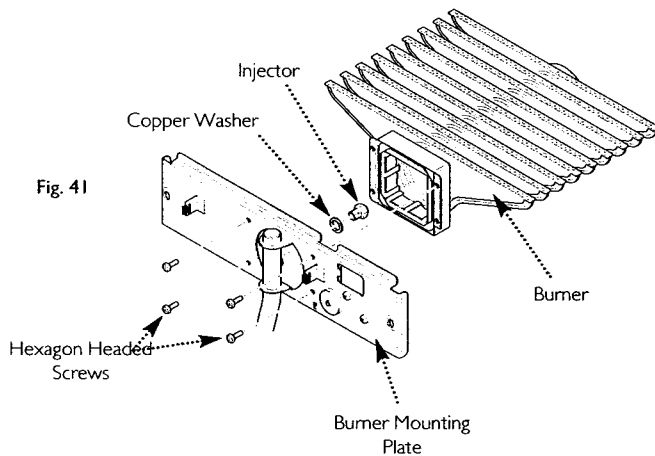
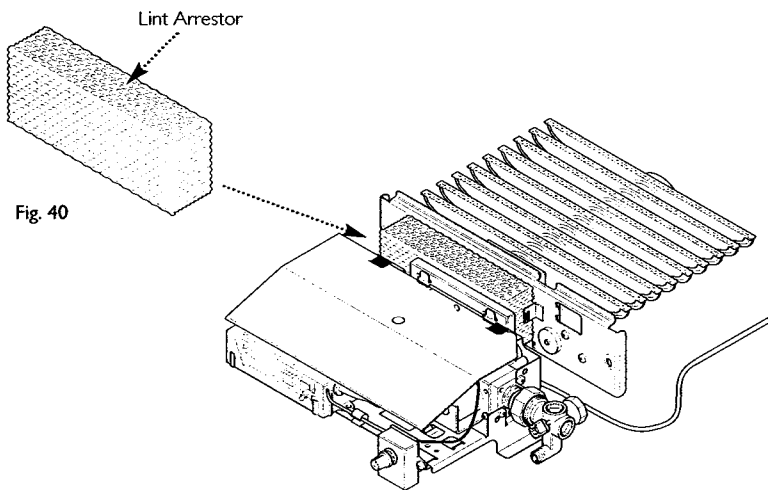



## 8.0 Annual Servicing

### 8.7 Cleaning the Heat Exchanger

1. Remove the top and the centre baffles from the heat exchanger, noting their orientation (Fig. 45).

2. Remove the side and rear insulation pieces by releasing the screws securing the burner heat shield assembly. Slide the burner heat shield assembly forward and lift front end to disengage from screws. Remove the heat shield (Fig. 47).

3. Remove the rear insulation first by sliding the bottom end forward (Fig. 47).

4. The side insulations can now be removed taking care not to catch the burner heat shield assembly securing screws (Fig. 47).

5. Clean between the heat exchanger fins and flueways with suitable brushes and remove any deposits from the combustion box base tray.

6. Clean away any lint or other deposits from the boiler hood and builders opening.

7. Reassemble the insulation in reverse order and refit the baffles.

8. Reassemble the appliance in reverse order, re-greasing the thermostat dial if required.

9. Re-commission the appliance and check for gas soundness.

10. Complete the relevant Service Interval Record section of the Benchmark Commissioning Checklist at the rear of this publication and then hand it back to the user.

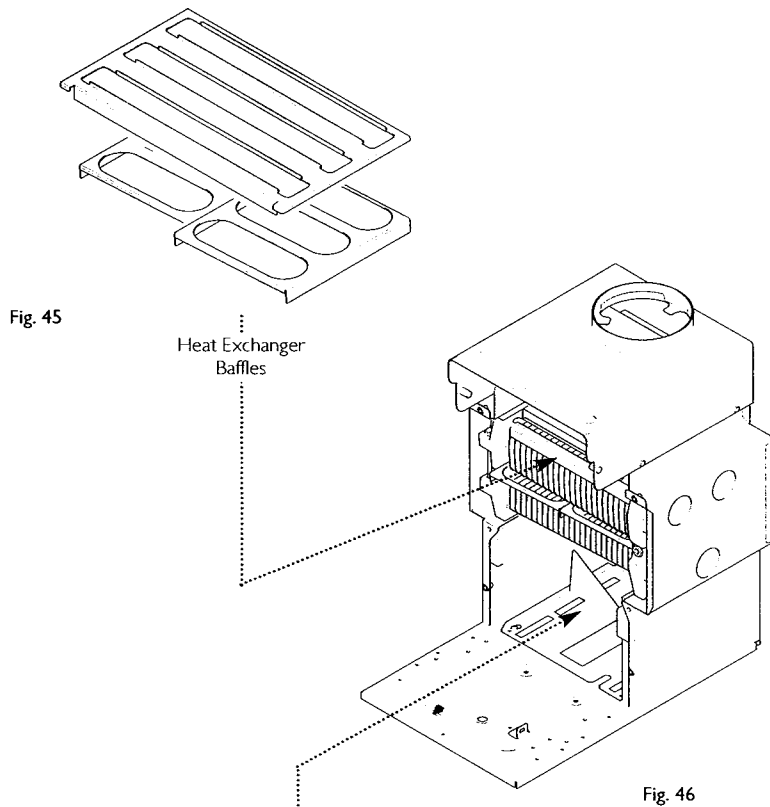

Fig. 45

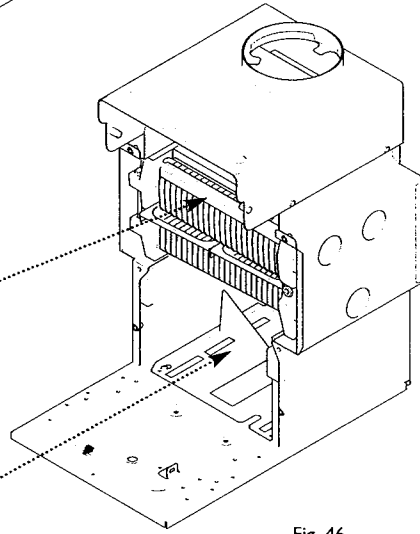

Fig. 46

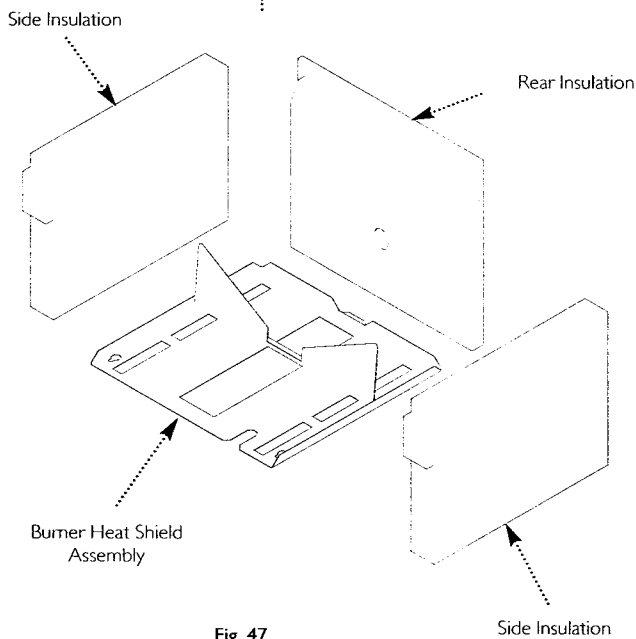

Fig. 47

## 9.0 Changing Components

### 9.1 Changing Components

1. To change any components on the back boiler it is necessary to remove the fire front.
2. After changing any components carry out gas soundness checks.

### 9.2 Removal of Firefront

1. Isolate the electrical supply to the appliance.
2. Turn the boiler thermostat knob to the off position (Fig. 51).
3. Turn the gas service tap to the off position (Fig. 50).
4. Refer to the separate firefront instructions for the removal of the firefront.

The following components can be changed with the controls in situ :- Lint Arrestor, Thermostat Sensor, Thermostat Potentiometer and P.C.B.

### 9.3 Lint Arrestor

1. Remove the lint arrestor by pulling forward away from its retaining clips (Fig. 51).
2. Reassemble in reverse order.

### 9.4 Thermostat Sensor (Fig. 51 & 52).

1. Remove the controls heat shield from its retaining clips.
2. Isolate the electrical supply to the appliance.
3. Unclip the lead and remove the thermostat sensor from the boiler.
3. Undo the three screws retaining the control box cover and remove the cover.
4. Disconnect the thermostat sensor plug from the PCB.
5. Reassemble in reverse order.

### 9.5 Thermostat Potentiometer (Fig. 53).

1. Remove the controls heat shield from its retaining clips.
2. Isolate the electrical supply to the appliance.
3. Undo the three screws retaining the control box cover and remove the cover.
4. Disconnect the thermostat potentiometer plug from the PCB and remove the potentiometer wires from their guide slot in the control box side.
5. Undo the screw holding the thermostat potentiometer to the controls mounting bracket and remove the potentiometer by disengaging its locating tab.
6. Reassemble in reverse order.

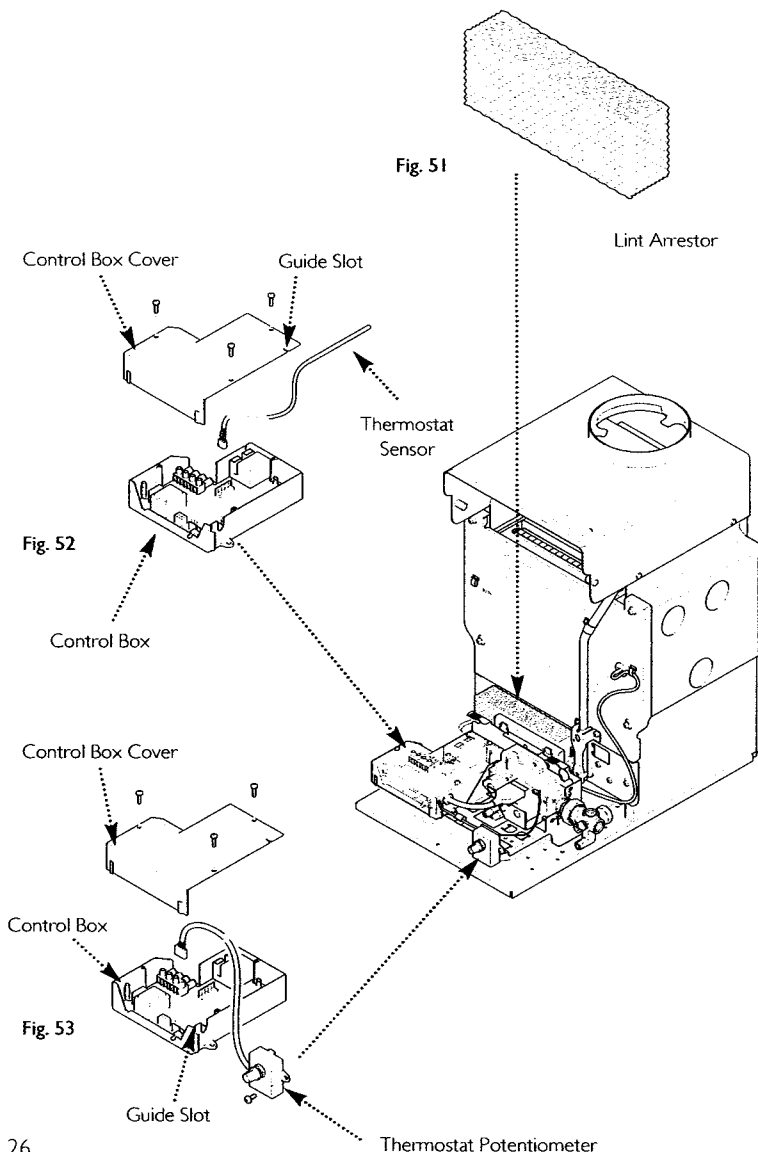
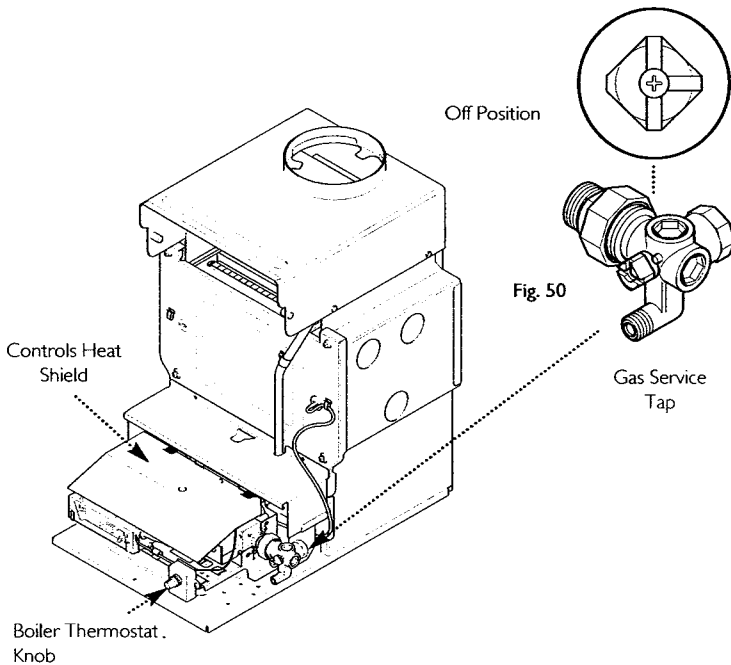

## 9.0 Changing Components

### 9.6 Printed Circuit Board (Fig. 54)

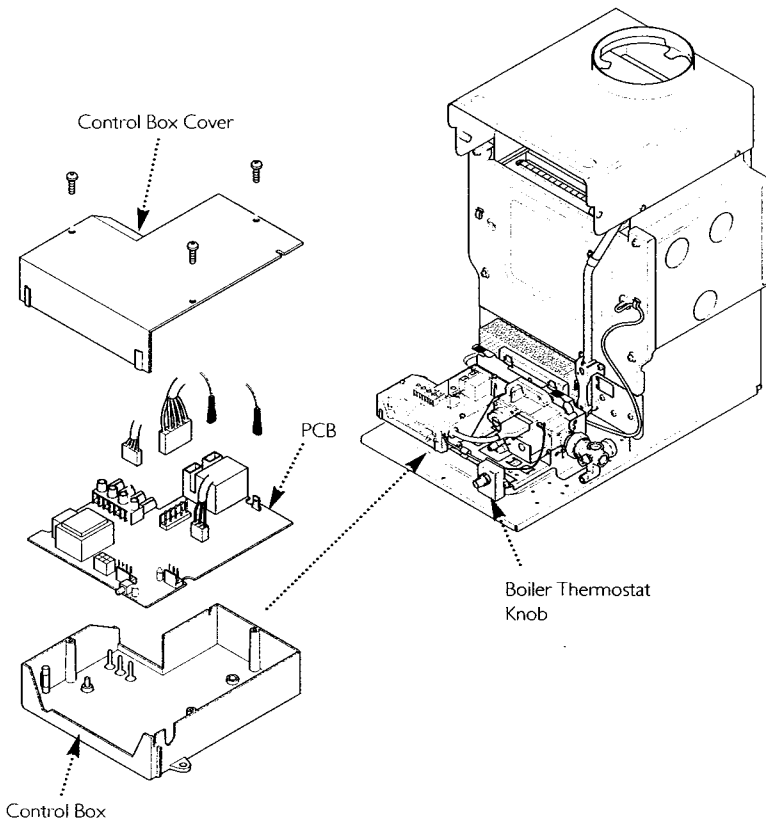

Fig. 54

1. Remove the controls heat shield from its retaining clips.
2. Isolate the electrical supply to the appliance.
3. Undo the three screws retaining the control box cover and remove the cover.
4. Disconnect the three multi-pin plugs, flame sensing lead and ignition lead from the PCB, noting their positions.
5. Pull the valve wiring grommet out of the slot in the control box.
6. Remove the PCB.
7. Fit the new PCB.

**NOTE:** A problem with the gas valve may cause the PCB to fail. Check the gas valve for continuity and short circuit.

8. Reassemble in reverse order.

To change the Gas Valve, Burner and Main Injector, Electrode/Leads, and Pilot/A.S.D. Assembly proceed as follows:-

### 9.7 Removal of Controls

1. Turn the boiler thermostat to "O".
2. Pull the input plug from the socket on the PCB (Fig. 56).
3. Disconnect the union at the gas service tap and remove the fire feed pipe (Fig. 57).
4. Unclip the lead and remove the thermostat sensor from the boiler.
5. Undo the four screws retaining the door and remove the door (Fig. 58).
6. Undo the two screws retaining the controls to the combustion box (Fig. 57).
7. Undo the screw holding the controls to the combustion box base tray (Fig. 57).
8. Withdraw the controls from the boiler.

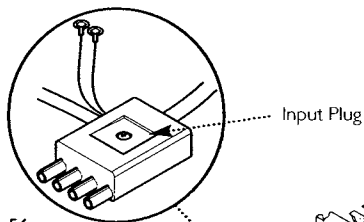

Fig. 56

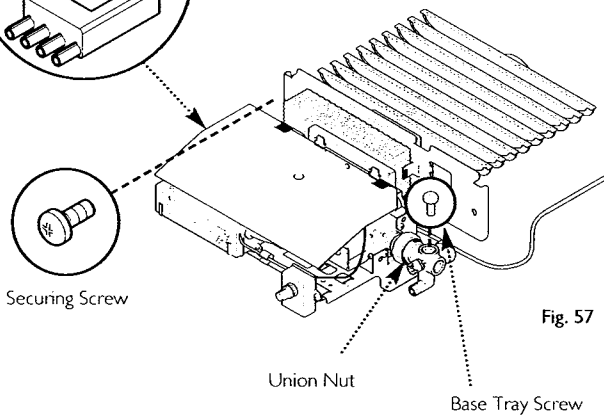

Fig. 57

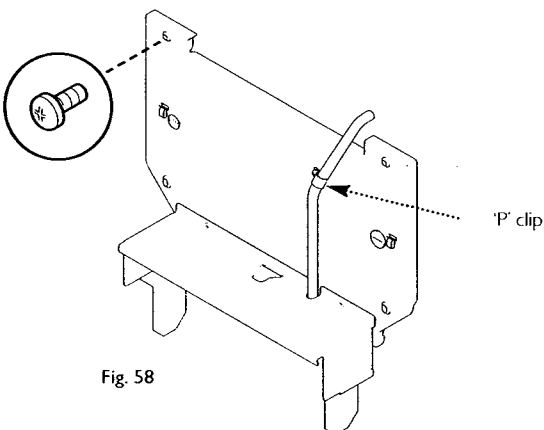

Fig. 58

## 9.0 Changing Components

### 9.8 Gas Valve

1. Remove controls heat shield from its retaining clips (Fig. 59).
2. Remove the screw on the gas valve lead and remove lead (Fig. 60).
3. Remove the three screws holding the burner feed pipe to the valve, being careful not to lose or damage the "O" ring seal (Fig. 60).
4. Undo the pilot feed pipe nut from the valve (Fig. 60).
5. Remove the two screws holding the valve to the controls mounting bracket adjacent to the union nut and tailpiece (Fig. 60).
6. Remove the support bracket screw.
7. Remove the valve from the controls mounting bracket (Fig. 60).
8. Remove the tailpiece and union nut from the original valve and fit to the new one (Fig. 60).
9. Remove the support bracket.
10. Reassemble in reverse order.

### 9.9 Burner & Main Injector

1. Remove the lint arrester by pulling forward (Fig. 61).
2. Remove the four hexagon headed screws holding the burner to the mounting plate (Fig. 62).
3. If required the main injector can be unscrewed from the feed pipe and replaced. The copper sealing washer must be retained for re-use or replace if damaged (Fig. 62).
4. Reassemble in reverse order.

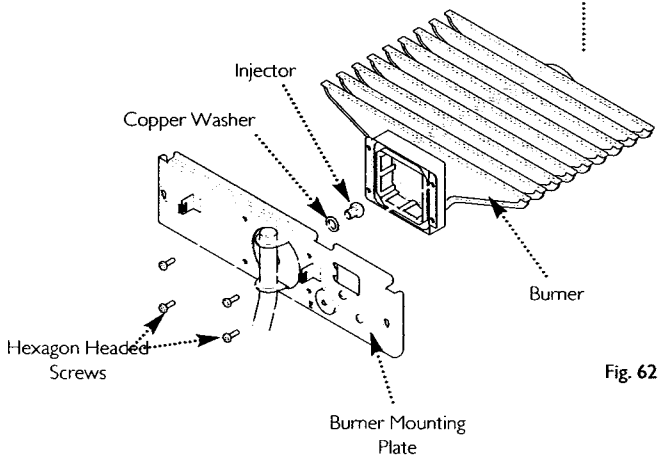
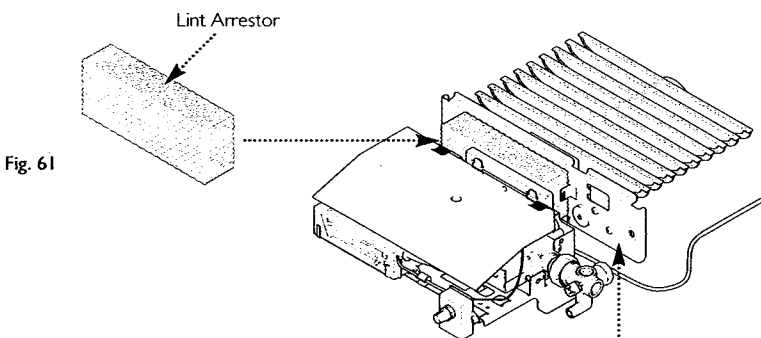
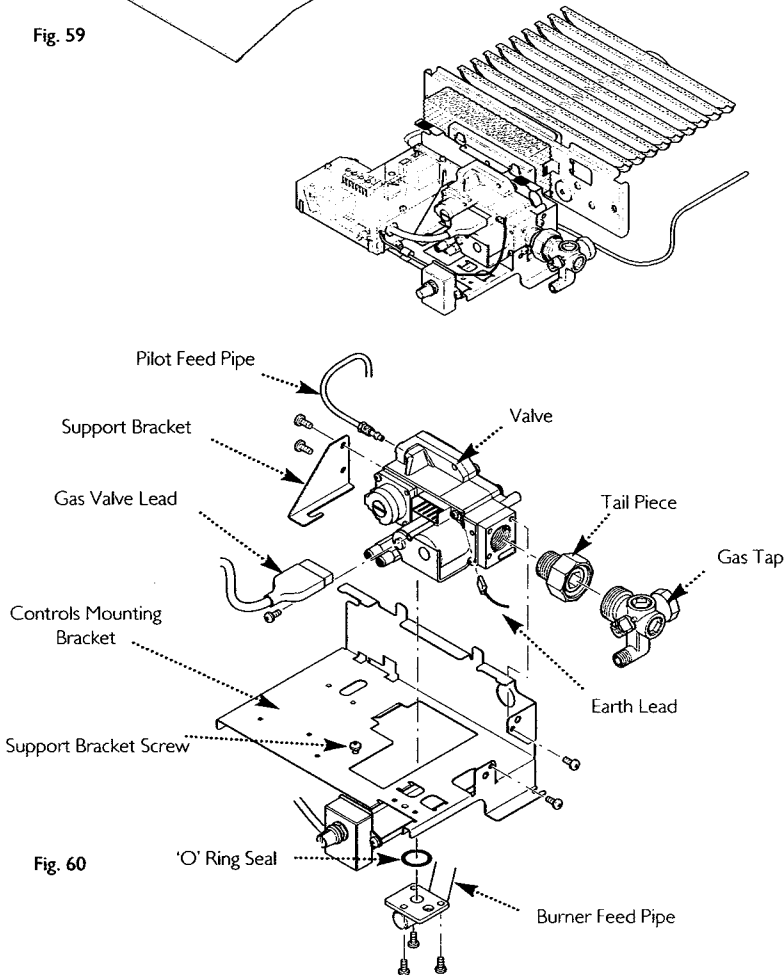
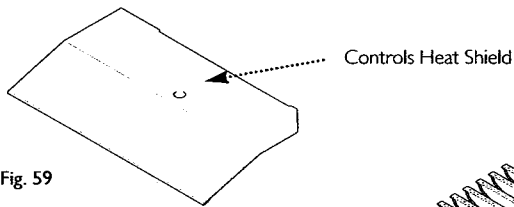

## 9.0 Changing Components

### 9.10 Pilot/A.S.D. Assembly

**WARNING:** The Pilot/A.S.D. Assembly should not be adjusted in anyway. The A.S.D. must not be altered so that it will not operate or be bypassed in anyway. The complete assembly must be replaced in the event of one or other component failure(s). Only use a Genuine Baxi Spare Part.

Fig. 63

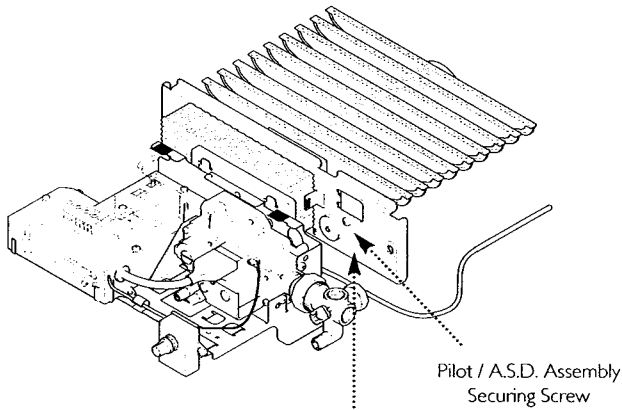
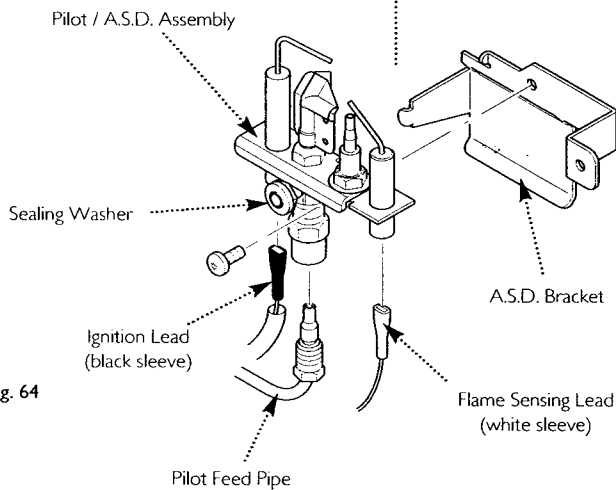

Fig. 64



1. Remove the ignition and sensing leads from the A.S.D. electrodes (Fig. 64). Undo the pilot feed pipe at the A.S.D. (Fig. 64).

2. Undo the screw holding the A.S.D. bracket to the burner mounting plate and disengage the tab on the bracket from the plate. Undo the screw holding the A.S.D. to its bracket (Fig. 63 & 64).

3. Fit the new A.S.D. onto the bracket (Fig. 64) and connect the ignition and sensing leads to their electrodes.

4. Engage the tab on the A.S.D. bracket in the hole in the burner mounting plate. Ensure that the pilot aeration tube seal sits in the recess in the sensing pipe adaptor. Refit the retaining screw.

5. Reassemble in reverse order.

### 9.11 Ignition Lead

1. Remove controls heat shield from its retaining clips.

2. Remove the three screws securing the controls box cover and remove the electrode lead from its terminal on the PCB and the electrode. The lead has a black sleeve at the electrode end (Fig. 64 & 65).

3. Reassemble in reverse order.

### 9.12 Flame Sensing Lead

1. Remove controls heat shield from its retaining clips.

2. Remove the three screws securing the controls box cover and remove the electrode lead from its terminal on the PCB and at the sensing probe end. The lead has a white sleeve (Fig. 64 & 65).

3. Reassemble in reverse order.

Fig. 65

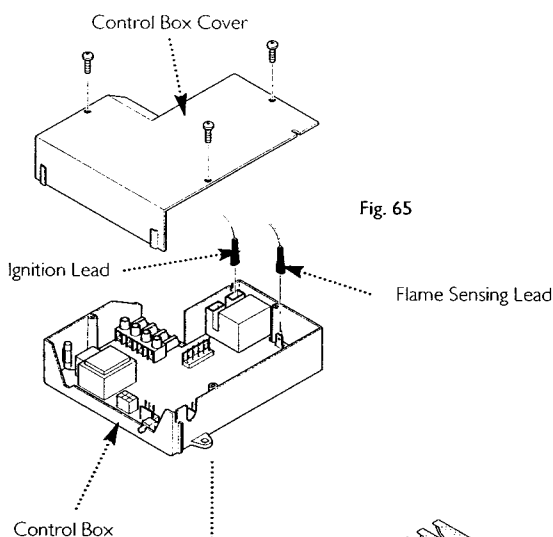
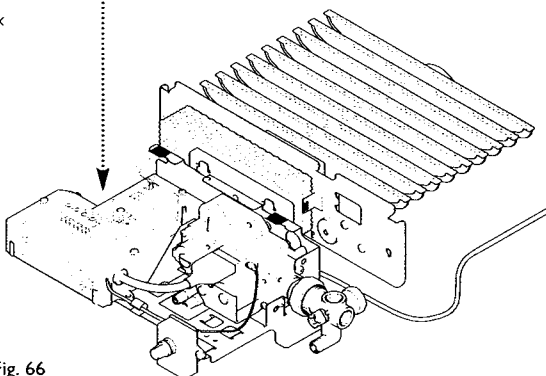

Fig. 66



Before starting **FAULT FINDING** carry out preliminary electrical system checks i.e. Earth Continuity, Polarity, Short Circuit and Resistance to Earth.

## 10.0 Fault Finding

**WARNING:** Where practicable fault finding should be performed with the main electricity supply **ISOLATED**.

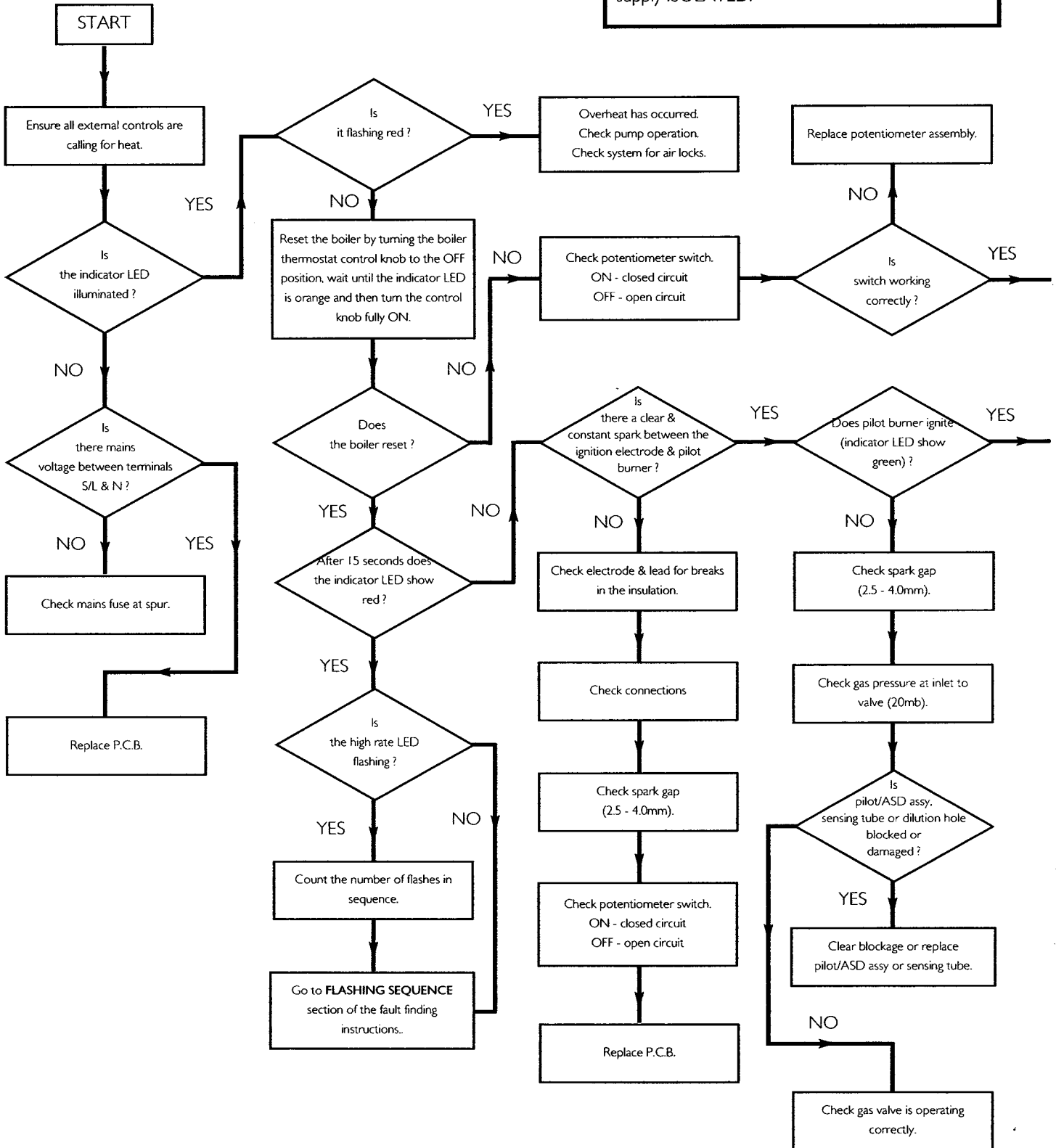

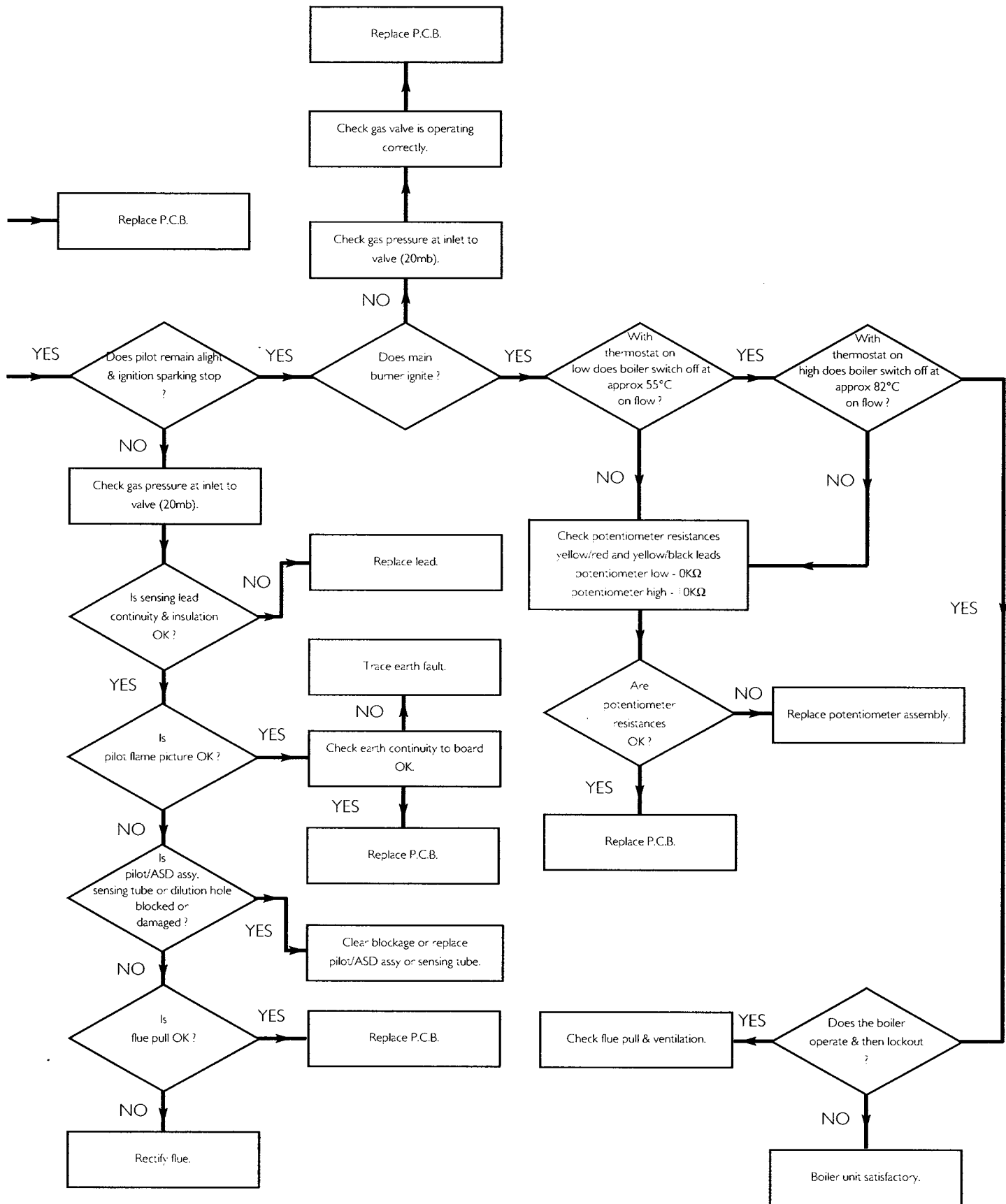

Flashing Sequence

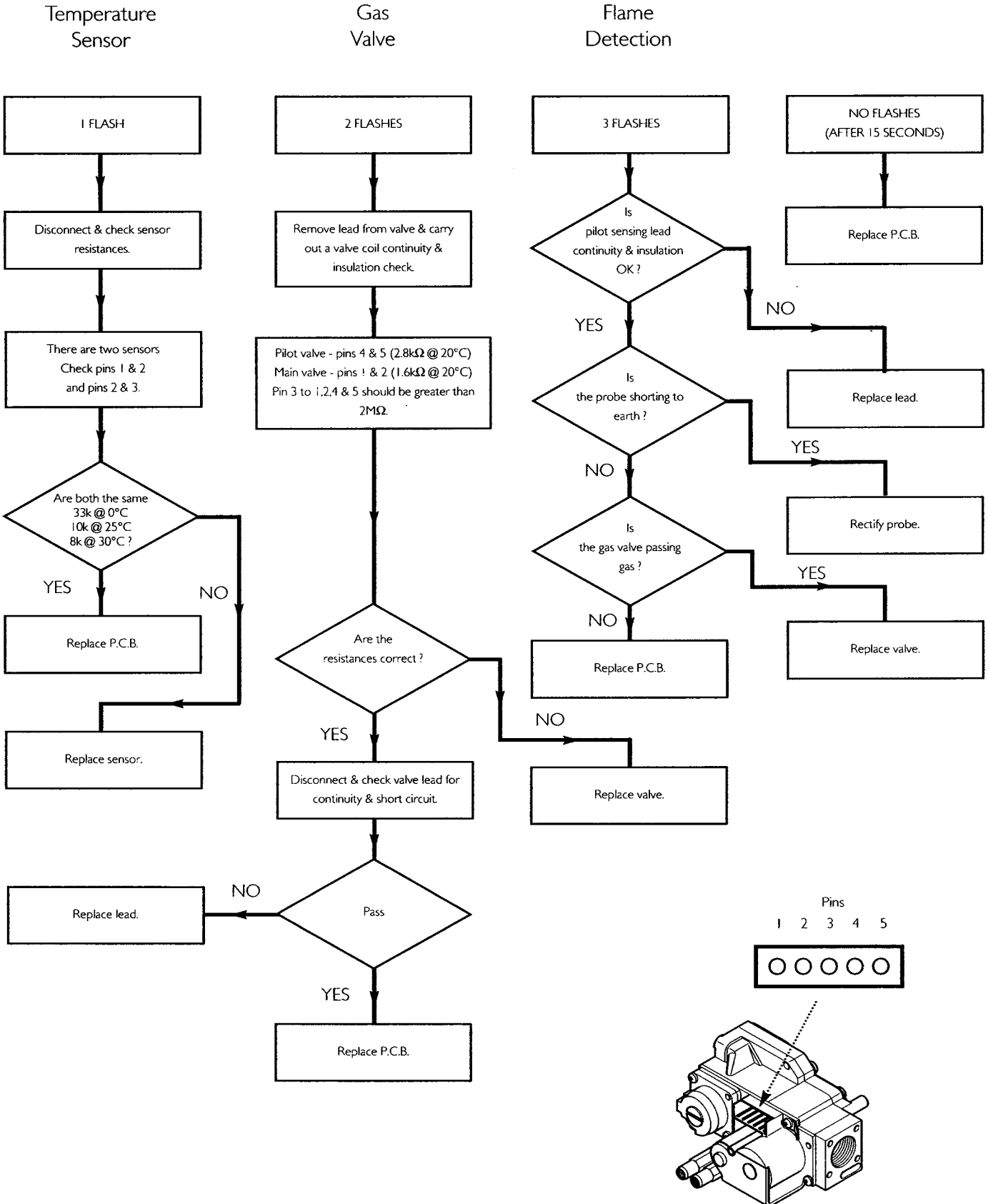



## 11.0 Short parts list

### Short Parts List

Key No.	G.C. No.	Description	Manufacturers Part No.
A	E94 896	Bumer Assy	249671
B	E94 897	Injector B5I	5107541
C	E00-121	Ignition Lead	237811
D	E00-122	Sensing Lead	237812
E	E94 892	Gas Valve	5107802
F	E00 133	Pilot/A.S.D. Assembly	238292
G	E94 893	P.C.B	5106472
H	E94 894	Potentiometer & Leads	5107803
J	E94 895	Thermostat Sensor	5106471

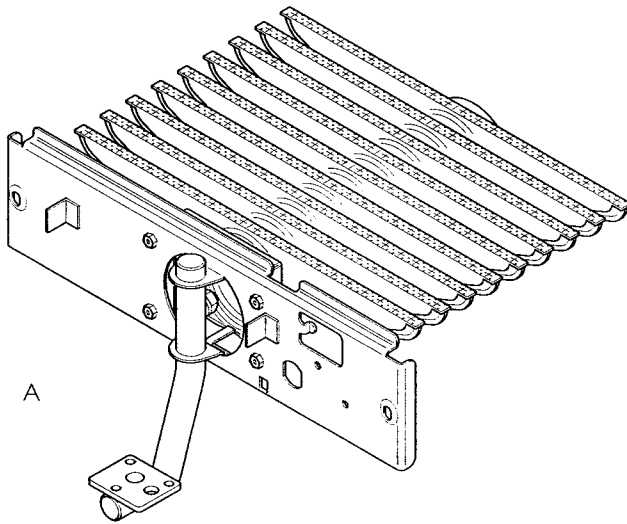

A



B



C



D

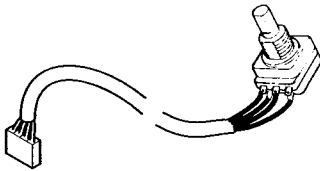

H

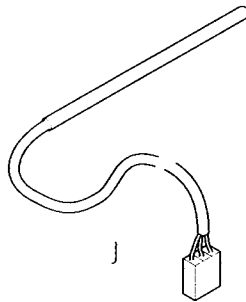

J

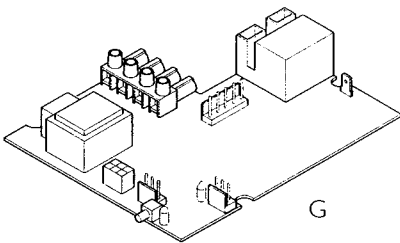

G

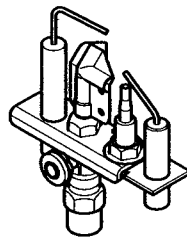

F

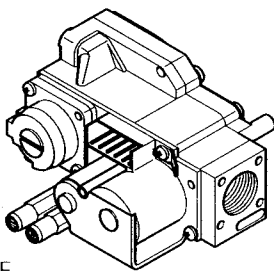

E



# GAS BOILER COMMISSIONING CHECKLIST

**BOILER SERIAL No.** \_\_\_\_\_ **NOTIFICATION No.** \_\_\_\_\_

**CONTROLS** To comply with the Building Regulations, each section must have a tick in one or other of the boxes

TIME & TEMPERATURE CONTROL TO HEATING	ROOM T/STAT & PROGRAMMER/TIMER <input type="checkbox"/>	PROGRAMMABLE ROOMSTAT <input type="checkbox"/>
TIME & TEMPERATURE CONTROL TO HOT WATER	CYLINDER T/STAT & PROGRAMMER/TIMER <input type="checkbox"/>	COMBI BOILER <input type="checkbox"/>
HEATING ZONE VALVES	FITTED <input type="checkbox"/>	NOT REQUIRED <input type="checkbox"/>
HOT WATER ZONE VALVES	FITTED <input type="checkbox"/>	NOT REQUIRED <input type="checkbox"/>
THERMOSTATIC RADIATOR VALVES	FITTED <input type="checkbox"/>	
AUTOMATIC BYPASS TO SYSTEM	FITTED <input type="checkbox"/>	NOT REQUIRED <input type="checkbox"/>

**FOR ALL BOILERS CONFIRM THE FOLLOWING**

THE SYSTEM HAS BEEN FLUSHED IN ACCORDANCE WITH THE BOILER MANUFACTURER'S INSTRUCTIONS?

THE SYSTEM CLEANER USED \_\_\_\_\_

THE INHIBITOR USED \_\_\_\_\_

**FOR THE CENTRAL HEATING MODE, MEASURE & RECORD**

GAS RATE \_\_\_\_\_ m<sup>3</sup>/hr \_\_\_\_\_ ft<sup>3</sup>/hr

BURNER OPERATING PRESSURE (IF APPLICABLE)  N/A \_\_\_\_\_ mbar

CENTRAL HEATING FLOW TEMPERATURE \_\_\_\_\_ °C

CENTRAL HEATING RETURN TEMPERATURE \_\_\_\_\_ °C

**FOR COMBINATION BOILERS ONLY**

HAS A WATER SCALE REDUCER BEEN FITTED? YES  NO

WHAT TYPE OF SCALE REDUCER HAS BEEN FITTED? \_\_\_\_\_

**FOR THE DOMESTIC HOT WATER MODE, MEASURE & RECORD**

GAS RATE \_\_\_\_\_ m<sup>3</sup>/hr \_\_\_\_\_ ft<sup>3</sup>/hr

MAXIMUM BURNER OPERATING PRESSURE (IF APPLICABLE)  N/A \_\_\_\_\_ mbar

COLD WATER INLET TEMPERATURE \_\_\_\_\_ °C

HOT WATER OUTLET TEMPERATURE \_\_\_\_\_ °C

WATER FLOW RATE \_\_\_\_\_ lts/min

**FOR CONDENSING BOILERS ONLY CONFIRM THE FOLLOWING**

THE CONDENSATE DRAIN HAS BEEN INSTALLED IN ACCORDANCE WITH THE MANUFACTURER'S INSTRUCTIONS? YES

**FOR ALL INSTALLATIONS CONFIRM THE FOLLOWING**

THE HEATING AND HOT WATER SYSTEM COMPLIES WITH CURRENT BUILDING REGULATIONS

THE APPLIANCE AND ASSOCIATED EQUIPMENT HAS BEEN INSTALLED AND COMMISSIONED IN ACCORDANCE WITH THE MANUFACTURER'S INSTRUCTIONS

IF REQUIRED BY THE MANUFACTURER, HAVE YOU RECORDED A CO/CO<sub>2</sub> RATIO READING? N/A  YES \_\_\_\_\_ CO/CO<sub>2</sub> RATIO

THE OPERATION OF THE APPLIANCE AND SYSTEM CONTROLS HAVE BEEN DEMONSTRATED TO THE CUSTOMER

THE MANUFACTURER'S LITERATURE HAS BEEN LEFT WITH THE CUSTOMER

**COMMISSIONING ENG'S NAME** PRINT \_\_\_\_\_ **CORGI ID No.** \_\_\_\_\_

34 SIGN \_\_\_\_\_ DATE \_\_\_\_\_

# SERVICE INTERVAL RECORD

It is recommended that your heating system is serviced regularly  
and that you complete the appropriate Service Interval Record Below.

**Service Provider.** Before completing the appropriate Service Interval Record below, please ensure you have carried out the service as described in the boiler manufacturer's instructions. Always use the manufacturer's specified spare part when replacing all controls

## SERVICE 1 DATE

ENGINEER NAME

COMPANY NAME

TEL No.

CORGI ID CARD SERIAL No.

COMMENTS

SIGNATURE

## SERVICE 3 DATE

ENGINEER NAME

COMPANY NAME

TEL No.

CORGI ID CARD SERIAL No.

COMMENTS

SIGNATURE

## SERVICE 5 DATE

ENGINEER NAME

COMPANY NAME

TEL No.

CORGI ID CARD SERIAL No.

COMMENTS

SIGNATURE

## SERVICE 7 DATE

ENGINEER NAME

COMPANY NAME

TEL No.

CORGI ID CARD SERIAL No.

COMMENTS

SIGNATURE

## SERVICE 9 DATE

ENGINEER NAME

COMPANY NAME

TEL No.

CORGI ID CARD SERIAL No.

COMMENTS

SIGNATURE

## SERVICE 2 DATE

ENGINEER NAME

COMPANY NAME

TEL No.

CORGI ID CARD SERIAL No.

COMMENTS

SIGNATURE

## SERVICE 4 DATE

ENGINEER NAME

COMPANY NAME

TEL No.

CORGI ID CARD SERIAL No.

COMMENTS

SIGNATURE

## SERVICE 6 DATE

ENGINEER NAME

COMPANY NAME

TEL No.

CORGI ID CARD SERIAL No.

COMMENTS

SIGNATURE

## SERVICE 8 DATE

ENGINEER NAME

COMPANY NAME

TEL No.

CORGI ID CARD SERIAL No.

COMMENTS

SIGNATURE

## SERVICE 10 DATE

ENGINEER NAME

COMPANY NAME

TEL No.

CORGI ID CARD SERIAL No.

COMMENTS

SIGNATURE

When contacting Baxi Potterton please have the following information to hand:

Appliance Name  
Model Number  
Serial Number

A label giving these details is situated on the Control Box.

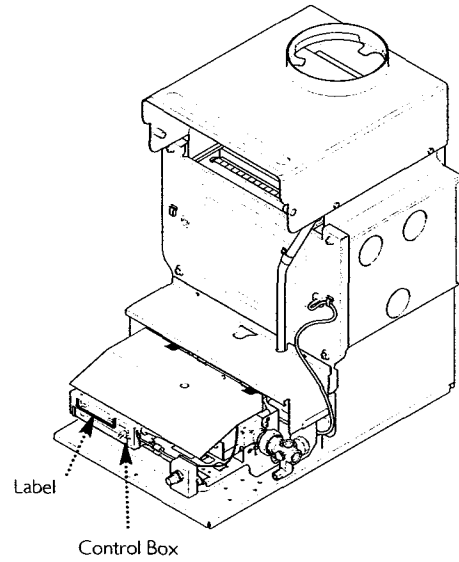

**BAXI POTTERTON**

A Trading Division of Baxi Heating UK Ltd  
Brownedge Road Bamber Bridge Preston Lancashire PR5 6UP  
After Sales Service 08706 096 096 Technical Enquiries 08706 049 049  
Website [www.baxi.co.uk](http://www.baxi.co.uk)

A **BAXI GROUP** company

Comp N° 5107278 - Iss 1 - 3/05