

# Installation & Servicing Instructions



Boiler	G.C No
E 22S	41-310-12
E 32S	41-310-13
E 22C	47-310-13
E 32C	47-310-14

**CE PIN 0063BR3405**

**These instructions to be retained by user.**

## Explanations of symbols and signs on the Control Tower display.

### Operation indication

(in the first display position of technical read out)

0	No heat requirement
1	Ventilation phase
2	Ignition phase
3	Burner active on central heating
4	Burner active on hot water
5	Fan check
6	Burner off when room thermostat is demanding
7	Pump overrun phase for central heating
8	Pump overrun phase for hot water
9	Burner off because of too high flow water temperature
R	Automatic venting program

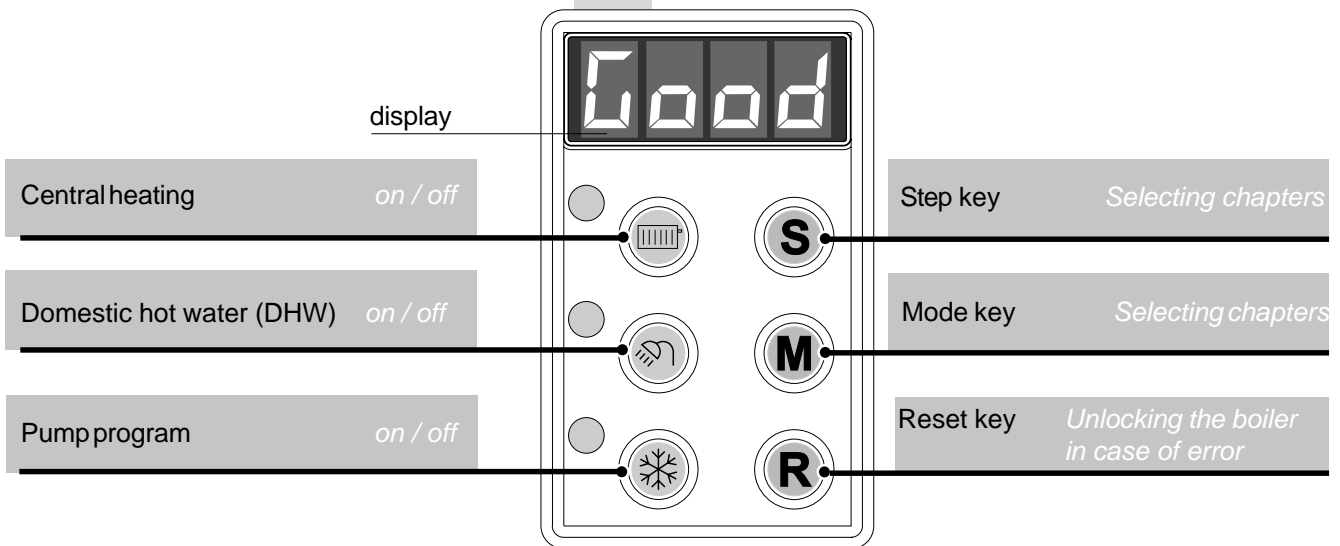

**From "Good" read-out to Technical read out (and vice versa):**  
**- Press STEP key for 5 sec.**

**FILL**

Water pressure is too low (<0,7 bar), FILL indication remains continuously visible, the boiler is taken out of operation. The installation needs to be topped up.



Water pressure is too low (<1,0 bar), flashing FILL will alternate with indication of water pressure, boiler power of 50% is possible. The installation needs to be topped up.

**HIGH**

Water pressure is too high (>2,8 bar), if HIGH indication remains continuously visible, the boiler is taken out of operation. The installation pressure needs to be decreased by draining water.

# Content

1	Introduction .....	4
2	Regulations .....	4
3	Scope of the supply .....	6
4	Description of the boiler .....	6
5	Mounting the boiler .....	6
5.1	Dimensions .....	7
6	Connecting the boiler .....	9
6.1	Central heating system .....	9
6.2	Expansion vessel .....	11
6.3	Underfloor heating system (plastic pipes) .....	12
6.4	Gas connection .....	12
6.5	Hot water supply .....	12
6.6	Condensation drain pipe .....	13
6.7	Flue gas exhaust system and air supply system .....	14
6.7.1	Dimensions of the flue gas and air intake duct .....	17
7	External hot water cylinders .....	18
8	Electrical connection .....	19
9	Boiler controls .....	21
9.1	Explanation of the function keys .....	22
10	Filling and venting the boiler and installation .....	23
10.1	Hot water supply .....	23
11	Commissioning the boiler .....	24
11.1	Central heating system .....	24
11.2	Hot water supply .....	24
11.3	Adjustments .....	25
11.4	Activating factory settings (green key function) .....	27
12	Isolating the boiler .....	28
13	Commissioning .....	28
13.1	Checking for contamination .....	28
13.2	Checking of the zero pressure control .....	29
13.3	Checking the CO <sub>2</sub> .....	30
14	Maintenance .....	31
14.1	Frequency of maintenance .....	31
14.2	Maintenance activities .....	32
14.3	Warranty .....	32
15	Technical specifications .....	33
16	Parts of the boiler .....	34
17	Installation examples .....	35
17.1	Radiator installation without thermostatic radiator valves .....	35
17.2	Radiator installation with underfloor heating zone .....	36
18	Error indication .....	37
19	Declaration of conformity .....	38
20	KIWA Certificate .....	39



**The appliance should only be installed by a Competent Gas Installer. Work on the boiler must be carried out by a competent person, (Ref: Gas Safety Installation and Use Regulations) using correctly calibrated instruments with current test certification.**

# 1 Introduction

These instructions describe the functioning, installation, use and primary maintenance of ATAG central heating boilers for the United Kingdom and Ireland. Where necessary the different regulations for each country are separately described.

These instructions are intended for the use by Corgi registered installers or registered Bord Gais installers in connection with the installation and putting into operation of ATAG boilers. It is advisable to read these instructions thoroughly, well in advance of installation. Separate instructions for use are supplied with the boiler for users of ATAG central heating boilers. ATAG is not liable for the consequences of mistakes or shortcomings which have found their way into the installation instructions or user's manual. Further, ATAG reserves the right to alter its products without prior notification.



**When delivering the boiler, give the customer clear instructions concerning its use; present the customer with the user's manual and card.**

Each boiler is fitted with an identification plate. Consult the details on this plate to verify whether the boiler is compliant with its intended location, e.g.: gas type, power source and exhaust classification.

On completion of the installation the installer or commissioning engineer must fill out and complete the Benchmark commission section of the boiler log book and hand to customer or end user for future record keeping. The Benchmark log book must also be filled out and completed by the service agent following each service call, and returned to the customer. A copy of the Benchmark commissioning certificate must be returned to ATAG Heating UK Ltd along with the warranty registration card to register the appliance for the standard warranty benefits

Relevant Installation, Service and User manuals:

- ATAG Monopass                      Flue system guide
- ATAG BrainQ                        Digital room thermostat
- ATAG MadQ                         Cascade-/Zone controller

# 2 Regulations

The following regulations apply to installation of ATAG central heating boilers:

Legislation and Regulations.

Gas Safety (Installation and Use). All gas appliances must by law, be installed by a competent person, eg. Members of CORGI and in accordance with the current Gas Safety Regulation. Failure to install appliance correctly could lead to prosecution.

In addition to the above regulations this appliance must be installed in compliance with the current IEE Regulations, the Building Standards (Scotland Consolidation) Regulations. Regulations and bye laws of the Local Water Authority and the Current Health and Safety Regulation.

**Ireland:**

- Irish standard 813
- Domestic gas installations

The current, Electricity at Work Regulation must be complied with and also be in accordance with the relevant and current editions of the British Standards.

The ATAG E boiler is a certified appliance and must not be modified or installed in any way contrary to this Installation Manual.

Manufacturers instructions must not be taken in any way as overriding statutory obligations.

The ATAG E is a central heating boiler with an optional integrated hot water function. These boilers must be connected according to these instructions and all installation norms in respect of the part of the boiler to be connected.

Observe the following rules of safety:

- All work on the boiler must take place in a dry environment.
- ATAG boilers may never be in operation without their housing, except in connection with maintenance or adjustments (see Chapter 13 and 14).
- Never allow electrical or electronic components to come into contact with water.

Carry out the following tasks in connection with maintenance, etc. to an already-installed boiler:

- Shut down all programs
- Close the gas tap
- Remove the plug from the wall socket
- Close the stop cock of the boiler's intake connection

Take note of the following when maintenance or adjustments are needed:

- The boiler must be able to function during these activities; for this reason, the boiler's supply voltage, gas pressure and water pressure must be maintained. Ensure that there is not a source of potential danger during these activities.

**Following maintenance or other activities; always check the installation of all parts through which gas flows (using leak-search spray).**



**Following maintenance or other activities, always replace the housing and secure it with the screw behind the door at the front of the casing.**



The following (safety) symbols may be encountered in these installation instructions and on the boiler:



**This symbol indicates that the boiler must be stored away from frost.**



**This symbol indicates that the packaging and/or contents can be damaged as a result of insufficient care taken during transport.**



**This symbol indicates that, whilst still in its packaging, the boiler must be protected from weather conditions during transport and storage.**



**KEY-symbol. This symbol indicates that assembly or dismantling, must be carried out.**



**ATTENTION symbol. This symbol indicates that extra attention must be paid in connection with a particular operation.**



**Useful tip or advice**

### 3 Scope of the supply

The boiler is supplied ready for use. The supply kit is composed as follows:

- Boiler with casing;
- Automatic vent (inside the boiler);
- Safety valve (inside the boiler);
- Suspension bracket
- Expansion vessel (inside the boiler)
- Fixing material consisting of plugs and screws;
- Template;
- Installation instructions
- Operating manual;
- Warranty card;
- Benchmark logbook.

### 4 Description of the boiler

#### Room sealed boiler

The boiler retrieves its combustion air from the outside then discharges the flue gasses to the outside.

#### Condensing

Retrieves heat from the flue gasses. Water condensates on the heat exchanger.

#### Modulating

Higher or lower burning according to the heat demand.

#### Stainless Steel

Super solid kind of steel which keeps its quality for life. It will not rust or erode in contrast to composition materials, like aluminium.

The ATAG E boiler is a room sealed, condensing, modulating central heating boiler, with or without an integrated hot water facility.

The boiler is provided with a compact stainless steel heat exchanger with smooth tubes. A well thought out principal using durable materials.

The boiler burns gas for supplying warmth. The heat is transferred in the heat exchanger to the water in the central heating system. By cooling down the flue gasses condensate is formed. This results in high efficiency. The condensate, which has no effect on the heat exchanger and the function of the boiler, is drained through an internal siphon.

The boiler is provided with an intelligent control system (CMS Control Management System). The boiler anticipates the heat demand of the central heating system or the hot water facility.

When an outside sensor is connected, the boiler works weather dependantly. This means that the boiler control measures the outside temperature and flow temperature. With this data the boiler calculates the optimal flow temperature for the installation.

Explanation of the type indication: ATAG E 22C

E = Type

22 = Nominal load in kW

C = Combi (S = Solo)

The boiler has been tested according to valid CE\* standards and has a CE\* certificate and SEDBUK A-rating.

Statement: No banned materials including asbestos, mercury, CFC's have or will not be included in the product.

A

## 5 Mounting the boiler

The room where the boiler will be placed must always be frost free. The boiler casing is splash water tight (IPX4D) and is suitable to be installed in e.g. a bathroom.

It is NOT necessary to have a purpose provided air vent in the room or internal space in which the boiler is installed. Neither is it necessary to ventilate a cupboard or compartment in which the boiler is installed, due to the extremely low surface temperature of the boiler casing during operation. Therefore the requirements of BS 6798, Clause 12, and BS5440:2 may be disregarded.

The boiler can be mounted practically to any wall with the suspension bracket and the enclosed fixing equipment. The wall must be flat and of sufficient strength in order to be able to carry the boiler weight with its water content.

Above the boiler there must be at least 250 mm working space in order to be able to fit a coaxial flue system or a twin supply. On the left side of the boiler at least 50 mm and on the right side 10 mm must be reserved to allow fitting or removing of casing. The location of the boiler can be determined by using the template.

Remove the casing of the boiler. The casing is also the airbox of the boiler and is secured with a screw behind the door at the front. Also the four quick-release fasteners (2 at the top and 2 at the bottom) should be secured with a screw.



**First remove the screws before loosening the quick-release fasteners. Tighten the screws again when replacing the housing.**

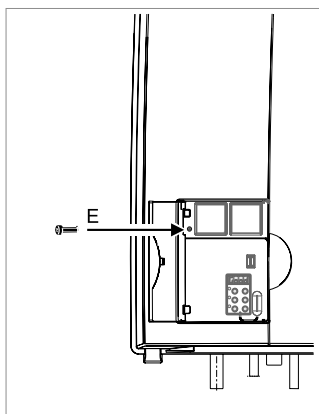

Removing the casing

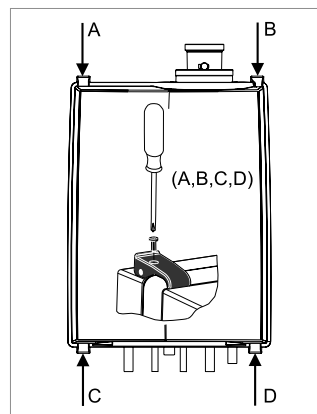

figure 1



**Lift the boiler only by the boilers rear wall.**

### Lifting and carrying precautions:

- Lift only a manageable weight, or ask for help.
- When lifting the boiler, bend the knees, and keep the back straight and feet apart.
- Do not lift and twist at the same time.
- Lift and carry the boiler close to the body.
- Wear protective clothing and gloves to protect from any sharp edges.

## 5.1 Dimensions

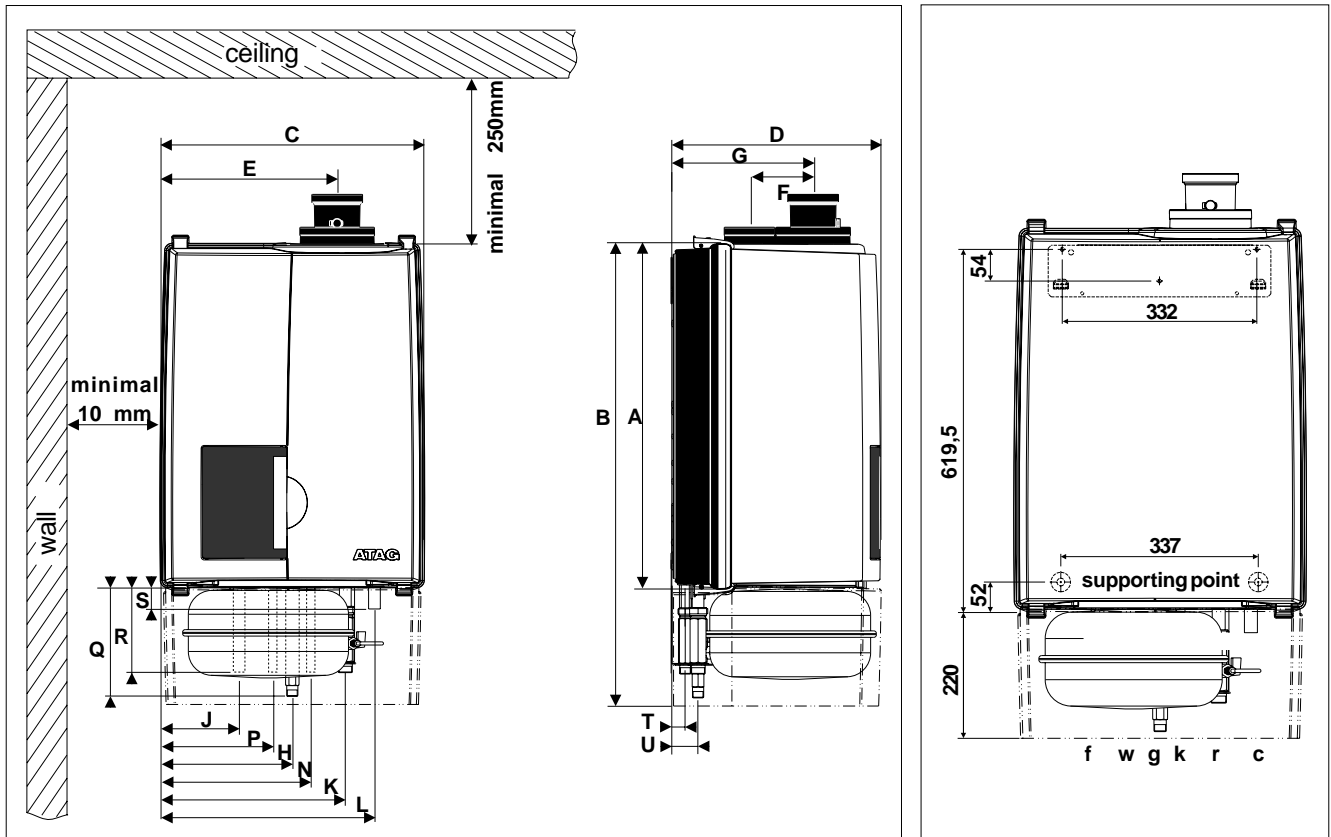

dimensions (in mm)

figure 1 boiler connections/mounting points

figure 3

type of unit	E22S	E22C	E32S	E32C
<b>A</b> height	mm 650	650	650	650
<b>B</b> height with expansion vessel	mm -	-	870	870
<b>C</b> width	mm 500	500	500	500
<b>D</b> depth	mm 395	395	395	395
<b>E</b> left side / flue gas exhaust	mm 335	335	335	335
<b>F</b> centre to centre / flue - airintake	mm 120	120	120	120
<b>G</b> back / flue gas exhaust	mm 270	270	270	270
<b>H</b> left side / gas pipe	mm 250	250	250	250
<b>J</b> left side / flow pipe	mm 150	150	150	150
<b>K</b> left side / return pipe	mm 350	350	350	350
<b>L</b> left side / condensation pipe	mm 405	405	405	405
<b>N</b> left side / cold water pipe	mm	285		285
<b>P</b> left side / hot water pipe	mm	215		215
<b>Q</b> pipe length of g*	mm 19	19	215	215
<b>R</b> pipe length of c*	mm 40	40	40	40
<b>S</b> pipe length of c and f; r; k and w*	mm 50	50	160	160
<b>T</b> back / centre of pipe c; k and w*	mm 26	26	26	26
<b>U</b> back / centre of pipe f; g and r*	mm 50	50	50	50

dimensions

table 1

type of unit	E22S	E22C	E32S	E32C
<b>air supply / flue gas system</b>	mm 60 / 100	60 / 100	60 / 100	60 / 100
<b>gas pipe - g</b>	1/2" female	1/2" female	1/2" female	1/2" female
<b>central heating flow pipe - f</b>	22 mm	22 mm	3/4" ext.	3/4" ext.
<b>central heating return pipe - r</b>	22 mm	22 mm	3/4" ext.	3/4" ext.
<b>condensation discharge pipe - c</b>	22 mm	22 mm	22 mm	22 mm
<b>cold water pipe - k</b>		15 mm		1/2" ext.
<b>hot water pipe - w</b>		15 mm		1/2" ext.

connection diameters

table 2



## 6 Connecting the boiler

The boiler has the following connection pipes;

- The central heating pipes.  
*These can be connected to the installation by means of compression fittings / adapter fittings;*
- The gas pipe.  
*It is provided with a female thread into which the tail piece of the gas valve can be screwed;*
- The condensation drain pipe.  
*It consists of a 22mm plastic pipe. The drain pipe can be connected to this by means of an open connection. If the open connection is fitted in a different location, then the pipe can be lengthened by means of a 32 mm PVC sleeve;*
- The flue gas exhaust system and air supply system.  
*It consists of a concentric connection 60/100 mm.*
- Cold and hot water pipes.  
**Only Combi boilers:** *These consist of 15 mm copper pipe and can be connected to the installation by means of compression fittings / adapter fittings.*



**It is recommended that isolation valves are fitted to all heating and hot water connections to facilitate ease of future maintenance.**



**It is advisable to spray-clean all of the boiler's connecting pipes and/or to spray-clean/blow-clean the installation before connecting it to the boiler.**

### 6.1 Central heating system

Connect the central heating system according to the actual regulations.

The boiler pipes can be connected to the installation by means of compression fittings. Reducers should be used for connecting to thick-walled pipe (welded or threaded).



**When removing the plastic sealing caps from the pipes, contaminated testing water may be released.**

The boiler has a self-adjusting and self-protecting control system for the load. By this means the temperature difference between the flow and return water is checked. Table 3 shows the water displacement which supplies the circulation pump at certain installation resistance.

type of unit	Pump type	water flow rate $\Delta T$ 20°C		permissible installation resistance	
		l/min	l/h	kPa	mbar
<b>E22S</b>	UPS 20-50	14,3	856	28	280
<b>E32S</b>	UP 20-60	20.7	1244	17	170
<b>E22C</b>	UPS 20-50	14,3	856	27	270
<b>E32C</b>	UP 20-60	20.7	1243	15	150

Installation resistance

table 3

If the installation resistance is higher than the stated value the load will be adjusted until an acceptable temperature difference between flow and return water has been obtained. If, after this, the temperature difference remains too much then the boiler will switch itself off and wait until an acceptable temperature has been reached.

If an unacceptable temperature is detected, then the control will repeatedly try to achieve water flow, and if this does not work then the boiler will switch off.

If the capacity of the boiler pump is insufficient, an extra external pump can be installed in combination with a low velocity header in series with the boiler. The electrical side of this external circulation pump can be connected in the Control Tower, by means of an optional cable tree, which can be ordered separately (art.nr. S4643900). The external pump will switch at the same times as the boiler pump.

The maximum absorbed current consumption of the external circulation pump may be 230 W (1 Amp). The extra external pump must be selected according to the installation resistance and the required flow.

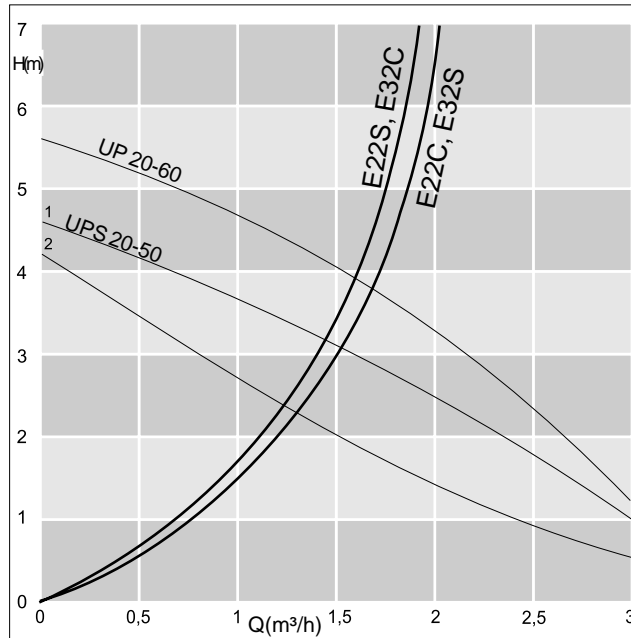

pump index lines

graph 1

As standard the boiler is provided with a water filter in the return pipe of the boiler. With this, possible contamination of the central heating water is prevented from ending up in the boiler. The boiler is also provided with an internal safety valve set at 3 bar. This is connected to the waste discharge together with the condensation discharge.

If all, or a large part of the radiators are provided with thermostatic radiator valves it is advisable to use a pressure difference control (bypass) in order to prevent flow problems in the installation.



**The boiler is designed to be used on a sealed system only.**



**Additives in the installation water are only permitted in consultation with the country distributor. ATAG Heating UK Ltd recommend the use of either Fernox or Sentinel products.**

## 6.2 Expansion vessel

All ATAG E-Series boilers are provided with an internal expansion vessel. The vessel of the E22S and E22C is positioned inside the boiler casing. This expansion vessel has a pre-charge pressure of 1 bar and a capacity of 8 litres. The vessel of the E32S and E32C is positioned directly beneath the boiler and together with the casing forms a single entity with the boiler. The expansion vessel is located vertically behind the casing, which can be removed by pulling forwards. The expansion vessel has a pre-charge pressure of 1 bar and a capacity of 12 litres. If a larger capacity expansion vessel is needed for the installation a standard expansion vessel should be fitted additionally.

If the internal expansion vessel is not sufficient, choose an expansion vessel volume, of which the summary is geared to the installation's water capacity. The pre-charge pressure depends on the installation height above the expansion vessel (Table 4). Fit the expansion vessel into the return pipe as close as possible to the boiler.

installation height above the expansion vessel	pre-charge pressure of the expansion vessel
5 m	0,5 bar
10 m	1,0 bar
15 m	1,5 bar

choice of expansion vessel

table 4

## 6.3 Underfloor heating system (plastic pipes)

When connecting or using an underfloor heating system, designed with plastic pipes, or plastic pipes are used elsewhere in the installation, one should ensure that the plastic pipes used comply with the DIN 4726/4729 standard. It is set out in this standard that the pipes may not have oxygen permeability higher than 0.1 g/m<sup>3</sup>.d at 40°C. If the system does not comply with this DIN standard, the underfloor heating component will have to be separated from the central heating appliance by means of a plate exchanger.



**No recourse can be made to the terms of the warranty in the event of failure to observe the regulations pertaining to plastic underfloor heating pipes.**

## 6.4 Gas connection

The appliance pipe is fitted with an internal thread, into which the tail piece of the gas tap can be screwed.

### **United Kingdom:**

The gas supply must comply to the current Gas Safety, Installation & Use Regulations.

### **Ireland:**

- Irish standard 813
- Domestic gas installations

The connection to the appliance must include a suitable method of disconnection and a gas control cock must be installed adjacent to the appliance for isolation purposes. The nominal inlet working gas pressure measured at the appliance should be 20 mbar for Nat gas (G20).



**Make sure that the gas pipe work does not contain dirt, particularly with new pipes.**

When the boiler has to be converted from natural gas to LPG, ATAG provides special kits for this purpose. Special instructions are supplied with the kit.



**Always check the installation of all of the parts through which gas flows (using leak-search spray)**

## 6.5 Hot water supply

Connection of the drinking water installation should be done according to the national water laws.

The ATAG E combination boilers are fitted with a stainless steel plate heat exchanger for producing domestic hot water. The boiler does not have a hot water store and in case of a demand for hot water the boiler will heat the domestic water flowing through the plate heat exchanger up to 60°C instantaneous.

The water mains installation must comply with the British water regulations.



**In regions with a water hardness value higher than 267ppm (2,67 mmol/l), calcium deposits should be removed from the plate heat exchanger on a regular basis. If problems occur when using sanitary water with a chlorine content higher than 150 mg/l, no recourse can be made to the terms of the warranty.**

The hardness of the water is variable in Great Britain and Ireland. The water company can provide exact information about this.

The domestic water pipes can be connected to the installation by means of compression fittings / adapter fittings. The cold water inlet on the Combi boilers must be provided with the following (counted in the water flow direction):

- Dosing valve (supplied),
- Safety group,
- Expansion vessel 6bar (potable water, blue).

A dosing valve must be fitted in the cold water pipe. The dosing valve ensures that a quantity of water is supplied which has a guaranteed outlet temperature of 60°C (assuming a cold water temperature of 10°C). The quantity of water is virtually unaffected by the water pressure.



With a water pressure lower than 1.5 bar it is advisable to remove the inside mechanism of the dosing valve.

## 6.6 Condensation drain pipe

ATAG boilers produce condensate. This condensate must be drained otherwise the boiler will not function.

The common condensation drain pipe should be connected to the drain by means of an tundish break connection. By this means the possibility of drain gases ending up in the boiler is prevented. The drain connection should have a minimum diameter of 32mm.

Connect the condensation drain pipe according to the actual regulations.

The following components are connected to the collective condensation drain pipe:

- Condensation discharge;
- Safety valve;



**Draining of the condensation water to the external rain guttering is not permitted in view of the danger of freezing.**



**Before putting the boiler into operation fill the siphon with 300 ml of water.**



The condensate pipe must be run using suitable corrosion resistant materials (eg. plastic).

## 6.7 Flue gas exhaust system and air supply system

The flue gas exhaust system and air supply system consists of:

- Flue gas pipe;
- Air supply pipe;
- Roof or wall terminal.

The flue gas exhaust system and air supply system must comply with:

### United Kingdom:

The flue gas outlet and air supply installation must comply with the current regulation requirements. IG UP 10 and BS 715.

### Ireland:

- Irish standard is 813 section 9.10.1

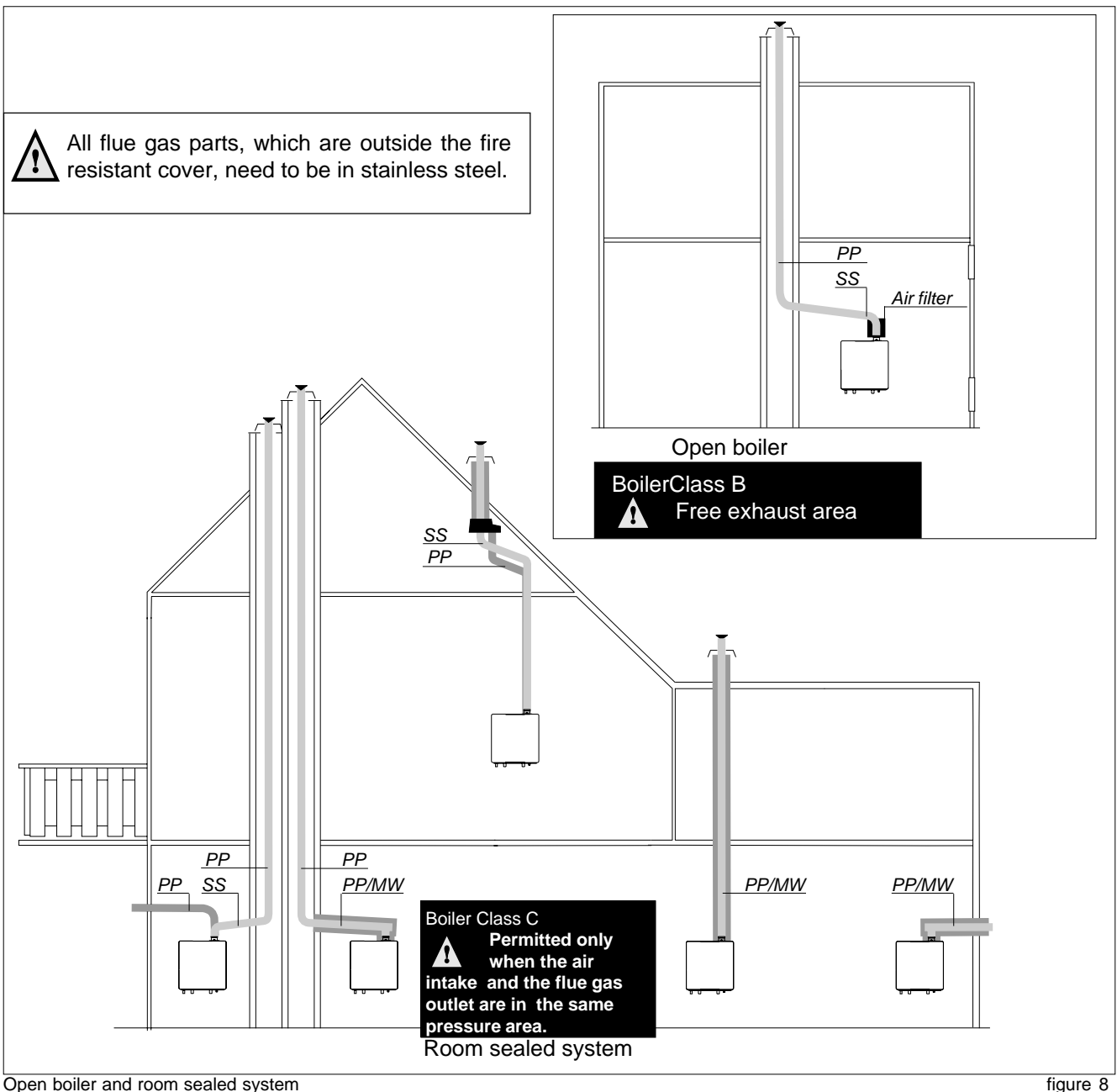

The appliance concentric connection diameter is 60/100 mm, to which the flue gas outlet and air supply system can be fitted, with or without elbow pieces. The maximum permissible pipe length is set out in Table 5.

It is also possible to use a parallel pipe connection of 2x 80mm. In this case the adapter 60/100 should be removed and a separate 125mm cover should be ordered. Art.nr. S4323410.



We suggest you design a simple flue gas system and air supply system using table 6. For further information about the available components of the flue gas and air supply system we recommend you consult the Monopass Flue system literature.

The ATAG flue gas system is meant and designed solely for the use on ATAG central heating boilers adjusted to Nat gas or LPG. The maximum flue gas temperatures are below 70°C (full load 80/60°C)

The proper operation can be influenced harmfully by changes of or adjustments to the correct set up.

Possible warranty claims will not be honoured if incorrect changes result in non compliance with the installation manual or local rules and regulations.

The flue gas systems described in this document are solely suited for ATAG central heating boilers of the ATAG boiler range. For this purpose the CE Certificate has been supplemented under the Gastec nr: 0063BR3405, 0063BQ3021, 0063AS3538 and 0063AU3110.

The flue gas system should be built up using only ATAG program products. Combinations with other brands or systems are without written permission from ATAG Heating is not permitted.

The terminal should be located where dispersal of combustion products is not unimpeded and with due regard for the damage or discolouration that might occur to parts of the building in the vicinity (see fig 9).

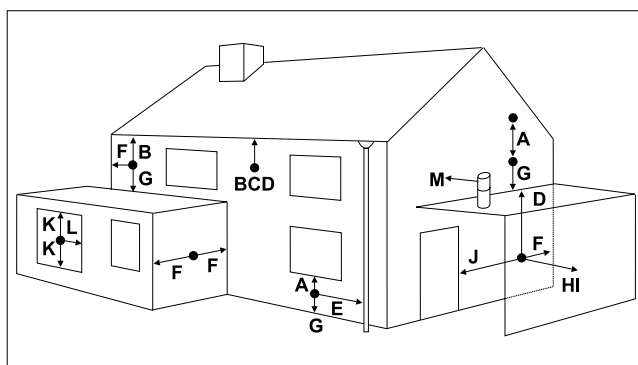

figure 9

terminal position for fan assisted boiler		minimum distance
A	directly below an open window or other opening (e.g. air brick)	mm 300
B	below gutters, soil pipes or drain pipes	mm 75
C	below eaves	mm 200
D	below balconies or car port roof	mm 200
E	from vertical drain pipes and soil pipes	mm 75
F	from internal or external corners	mm 300
G	above ground or below balcony level	mm 300
H	from a surface facing a terminal	mm 600
I	from a terminal facing a terminal	mm 1200
J	from an opening in the car port (e.g. door window) into dwelling	mm 1200
K	vertically from a terminal on the same wall	mm 1500
L	horizontally from a terminal on the same wall	mm 300
M	horizontally from a vertical terminal to a wall	mm 300

Dimensions

table 6

In certain weather conditions condensation may also accumulate on the outside of the air inlet pipe. Such conditions must be considered and where necessary insulation of the inlet pipe may be required.

In cold and/or humid weather water vapour may condense on leaving the flue terminal. The effect of such 'plumeing' must be considered.

The terminal must not be located in a place where it is likely to cause a nuisance. For protection of combustibles, refer to IS 813 section 9.10.1. where the terminal is less than 2m (6.6ft) above a pavement or platform to which people have access (including) any balcony or flat roof. The terminal must be protected by a guard of durable material. A suitable guard is available from the country distributor.



**Where a terminal is fitted below a window which is hinged at the top, and where the hinge axis is horizontal, and the window opens outwards, the terminal shall be 1m below the bottom of the window opening.**



**If the boiler is to be located under stairs, a smoke alarm meeting the requirements of I.S. 409 or equivalent must be fitted.**



**The flue must be terminated in a place not likely to cause a nuisance.**

For horizontal sections, the outlet system should always be fitted on an incline (50 mm/m) sloping down towards the appliance so that no condensation water is able to accumulate in the outlet system. The chances of icicles forming on the roof outlet is minimised by causing the condensation water to run back towards the appliance. In the case of horizontal outlets the inlet system should be fitted on an incline sloping down towards the outside to prevent rainwater from coming in.

The appliance produces a white wisp of condensation (plumeing). This wisp of condensation is harmless, but can be unattractive, particularly in the case of outlets in outside walls.

At this time there are 2 different ways of connecting the flue gas/air intake system. The flue gas duct for the 60/100, 80/125 and 100/150 are push fit connections, see figure 10. The air intake for the 60/100 is a clamp ring connection. These two types are not interchangeable.

Cutting the pipe goes as follows:

- Take out the inner tube by turning it until it releases from its security position;
- Cut just as much from the air intake part as from the flue gas part;
- Take off the burrs from the cutting edge to prevent cutting the seals;
- Click the pipes back together again.

Use special grease to simplify the fitting

When mounting the flue gas system, pay attention to the flow direction. An arrow on the product points this out. It is not permitted to mount a system upside down and will lead to complaints.

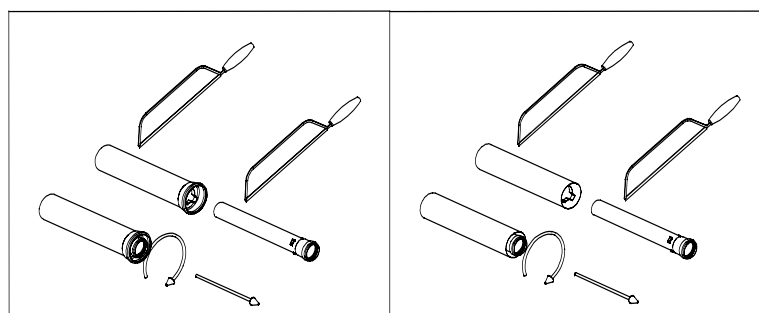
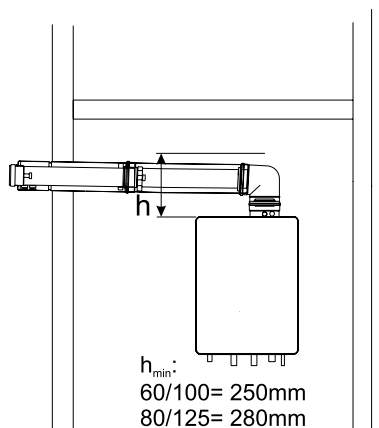

Dismantlement and shorten pipes

figure 11



## 6.7.1 Dimensioning of the flue gas and air intake duct

The flue diameter is determined by the total length of the run, including for the connection pipe, elbows fittings and terminal covers etc and the type and number of boilers installed into the system.

An undersized flue pipe can lead to disorders. Look at table 1 for the choice of the system and the correct diameter. The table below shows the maximum flue lengths with the different boiler outputs. A longer flue gas length can be achieved by increasing the diameter to  $\varnothing$  100mm.

Explanation table 1:

Two pipe flue gas system: maximum noted length = distance between boiler and roof terminal A

Concentric flue gas system: maximum noted length = distance between boiler and roof terminal B

When using bends the noted value behind every bend should be deducted from the maximum straight length.

Example:

A 22kW with a concentric flue gas system  $\varnothing$ 60/100mm has according to the table a maximum flue straight length of 12m. In the system that is going to be put in there are 2 x 45° bends, so the maximum flue gas length is  $12 - (2 \times -1) = 10$  meters.

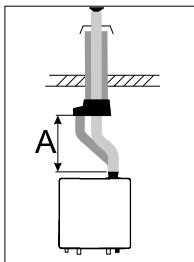

Two pipe flue system + chimney lining			
		$\varnothing$ 80mm	A in m
E22S E22C		Maximum straight length 80	30
		87° bend resistance length	-1,5
		45° bend resistance length	-0,8
E32S E32C		Maximum straight length 80	24
		87° bend resistance length	-1,5
		45° bend resistance length	-0,8

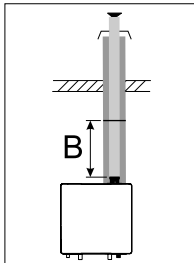

Concentric flue system					
		B in m	$\varnothing$ 60/100mm	B in m	
E22S E22C		Maximum straight length 80/125	30	Maximum straight length 60/100	12
		87° bend resistance length	6	87° bend resistance length	-1
		45° bend resistance length	-2,8	45° bend resistance length	-1
E32S E32C		Maximum straight length 80/125	24	Maximum straight length 60/100	8
		87° bend resistance length	0	87° bend resistance length	-1
		45° bend resistance length	0	45° bend resistance length	-1

Dimensions flue gas system and air supply system

Table 5

## 7 External hot water cylinders

Depending of the comfort preferences different external hot water cylinders can be connected to the boiler. The choice of the cylinder depends on the coil output. The coil output must comply with the boiler output.

The E-Series are provided with an internal DHW control. The electrical connection can be made on the connection terminal in the Control Tower. See the wiring diagram on page 19 and 20.

## 8 Electrical connection

The appliance complies with the CE Machinery Directive 89/392/EEC. The EC Low Voltage Directive 72/23/EEC and the EC EMC Directive 89/336/EEC.

A 230V -50Hz mains electrical supply is required fused externally at 5A.

The installation must continue to comply with:

**United Kingdom:**

- the national rules for electrical installations.

**Ireland:**

- the ECTI national rules for electrical installations

The appliance must be connected to an earthed socket. this must be visible and within reach.

The following general stipulations also apply:

- No changes may be made to the wiring of the appliance;
- All connections should be designed in accordance with the enclosed regulations.;
- Should it be necessary to change it, the mains power supply cable may only be replaced with an ATAG mains power supply cable (item No. S4477300).

**The ATAG room thermostat and controls must be connected to their allocated connections. All other types or makes of room thermostats or controls which are used must have a Volt free contact.**

When using an on/off thermostat or control, it is possible that an anticipating resistance must be installed in order to prevent too high temperature fluctuations. As a standard rule this means mercury thermostats. This resistance wire can be ordered by your supplier and must be connected to clamps 23 and 27. The anticipating resistance in the room thermostat has to be set at 0.11 A.

For more detailed questions regarding the components which are not supplied, the country distributor should be contacted.

Connection terminal E-Series																												
230 V~ Power Supply			230 V~						8C44.06.00 External Calorifier connection three-way valve					DHW sensor		Outside sensor ARV12		Bus therm. A B		Room therm. On / Off		24 V~ 100 mA						
N	L		N	L						CH	DHW	N				18	19	20	21	22	23			26	27			
1	2	3								12	13	14	15	16	17													
mains power supply			230 Volts for external control						230 Volts					internal or external three-way valve motor and cylinder sensor					ATAG outside sensor		ATAG room thermostat		On/off thermostat or control (Volt free)		External safety contact		24 Volts maximum 100 mA	

Connection terminal

figure 10

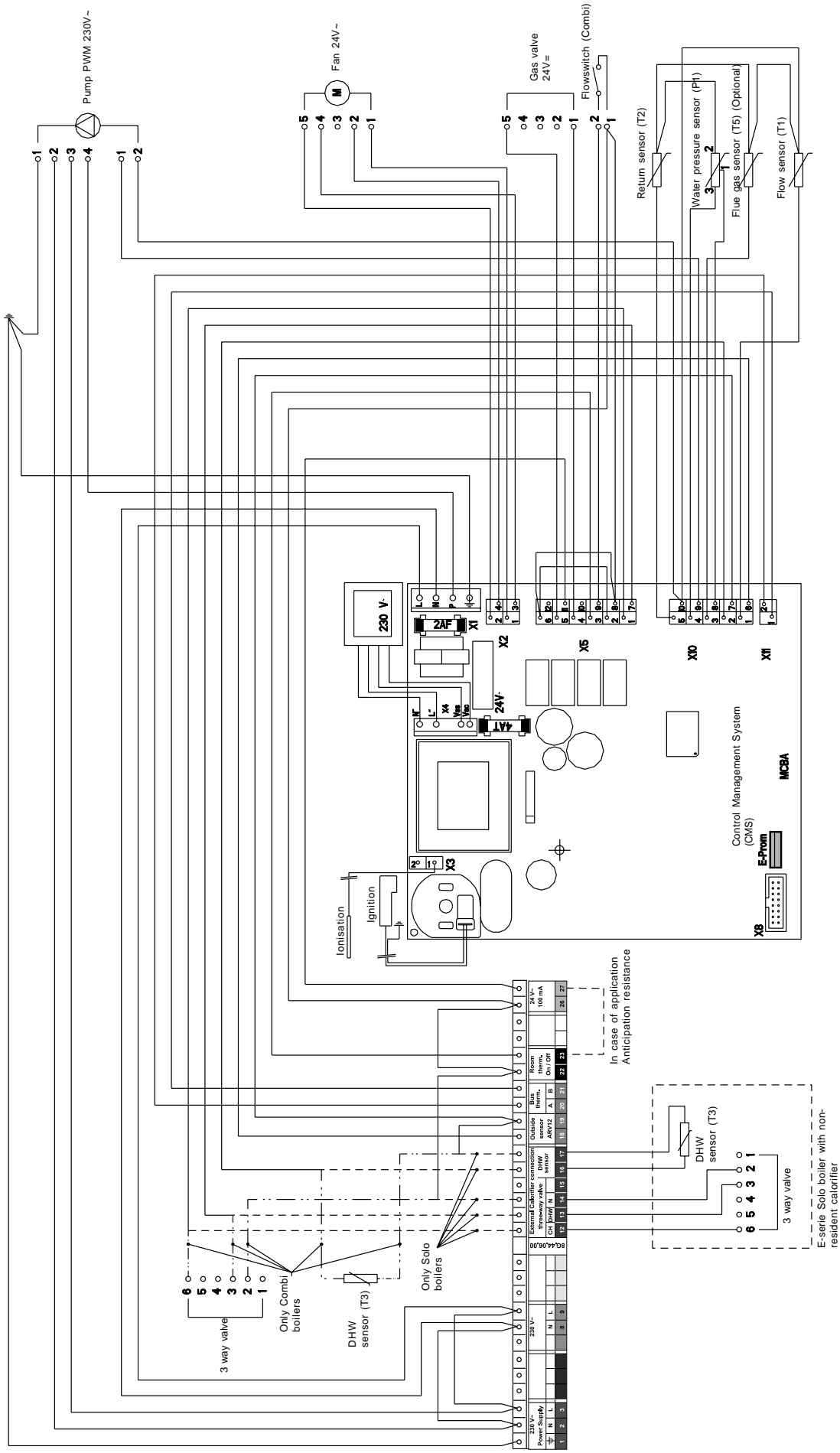

electrical diagram

figure 11

## 9 Boiler controls

The boiler is provided with a fully automatic microprocessor control, called CMS Control Management System. This system simplifies operation by undertaking all major control functions. Initially when power to the boiler is switched on it will remain on standby. There is no indication Led on, until one of the programme keys is pressed. The control panel display will show the relevant state. When the installation is empty the display will show FILL.

The various parameters can be called up in two ways:

### The Good-state or standard read out

The first way shows a simple display read out.

The boiler in operation will always show 'Good'. When a message is necessary this will be shown instead of Good.

### Technical read out





The second way is a technical read out. In normal situations the following will be shown:

- on the left the status in which the boiler is active;
- on the right the flow temperature;
- the water pressure in the installation.

When a message (error or blocking code) is necessary this will be shown instead of the technical read out..



**To switch over from the Good-state to the Technical read out (and vice versa):  
- Press the STEP-key for 5 sec.**

When the system has been filled the automatic venting program starts, when a program has been selected, by pressing the key for Central Heating, DHW or pump program ( , ,  of  ). The program takes 17 minutes and stops automatically. After this the boiler will function normally. (See also 'Filling and venting the boiler and installation).

During this 17 minute program, the boiler will not operate for Central Heating or DHW. The display will show A and the boilers current flow temperature.

On a call for heating or hot water the control system will select the required water control temperature. This water temperature is called the T-set value. On a call for central heating the boiler ignites first at low output. The output is then changed slowly to match the load required. The boiler operates in this way to avoid excessive installation noises and temperature overshoot. On a call for hot water supply the T-set value of central heating return water temperature is monitored. Depending on the amount of sanitary water which is withdrawn from the plate heat exchanger, the central heating return water temperature, from which the input is adjusted, will vary.

## 9.1 Explanation of the function keys



- Central Heating program key.  
Switching the Central Heating on or off (Led on/off);



- Hot Water program key.  
Switching the Domestig Hot Water (DHW) facility on or off (Led on/off);



- PC program key.  
adjusts the pump to continuous water circulation in the central heating system (Led on), or according to the pump overrun times on the relevant programs (Led off);

When the pump is switched on continuously it can lead to undesired heating up of the central heating system during the summer.

- **Mode-key.**  
*After briefly pressing, a selection of the data chapters can be retrieved.  
After pressing for 5 seconds it is possible to enter the code as described in chapter 11.3;*
- **Step-key.**  
*After briefly pressing, the water pressure can be retrieved and pages per chapter can be retrieved.  
After pressing for 5 seconds it switches from the Good-state to technical read out and vice versa;*
- **Reset-key.**  
*After briefly pressing, for:*
  - *unlocking errors;*
  - *ending the access code;**After pressing for 5 seconds an operating stop is made, for example, for activating the automatic venting program.*



Some keys have other functions. These functions are only active when according to the procedure described in chapter 11.3, adjustment has to be changed or data must be retrieved from the CMS.

The other functions are:

- Central Heating program key :      + function;
- Hot Water program key:                - function;
- PC program key :                        store-function, which means that by means of this key a modified setting is confirmed;
- Step-key:                                  scrolling in a data chapter.

## 10 Filling and venting the boiler and installation

The central heating installation needs to be filled with potable water. For filling or topping up the installation you use the filling loop according to the following procedure:

- 1 Switch on the power supply;
- 2 The display will show FILL;
- 3 All functions off (heating, DHW and pump);
- 4 Push briefly the 'STEP'-button: P x.x = water pressure in bar;
- 5 Open the filling loop (Indication on display increases);
- 6 Fill up slowly to 1.5 to 1.7 bar;
- 7 STOP appears on the display;
- 8 Close the filling loop;
- 9 De-aerate the complete installation, start at the lowest point;
- 10 Check the water pressure and if necessary top it up;
- 11 Close the filling loop;
- 12 Activate the functions in use (heating , DHW  and/or pump );
- 13 If A xx appears on the display, wait for 17 minutes;
- 14 Check the water pressure and if necessary top it up to 1,5 to 1,7 bar
- 15 Close the filling loop;
- 16 Press the 'STEP'-button;
- 17 Be sure that the filling loop is closed.
- 18 After the automatic de-aeration program (A xx) is finished the boiler will return to the Good state or Technical read out.

Check the water pressure regularly and top up the installation when necessary. The working pressure of the installation should be between 1.5 and 1.7 bar when the installation is cold.



**It can take a while before all air has disappeared from a filled installation. Especially in the first week noises may be heard which indicate the presence of air. The automatic air vent in the boiler will make this air disappear, which means the water pressure can reduce during this period and therefore topping up with water will have to be done.**

### 10.1 Hot water supply

Apply the water pressure to the DHW(open main valve and/or stop valve of the safety group).

Vent the DHW facility and the hot water installation by opening a hot water tap. Leave the tap open for as long as required until all air has disappeared from the DHW installation and only water is flowing from the tap.

## 11 Commissioning the boiler

Before the boiler is fired, ensure that the boiler and the system are well vented and free of air. Purge the gas line between the gas meter and the boiler and carry out a gas soundness test as specified in the current Gas Safety, Installation & Use Regulations. The boiler does not require adjustment of the burner pressure and air quantity because it is self adjusting and is factory set at the correct value.

### 11.1 Central Heating system

Provided there is a heat requirement from the thermostat or control, the central heating program will be put into operation by means of the  key (central heating program). The circulation pump will start circulating and the boiler will start the burner.

### 11.2 Hot water supply

Provided there is a heat requirement from the cylinder the hot water program will be put into operation by means of the  key (hot water program).



## 11.3 Adjustments

When the boiler is installed it is in principal ready for use. All adjustments of the boiler control are already pre-programmed for a heating system with radiators/convectors with a flow temperature of 85°C. The adjustments are described in the Parameter chapter on page 28.

In certain cases adjustment have to be altered in case of :

- Lowerflowtemperature

Read through the Parameter chapter to adjust the boiler to its installation. Contact ATAG Heating in case of doubt.

Please follow next procudere to alter adjustments:

### Altering adjustments

**STEP 1** Press the Mode-key for 5 secondss.

*The display shows COdE followed by an arbitrary number;*

**STEP 2** Press by means of the + or the - key until the code C123 is shown;

**STEP 3** Press the STORE-key to confirm the code (code blinks1 x).

*Now you have acces to the installer level. There are 4 chapters:*

- PARA Parameters
- I NFO Information chapter (no adjustments possible)
- SERV Service chapter
- ERRO Error-chapter (no adjustments possible)

*The content of the chapters is described on the following pages.*

**STEP 4** Press briefly the MODE-key to select one of the 4 chapters, i.e. PARA;

**STEP 5** Press once or more briefly on the STEP-key to select a Parameter  
*(parameter visible on the left, value on the right) ;*

**STEP 6** Alter the value, if necessary/possible, by means of the + or the - key

**STEP 7** Press briefly on the STORE-key to confirm the alteration.  
*When you have to change more values, repeat from step 5.*

**STEP 8** Press once or more on the MODE-key until StBY or Good is shown:  
*After a few seconds the text StBY will be replaced by the technical read-out or Good-state (Depending from the position the acces code is keyed in)*

When you want to return from an arbitrary position to the original read out press once or more on the MODE-key until StBY is shown.



When during 20 minutes no single key is used the display will return automatically to its original read-out (Good state or technical read out)

Parameter chapter			
PARA	Factory	Description	Range
1	85°C	maximum flow temperature CH	20 - 90°C
2*	01	type of CH installation: <i>radiators; air heating; convectors:</i> <i>T max. flow 85°C; K factor heating line 2.3; gradient 5°C/min; gear differential 6°C</i>	01
		<i>radiators with large surface areas or underfloor heating as additional heating:</i> <i>T max. flow 70°C; K factor heating line 1.8; gradient 5°C/min; gear differential 5°C</i>	02
		<i>under floor heating with radiators as additional heating:</i> <i>T max. flow 60°C; K factor heating line 1.5; gradient 4°C/min; gear differential 4°C</i>	03
		<i>full under floor heating:</i> <i>T max. flow 50°C; K factor heating line 1.0; gradient 3°C/min; gear differential 3°C</i>	04
3	max.	maximum power CH in kW	min-max
4*	00	control principal with on / off thermostat: 100 % on / off thermostat 100 % on / off weather dependant	00 01
5*	2.3	heating line K-factor (see also heating line graph)	0.2 - 3.5
6*	1.4	heating line exponent (see also heating line graph)	1.1 - 1.4
7*	-10	heating line climate zone (see also heating line graph)	-20 - 0
10*	0°C	fine adjustment heating line day temperature	-5 until 5°C
11*	0°C	fine adjustment heating line night temperature	-5 until 5°C
14	7	gradient speed	0 - 15
15*	0	booster after night reduction: no yes	00 01
23	-3°C	frost safety temperature	-20 until 10°C
31	63°C	switch-off temperature of additional cylinder with E boiler	40 - 80°C
36	0	type of three-way valve VC 2010 / VC 8010 / VC 8610 VC 6940 modulating	00 01
43	max.	maximum power DHW in kW	min-max
45	0	Not applicable	00 - 01
89	00	address setting interface: Spare ATAG Bus thermostat (BrainQ, Smart) boiler 1 - 8 in cascade	-01 00 00 - 07

Information chapter		
INFO	Value	Description
1	°C	flow water temperature T1
4	°C	return water temperature T2
5	°C	DHW temperature T3
7	°C	outside temperature T4
8	°C	flue gas temperature T5
16	%	actual power in %
17	kW	actual power in kW
18	kW	actual load in kW
20		indication bus communication
21	GJ	consumption total in GJ (.. x 33 = .. m3)
22	GJ	consumption CH in GJ (.. x 33 = .. m3)
23	GJ	consumption DHW in GJ (.. x 33 = .. m3)
24	hour	total number of burner run hours
25	hour	number of burner run hours CH
26	hour	number of burner run hours DHW
32	hour	total number of hours counter
37	hour	total number of run hours pump CH and DHW
46	hour	within how many hours is service required

Service chapter			
SERV	Value	Description	Range
1	OFF	boiler in operation with burner function on	OFF - max.
2	OFF	fan adjustable and burner off	OFF - max.
3	OFF	pump adjustable with burner on	OFF - max.
4	OFF	showroom position ON = active and OFF = non active	ON - OFF

Error chapter			
ERRO	Value	Description	
Err.L - Err.5		Last saved error until 5 last predecesing errors	
1		error code	
2		operation status boiler	
3	°C	flow water temperature T1	
4	°C	return water temperature T2	
5	kW	load	
6	%	pump capacity	

Parameter-, Info-, Service- and Error-chapters

Table 6

\* Most of the data in this table can be requested by the BrainQ. Most of the adjustments which are stated in this table are unnecessary when in combination with the ATAG BrainQ thermostat and will be taken care of by the BrainQ itself and do not have to be adjusted. For further information regarding to the BrainQ thermostat, please refer to the ATAG BrainQ installation manual.

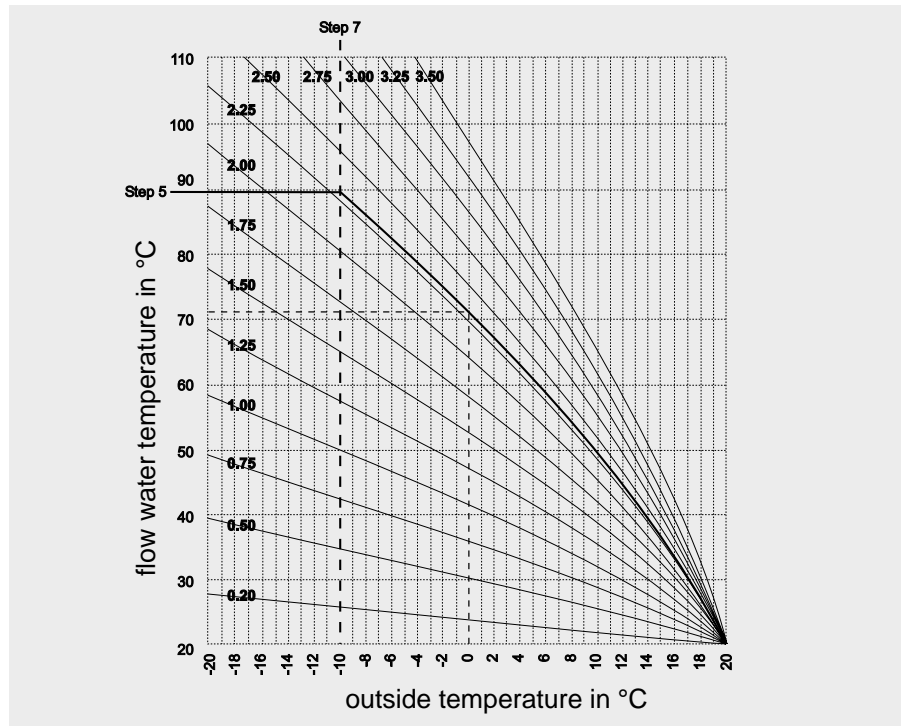

heating line adjustments Parameter Step 6 and 7

graph 2



## 11.4 Activating factory settings (green key function)

To activate the factory settings again please follow the next procedure (Note: all altered adjustments will be set back):

- Select, when necessary, the technical read out;
- Select with the MODE-key chapter PARA;
- Press the STORE-key.

The word "Copy" will appear and the factory settings are active again.

## 12 Isolating the boiler

In some situations it may be that the entire boiler must be switched off. By switching off the three keys with the lamps for central heating, hot water and pump program ( ,  or  ), the boiler is switched off. Leave the plug in the wall socket, which means the circulation pump and the three-way valve are activated once every 24 hours in order to prevent jamming.



**In the event of frost danger it is advisable to drain the boiler and/or the installation.**

## 13 Commissioning



**Work on the boiler must be carried out by a competent person, (Ref: Gas Safety, Installation & Use Regulations )** using correctly calibrated instruments with current test certification.

To commission the boiler the casing has to be removed. Remove the lower part of the casing which covers the expansion vessel (if present) forward. The casing is fixed by 4 quick release clamps and 5 screws (4x 1 clamp and 1 behind door). After removing the screws, unlock the clamps, now the casing can be removed forward.

The boiler settings, such as burner pressure and adjustment of the air quantity are unnecessary, due to the fact that the boiler operates with a so-called zero pressure control. This means the correct gas quantity is controlled by the suction operation of the fan. The fine adjustment which is carried out at the factory is one off, which means that adjusting of these values is unnecessary. Only when replacing the gas valve, venturi and/or the fan, does the zero pressure and the incorrect CO<sub>2</sub> adjustment have to be checked and, if necessary, adjusted to the correct value.



**Always check the installation of all parts through which gas flows (using leak-search spray)**

### 13.1 Checking for contamination

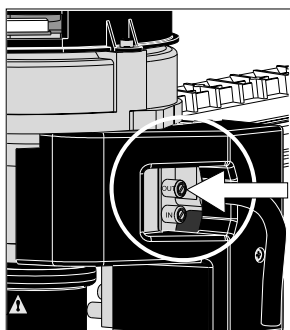

Check point contamination  
figure 12

In order to be able to check the boiler for contamination in the following running years it is advisable to measure the maximum air displacement in the boiler when putting the boiler into operation. This value can be different with each type of boiler.

In order to be able to measure this value follow the next procedure:

- Press the Central Heating and DHW buttons once to ensure that the boiler is OFF and not firing.
- Press the MODE-key for 5 seconds.
- The display will show COdE followed by an arbitrary number;
- Select by means of the + or the - key the code C123;
- Press the Store-key to confirm the code (code blinks 1 x);
- Press the MODE-key until SERV is shown;

- Press the STEP-key until 2 is shown; alternately 2 and OFF will be shown.
- Undo the upper measuring nipple on the gas valve open (fig. 12);
- Connect the hose of the digital pressure gauge to the upper measuring nipple of the gas valve
- Press the + key until the maximum value is achieved; The fan will function to its maximum revolutions (burner stays off)
- Measure the under pressure and write down this value. At the next commissioning visit this value may drop 20% of its original value on the moment of installation. When this value is dropped more than 20% the boiler needs maintenance.
- Press the - key until OFF is shown (keep key pressed) With this the procedure is finished.

## 13.2 Checking of the zero pressure control



The zero pressure control is set at the factory. To measure this value you need a difference pressure gauge with a range of +0,2 to -0,8 mbar. Follow the next procedure:

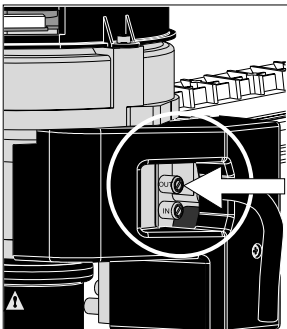

Check point contamination  
figure 13

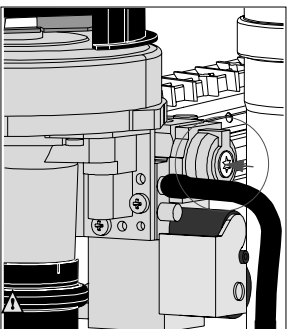

Adjustment zero pressure  
figure 14

- Turn the boiler on so that the boiler is alight.
- Press the MODE-key for 5 seconds.
- The display will show COdE followed by an arbitrary number;
- Select by means of the + or the - key the code C123;
- Press the Store-key to confirm the code (code blinks 1 x);
- Press the MODE-key until SERV is shown;
- Press the STEP-key once until 1 is shown; alternately 1 and OFF will be shown.
- Undo the upper measuring nipple on the gas valve open (fig. 13);
- Connect the hose of the digital pressure gauge to the upper measuring nipple of the gas valve
- Press the - key until the minimum value is achieved; The fan will function to its minimum revolutions (burner is active)
- Measure the negative pressure. Value should be +/- 0 to -4Pa (+/- 0 to -0,04 mbar).
- If the zero pressure deviates too much:
  - Remove black cover of the gas valve
  - Remove cap with Torx key (fig. 14)
  - Turn slightly the Torx screw behind the cap:
    - Turn left is positive pressure deviation
    - Turn right is negative pressure deviation
- Ending this procedure is done by pressing the Reset key.
- Proceed by checking the CO2 value and correct it if necessary.

## 13.3 Checking the CO<sub>2</sub>



The CO<sub>2</sub> percentage is factory-set. This has to be checked at commissioning, maintenance and faults.

This can be checked by means of the following procedure:

- Remove the black cover of the gas valve by unscrewing the sealed screw.
- Put the boiler into operation and take care that it can deliver its heat;



Tip: If there is no demand for heat on CH, turn the hot water tap completely open and measure the CO<sub>2</sub>.

- Press the MODE-key for 5 seconds.
  - The display will show COdE followed by an arbitrary number;
  - Select by means of the + or the - key the code C123;
  - Press the Store-key to confirm the code (code blinks 1 x);
  - Press the MODE-key until SERV is shown;
  - Press the STEP-key once until 1 is shown; alternately 1 and OFF will be shown.
  - Calibrate the CO<sub>2</sub> meter ;
  - Place the lance of the CO<sub>2</sub> meter into the check point (see fig. 15);
  - Press the + key until the maximum value (in kW) is achieved;  
The boiler will burn on full load (value on display in kW)
  - Check Table 7 for the correct CO<sub>2</sub> percentage (page 33)
  - Let the CO<sub>2</sub> meter do its measuring procedure.
  - Adjust, if necessary, the adjustment screw to correct the CO<sub>2</sub> value (see fig. 16).
- Ending the CO<sub>2</sub> measuring procedure:
- Press the - key until OFF is shown (keep key pressed).  
With this the procedure has ended..
  - Replace the black cover on the gas valve and fix it with the screw.

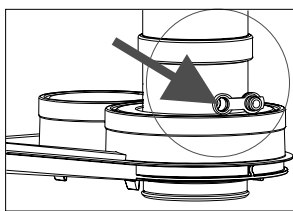

checkpoint CO<sub>2</sub>

figure 15

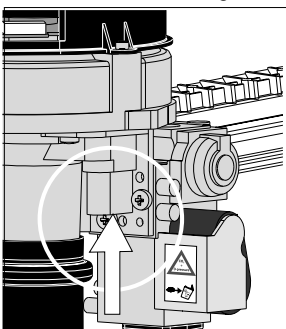

adjustment screw CO<sub>2</sub>  
figure 16

## 14 Maintenance

Maintenance or changes to the boiler may only be carried out by an authorised technician.

### 14.1 The frequency of maintenance

We advise that an inspection is carried out every year with an overhaul every three years. When doing this the circumstances of the boiler's location must be taken into account. From this one can determine whether to deviate from this advice.

**Please contact the country distributor for further guidance on the frequency and service requirements.**

### 14.2 Maintenance activities

To carry out the maintenance activities please follow the next procedure:

- switch off the power supply;
- remove the four screws out of the quick release fasteners;
- remove the screw behind the door on the front of the casing;
- remove the casing towards the front.

#### The air box

- the casing is also the airbox
- clean the casing with a cloth with a simple (non-abrasive) cleaning agent;

#### The fan unit and burner cassette

- remove the electrical connection plug from the gas valve and fan motor;
- loosen the nut of the gas pipe under the gas valve;
- replace the gasket with a new one;
- loosen the front cross head screw of the black plastic silencer;
- after this turn the two clamping rods  $\frac{1}{4}$  turn and remove them by pulling them forward. Note the right turning direction (red indicator);
- slightly lift the fan unit and remove it towards the front of the heat exchanger;
- remove the burner cassette out of the fan unit;
- check the burner cassette for wear, pollution and possible cracks. Clean the burner cassette with a soft brush and vacuum cleaner. If burners are cracked replace the complete burner cassette;
- replace the gaskets between burner and fan unit and the gasket between fan unit and heat exchanger;
- check the venturi and the gas-air distribution plate for pollution and clean this part, if necessary with a soft brush and vacuum cleaner. If the air box contains a lot of dirt it is plausible that the fan itself is dirty as well. To clean this, the fan has to be removed from the hood and the venturi. Clean the fan with a soft brush and a vacuum cleaner. Replace the gasket and ensure that all gaskets of the fan parts are mounted correctly.

#### Heat exchanger

- check the heat exchanger for contamination. Clean this if necessary with a soft brush and a vacuum cleaner. Prevent dirt falling down into the heat exchanger.

**Flushing the heat exchanger from the top down is not permitted**

Refitting of the components is done in reverse order.

**Make sure that during refitting the clamping rods they are put in the right position. They should be turned vertical.**

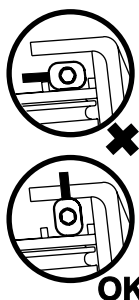

Ignition electrode

The replacement of the electrode is only necessary when the electrode is worn off. This can be checked by measuring the ionisation current. The minimum ionisation current has to be higher the 4µA on full load.

If the viewing glass is damaged the complete electrode must be replaced.

Replacement goes as follows:

- remove the electrical connections of the electrode;
- press the clips on both sides of the electrode to both sides and remove the complete electrode;
- remove and replace the gasket;

Refitting of the components is done in reverse order.

Siphon and condensate tray

- first remove the condensate cup;
  - Check this for pollution. If there is no sign of strong pollution it is not necessary to clean the condensate tray. If there is a strong pollution in the cup it is necessary to remove and clean the condensate tray;
- check the O-rings of the cup as well as those from the pipe and replace if necessary;
- clean both part by flushing it with clean water;
- grease the O-rings again with acid free O-ring grease to make fitting easier;
- if there is a leak at the siphon cup or tray the complete siphon unit has to be replaced by S4421200;
- remove the plug from the flue gas sensor if present;
- turn the two short clamping rods ¼ turn and remove them by pulling them forward; Note the right turning direction (red indicator);
- lift the flue gas pipe out of the condensate tray;
- press the condensate tray carefully downwards and remove it by pulling it forward;
- replace the gasket between condensate tray and heat exchanger by a new one;
- clean the condensate tray with water and a hard brush;
- check the condensate tray for leaks.

Refitting is done in reverse order.

Note that the gasket of the condensate tray seals completely.

**Make sure that during refitting of the clamping rods they are put in the right position. They should be turned vertically.**

**Always replace all removed gaskets of dismantled parts during the maintenance activities.**

Put the boiler into operation and check the CO<sub>2</sub> (see page 30).

**Replace the secure screws A, B, C, D and E in the quick-release fasteners after the maintenance activities.**

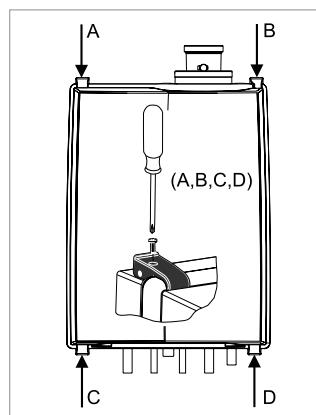
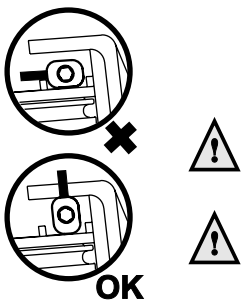

vergrendeling mantel

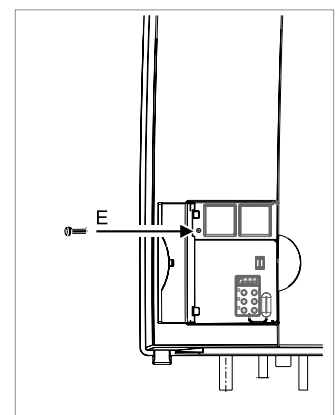

figuur 13

**14.3 Warranty**

For warranty conditions we refer to the warranty card supplied with the boiler.



## 15 Technical specifications

Boiler type		ATAG E-Series			
		Combi		Solo	
		E22C	E32C	E22S	E32S
Input Hs CH	kW	22	32	22	32
Q <sub>n</sub> Output Hi CH	kW	19,8	28,8	19,8	28,8
Q <sub>nw</sub> Input Hs DHW		25	38		
Efficiency class according BED		★★★★	★★★★	★★★★	★★★★
Efficiency according EN677 (36/30°C part load, Hi)	%	109,7	109,9	109,7	109,9
Efficiency according EN677 (80/60°C full load, Hi)	%	97,6	97,9	97,6	97,9
Modulation range CH (capacity 80/60°C)	kW	4,4 - 19,3	6.1 - 28,2	4,4 - 19,3	6.1 - 28,2
Modulation range CH (capacity 50/30°C)	kW	4,9 - 21,0	6.8 - 30,6	4,9 - 21,0	6.8 - 30,6
Nox class EN483				5	
CO <sub>2</sub>	%			9	
Temperature class for PP flue				T100	
Appliance type			C13 C43 C53 C63 C83		
Flue gas temp. CH (80/60°C on full load)	°C			68	
Flue gas temp. CH (50/30°C on low load)	°C			31	
Categories				II2L3P	
Gas consumption G20 CH (DHW) (at 1013 mbar/15°C)	m <sup>3</sup> /h	2,10 (2,38)	3,05 (3,62)	2,10	3,05
Electr. power consumption max.	W			145	
Electr. power consumption stand by	W			10	
Current	V/Hz			230/50	
Fuse rating	A			5	
Degree of protection acc. EN 60529				IPX4D	
Weight (empty)	kg	39	40	37	40
Width	mm			500	
Height	mm			650	
Depth	mm			395	
Water content CH	l	3,5	5	3,5	5
Water content DHW	l	0,5	0,7		
After run time pump CH	min			15	
After run time pump DHW	min	1	1		
P <sub>MS</sub> Water pressure min./max.	bar			1/3	
P <sub>MW</sub> Water pressure DHW max.	bar		8		
Flow temperature max.	°C			85	
Pump type		UPS20-50	UP20-60	UPS20-50	UP20-60
Available pump height CH	kPa	28	17	27	15
Label				Sedbuk A rate	
DHW flow (at 38°C)	l/min	10,7	17,5		
DHW flow (at 35°C ΔT)	l/min	8,6	14,0		
DHW temperature (T <sub>in</sub> =10°C)	°C	60	60		
Minimum flow rate	l/min	<2,0	<2,0		
Content expansion vessel	l	8	12	8	12
Pre-charge pressure expansion vessel	bar	1	1	1	1
CE product identification number(PIN)				0063BR3405	

## 16 Parts of the boiler

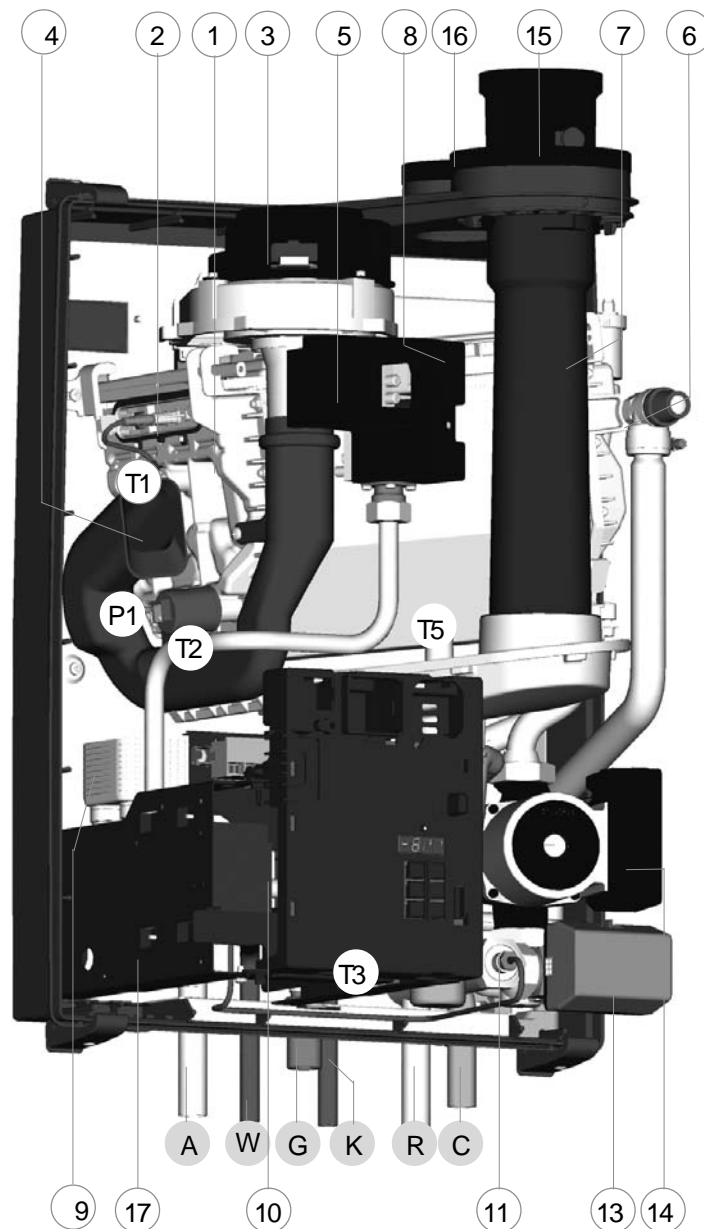

ATAG E

figure 15

- |                      |                                    |                          |
|----------------------|------------------------------------|--------------------------|
| 1 heat exchanger     | 8 ceramic burner cassette          | 15 flue gas duct         |
| 2 ignition unit      | 9 plate heat exchanger DHW (Combi) | 16 combustion air supply |
| 3 fan unit           | 10 operating panel                 | 17 type plate            |
| 4 air inlet damper   | 11 Control Tower (CMS)             |                          |
| 5 gas valve          | 12 water filter return CH          |                          |
| 6 safety valve       | 13 three-way valve                 |                          |
| 7 automatic air vent | 14 circulation pump                |                          |

T1 flow sensor  
 T2 return sensor  
 T3 sensor DHW (combi)  
 and flow switch

P1 water pressure sensor

G gas pipe  
 A flow connection central heating  
 R return connection central heating  
 C condensate pipe  
 K cold water pipe (combi)  
 W hot water pipe (combi)

## 17 Installation examples

### 17.1 Radiator installation with thermostatic radiator valves

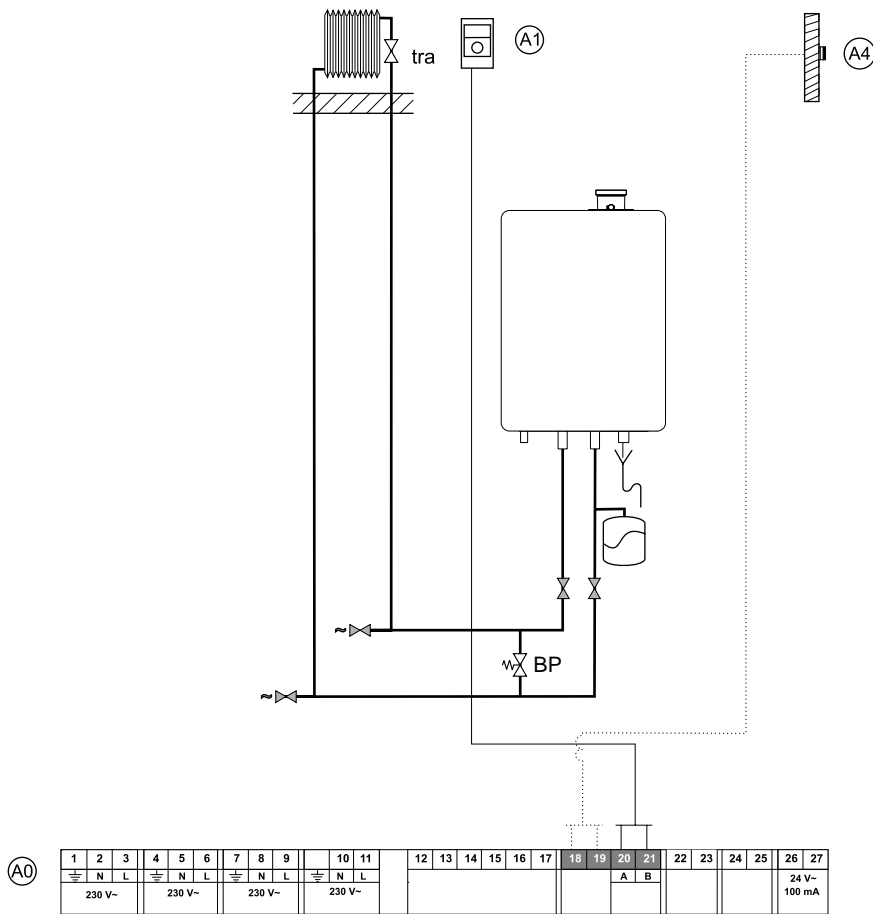

installation example

figure 16

#### A Boiler:

- A0 Connection terminal ATAG E  
 A1 ATAG BrainQ thermostat RSC  
 A4 Outside sensor ARV12

tra Thermostatic radiator valve  
 BP Automatic by-pass



Always use a by-pass in combination with thermostatic radiator valves.

## 17.2 Radiator installation with underfloor heating zone

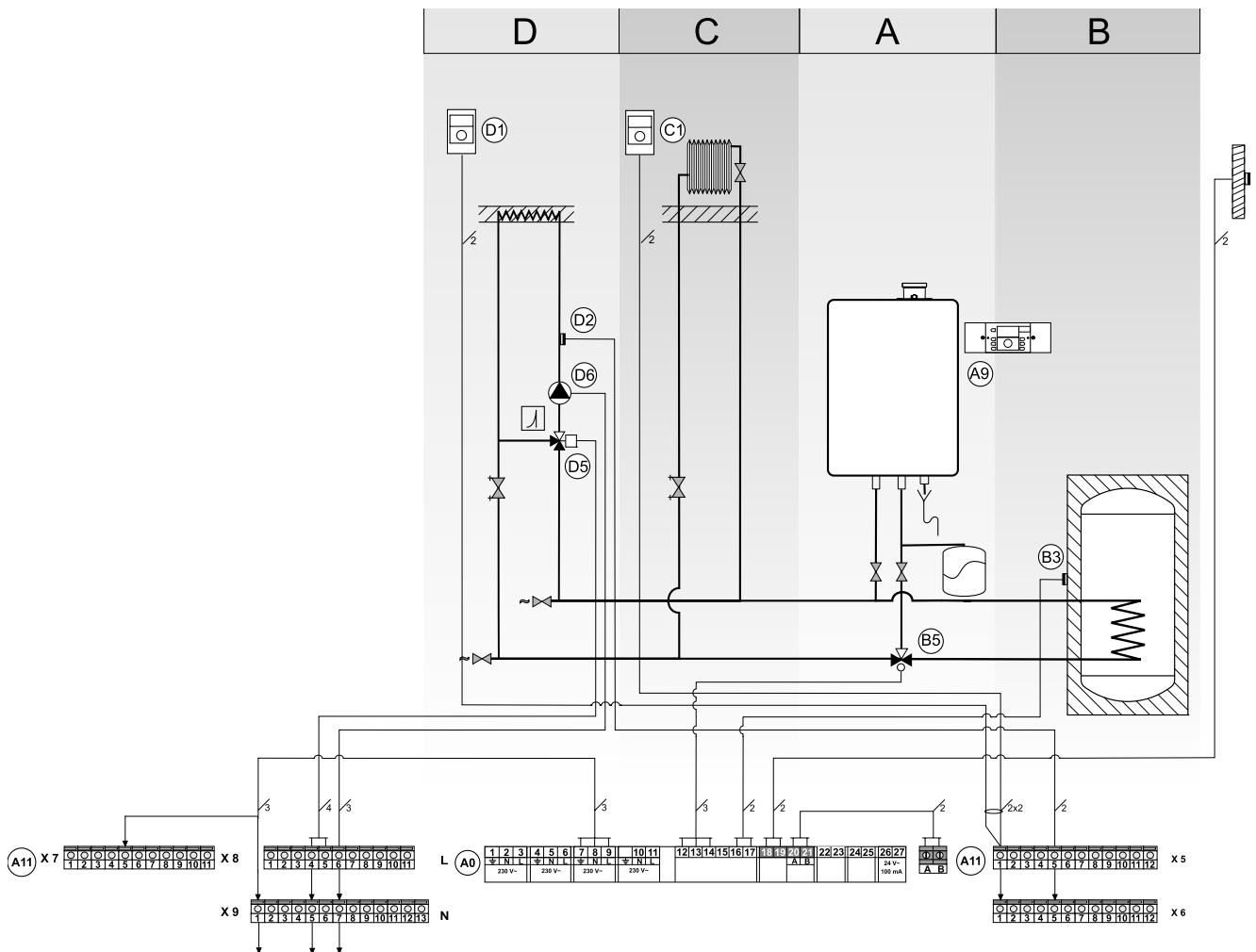

installation example

figure 17

- A Boiler:**
- A0 Connection terminal ATAG E
  - A4 Outside sensor ARV12
  - A9 ATAG MadQ zone controller 23BC
  - A11 Connection terminal MadQ wall mounted
- B Cylinder:**
- B3 Cylinder sensor
  - B5 Three-way valve cylinder
- C Direct zone:**
- C6 Pump direct zone
- D Mixing zone:**
- D2 Flow sensor mixing zone
  - D5 Three way valve mixing zone 230V~
  - D6 Pump mixing zone

See also the installation manual ATAG MadQ Zone controller.

## 18 Error indication

A detected error is indicated on the display by means of a blocking or error messages. A distinction should be made between these two messages due to the fact that blocking can be of a temporary nature, however, error messages are fixed lockings. The control will try its utmost to prevent locking and will temporarily switch off the boiler by blocking it. Below is a list of some of the messages.

Blocks **bL** with a number in the last 2 positions.

- bL60** Block 60:  
Incorrect parameter setting of the minimum or maximum power.
- bL67** Block 67:  
A  $\Delta T$  has been detected between flow and return sensor whereas the burner is not in operation. After the  $\Delta T$  has disappeared the block will disappear.
- bL80** Block 80:  
Maximum flue gas temperature has been exceeded (if present). The block will not be cancelled until the flue gas temperature has lowered to a correct figure.
- bL81** Block 81:  
The flue gas sensor is not connected although it was connected to the control. The burner is blocked until the flue gas sensor is reconnected.
- bL82** Block 82:  
The flue gas sensor has short-circuited, heat requirement blocked and pump capacity at minimum.
- bL85** Block 85:  
The control has not detected a water flow. The venting cycle is started. If during this cycle water flow is detected, the venting cycle is ended and the burner is released.
- bL86** Block 86:  
The frequency of the power supply deviates more than 2,5Hz (<47,5Hz, >52,5Hz)

Error **E** with a number in the last two positions.

- E 00** Error 00: Poorflame-forming
- E 01** Error 01: short-circuit of 24 volt circuit
- E 02** Error 02: no flame-forming
- E 04** Error 04: the control unit has detected an error
- E 05** Error 05: fault control unit
- E 12** Error 12: fuse 24 volt/3AT faulty
- E 19** Error 19: fault control
- E 28** Error 28: number of revolutions not reported back from fan

## 19 CE Declaration of conformity

### CE DECLARATION OF CONFORMITY

Hereby declares ATAG Verwarming Nederland BV that,

the condensing boiler types: ATAG

E22S E22C  
E32S E32C

are in conformity with the provisions of the following EC Directives, including all amendments, and with national legislation implementing these directives:

<u>Directive</u>		<u>Used standards</u>
Gas Appliance Directive	90/396/EEC	EN483: 1999 EN50165: 1997
Efficiency Directive	92/42/EEC	EN677: 1998
Low Voltage Directive	73/23/EEC	EN50165: 1997 EN60335-1: 1994
EMC Directive	89/336/EEC	EN61000-3-2: 2000 EN61000-3-3: 1995 EN61000-6-1: 2001 EN61000-6-3: 2001

Report numbers

	GAD	ED	LVD	EMC D
ATAG E	177405	177405	177405	06C00165

and that the products are in conformity with EC type-examination certificate number E0430, as stated by KIWA-Gastec Certification BV, Apeldoorn, The Netherlands.

Date : 1 May 2006

Signature :



Full name : P. Kalverboer  
CEO

**ATAG**  
**Verwarming**

Adres: Galileïstraat 27, 7131 PE Lichtenvoorde • Postadres: Postbus 105, 7130 AC Lichtenvoorde  
Telefoon: +31(0) 544 391777, Fax: +31(0) 544 391703  
E-mail: info@atagverwarming.com Internet: http://www.atagverwarming.nl

Certificate



**UK APPROVAL**  
**Certificate Number: 0401702**

Date Issued: 31<sup>st</sup> March 2006  
Date Expired: 22<sup>nd</sup> January 2009

**Description: ATAG E Range of wall mounted  
combination condensing boilers**

**Product Designation: ATAG E Range 18-32Kw**

This is to certify that the above range of products manufactured / supplied by

**ATAG Verwarming Nederland BV**

has been tested and found to comply with the requirements of the Water Supply (Water Fittings) Regulations 1999 for England and Wales, the Water Byelaws 2000, Scotland and the Water Regulations Northern Ireland.

This certificate must be read in conjunction with the acceptance letter for this product.

*This approval is intended for compliance with the above Regulations and must not be considered equivalent to the product certification provided by Kiwa N.V*

To comply with the Regulations and Byelaws all products require the correct installation. Details of the installation requirements (IRN's) can be obtained from the acceptance letter supplied with this certificate.  
Applicable IRN's for this certificate – R001, R140, R360

Authorised Signature  
Kiwa Quality Services Ltd

Kiwa Quality Services Ltd  
The Innovation Centre  
Victoria Park  
Festival Drive  
Ebbw Vale  
Gwent  
NP23 8XA  
UNITED KINGDOM  
Tel: 0044 (0) 1495 356795  
Fax: 0044 (0) 1495 350020  
E-mail: info@kiwa.co.uk  
Web: www.kiwa.co.uk

Certificate Issued To –  
ATAG Verwarming Nederland BV  
Galileistraat 27  
7131 PE  
Lichtenvoorde  
The Netherlands

Tel: 0031 544 391 777  
Fax: 0031 544 391 703





**kiwa**  
approved  
product



UK WATER SUPPLY  
REGULATIONS



**Ditributor for UK**

ATAG Heating UK Ltd. • Unit 3 • Beaver Trade Park • Quarry Lane Chichester West Sussex PO19 8NY  
Phone: 01243 815 770 • Fax 01243 839 596 • E-mail: [info@atagheating.co.uk](mailto:info@atagheating.co.uk) • Internet: [www.atagheating.co.uk](http://www.atagheating.co.uk)

**Ditributor for Ireland**

Total Energy Management Ltd. • Unit 9 • Ballybritt Industrial Estate • Monivea Road Galway Ireland  
Phone: 091 769174 • Fax 091 769485 • E-mail: [info@tem.ie](mailto:info@tem.ie) • Internet: [www.tem.ie](http://www.tem.ie)

This renewed publication cancels all previous installation instructions. The company reserves the right to change the specifications and dimensions without prior notice.