

Installation & Servicing Instructions

A200S A203C
A320S A325C
 A325ECX



Boiler	G.C No
A200S	41-310-14
A320S	41-310-17
A203C	47-310-15
A325C	47-310-17
A325ECX	47-310-18

CE PIN 0063BT3195

These instructions to be retained by user.



8G.51.59.05/08.11 Changes reserved.

Explanation of the control panel and keys

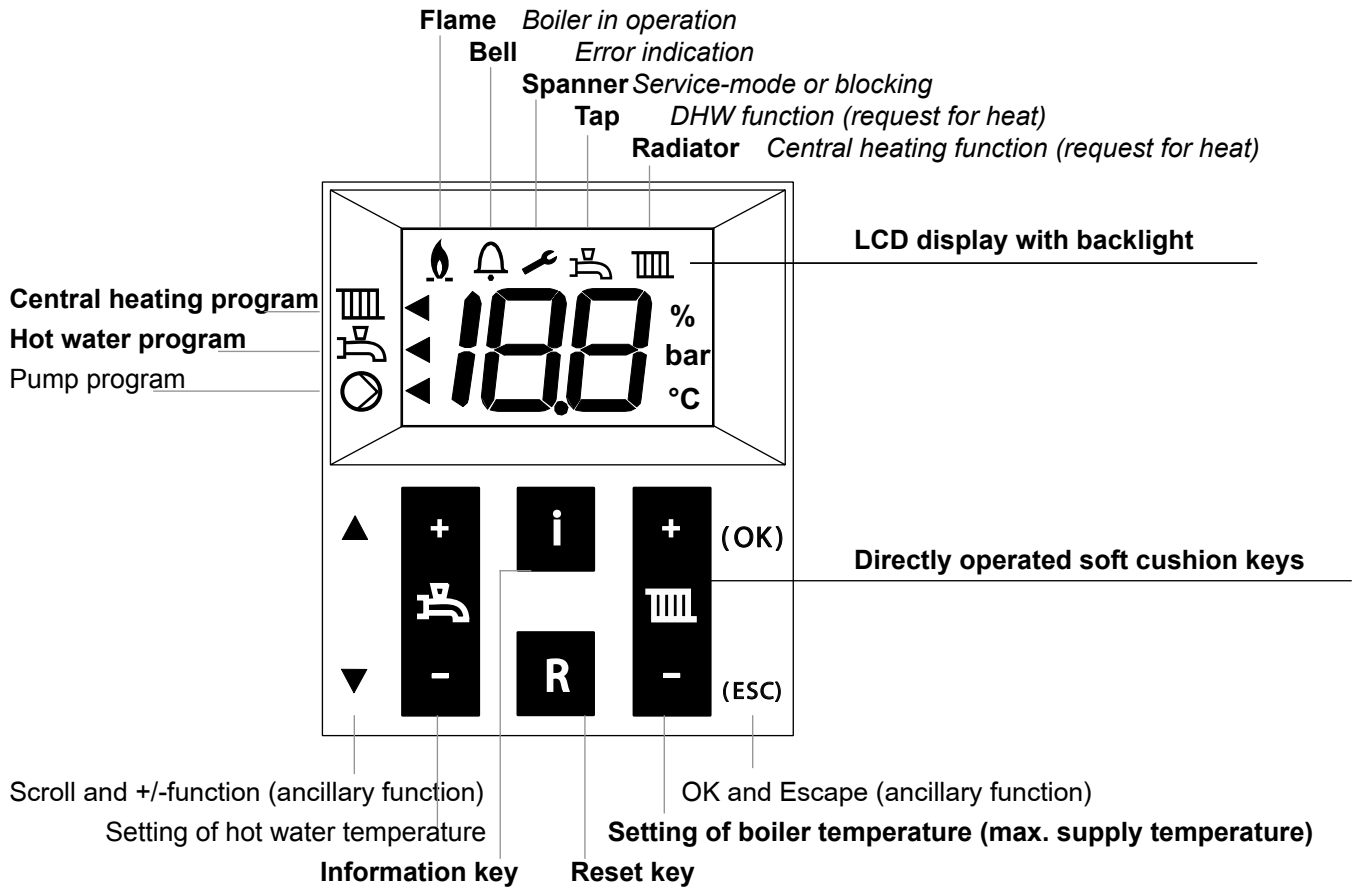

Information on the water pressure:

The default view of the display shows the water pressure (bar) in the CH unit.

If the water pressure gets (too) low it is indicated as follows:

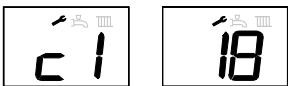

Water pressure is too low (<1.0 bar).
 Bell symbol visible and c1 18.
 Power is reduced by 20%.
 The installation should be refilled.

Press the i-key until A6.

or

The actual water pressure will be shown



Water pressure is too low (<0.7 bar).
 Bell symbol visible and c1 18.
 The boiler is taken out of operation.
 The installation should be refilled.

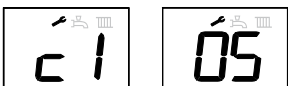

After the installation has been refilled and if the pressure was below 0.7 bar the de-aeration program will start. This will last for approx 7 mins.



If the water pressure is too high, it will be displayed as follows:

Water pressure is too high (> 3.0 bar).
 Bell symbol visible and c1 17.
 The boiler is taken out of operation.
 The installation pressure should be reduced
 by draining water from the heating system.

Contents

1	Introduction	4
2	Rules	4
3	Delivery package.....	6
4	Boiler description.....	6
5	Mounting the boiler.....	7
5.1	Dimensions	8
6	Connecting the boiler	9
6.1	Central heating system	9
6.2	Expansion vessel	11
6.3	Heating systems with plastic pipes	12
6.4	Gas connection	12
6.5	Hot water supply (DHW Combi boilers)	13
6.6	Condensation drain pipe	14
6.7	Flue gas exhaust system and air supply system	16
6.7.1	Dimensioning of the flue gas and air intake duct	20
7	External hot water cylinders (Solo boilers).....	21
8	Electrical connection	21
8.1	Room thermostat	22
8.2	Electrical diagram Solo boiler	23
8.3	Electrical diagram Combi boiler	24
9	Filling and bleeding of boiler and CH installation	25
9.1	Hot water supply	25
10	Boiler controls	26
9.1	Controls and explanation of the functions.....	27
11	Commissioning the boiler.....	28
11.1	Hot water supply	28
11.2	CH system	28
11.3	Pump function	28
11.4	Settings	29
11.5	Activating the factory setting (green key function)	31
12	Isolating the boiler	32
13	Commissioning.....	32
13.1	Checking the O ₂	33
13.3	Maintenance activities.....	34
13.3	Maintenance frequency.....	36
13.4	Warranty.....	36
14	Error message	36
15	Technical specifications.....	37
16	Parts of the boiler	38
17	Declaration of Conformity.....	39
18	Kiwa certificate	40
	Benchmark Checklist	41
	Service Record.....	42



Work on the installation should only be carried out by qualified personnel with calibrated equipment.



1 Introduction

These instructions describe the functioning, installation, use and primary maintenance of ATAG central heating boilers for the United Kingdom and Ireland. Where necessary the different regulations for each country are separately described.

These instructions are intended for the use of Gas Safe registered installers or registered Bord Gais installers in connection with the installation and putting into operation of ATAG boilers. It is advisable to read these instructions thoroughly, well in advance of installation. Separate instructions for use are supplied with the boiler for users of ATAG central heating boilers. ATAG is not liable for the consequences of mistakes or shortcomings which have found their way into the installation instructions or user's manual. Further, ATAG reserves the right to alter its products without prior notification.



When delivering the boiler, give the customer clear instructions concerning its use; present the customer with the user's manual and card.

Each boiler is fitted with an identification plate. Consult the details on this plate to verify whether the boiler is compliant with its intended location, e.g.: gas type, power source and exhaust classification.

On completion of the installation the installer or commissioning engineer must fill out and complete the Benchmark Commissioning Checklist found on page 41 of this manual and hand this to the customer for future record keeping. The Benchmark Service Record must also be completed by the service agent following each service call, and return to the customer. A copy of the Benchmark Commissioning Checklist must be returned to ATAG Heating along with the warranty registration card to register the appliance for the standard warranty benefits.

Relevant Installation, Service and User manuals:

- ATAG Monopass
- Flue system guide

2 Rules

The following regulations apply to installation of ATAG central heating boilers:

Legislation and Regulations.

Gas Safety (Installation and Use). All gas appliances must by law, be installed by a competent person, eg. Members of Gas Safe Register and in accordance with the current Gas Safety Regulation. Failure to install appliance correctly could lead to prosecution.

All Gas Safe registered installers carry a Gas Safe ID card and have a registration number. You can call Gas Safe Register directly on 0800 408 5577.

In addition to the above regulations this appliance must be installed in compliance with the current IEE Regulations, the Building Standards (Scotland Consolidation) Regulations. Regulations and bye laws of the Local Water Authority and the Current Health and Safety Regulation.

The Benchmark Scheme

Benchmark places responsibilities on both manufacturers and installers. The purpose is to ensure that customers are provided with the correct equipment for their needs, that it is installed, commissioned and serviced in accordance with the manufacturer's instructions by competent persons and that it meets the requirements of the appropriate Building Regulations. The Benchmark Checklist can be used to demonstrate compliance with Building Regulations and should be provided to the customer for future reference.



Installers are required to carry out installation, commissioning and servicing work in accordance with the Benchmark Code of Practice which is available from the Heating and Hotwater Industry Council who manage and promote the Scheme. Visit www.centralheating.co.uk for more information.

Ireland:

- Irish standard 813
- Domestic gas installations

The current Electricity at Work Regulation must be complied with and also be in accordance with the relevant and current editions of the British Standards.

The ATAG A boiler is a certified appliance and must not be modified or installed in any way contrary to this Installation Manual. Manufacturers instructions must not be taken, in any way, as overriding statutory obligations.

The ATAG A is a central heating boiler with an optional integrated hot water function. These boilers must be connected according to these instructions and all installation norms in respect of the part of the boiler to be connected.

Observe the following rules of safety:

- All work on the boiler must take place in a dry environment.
- ATAG boilers may never be in operation without their housing, except in connection with maintenance or adjustments (see Chapter 13 and 14).
- Never allow electrical or electronic components to come into contact with water.

Carry out the following tasks in connection with maintenance, etc. to an already-installed boiler:

- Shut down all programs
- Close the gas tap
- Remove the plug from the wall socket
- Close the stop cock of the boiler's intake connection

Take note of the following when maintenance or adjustments are needed:

- The boiler must be able to function during these activities; for this reason, the boiler's supply voltage, gas pressure and water pressure must be maintained. Ensure that there is not a source of potential danger during these activities.



Following maintenance or other activities; always check the installation of all parts through which gas flows (using leak-search spray).

The following (safety) symbols may be encountered in these installation instructions and on the boiler:



This symbol indicates that the boiler must be stored away from frost.



This symbol indicates that the packaging and/or contents can be damaged as a result of insufficient care taken during transport.



This symbol indicates that, whilst still in its packaging, the boiler must be protected from weather conditions during transport and storage.



KEY-symbol. This symbol indicates that assembly or dismantling, must be carried out.



ATTENTION symbol. This symbol indicates that extra attention must be paid in connection with a particular operation.



Useful tip or advice

3 Delivery package

The boiler is delivered ready for use. The delivery package is composed as follows:

- Boiler with cover;
- Automatic air vent (in boiler);
- Safety valve 3 bar
- Three way valve (in boiler, only Combi);
- Expansion vessel 8liter / 0,8 bar or 12liter / 1 bar (in boiler);
- Dosing valve;
- Commissioning valves with drainpoint (CH 2x, 1x DHW cold)
- Gas isolating valve;
- Flue non return valve (pre-assembled in boiler)
- Suspension bracket;
- Fittings consisting of plugs and screws;
- Drawing template;
- Installation instruction;
- User manual;
- Warranty Card and Benchmark logbook.

The ATAG A is mainly equipped with 230V electrical components.

The following components are not present in the boiler as a standard and should be included in the installation according to the requirements (supplied by third parties):

- Filling loop;
- Automatic by-pass;
- External controls.

4 Boiler description

Room sealed boiler

The boiler retrieves its combustion air from the outside then discharges the flue gasses to the outside.

Condensing

Retrieves heat from the flue gasses. Water condensates on the heat exchanger.

Modulating

Higher or lower burning according to the heat demand.

Stainless Steel

Super solid kind of steel which keeps its quality for life. It will not rust or erode in contrast to composition materials, like aluminium.

The ATAG A is a room sealed, condensing and modulating CH boiler equipped with an integrated hot water supply.

The boiler is equipped with a compact stainless steel heat exchanger with smooth pipes. It is a well thought-out principle using sustainable materials.

The boiler burns (natural) gas to supply heat. This heat is transferred in the heat exchanger to the water in the CH installation. The rapid cooling off of the flue gases causes condensation. This results in a very high efficiency. The condensate that is formed, has no negative impact on the heat exchanger and its operation, and is removed through the internal syphon.

The boiler is equipped with an intelligent control system: CMS (Control Management System). Each boiler anticipates the heat demand of the heating installation or hot water demand. This will cause the boiler to tune its capacity to the installation. This means that the boiler will function longer and at a low level.

If an outside sensor is connected, the control system is able to function, depending on the weather. This means that the control system measures the outside temperature and the supply water temperature. On the basis of this information the control system calculates optimum supply water temperature required for the installation.



The boiler has been tested according to valid CE standards and has a CE certificate and SEDBUK A-rating.

Statement: No banned materials including asbestos, mercury, CFC's have or will not be included in the product.

5 Mounting the boiler

The room where the boiler will be placed must always be frost free. The boiler casing is splash water tight (IPX4D) and is suitable to be installed in e.g. a bathroom.

It is NOT necessary to have a purpose provided air vent in the room or internal space in which the boiler is installed. Neither is it necessary to ventilate a cupboard or compartment in which the boiler is installed, due to the extremely low surface temperature of the boiler casing during operation. Therefore the requirements of BS 6798, Clause 12, and BS5440:2 may be disregarded.

The boiler can be mounted practically to any wall with the suspension bracket and the enclosed fixing equipment. The wall must be flat and of sufficient strength in order to be able to carry the boiler weight with its water content.

Above the boiler there must be at least 250 mm working space in order to be able to fit a coaxial flue system or a twin supply. On the left side of the boiler at least 50 mm and on the right side 10 mm must be reserved to allow fitting or removing of casing. The location of the boiler can be determined by using the template.

Before hanging up the boiler remove the cover of the boiler first. The cover is also the air cabinet and is attached to the rear wall with four quick fasteners (A, B, C and D) (see figure 1).



Secure the quick fasteners with the screws (A, B, C and D) at the back of the cover.

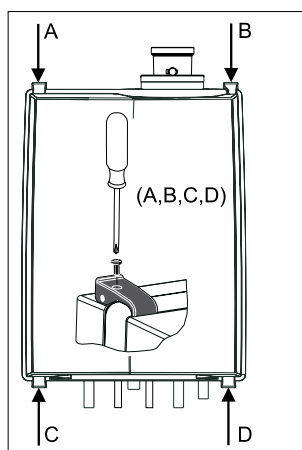

Figure 1



Lift the boiler only by the boilers rear wall.

Lifting and carrying precautions:

- Lift only a manageable weight, or ask for help.
- When lifting the boiler, bend the knees, and keep the back straight and feet apart.
- Do not lift and twist at the same time.
- Lift and carry the boiler close to the body.
- Wear protective clothing and gloves to protect from any sharp edges.

5.1 Dimensions

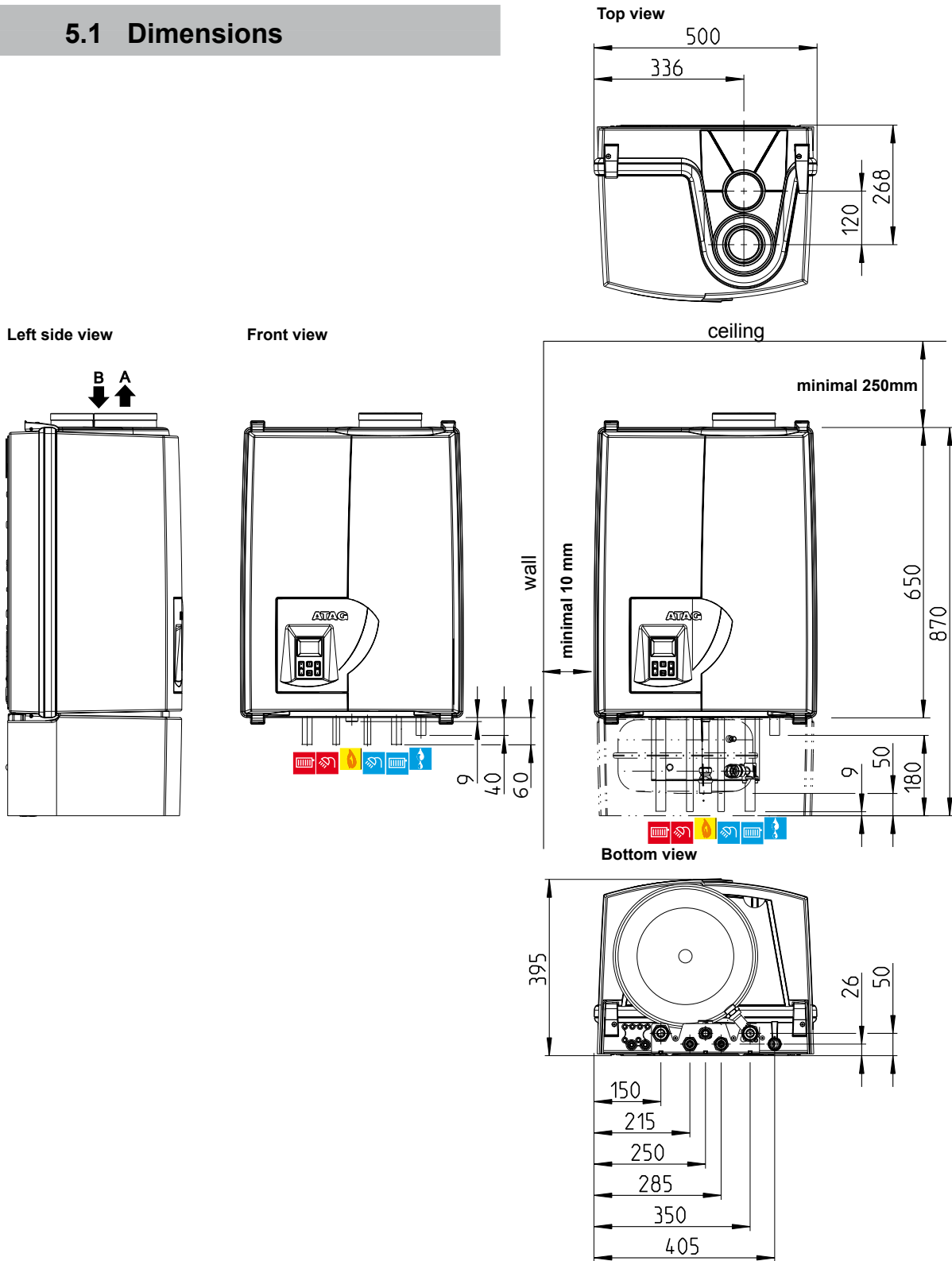

			ATAG A-Series				
			A203C	Combi A325C	A325ECX	A200S	Solo A320S
	Flue gas / Air intake	A/B mm	60/100	60/100	60/100	60/100	60/100
	Gas connection		½" int.	½" int.	½" int.	½" int.	½" int.
	CH Flow connection	mm	22	22	22	22	22
	CH Return connection	mm	22	22	22	22	22
	Condensate drain connection	mm	22	22	22	22	22
	Cold water connection	mm	15	15	15	n.a.	n.a.
	DHW connection	mm	15	15	15	n.a.	n.a.

connection diameters

table 2

6 Connecting the boiler

The boiler has the following connection pipes;

- The central heating pipes.
These can be connected to the installation by means of compression fittings / adapter fittings;
- The gas pipe.
It is provided with a female thread into which the tail piece of the gas valve can be screwed;
- The condensation drain pipe.
It consists of a 22mm plastic pipe. The drain pipe can be connected to this by means of an open connection. If the open connection is fitted in a different location, then the pipe can be lengthened by means of a 32 mm PVC sleeve;
- The flue gas exhaust system and air supply system.
It consists of a concentric connection 60/100 mm.
- Cold and hot water pipes.
Only Combi boilers: *These consist of 15 mm copper pipe and can be connected to the installation by means of compression fittings / adapter fittings.*



It is recommended that isolation valves are fitted to all heating and hot water connections to facilitate ease of future maintenance.



It is advisable to spray-clean all of the boiler's connecting pipes and/or to spray-clean/blow-clean the installation before connecting it to the boiler.

6.1 Central heating system

Connect the central heating system according to the current regulations.

The boiler pipes can be connected to the installation by means of compression fittings. For connecting to thick-walled pipe (welded or fitted), adapters should be used.



When removing the plastic sealing caps from the pipes, contaminated testing water may be released.

The boiler has a self-adjusting and self-protecting control system for the load. This involves checking the temperature difference between the supply and return water. Table 3 shows the water displacement a circulation pump can deliver for a particular installation resistance.

Boiler type	Pump type	Water flow rate at ΔT 20°C		Permissible installation resistance	
		l/min	l/h	kPa	mbar
A203C	UP 15-50	13	790	28	280
A325C	UP 15-60	18	1090	20	200
A325ECX	UP 15-60	18	1090	20	200
A200S	UP 15-50	13	790	28	280
A320S	UP 15-60	18	1090	20	200

Installation resistance

table 3

If the installation resistance is higher than the value stated, the control system will adjust the load until a temperature difference between supply and return water is reached that is acceptable for the control system.

When the temperature difference still remains too high the boiler will switch itself off and wait until the high temperature differential between the flow and return water has decreased again.

The control system will, if an unacceptable temperature difference is detected, repeatedly try to establish a water flow. If this does not succeed, the boiler will block itself (c1 54).

If all, or a substantial part of the radiators have thermostatic radiator valves, an automatic by-pass valve should be used to prevent flow rate problems. The automatic by-pass valve used should have the same diameter as the connecting diameter of the supply and return pipe of the boiler. See also chapter 5.1.



The boiler is NOT equipped with a built-in internal filter.

Advice: ATAG Heating UK Ltd recommend the installation of an in-line filter installed into the heating return as close to the boiler as possible. ATAG Heating UK Ltd recommend the use of either:

Adey Magnaclean filters

or

Fernox TF1.



The boiler is not suitable for installations that are equipped with “open” expansion tanks.



Additives in the installation water are only permitted in consultation with the country distributor. ATAG Heating UK Ltd recommend the use of either Fernox or Sentinel products.

6.2 Expansion vessel

The boiler is equipped with a built-in expansion vessel.

The A203C and A200S have a capacity of 8 litres with a pre-pressure charge 0.8 bar, whilst the A325C, A325ECX and A320S have a capacity of 12 litres with a pre-pressure charge of 1 bar. If the expansion vessel size is insufficient for the CH system, an additional expansion must be installed. The additional expansion vessel should, together with the built-in expansion vessel, be sized to the water content of the installation. The pre-pressure charge depends on the height of the installation above the installed expansion vessel. See Table 4.

installation height above the expansion vessel	pre-charge pressure of the expansion vessel
5 m	0,5 bar
10 m	1,0 bar
15 m	1,5 bar

expansion vessel

table 4



The expansion vessel should be connected as closely as possible in the return near the boiler.

6.3 Heating systems with plastic pipes

When connecting or using an underfloor heating system, designed with plastic pipes, or plastic pipes are used elsewhere in the installation, one should ensure that the plastic pipes used comply with the DIN 4726/4729 standard. It is set out in this standard that the pipes may not have oxygen permeability higher than 0.1 g/m³.d at 40°C. If the system does not comply with this DIN standard, the underfloor heating component will have to be separated from the central heating appliance by means of a plate exchanger.



No recourse can be made to the terms of the warranty in the event of failure to observe the regulations pertaining to plastic underfloor heating pipes.

6.4 Gas connection

The appliance pipe is fitted with an internal thread, into which the tail piece of the gas tap can be screwed.

United Kingdom:

The gas supply must comply to the current Gas Safety, Installation & Use Regulations.

Ireland:

- Irish standard 813
- Domestic gas installations

The connection to the appliance must include a suitable method of disconnection and a gas control cock must be installed adjacent to the appliance for isolation purposes. The nominal inlet working gas pressure measured at the appliance should be 20 mbar for Nat gas (G20).



Make sure that the gas pipe work does not contain dirt, particularly with new pipes.



LPG

When the boiler has to be converted from natural gas to LPG, ATAG provides special kits for this purpose. Special instructions are supplied with the kit.



Always check the installation of all of the parts through which gas flows (using leak-search spray)

6.5 Hot water supply (DHW Combi boilers)

Connection of the drinking water installation should be done according to the national water laws.

The ATAG A Combi boilers are fitted with a stainless steel plate heat exchanger for producing domestic hot water. The boiler does not have a hot water store and in case of a demand for hot water the boiler will heat the domestic water flowing through the plate heat exchanger up to 60°C instantaneous.

The water mains installation must comply with the British water regulations.



In regions with a water hardness value higher than 267ppm (2,67 mmol/l), calcium deposits should be removed from the plate heat exchanger on a regular basis. If problems occur when using sanitary water with a chlorine content higher than 150 mg/l, no recourse can be made to the terms of the warranty.

In order to prevent calcification ATAG recommends applying a water softener. ATAG recommends the use of for instance AlphaPhos for cleaning plates exchangers.

The hardness of the water is variable in Great Britain and Ireland. The water company can provide exact information about this.

The domestic water pipes can be connected to the installation by means of compression fittings / adapter fittings. The cold water inlet on the Combi boilers must be provided with the following (counted in the water flow direction):

- Dosing valve (supplied),
- Safety group,
- Expansion vessel 6bar (potable water, blue).

In the cold water pipe in the boiler a dosing valve (supplied loose) can be installed if required. The dosing valve ensures that a quantity of water supplied has a guaranteed temperature of 60 °C (assuming a cold water temperature of 10°C). The amount of water is virtually unaffected by the water pressure.

After installation, check the hot water flow rate with a fully opened hot water tap,

If required the dosing valve can be fitted as follows:

- Turn off the mains water supply to the boiler
- Open a hot water tap to depressurise the hot water pipe
- Remove the boilers front cover
- Undo with a closed wrench or size 15 ring spanner the dosing valve plug fitting
- Insert the dosing valve according figure 3. O-ring should point downwards
- Refit the plug fitting
- Turn on mains water inlet and purge water through all taps
- Replace the boilers front cover.

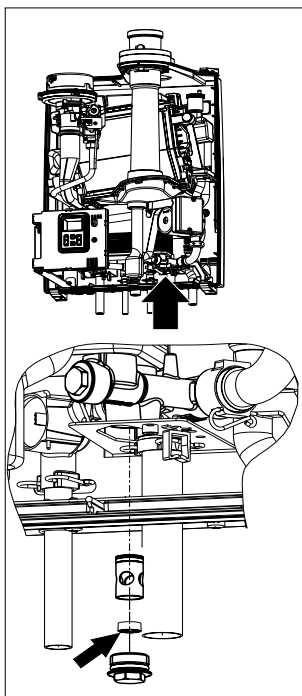

Dosing valve

Figure 3

6.6 Condensation drain pipe

ATAG Condensing boilers have the top SEDBUK band A Classification for high energy efficiency in heating and domestic hot water.

All ATAG wall hung gas fired condensing boilers contain a syphonic condensate trap to collect and release condensate.

The amount of condensate formed is determined by the type of boilers and the water temperature produced by the boiler.

Condensate pipework.

Use plastic pipework of a diameter no less than 25mm.

Routing of the pipework.

Wherever possible, the condensate pipework should be routed internally to prevent freezing.

The condensate pipework must fall at least 50mm per metre towards the outlet and take the shortest possible route

Support the pipe at least every 50 cm for near horizontal sections and 1 metre for vertical sections

External pipework

The pipework should be kept to a minimum and the route as vertical as possible. Do not exceed 3 metres outside the dwelling.

The condensate pipe must be run using suitable corrosion resistant materials (eg. plastic).

Terminate as close to the ground or drain as possible (below the grating and above the water level) while still allowing for safe dispersal of the condensate.

Connection of a condensate drainage pipe to a drain may be subject to local building controls.

Pipework subjected to extreme cold or wind chill conditions should be in a 40mm diameter pipe.

Protect all external pipework with weather resistant insulation and, if necessary, box in, to reduce the risk of freezing.

Making it safe.

Condensate pipework must not leak, freeze or block up.

Condensate traps must be filled before firing the boiler to prevent the possibility of potential harmful flue products evacuating via the condensate route.

Do not dispose condensate into a water recovery system where it is reclaimed for reuse.

Condensate can be discharged into a rainwater hopper which is part of a sewer carrying both rain water and foul water.

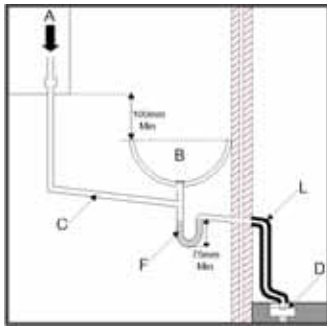

Final discharge options.

The condensate pipe can only terminate into any one of the five areas as shown in the diagrams on this page.



Draining of the condensation water to the external rain guttering is not permitted in view of the danger of freezing.



Before putting the boiler into operation fill the syphon with 300 ml of water.

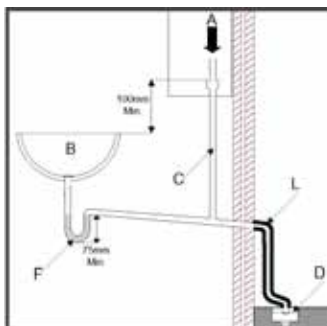
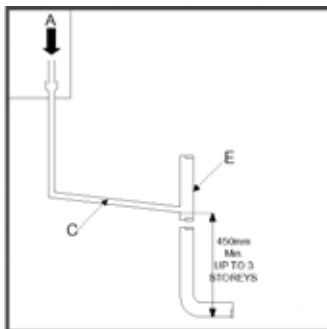
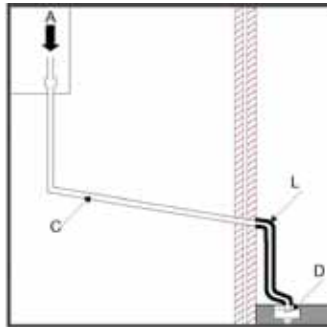

- A -Condensate from boiler syphon/trap
- B -Sink with internal overflow
- C -25mm dia. Plastic condensate pipe
- D -External drain or gully
- E -Internal soil and vent stack.
- F -Servicable condensate trap (75mm min.)
- G -300mm x 100mm dia. sealed plastic tube.
- H -Ground level
- J -Drainage holes facing away from the building
- K -Lime stone chippings
- L -Weather resistant insulation

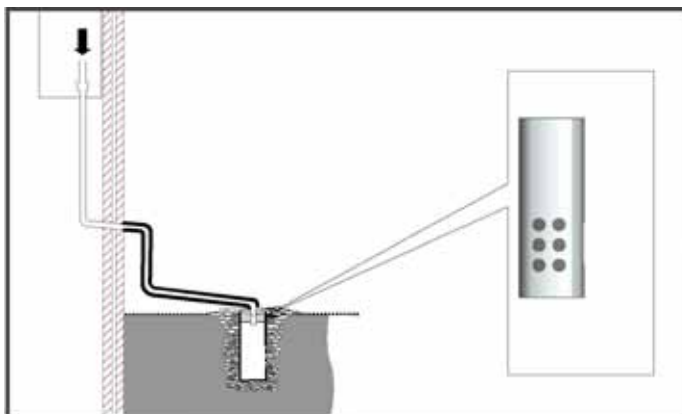

Drain requirements

figure 4

6.7 Flue gas exhaust system and air supply system

The flue gas exhaust system and air supply system consists of:

- Flue gas pipe;
- Air supply pipe;
- Roof or wall terminal.

The flue gas exhaust system and air supply system must comply with:

United Kingdom:

The flue gas outlet and air supply installation must comply with the current regulation requirements. IG UP 10 and BS 715.

Ireland:

- Irish standard is 813 section 9.10.1



The ATAG A boilers as described in this manual are pre fitted with a flue non-return valve. Always contact ATAG if you want to use the boiler together with a combined flue system. Permittance upfront from ATAG is required otherwise no recourse can be made.

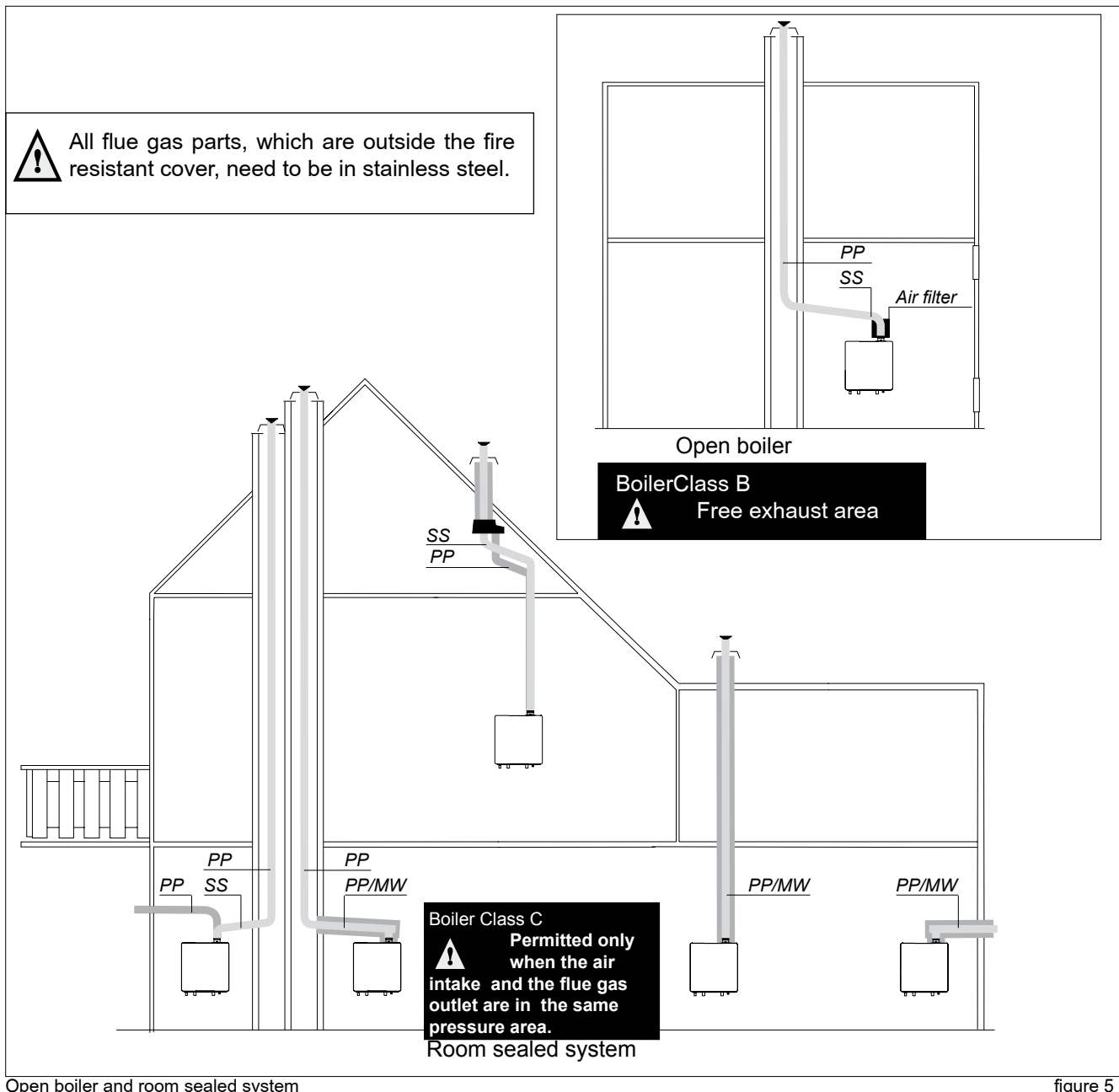

Open boiler and room sealed system

figure 5

The appliance concentric connection diameter is 60/100 mm, to which the flue gas outlet and air supply system can be fitted, with or without elbow pieces. The maximum permissible pipe length is set out in Table 5.

Boiler conversion from concentric to parallel

It is also possible to use a parallel pipe connection of 2x 80mm. In this case a conversion kit 'concentric tot parallel' should be ordered. Art.nr. S4440520.

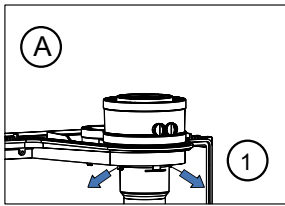

- A. 1. Push the 2 clips slightly outwards.

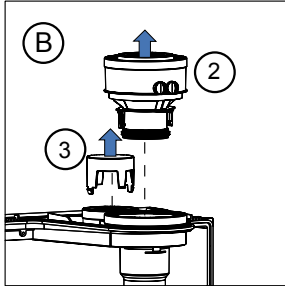

- B. 2. Pull the concentric adaptor out of the boiler.
3. Press the cover in the connection at the back from inside out.

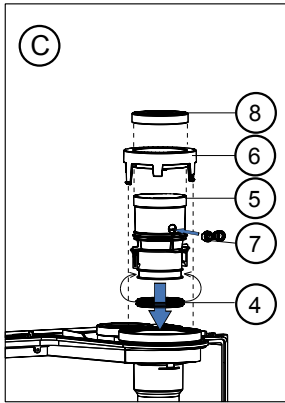

- C. 4. Pull the rubber seal around the bottom of the flue connector.
5. Push the flue connector in the boiler, in the boiler flue pipe until 'CLICK'.
6. Push the $\varnothing 125\text{mm}$ cover over the flue connector in the $\varnothing 125\text{mm}$ opening until 'CLICK'.
7. Push the rubber plug in open position in the O₂ measuring opening and close the stop.
8. Push the gasket around the top of the flue connector.

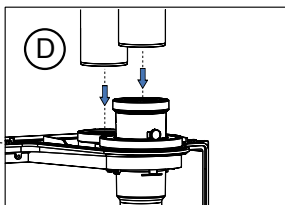

- D. Connect the parallel flue gas and air intake system (2x $\varnothing 80\text{mm}$).

boiler conversion from concentric to parallel
figure 6



We suggest you design a simple flue gas system and air supply system using table 6. For further information about the available components of the flue gas and air supply system we recommend you consult the Monopass Flue system literature.

The ATAG flue gas system is meant, and designed, solely for the use on ATAG central heating boilers adjusted to Nat gas or LPG. The maximum flue gas temperatures are below 70°C (full load 80/60°C)

The proper operation may be adversely influenced by changes of or adjustments to the correct set up.

Possible warranty claims will not be honoured if incorrect changes result in non compliance with the installation manual or local rules and regulations.

The flue gas systems described in this document are solely suited for ATAG central heating boilers of the ATAG boiler range. For this purpose the CE Certificate has been supplemented under the Gastec nr: 0063BR3405, 0063BQ3021, 0063AS3538 and 0063AU3110.

The flue gas system should be built up using only ATAG program products. Combinations with other brands or systems are, without written permission from ATAG Heating, not permitted.

The terminal should be located where dispersal of combustion products is not unimpeded and with due regard for the damage or discolouration that might occur to parts of the building in the vicinity (see fig 7).

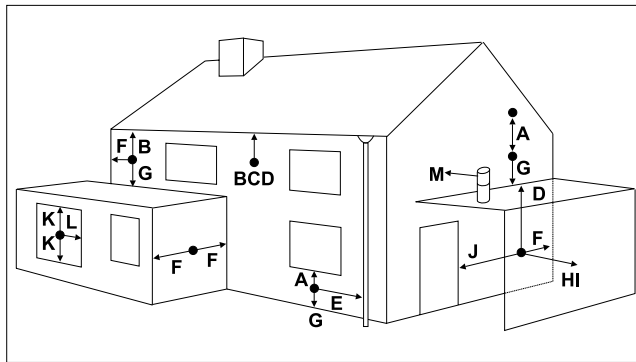

figure 7

terminal position for fan assisted boiler		minimum distance
A	directly below an open window or other opening (e.g. air brick)	mm 300
B	below gutters, soil pipes or drain pipes	mm 75
C	below eaves	mm 200
D	below balconies or car port roof	mm 200
E	from vertical drain pipes and soil pipes	mm 75
F	from internal or external corners	mm 300
G	above ground or below balcony level	mm 300
H	from a surface facing a terminal	mm 600
I	from a terminal facing a terminal	mm 1200
J	from an opening in the car port (e.g. door window) into dwelling	mm 1200
K	vertically from a terminal on the same wall	mm 1500
L	horizontally from a terminal on the same wall	mm 300
M	horizontally from a vertical terminal to a wall	mm 300

Dimensions

table 6

In certain weather conditions condensation may also accumulate on the outside of the air inlet pipe. Such conditions must be considered and where necessary insulation of the inlet pipe may be required.

In cold and/or humid weather water vapour may condense on leaving the flue terminal. The effect of such 'plumeing' must be considered.

The terminal must not be located in a place where it is likely to cause a nuisance. For protection of combustibles, refer to IS 813 section 9.10.1. where the terminal is less than 2m (6.6ft) above a pavement or platform to which people have access (including) any balcony or flat roof. The terminal must be protected by a guard of durable material. A suitable guard is available from the country distributor.



Where a terminal is fitted below a window which is hinged at the top, and where the hinge axis is horizontal, and the window opens outwards, the terminal shall be 1m below the bottom of the window opening.



If the boiler is to be located under stairs, a smoke alarm meeting the requirements of I.S. 409 or equivalent must be fitted.



The flue must be terminated in a place not likely to cause a nuisance.

For horizontal sections, the outlet system should always be fitted on an incline (50 mm/m) sloping down towards the appliance so that no condensation water is able to accumulate in the outlet system. The chances of icicles forming on the roof outlet is minimised by causing the condensation water to run back towards the appliance. In the case of horizontal outlets the inlet system should be fitted on an incline sloping down towards the outside to prevent rainwater from coming in.

The appliance produces a white wisp of condensation (plumeing). This wisp of condensation is harmless, but can be unattractive, particularly in the case of outlets in outside walls.

At this time there are 2 different ways of connecting the flue gas/air intake system. The flue gas duct for the 60/100, 80/125 and 100/150 are push fit connections, see figure 10. The air intake for the 60/100 is a clamp ring connection.

These two types are not interchangeable.

Cutting the pipe goes as follows:

- Take out the inner tube by turning it until it releases from its security position;
- Cut just as much from the air intake part as from the flue gas part;
- Take off the burrs from the cutting edge to prevent cutting the seals;
- Click the pipes back together again.

Use special grease to simplify the fitting

When mounting the flue gas system, pay attention to the flow direction. An arrow on the product points this out. It is not permitted to mount a system upside down and will lead to complaints.

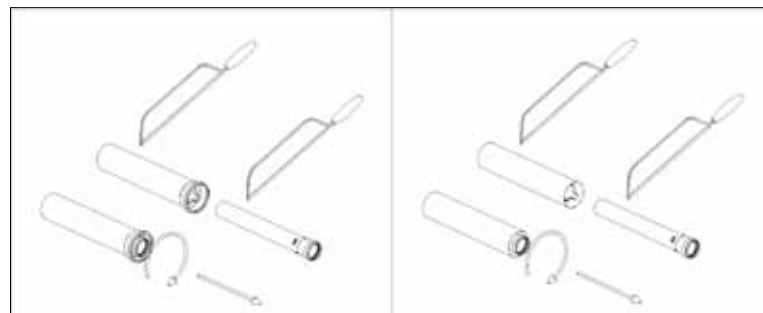
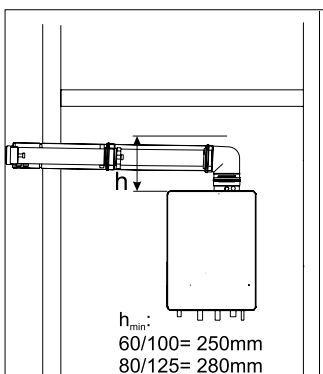

Dismantlement and shorten pipes

figure 8

6.7.1 Dimensioning of the flue gas and air intake duct

The flue diameter is determined by the total length of the run, including for the connection pipe, elbows fittings and terminal covers etc and the type and number of boilers installed into the system.

An undersized flue pipe can lead to disorders. Look at table 1 for the choice of the system and the correct diameter. The table below shows the maximum flue lengths with the different boiler outputs. A longer flue gas length can be achieved by increasing the diameter to \varnothing 100mm.

Example:

An A203C with a concentric flue gas system \varnothing 60/100mm has according to the table a maximum flue straight length of 6m. In the system that is going to be put in there are 2 x 45° bends, so the maximum flue gas length is

$$6 - (2 \times 1) = 4 \text{ meters.}$$

Explanation table 1:

Two pipe flue gas system: maximum noted length = distance between boiler and terminal A

Concentric flue gas system: maximum noted length = distance between boiler and terminal B

When using bends the noted value behind every bend should be deducted from the maximum straight length.

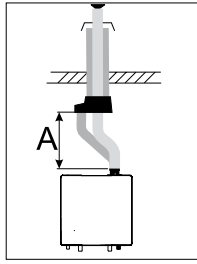

Two pipe flue system + chimney lining $\varnothing 80\text{mm}$				
	$\varnothing 80\text{mm}$	A in m		
A200S	Maximum straight length 80	35,5		
A203C	87° bend resistance length	-1,5		
	45° bend resistance length	-0,8		
A320S	Maximum straight length 80	24		
A325C	87° bend resistance length	-1,5		
A325ECX	45° bend resistance length	-0,8		

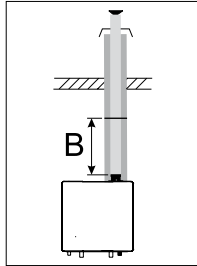

Concentric flue system $\varnothing 80/125\text{mm}$				
	$\varnothing 80/125\text{mm}$	B in m		
A200S	Maximum straight length 80/125	30		
A203C	87° bend resistance length	-2,8		
	45° bend resistance length	-1,1		
A320S	Maximum straight length 80/125	18		
A325C	87° bend resistance length	-2,8		
A325ECX	45° bend resistance length	-1,1		

Concentric flue system $\varnothing 60/100\text{mm}$				
	$\varnothing 60/100\text{mm}$	B in m	Correction factor fan speed See chapter 'Settings'	Par. 683
A200S	Maximum straight length 60/100	15	Correction factor 15 meter	6
A203C	87° bend resistance length	-1,6	Correction factor 12 meter	4
	45° bend resistance length	-1	Correction factor 10 meter	3
			Correction factor 8 meter	2
			Correction factor 6 meter	1
			Correction factor 4 meter	0
A320S	Maximum straight length 60/100	15	Correction factor 15 meter	12
A325C	87° bend resistance length	-1,6	Correction factor 12 meter	9
	45° bend resistance length	-1	Correction factor 10 meter	7
			Correction factor 8 meter	5
			Correction factor 6 meter	4
			Correction factor 4 meter	2
A325ECX	Maximum straight length 60/100	15	Correction factor 15 meter	9
	87° bend resistance length	-1,6	Correction factor 12 meter	7
	45° bend resistance length	-1	Correction factor 10 meter	5
			Correction factor 8 meter	4
			Correction factor 6 meter	2
			Correction factor 4 meter	0

When using a concentric flue system $\varnothing 60/100\text{mm}$ with a maximum length between 4 and 15 meters a correction must be made to the fan speed by adjusting Parameter 683 according to the table. Fill out the correction factor on the sticker below the control panel. See chapter 'Settings' how to adjust a parameter setting.

Dimensions flue gas system and air supply system

Table 5

NOTE! ADJUSTED PARAMETER SETTING FOR FAN SPEED	
- See Installation instructions for more details -	
Correction factor fan speed (parameter 683)
Adjusted by
Date

Example correction factor sticker

7 External hot water cylinders (Solo boilers)

Depending on the comfort preferences different external hot water cylinders can be connected to the system boiler. The choice of the cylinder depends on the coil output. The coil output must comply with the boiler output.

The A-Series is provided with an internal DHW control. The electrical connection can be made in the boiler. To connect a cylinder to the A-Series boiler you need to order the following optional articles:

- AA05104U ATAG three way valve / Stepper
- AA05204U ATAG cylinder sensor.

Only these articles are suitable for this purpose. Please contact ATAG Heating Ltd.

The wiring of the three way valve and cylinder sensor must be connected to the boiler according to the instructions supplied with these articles. See also page 22.

If desired a DHW on/off thermostat (volt free) can be used instead of the DHW sensor. Use the separate 2-core connector on the back of the control unit for this connection. See also page 22.

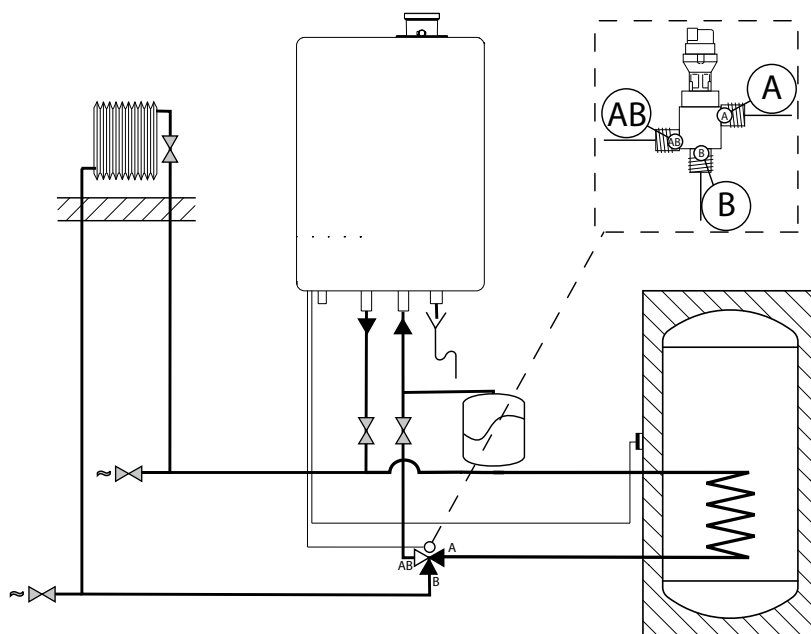
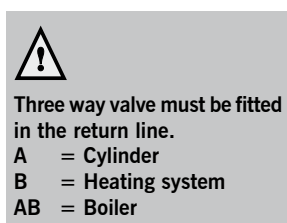

ATAG A solo with external cylinder

Figure 9

8 Electrical connection

The appliance complies with the CE Machinery Directive 89/392/EEC. The EC Low Voltage Directive 72/23/EEC and the EC EMC Directive 89/336/EEC.

- A 230V -50Hz mains electrical supply is required fused externally at 5A.
- A deviation on the grid of 230V (+10% or -15%) and 50Hz

The installation must continue to comply with:

United Kingdom:

- the national rules for electrical installations.

Ireland:

- the ECTI national rules for electrical installations

The appliance must be connected to an earthed socket. this must be visible and within reach.

The following general stipulations also apply:

- No changes may be made to the wiring of the appliance;
- All connections should be designed in accordance with the enclosed regulations.;
- Only Combi: Should it be necessary to change it, the mains power supply cable may only be replaced with an ATAG mains power supply cable (item No. S4477300).

The power supply cable for Solo boilers must be supplied and fitted by the installer to connection terminal X21.

8.1 Room thermostat



Z-ready

This logo represents the Z thermostats from ATAG. For communication with the boiler the boiler must be provided with a connection for the corresponding communication protocol. Such ATAG boiler can be recognized by this logo. You can find this logo on the packaging, the casing and documentation of these products.

To the ATAG A 2 kinds of room thermostats can be connected:

- A. For optimal use of the boilers control ATAG advises:
Position 1 and 2: ATAG Z thermostat.
- B. As an alternative:
Position 3 and 4: Only battery powered on/off room thermostats (volt free).
- C. Only Solo boiler:
230Volt: Connect the 230Volt switched live to terminals X21.
Note the polarity!

The thermostat must have a 2-wire connection.

The room thermostat has to be connected to the terminal block. Use the screw connector that has been connected onto the terminal block.

Lead the cable from the room thermostat along the upper cable hooks of the housing and the hing bracket.

For more detailed questions about components that have not been supplied by ATAG, contact the vendor concerned.

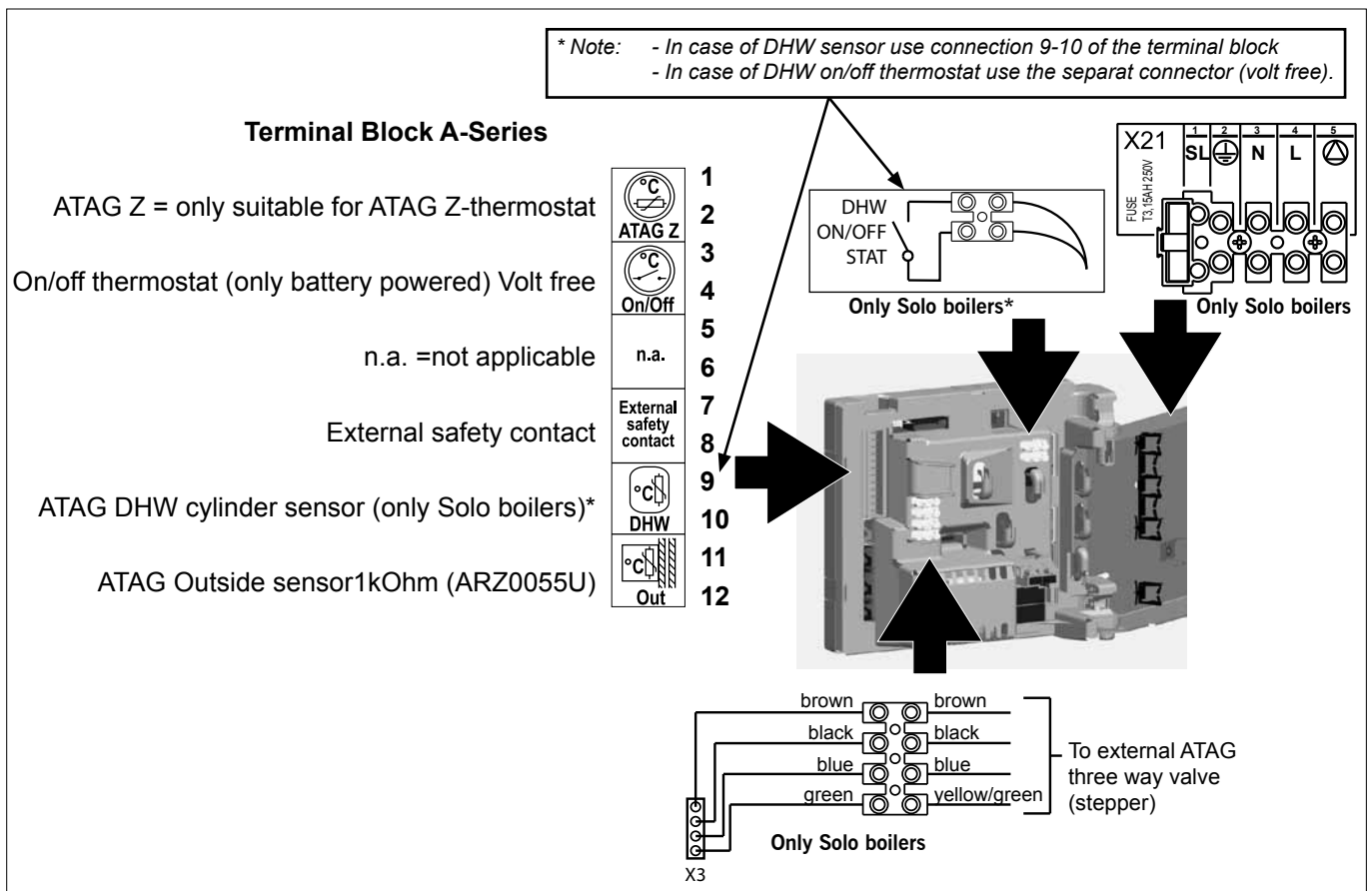

terminal block

Figure 10

8.2 Electrical diagram Solo boilers

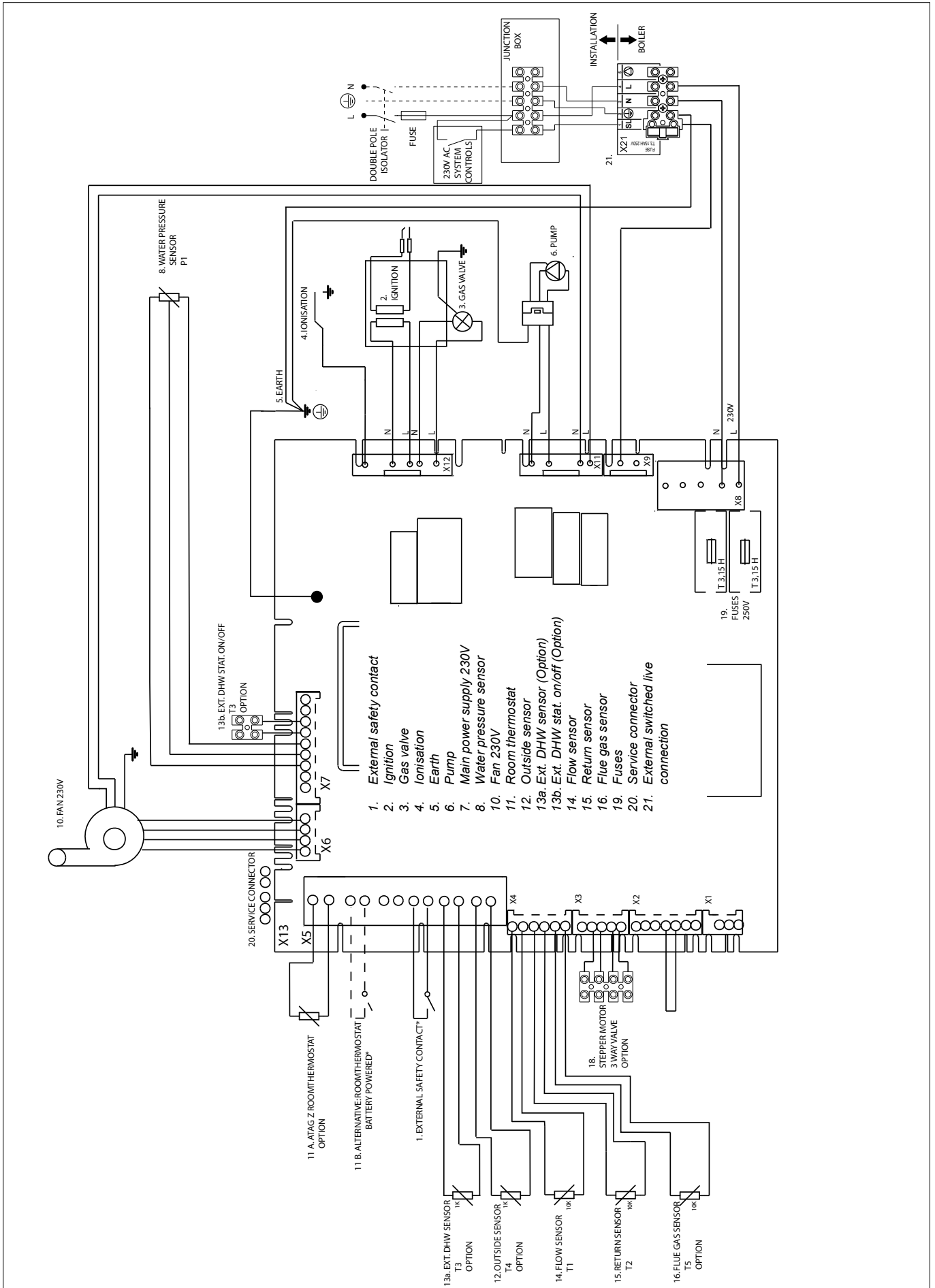
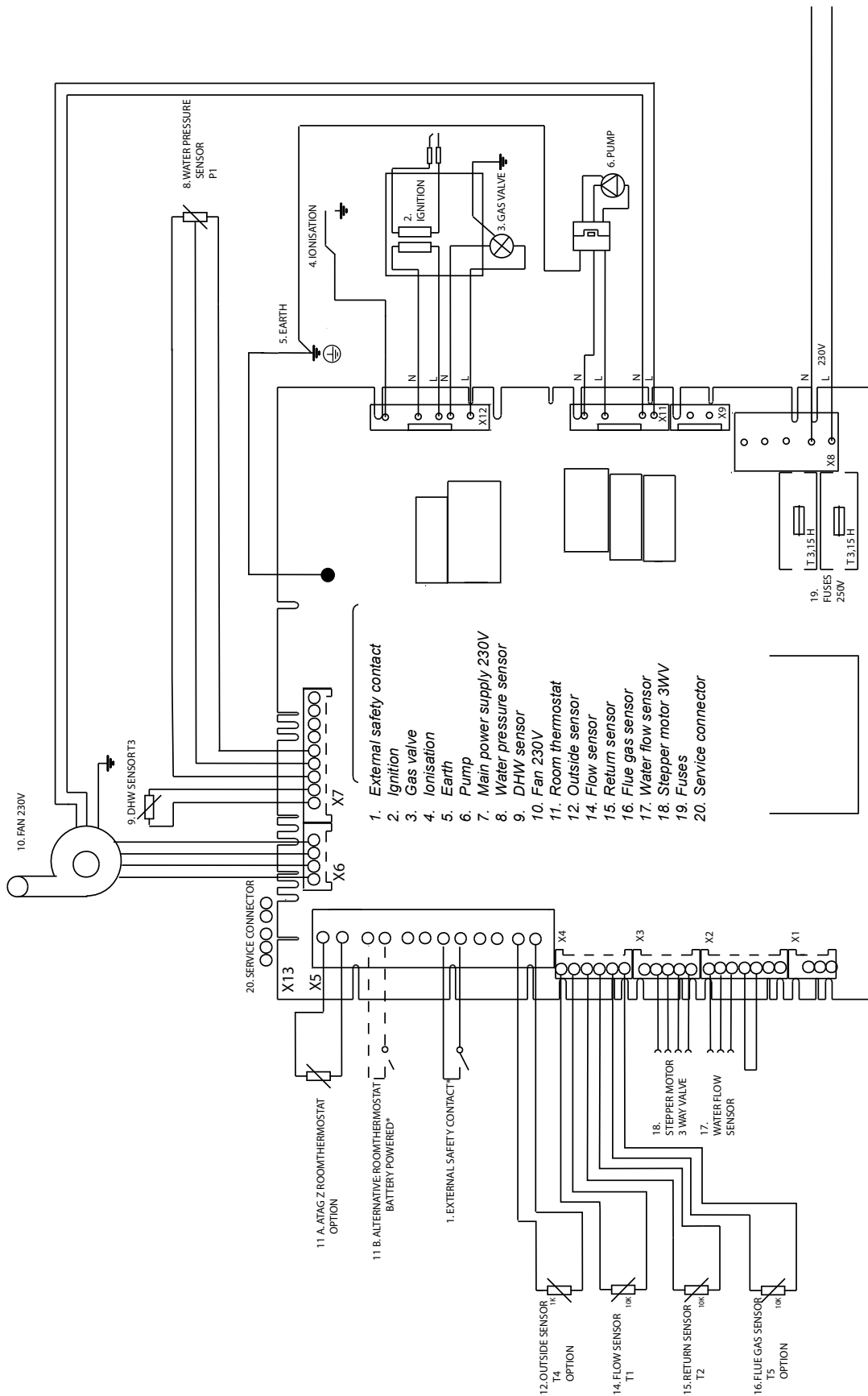

Figure 11a

8.3 Electrical diagram Combi boilers



9 Filling and bleeding of boiler and CH installation

The central heating installation needs to be filled with potable water. For filling or topping up the installation use the filling loop according to the following procedure:

- 1 Turn on the boiler mains electrical supply;
- 2 the start up procedure the display will read c1 18 (low water pressure).
- 3 Connect and open the filling loop;
- 4 Slowly fill the system up to 1.5 – 1.7 bar;
(press the i button until A6 is displayed.
Water pressure: value on the display increases)
- 5 Close the filling loop;
- 6 C1 05 appears on the display the moment the pressure exceeds 1.3 bar;
- 7 The 7 minute de-aeration cycle begins;
- 8 Vent the entire heating installation starting at the lowest point;
- 9 Check the water pressure and top up if necessary to 1.5 – 1.7 bar;
- 10 Disconnect and cap the filling loop;
- 11 Following the completion of the 7 minute de-aeration cycle [C1 05] the boiler will switch on for the enabled program.



It may take some time before all the air has disappeared from a filled installation. Certainly during the first week sounds may be audible that indicate air. The automatic air vent in the boiler will let this air escape, causing the water pressure to drop during this period and water will need to be refilled again.

9.1 Hot water supply (combination boilers)

Fill the hot water supply by opening the cold mains isolation valve.

Bleed the hot water installation by opening all hot water taps one at a time. Leave each tap to run until all air has disappeared from the supply.

Flush with a minimum of 10 litres to rinse any residual contaminants from the hot supply and boiler.

Before the plug is inserted into the wall socket, it helps to know the operation of the boiler in advance. On this page the controls are described in short. The next page describes the key functions and the symbols on the display.

The boiler is equipped with self-managing control system, the so-called Control Management System. This control system takes over a large part of the manual settings, which simplifies the start-up on the installation considerably.

After filling the installation the automatic de-aeration program is activated. The automatic de-aeration program lasts for approx. 7 minutes and stops automatically. Then the boiler will switch on for the enabled program (CH or HW)(See 'Filling and bleeding boiler and installation').

Hot water controls (combination boilers)

If hot water is tapped the flow sensor measures (F1) the amount tapped. Depending on the desired tap water temperature and tap volume the controls will calculate a supply temperature. This realises the desired water temperature in an efficient way. The hot water sensor (T3) will adjust any minor deviations caused by fluctuations in the supply tap water temperature so that even under these circumstances the desired temperature is reached.

CH controls

With a demand from the heating controls, the boiler activates its 1 minute delay period. This is to prevent the heat exchanger from losing its heat too quickly in the event of a hot water demand. Then the pump starts and after 30 seconds the gradient control becomes active. The starting point of the gradient control is the currently existing supply temperature. A Delta-T control (25K) ensures a stable control according to heat request.

If the supply temperature is below the T-set value of 20°C the boiler will immediately start.

In case of weather-dependent controls (1kOhm outside ARZ0055U sensor connected) a daily temperature is set instead of a supply temperature. Control will take place according to the heating line.

The ATAG A is equipped with boiler sensors of 10kOhm. The resistance value and corresponding temperature are shown in the accompanying table.

Resistance tabel sensors ATAG A			
NTC1k (25°C)		NTC10k (25°C)	
Temperature [°C]	Resistance [Ohm]	Temperature [°C]	Resistance [Ohm]
-10	4.574	-10	55.047
-9	4.358	0	32.555
-8	4.152	10	19.873
-7	3.958	12	18.069
-6	3.774	14	16.447
-5	3.600	16	14.988
-4	3.435	18	13.674
-3	3.279	20	12.488
-2	3.131	22	11.417
-1	2.990	24	10.449
0	2.857	26	9.573
1	2.730	28	8.779
2	2.610	30	8.059
3	2.496	32	7.406
4	2.387	34	6.811
5	2.284	36	6.271
6	2.186	38	5.779
7	2.093	40	5.330
8	2.004	42	4.921
9	1.920	44	4.547
10	1.840	46	4.205
11	1.763	48	3.892
12	1.690	50	3.605
13	1.621	52	3.343
14	1.555	54	3.102
15	1.492	56	2.880
16	1.433	58	2.677
17	1.375	60	2.490
18	1.320	62	2.318
19	1.268	64	2.159
20	1.218	66	2.013
21	1.170	68	1.878
22	1.125	70	1.753
23	1.081	72	1.638
24	1.040	74	1.531
25	1.000	76	1.433
26	962	78	1.341
27	926	80	1.256
28	892	82	1.178
29	858	84	1.105
30	827	86	1.037
35	687	88	974
40	575	90	915

Resistance table

table 6

10.1 Controls and explanation of the functions

Hot water

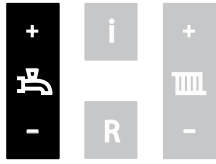

Setting the hot water temperature:

Briefly press + or - ; the display will show the flashing preset value;

Briefly press + or - to change the set value. Each change becomes active directly.

Hot water program OFF: Press - until the lowest value is reached and then press - again.

The display is showing -- and the middle ["<"] is off.

Switching on works in reverse order.

Central heating



Setting the CH water temperature:

Briefly press + or - ; the display will show the flashing preset value;

Briefly press + or - to change the set value. Each change becomes active directly.

CH program OFF: Press - until the lowest value is reached and then press - again. The

display is showing - and the upper ["<"] is off.

Switching on works in reverse order.

Information(i)-key

Requesting current data:

Briefly press the i-button (or the scroll key) in order to obtain the following value:



A0 = Flow water temperature

A1 = Return water temperature

A2 = Hot water temperature

A4 = Flue gas temperature (only if a flue gas sensor is connected)

A5 = Outside temperature (only if an outside sensor is connected)

A6 = Water pressure

A9 = Rpm's of fan

To return to the standard view press ESC.

Reset key



The reset key allows the boiler to restart if a malfunction has occurred.

In case of a failure the ["BELL"] symbol is displayed with a Cx xx code.

In other cases the Reset button does not function and will not respond to operation. See

15 for a brief overview of codes.

Some keys have ancillary functions. These ancillary functions are activated only if, according to the procedure described in Section 11.4, settings need to be changed or data retrieved from the CMS.

Ancillary functions:

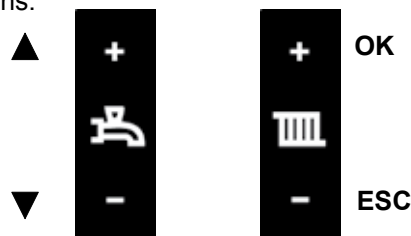

DHW KEY: Scroll function ('scrolling' through parameters)

CH key: OK and ESC function (OK= confirm, ESC= back to standard display)

11 Commissioning the boiler

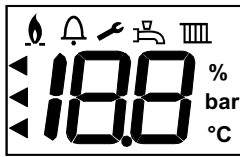

Segmenttest

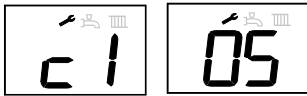

De-aeration program actif

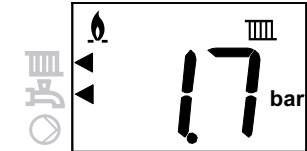

Standard view with device in operation for CH

Make sure before the boiler is put into operation that the boiler and installation have been fully bled. Bleed the gas line and open the gas valve of the boiler. The boiler requires no adjustment of the burner pressure and quantity, because it is self-regulatory and has been set in the factory and should not be reset.

Insert the plug into the wall socket;
There is a start-up procedure with a segment test of the display;
The lights come on and after the segment test go out again;

If the water pressure falls below 1.0 bar c1 18 will appear in the display;
This will disappear again the moment the water pressure is higher than 1.3 bar and the de-aeration program will start (c 1 05).

This will take approx. 7 minutes and will be followed by the standard view.

The boiler will switch on immediately to reach the desired pre-heat temperature of the hot water supply (Comfort setting).

11.1 Hot water supply

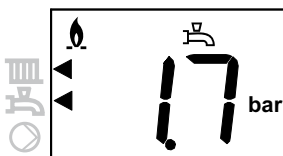

The DHW program is always active after start-up.

This is indicated by the middle ◀.

If there is hot water request, this is indicated by and the hot water supply will be activated. The circulation pump will start circulating and the boiler will switch on . By default the hot water supply is set to Comfort. A change to Eco is possible by means of Parameter 684. See chapter 11.4.

11.2 CH system

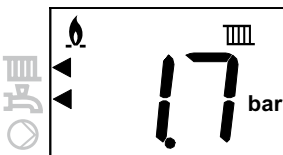

The CH program is always active after start-up.

This is indicated by the upper ◀.

If there is heat request, it is indicated by and the heating will be put into operation . The circulation pump will switch on and the boiler will switch on after 1 to 2 minutes.

11.3 Pump function

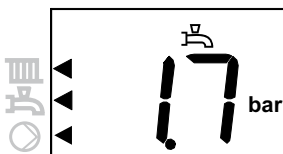

By default the boiler is set in such a manner that the pump will switch on in case of a heat request for CH or DHW. Switching on and off is managed entirely by the control system.

Danger of frost

If there is danger of frost damage to the CH installation and there is no outside sensor connected, it is advisable to let the pump run continuously.

With Parameter 684 the pump can be switched on continuously. See chapter 11.4.

If the pump is set too continuously this is displayed with the lowest ◀ in combination with or .

If no outside sensor is connected, then the controls will regulate the pump:

- In case of outside temperatures between +1.5 and -5°C the pump will run for 10 minutes every 6 hours.
- In case of outside temperatures below -5°C the pump will run in frost protection mode.

11.4 Settings

When the boiler is installed, it is in principle ready to be put into service. All settings of the control system are already programmed for a heating system with radiators/convectors with a flow temperature of 75°C. The settings are described in the parameter chapter on page 30.

There may be cases that the settings have to be changed, for example:

- Lower flow temperature

Use the parameter chapter to set the boiler according to the situation. If in doubt, check with ATAG Heating Ltd.

To change a setting, proceed as follows:

Changing the settings

STEP 1

Press the OK key for 3 seconds.

The display shows 'P6 (alternated with) 81';

STEP 2

Press the OK key for 3 seconds again.

The display shows 'on' shortly followed by 'P5 18';

You now have access to the parameter chapter.

The various parameters are described in the following pages.

To change a parameter, proceed as follows:

Basic actions:

With the Scroll keys you 'browse' through the parameters, in which you can change values

With the Esc key you can always return to the default display

With the OK key you confirm the selected parameter or set the value



STEP 3

Press the scroll key to select another parameter;

STEP 4

Press the OK key if you want to change the selected parameter;

STEP 5

Adjust the value if desired / possible with the + or - key

STEP 6

Briefly press the OK button to confirm the new setting.

The display shows the selected parameter again

STEP 7

Press the ESC key until the default display is shown again:



If during 8 minutes no key is used automatically, the default display is automatically shown on the screen.

Parameter-chapter			
PARA	Factory	Description	Range
518	5	Gradient speed CH	0 - 15
520	5	Night decrease temperature (only active at 100% weather dependant): <i>The day temperature will be decreased by this value</i>	0 - 10 K
532	24	Heating line CH-water temperature (see also heating line graph)	10 - 40
541	max.	Maximum power CH in % <i>Can only be reduced. 0 = low load</i>	0 - max
555		<u>Outside sensor functions (only when outside sensor is connected):</u>	
	off	b0 and b1: no function b2: off = weather dependant control with room thermostata leading and outside temperature on the background on = 100% weather dependant control according day and night heating line <i>contact open = night heating line; contact closed = day heating line; When ON par. 520 is active</i>	on - off
	on	b3: no function b4: frost protection CH <i>from +1.5°C until -5: 10 min./ 6 hour pump on; < -5 °C pump continuously.</i> b5 t/m b7: no function	on - off
651*	1	Do not change	
652*	0	<u>Quick selection CH installation:</u> CH Tmax: 85°C; Gradient: 5; Heating line 24 CH Tmax: 70°C; Gradient: 5; Heating line 19 CH Tmax: 60°C; Gradient: 4; Heating line 15 CH Tmax: 50°C; Gradient: 3; Heating line 11 <i>This parameter copies the choosen value over CH Tmax., P518 en P532. It is a quick selection, where the separate values will be independantly adjustable. After selection this parameter will always show 0.</i>	1 2 3 4
680	0	Service-parameter. Do not change	
681	off	Green button function Dependant of the level the factory settings at selection b7 and OK will be set back, P651 excluded.	on - off
682	off	<u>Dynamic functions:</u> b0: Do not change b1 until b6: no function b7: confirmation Service-parameter	on - off
683	0%	Correction factor fan speed for HP-system See table at flue lenghtes. <i>The adjusted value will increase the fan range with that percentage. Write down this value on the sticker on the boiler.</i>	0 - 20%
684	off	<u>Pump function:</u> b0: pump automatic(= off) or continuously (= on)	on - off
	on	b1: DHW function eco (= off) or comfort (= on) <i>When both selected ON than function 'pump continously' is leading in case of frost danger</i>	on - off

* Remark When an adjustment is made and it is confirmed with OK the boiler will restart and the de-aerationprogramm will start.

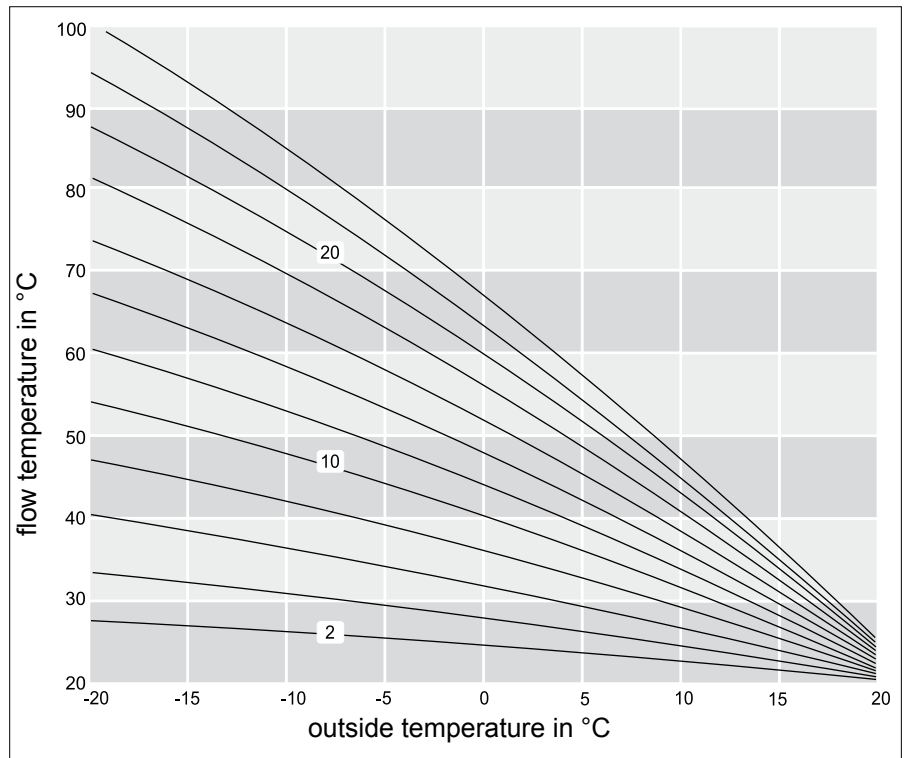

heating line

grafic 1

11.5 Activating the factory setting (green key function)

To re-activate the factory settings, proceed as follows (this will undo all changed settings):

- Select P6 81, according to the procedure described in chapter 11.4;
 - Select b7;
 - Press OK. The screen is showing 'off';
 - Select 'on';
 - Press OK.
- The screen then shows P6 81 and the factory settings are active again.

12 Isolating the boiler

In some situations it may happen that the entire boiler has to be deactivated. With the 2 function keys for the DHW program and the CH program the boiler is put out of service.

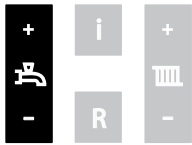

Hot water program OFF: Press – until the lowest value is reached and then press – again. The display shows -- and the middle  is off.

Switching on with the + key takes place in reverse order.



CH program OFF: Press – until the lowest value is reached and then press – again. The display is showing -- and the upper  is off.

Switching on with the + key takes place in reverse order.

ATAG recommends to leave the plug in the wall socket, so that the circulation pump and the three-way valve are activated automatically once every 24 hours in order to prevent jamming.



If there is danger of frost it is advisable in this case to drain the boiler and/or installation.

13 Commissioning



Work on the installation and/or boiler should only be carried out by qualified personnel with calibrated equipment.

For maintenance of the boiler the cover has to be removed. Unscrew the 4 locking screws from the quick fasteners, unlock the quick fasteners and remove the cover in a forward motion.

Changing settings, such as the burner pressure and the amount of air flow, is superfluous. Only in case of a failure or when replacing the gas block, venturi and/or fan, the O₂ percentage should be checked.



Always check all gas carrying parts for leaks (with a leak detection spray) after (maintenance) work to the boiler.

13.1 Checking the O₂



The O₂ percentage is set in the factory. This has to be checked during inspection, maintenance and in case of a failure.

This can be verified by means of the following action:

- Set the external controls to call for heat;
- Make sure the boiler is operational and can get rid of the heat it produces;
- Calibrate the O₂ gauge;
- Place the lance of the O₂ gauge into the flue gas test point (see Figure 12);
- Press both + keys for 6 seconds.
- The display shows the supply water temperature (blinking);
The boiler will immediately switch to the maximum heating capacity
- The correct O₂ percentage = **4,7%**
- Let the measuring equipment perform the O₂ measurement.
- Adjust, if necessary, the adjustment screw to correct the O₂ value (see fig. 13).

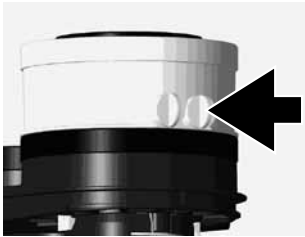

Measuring point O₂

Figure 12

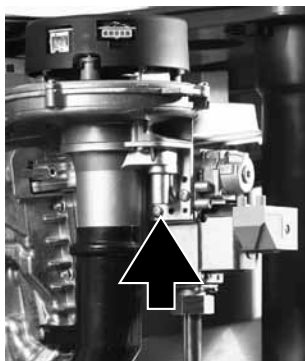
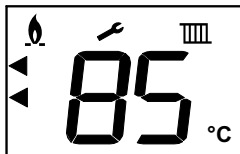

Adjustment screw O₂ Figure 13

Termination of the O₂ measurement:

- - Press the ESC key (- key). The device switches off.
This completes the procedure.

13.2 Maintenance activities

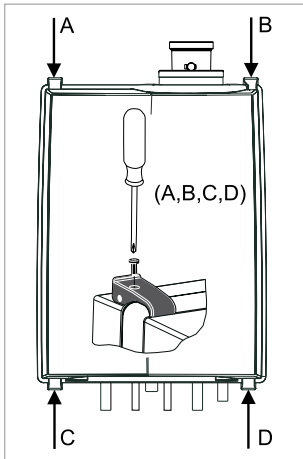

Figure 14

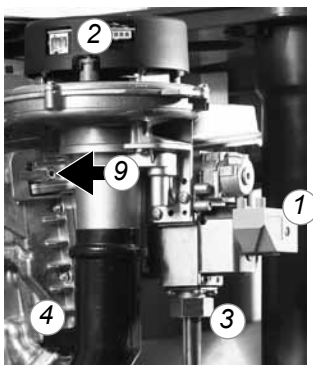

Figure 15

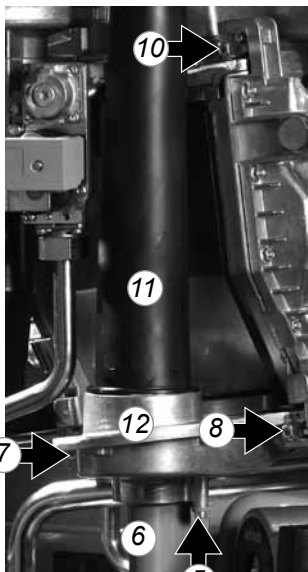

Figure 16

In order to perform maintenance, the following actions have to be taken:

- switch off the boiler;
- remove the screws from the 4 quick fasteners A, B, C and D (see fig. 14);
- unlock the 4 quick fasteners A, B, C and D and remove the cover in a forward motion.

Air box/cover

The cover also doubles as air box:

- Clean the air box/cover with a cloth and a non-abrasive cleaner;

Fan unit and burner cassette (see fig. 15, 16 and 17)

- dismantle the igniter(1) by means of the screw of the gas block;
- pull out the plug connections (2) of the fan;
- unscrew the coupling (3) of the gas block;
- replace the gas block gasket (O-ring) with a new one;
- unscrew the front crosshead screw (4) from the air supply dampener;
- A325ECX only: unscrew the syphon from the economiser (13), check on pollution, clean it and fit the syphon back on the economiser.
- unscrew (5) the syphon (6) and pull it downwards from the condensate tray;
- turn the left (7) and right (8) clamp bar of the condensate tray a quarter turn and pull these out in a forward motion. Note the direction of rotation (red control cams);
- slide the flue pipe (11) or the economiser (A325ECX only) about 1 cm upwards;
- push the condensate tray (12) gently downwards and pull it out from the boiler;
- Pull the flue pipe (11) or economiser (A325ECX only) downwards out of the boiler;
- A325ECX only: hang the economiser with the metal hook on the metal bracket behind the control unit (see fig. 17)
- now turn the left (9) and right (10) clamp bars a quarter turn and pull these out in a forward motion. Mind the direction of rotation (red control cams);
- now remove the complete fan unit with the gas block from the heat exchanger in a forward motion;
- remove the burner cartridge from the fan unit;
- check the burner cassette for wear, pollution and possible fracture. clean the burner cartridge with a soft brush and a vacuum cleaner. in case of a fracture always replace the entire cassette burner;
- replace the gasket between the burner and upper tray and the gasket between the upper tray and the changer;
- check the venturi and gas air dividing plate for pollution and clean them with a soft brush in combination with a vacuum cleaner, if necessary. If the air box is heavily polluted with dust, it is likely that the fan impeller is also polluted. To clean the fan, it has to be removed from the upper tray and the venturi. Clean the impeller with a soft brush and a vacuum cleaner. Replace the gasket and take care that the new gasket is installed properly when reassembling the fan parts.

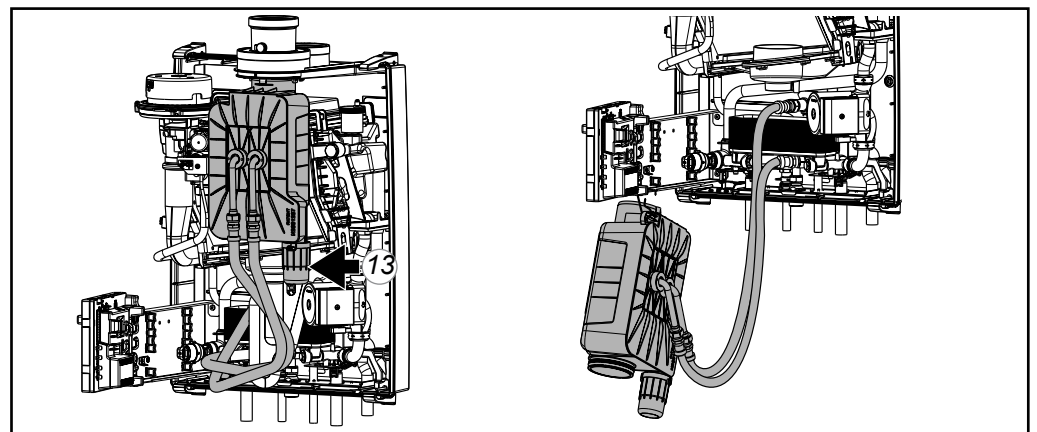

A325ECX with Economiser

Figure 17

Heat exchanger

- check the heat exchanger for pollution. Clean it, if necessary, with a soft brush and a vacuum cleaner. Avoid any pollution falling down.
Top-flushing the exchanger with water is not allowed.

Reassembly takes place in reverse order.



During installation pay attention to the correct position of the clamp bars. These have to be in a vertical position.

Ignition electrode

Replacing the ignition electrode is necessary when the pins are worn. If the inspection hole is damaged, the entire ignition electrode has to be replaced. It is replaced as follows:

- take away the plug connections on the ignition electrode;
- push the clips on either side of the electrode outwards and take away the electrode;
- remove and replace the gasket;

Reassembly takes place in reverse order.

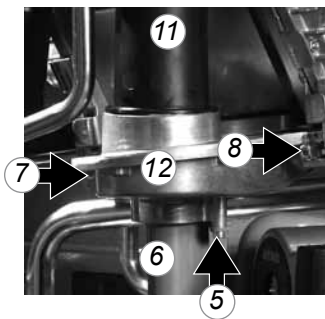

Figure 18

Syphon and condensation tray (see figs. 18, 19 & 20)

- first disassemble the syphon cup (6).
Check it for pollution. If no serious pollution is found in the syphon cup, it is not necessary to disassemble the condensation tray or clean it. If the syphon cup shows serious pollution, the condensation reservoir should be cleaned as well.
- check the O-rings of the syphon cup and replace them if necessary.
- clean the parts by rinsing them with water.
- grease the O-rings again with acid-free O-ring grease to simplify the reassembly.
- If a leakage has occurred to the syphon, replace the entire syphon;
- remove the plug from the flue gas sensor, if any.
- turn the left (7) and right (8) lamp bar of the condensate tray a quarter turn and pull these out in a forward motion. Note the direction of rotation (red control cams);
- slide the flue pipe (11) or the economiser (A325ECX only) about 1 cm upwards;
- A325ECX only: hang the economiser with the metal hook on the metal bracket behind the control unit (see fig. 17)
- now turn the left (9) and right (10) clamp bars a quarter turn and pull these out in a forward motion. Mind the direction of rotation (red control cams);
- now push the condensation tray (11) gently down and take it away in a forward motion;
- replace the condensation tray gasket by a new one.
- clean the polluted condensation tray with water and a hard brush.
- Check the condensation tray for leaks.

Reassembly takes place in reverse order.



Pay attention that the gasket seals completely all around during reassembly of the condensation reservoir.



During installation pay attention to the correct position of the clamp bars. These have to be in a vertical position.



Always replace the gaskets of the removed parts during maintenance.

Put the boiler back into operation and carry out a flue gas analysis (see page 33).



Always put back the cover after (maintenance) work and secure it with screws A, B, C and D.

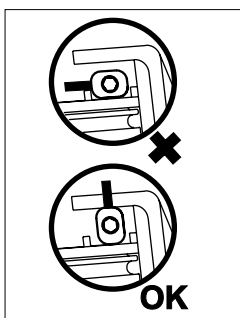

Figure 19

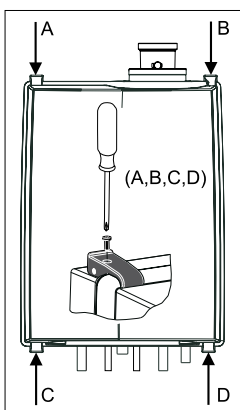

Figure 20

13.3 Maintenance frequency

ATAG Heating UK Ltd advises an annual inspection, with a full strip down service every 4 years, depending on the operational hours listed in the warranty conditions.

13.4 Warranty

For the warranty conditions we refer to the Warranty Card that is supplied with the boiler.

14 Error message

A detected failure is indicated on the display in blocking or error messages.



- Blocking code with spanner symbol
Error is temporary and will cancel itself or will lock the boiler after several attempts (error)



- Error code with bell symbol
Error means a lock on the boiler and can only be remedied by a reset and/or intervention by a service technician.

- C 20 Flow sensor error (e.g. open, short circuit, outside of range)
- C 40 Return sensor error (e.g. open, short circuit, outside of range)
- C 78 Water pressure outside of range or not connected or if water pressure is OK:
Pump failure
- C1 05 Venting program active
- C1 10 Safety temperature exceeded
- C1 11 Maximum temperature exceeded
- C1 17 Pressure too high (> 3 bar) or pump pressure increase too high
- C1 18 Pressure too low (<0.7 bar) or pump pressure increase too low (no pump detection)
- C1 29 Fan error (fan does not start up)
- C1 33 no flame after 5 ignition attempts
- C1 51 fan error (speed control is not achieved or is outside of range)
- C1 54 flow increases to fast ΔT to large, return > supply

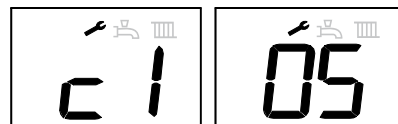

Example of display of error message

15 Technical specifications

Boiler type	ATAG A-Series					
	A203C	Combi			Solo	
		A325C	A325ECX	A200S	A320S	
Input Hs CH	kW	20	32	32	20	32
Q _n Input Hi CH	kW	18	28,8	28,8	18	28,8
Q _{nw} Input Hi DHW	kW	23,4	34,2	34,2		
Efficiency DHW, year	%	83,2	85,9	95,1		
Efficiency class according BED		★★★★	★★★★	★★★★	★★★★	★★★★
Efficiency according EN677 (36/30°C part load, Hi)	%	109,2	109,7	109,7	109,2	109,7
Efficiency according EN677 (80/60°C full load, Hi)	%	97,9	97,9	97,9	97,9	97,9
Modulation range CH (capacity 80/60°C)	kW	4,4 - 17,6	6,1 - 28,2	6,1 - 28,7	4,4 - 17,6	6,1 - 28,2
Modulation range CH (capacity 50/30°C)	kW	4,9 - 19,3	6,8 - 30,9	6,8 - 30,9	4,9 - 19,3	6,8 - 30,9
Nox class EN483		5				
CO ₂ /O ₂	%	9 / 4,7				
Temperature class for PP flue		T100				
Appliance type		B ₂₃ B ₃₃ C ₁₃ C ₃₃ C ₄₃ C ₅₃ C ₆₃ C ₈₃ C ₉₃				
Flue gas temp. CH (80/60°C on full load)	°C	68	68	58,7	68	68
Flue gas temp. CH (50/30°C on low load)	°C	31	31	30,5	31	31
Categories		II2H3P				
Gas consumption G20 CH (DHW) (at 1013 mbar/15°C)	m ³ /h	1,91 (2,48)	3,05 (3,62)	3,05 (3,62)	1,91	3,05
Electr. power consumption max.	W	114	117	117	114	117
Electr. power consumption part load	W	86	89	89	86	89
Electr. power consumption stand by	W	3,7	3,7	3,7	3,7	3,7
Current	V/Hz	230 +10 %-15 % / 50Hz				
Degree of protection acc. EN 60529		IPX4D (IPX0D for B ₂₃ & B ₃₃)				
Weight (empty)	kg	37,5	42,5	45,5	34,5	39
Width	mm	500	500	500	500	500
Height	mm	650	870	870	650	870
Depth	mm	395	395	395	395	395
Water content CH	l	3,3	4,8	4,8	3,3	4,8
Water content DHW	l	0,5	0,7	0,7		
Overrun time pump CH	sec			60		
Overrun time pump DHW	sec	20	20	20		
Content expansion vessel	l	8	12	12	8	12
Pre-charge pressure exp. Vessel	bar	0,8	1	1	0,8	1
P _{MS} Water pressure CH min./max.	bar			1/3		
P _{MW} Water pressure DHW min./max.	bar		1/8			
Flow temperature max.	°C			85		
Pump type	UP	15-50	15-60	15-60	15-50	15-60
available	kPa	28	20	20	28	20
DHW flow (at ΔT = 35°C)	l/min	9,3	14,3	15,0		
DHW flow (at ΔT = 28°C)	l/min	11,6	17,9	18,8		
Max. DHW temperature (T _{in} =10°C)	°C	60	60	60		
CE product identification number(PIN)		0063BT3195				

16 Parts of the boiler

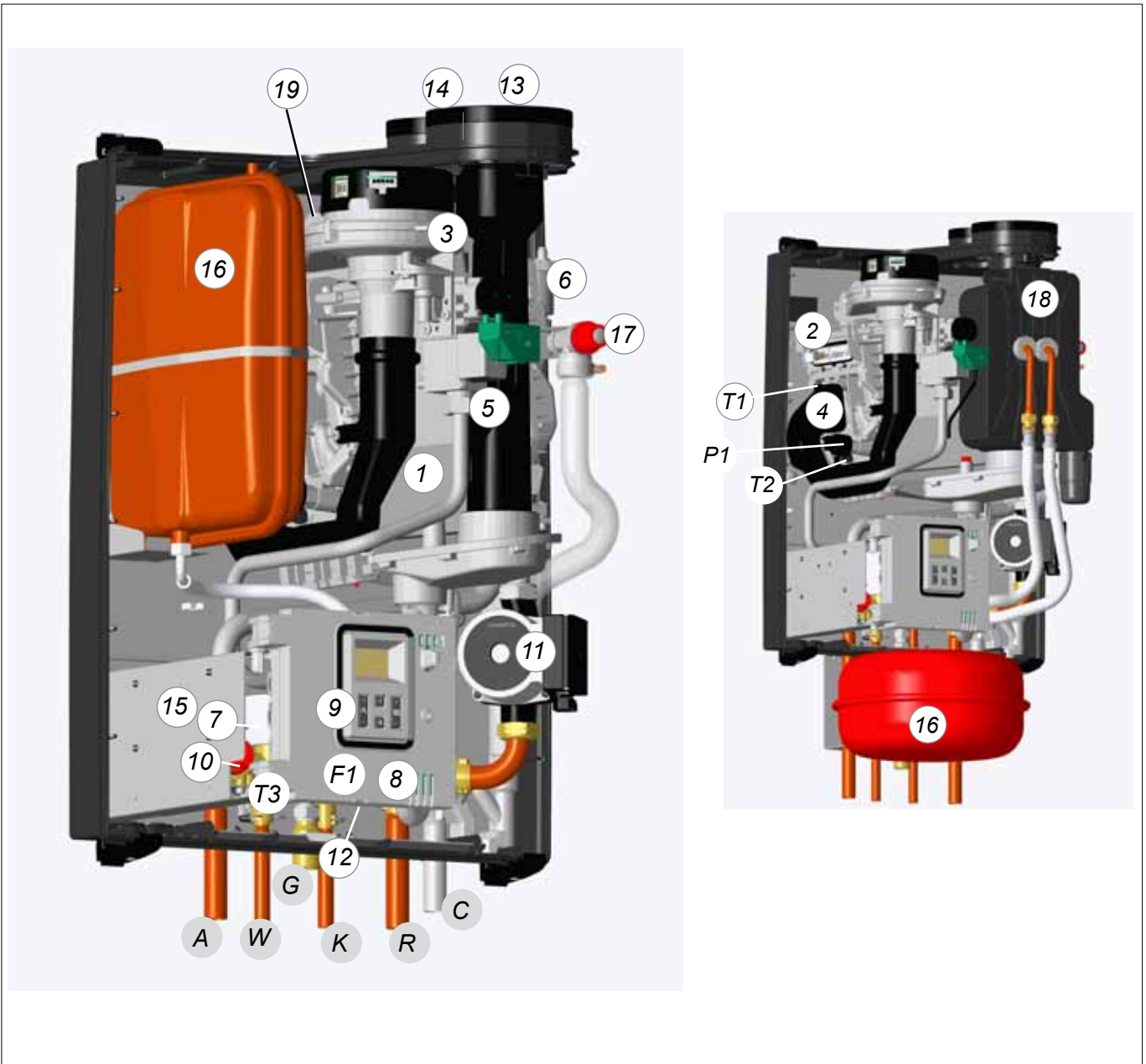

ATAG A

figure 21

1 Heat exchanger	9 Control panel	17 Safety valve
2 Ignition unit	10 Three-way valve	18 DHW Economiser
3 Fan unit	11 Circulation pump	19 Flue non return valve
4 Air supply damper	12 Dosing valve	
5 Gas block	13 Flue gas exhaust	
6 Automatic de-aerator	14 Combustion air supply	
7 DHW plate heat exchanger	15 Information plate	
8 Control Management System	16 Expansion vessel	

T1 Flow sensor
T2 Return sensor
T3 Hot water sensor
F1 DHW Flow sensor
P1 Water pressure sensor
G Gas pipe

A Flow pipe CH
R Return pipe CH
C Condensation pipe
K Cold water pipe
W Hot water pipe

CE DECLARATION OF CONFORMITY

Hereby declares ATAG Verwarming Nederland BV that,

the condensing boiler types: ATAG

A203C	A200S
A325C	A320S
A325ECX	

are in conformity with the provisions of the following EC Directives, including all amendments, and with national legislation implementing these directives:

<u>Directive</u>		<u>Used standards</u>
Gas Appliance Directive	2009/142/EC (ex.90/396/EEG)	EN483: 1999,A2 ;2001-C1 ;2006,A4 ;2007 EN50165: 1997
Efficiency Directive	92/42/EEC	EN677: 1998
Low Voltage Directive	2006/95/EG	EN50165: 1997 EN60335-1: 1994
EMC Directive	2004/108//EG	EN61000-3-2: 2000,A1 ;2001,A2 ;2005 EN61000-3-3: 1995,2006 EN55014-1: 1993;A1;2001,A2;2002 EN50165: 1997,A1;2001 EN55014-2: 1997,A1;2001

Report numbers

	GAD	ED	LVD	EMC D
ATAG A	178195	178195	178195-LVD-1	178195-EMC-1

and that the products are in conformity with EC type-examination certificate number E0430, as stated by KIWA-Gastec Certification BV, Apeldoorn, The Netherlands.

Date : 3 january 2011

Signature :



Full name : Drs. C. Berlo
CEO



Adres: Galileistraat 27, 7131 PE Lichtenvoorde • Postadres: Postbus 105, 7130 AC Lichtenvoorde
Telefoon: +31(0) 544 391777, Fax: +31(0) 544 391703
E-mail: info@atagverwarming.com Internet: http://www.atagverwarming.nl

Certificate



UK APPROVAL
Certificate Number: 0911701

Date Issued: 12th November 2009
 Date Expired: 12th November 2014

Description: 'A' Range of wall mounted sealed circuit and combination boilers.

Product Designation:
A200S 0V, A200S, A320S, A203C, A325C and A325EC

This is to certify that the above range of products manufactured / supplied by

ATAG VERWARMING NEDERLAND BV

1. Has been tested and found to comply with the requirements of the Water Supply (Water Fittings) Regulations 1999 for England and Wales, the Water Byelaws 2000, Scotland and the Water Regulations Northern Ireland.

This certificate must be read in conjunction with the acceptance letter for this product.

This approval is intended for compliance with the above Regulations and must not be considered equivalent to the product certification provided by Kiwa N.V

To comply with the Regulations and Byelaws all products require the correct installation. Details of the installation requirements (IRN's) can be obtained from the acceptance letter supplied with this certificate.

Applicable IRN's for this certificate – R001, R140, R360

Authorised Signature
 Kiwa Quality Services Ltd

Kiwa Quality Services Ltd
 The Innovation Centre
 Victoria Park
 Festival Drive
 Ebbw Vale
 Gwent
 NP23 8XA

Tel 00 44 (0) 1495 356795
 Fax 00 44 (0) 1495 350020
 E-mail: info@kiwa.co.uk
 Web: www.kiwa.co

Certificate Issued To –

ATAG VERWARMING NEDERLAND BV
 Galliestraat 27
 7131PE Lichtenvoorde
 Netherlands



GAS BOILER SYSTEM COMMISSIONING CHECKLIST

This Commissioning Checklist is to be completed in full by the competent person who commissioned the boiler as a means of demonstrating compliance with the appropriate Building Regulations and then handed to the customer to keep for future reference.

Failure to install and commission according to the manufacturer's instructions and complete this Benchmark Commissioning Checklist will invalidate the warranty. This does not affect the customer's statutory rights.

Customer Name _____ Telephone Number _____

Address _____

Boiler Make and Model _____

Boiler Serial Number _____

Commissioned by (print name) _____ Gas Safe Register Number _____

Company Name _____ Telephone Number _____

Company Address _____

Commissioning Date _____

To be completed by the customer on receipt of a Building Regulations Compliance Certificate*:

Building Regulations Notification Number (if applicable) _____

CONTROLS Tick the appropriate boxes

Time and Temperature Control to Heating	Room Thermostat and Programmer/Timer <input type="checkbox"/>	Programmable Room Thermostat <input type="checkbox"/>	Load/Weather Compensation <input type="checkbox"/>	Optimum Start Control <input type="checkbox"/>
Time and Temperature Control to Hot Water	Cylinder Thermostat and Programmer/Timer <input type="checkbox"/>			Combination Boiler <input type="checkbox"/>
Heating Zone Valves	Fitted <input type="checkbox"/>			Not Required <input type="checkbox"/>
Hot Water Zone Valves	Fitted <input type="checkbox"/>			Not Required <input type="checkbox"/>
Thermostatic Radiator Valves	Fitted <input type="checkbox"/>			Not Required <input type="checkbox"/>
Automatic Bypass to System	Fitted <input type="checkbox"/>			Not Required <input type="checkbox"/>
Boiler Interlock				Provided <input type="checkbox"/>

ALL SYSTEMS

The system has been flushed and cleaned in accordance with BS7598 and boiler manufacturer's instructions Yes

What system cleaner was used? _____

What inhibitor was used? _____ Quantity _____ litres

CENTRAL HEATING MODE Measure and Record:

Gas Rate _____ m³/hr OR _____ ft³/hr

Burner Operating Pressure (if applicable) _____ mbar OR Gas Inlet Pressure _____ mbar

Central Heating Flow Temperature _____ °C

Central Heating Return Temperature _____ °C

COMBINATION BOILERS ONLY

Is the installation in a hard water area (above 200ppm)? Yes No

If yes, and if required by the manufacturer, has a water scale reducer been fitted? Yes No

What type of scale reducer has been fitted? _____

DOMESTIC HOT WATER MODE Measure and Record:

Gas Rate _____ m³/hr OR _____ ft³/hr

Burner Operating Pressure (at maximum rate) _____ mbar OR Gas Inlet Pressure (at maximum rate) _____ mbar

Cold Water Inlet Temperature _____ °C

Hot water has been checked at all outlets Yes Temperature _____ °C

Water Flow Rate _____ l/min

CONDENSING BOILERS ONLY

The condensate drain has been installed in accordance with the manufacturer's instructions and/or BS5546/BS6798 Yes

If the condensate pipe terminates externally has the pipe diameter been increased and weatherproof insulation fitted? Yes

ALL INSTALLATIONS

If required by the manufacturer, record the following CO₂ _____ % OR CO _____ ppm OR CO/CO₂ Ratio _____

The heating and hot water system complies with the appropriate Building Regulations Yes

The boiler and associated products have been installed and commissioned in accordance with the manufacturer's instructions Yes

The operation of the boiler and system controls have been demonstrated to and understood by the customer Yes

The manufacturer's literature, including Benchmark Checklist and Service Record, has been explained and left with the customer Yes

Commissioning Engineer's Signature _____

Customer's Signature _____

(To confirm satisfactory demonstration and receipt of manufacturer's literature)

*All installations in England and Wales must be notified to Local Authority Building Control (LABC) either directly or through a Competent Persons Scheme. A Building Regulations Compliance Certificate will then be issued to the customer.



Service Record

It is recommended that your heating system is serviced regularly and that the appropriate Service Interval Record is completed.

Service Provider

Before completing the appropriate Service Record below, please ensure you have carried out the service as described in the manufacturer's instructions.

Always use the manufacturer's specified spare part when replacing controls.

Service 1

Date: _____

Engineer Name: _____

Company Name: _____

Telephone No. _____

Gas Safe Register No. _____

Comments: _____

Signature: _____

Service 2

Date: _____

Engineer Name: _____

Company Name: _____

Telephone No. _____

Gas Safe Register No. _____

Comments: _____

Signature: _____

Service 3

Date: _____

Engineer Name: _____

Company Name: _____

Telephone No. _____

Gas Safe Register No. _____

Comments: _____

Signature: _____

Service 4

Date: _____

Engineer Name: _____

Company Name: _____

Telephone No. _____

Gas Safe Register No. _____

Comments: _____

Signature: _____

Service 5

Date: _____

Engineer Name: _____

Company Name: _____

Telephone No. _____

Gas Safe Register No. _____

Comments: _____

Signature: _____

Service 6

Date: _____

Engineer Name: _____

Company Name: _____

Telephone No. _____

Operative ID No. _____

Comments: _____

Signature: _____

Service 7

Date: _____

Engineer Name: _____

Company Name: _____

Telephone No. _____

Gas Safe Register No. _____

Comments: _____

Signature: _____

Service 8

Date: _____

Engineer Name: _____

Company Name: _____

Telephone No. _____

Gas Safe Register No. _____

Comments: _____

Signature: _____

Service 9

Date: _____

Engineer Name: _____

Company Name: _____

Telephone No. _____

Gas Safe Register No. _____

Comments: _____

Signature: _____

Service 10

Date: _____

Engineer Name: _____

Company Name: _____

Telephone No. _____

Gas Safe Register No. _____

Comments: _____

Signature: _____



kiwa
approved
product



UK WATER SUPPLY
REGULATIONS



recommended

energysavingtrust.org.uk
Certification Mark



ATAG Heating UK Ltd. • Unit 3 • Beaver Trade Park • Quarry Lane Chichester West Sussex PO19 8NY
Phone: 01243 815 770 • Fax 01243 839 596 • E-mail: info@atagheating.co.uk • Internet: www.atagheating.co.uk

This renewed publication cancels all previous installation instructions. The company reserves the right to change the specifications and dimensions without prior notice.

E. & O. F.