

This manual must be kept with the appliance

January 2011

Part No E104

RSC 150 / RSC 190

Permanent Pilot, Auto Ignition

Installation Guide, Operation & Service Manual



Working towards
a cleaner future





Reproduction of any information in this publication by any method is not permitted unless prior written approval has been obtained from Andrews Water Heaters.

Andrews Storage Water Heaters have been designed and manufactured to comply with current International standards of safety. In the interests of the health and safety of personnel and the continued safe, reliable operation of the equipment, safe working practices must be employed at all times. The attention of U.K. users is drawn to their responsibilities under the Health and Safety Regulations 1993.

All installation and service on the Andrews Water Heater must be carried out by properly qualified personnel, and therefore no liability can be accepted for any damage or malfunction caused as a result of intervention by unauthorised personnel.

The Andrews Water Heaters policy is one of continuous product improvement, and therefore the information in this manual, whilst completely up to date at the time of publication, may be subject to revision without prior notice.

Further information and assistance can be obtained from:

Andrews Water Heaters

Wood Lane, Erdington, Birmingham B24 9QP

Tel: 0845 070 1055 Fax: 0845 070 1059

Sales: 0845 070 1056

Technical: 0845 070 1057

Service: 0845 070 1058

Email: andrews@andrews-waterheaters.co.uk

www.andrewswaterheaters.co.uk

**THE ANDREWS WATER HEATERS COVERED IN THIS MANUAL
ARE FOR USE WITH NATURAL GAS ONLY**

SECTION 1	GENERAL AND SAFETY INFORMATION	
	General Information	2
	British Standards and Codes of Practice	2
	Health and Safety Regulations 1993	3
	Effectiveness in Combating Legionellae	3
SECTION 2	TECHNICAL DATA	4
SECTION 3	INSTALLATION	
	Location	5
	Flue Systems	5
	Air Supply and Ventilation	6
	Electrical Supply (Auto Ignition)	8
	Water Connections	9
	Water Quality & Treatment	9
	Hydrojet Systems	9
	Vented Systems	10
	Unvented Systems	11
	Gas Connections	14
SECTION 4	COMMISSIONING	
	To Light the Burner	15
	To Shut Off the Burner	15
	To Check Main Burner Pressure	15
	To Light the Burner Auto Ignition	16
	To Shut Off the Burner Auto Ignition	16
	To Check Main Burner Pressure Auto Ignition	16
SECTION 5	OPERATION	
	Operating Sequence	17
	ECO (Energy Cut-Off)	17
	Auto Ignition	17
SECTION 6	SERVICING	
	Burner Assembly	18
	Gas Control Valve	18
	Flueway	19
	Magnesium Anode	19
	Descaling Information	19
SECTION 7	FAULT FINDING	20
SECTION 8	PARTS LISTS AND ILLUSTRATIONS	22

GENERAL INFORMATION

The Andrews Water Heater has been designed for use with NATURAL GAS only and is manufactured to give an efficient, reliable and long service life.

To ensure the continued, trouble-free operation of your heater at maximum efficiency, it is essential that correct installation, commissioning, operation and service procedures are carried out strictly in accordance with the instructions given in this manual. By law, installation and commissioning of the heater must be carried out by properly qualified personnel.

The heater(s) must be installed in accordance with the following requirements;
The current GAS SAFETY (INSTALLATION AND USE) REGULATIONS
The current BUILDING REGULATIONS
The WATER SUPPLY (WATER FITTINGS) REGULATIONS 1999

Additionally, installation should be performed in accordance with all relevant requirements of the Gas Supplier, Local Authority and recommendations of the British Standards and Codes of Practice detailed below.

BRITISH STANDARDS AND CODES OF PRACTICE

STANDARD RANGE

BS 6700: 1997	Specification for design, installation, testing and maintenance of services supplying water for domestic use within buildings and their curtilages. This standard supersedes the following British Standards and Codes of Practice: CP99, CP310, CP324, 202, CP342 Part 2, Centralised Hot Water Supply.
BS 5440:1990	Installation of flues and ventilation for gas appliances of rated output not exceeding 60kW.
BS 6644	Installation of gas fired hot water boilers of rated inputs between 60kW and 2MW.
BS 5546:1990	Installation of gas hot water supplies for domestic purposes.
BS 6891	Installation of low pressure gas pipework of up to 28mm in domestic premises.
BS 7206:1990	Specification for unvented hot water storage units and packages.
I/M2	Purging procedures for industrial and commercial gas installations.
I/M11	Flues for commercial and industrial gas fired boilers and air heaters.
I/M16	Notes on installation of gas pipework (excluding 25mm and below).
BS 6798	Installation of gas fired hot water boilers of rated input not exceeding 60kW.

NOTE: Consideration should be given to amendments or updates to the above standards.

It is the duty of manufacturers and suppliers of products for use at work to ensure, so far as is practicable, that such products are safe and without risk to health when properly used and to make available to users, adequate information about their safe and proper operation.

Andrews Water Heaters should only be used in the manner and purpose for which they were intended and in accordance with the instructions in this manual. Although the heaters have been manufactured with paramount consideration to safety, the basic safety precautions highlighted in this manual must be observed by the user.

It is imperative that all users of the heater must be provided with all the information and instruction necessary to ensure correct and safe operation.

Water systems in buildings have been associated with outbreaks of Legionnaires' Disease, particularly in health care facilities where occupants are significantly more susceptible to infection.

In recognition of the risks in hospitals, a Code of Practice for the Control of Legionellae in Health Care premises has been issued by the Department of Health (1991). Codes of Practice applicable to other premises have been published by other organisations, principally the Health and Safety Executive (HS)(G70) and the Chartered Institute of Building Services Engineers (CIBSE, TM13).

All Codes of Practice draw attention to the design and operation of water systems with reference to avoidance of factors that favour colonisation by Legionellae bacteria. These factors include stagnation, lukewarm conditions (20°C to 45°C) and the accumulation of debris, scale and corrosion in the base of tanks and calorifiers.

Andrews Water Heaters has commissioned an independent evaluation of their products to investigate their resistance to build-up of legionellae bacteria.

Experiments were conducted to determine whether, following a substantial challenge by legionellae pneumophila, after overnight and stagnation conditions, the system was rendered free from viable recoverable legionellae. It was found that at 61°C, following a challenge of approximately 10⁷ organisms per litre, within one hour, more than 99.999% of organisms had been killed. After a subsequent stagnation period, sampling did not reveal any residual contamination. The design of the base of the water heater precludes legionellae colonisation, even after build-up of debris. The burner positioning ensures that the water at the bottom of the heater reaches the same, or higher temperature as in the rest of the heater.

Based on data obtained through experiment, the Andrews Water Heater can be described as legionellae resistant as it is considered unlikely that, at the temperature tested, the organism would colonise the water heater and present a possible health risk.

HEALTH AND SAFETY REGULATIONS 1993

EFFECTIVENESS IN COMBATING LEGIONELLAE

DIMENSIONS AND CLEARANCES

Fig 1. Appliance Dimensions Including Standard Flue Run Dimensions

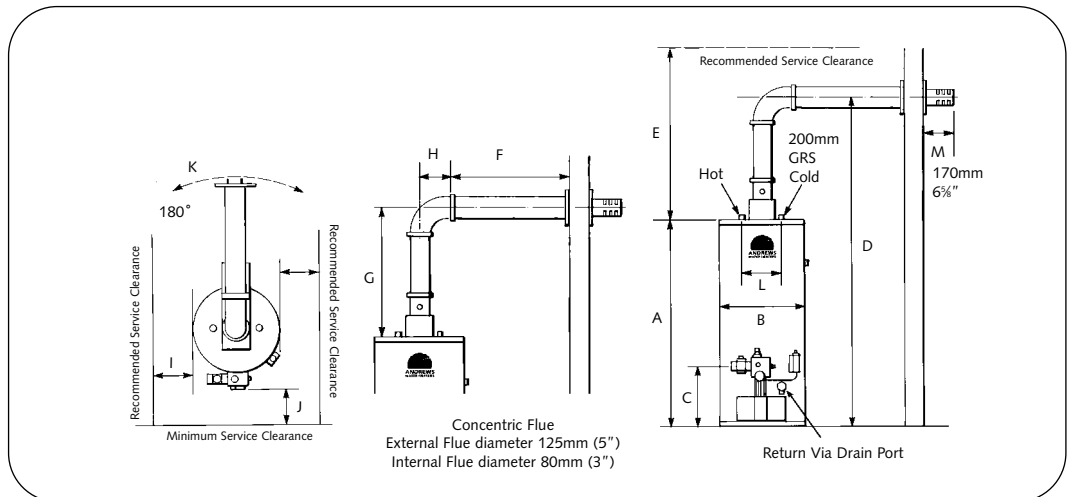

ANDREWS MODEL NO.	RSC 150		RSC 190	
	SI Metric	Imperial	SI Metric	Imperial
A Height of Heater	1264 mm	49¾ in	1492 mm	58¾ in
B Diameter	508 mm	20 in	508 mm	20 in
C Gas Connection	378 mm	14¾ in	378 mm	14¾ in
D Height to Centre of Flue	2118 mm	85 in	2398 mm	94 in
E Service Clearance	1226 mm	48 in	1226 mm	48 in
F Standard Flue Run	750 mm	29½ in	750 mm	29½ in
G Height to Flue Centre	854 mm	33½ in	854 mm	33½ in
H Standard 90° Elbow	194 mm	7¾ in	194 mm	7¾ in
I Service Clearance	305 mm	12 in	305 mm	12 in
J Service Clearance (Front)	610 mm	24 in	610 mm	24 in
K	We recommend that the flue outlet can be installed in any configuration through 180° as long as proper service clearances are observed.			
L Water Connection GRS	200mm	7¾ in	200mm	7¾ in
M Flue Terminal	170mm	6¾ in	170mm	6¾ in
Storage Capacity	150 litres	33 gallons	190 litres	42 gallons
Recovery through 44°C/80°F	159 l/hr	35 gph	181 l/hr	40 gph
Recovery through 56°C/100°F	127 l/hr	28 gph	145 l/hr	32 gph
Heat Input	9.5 kW	32,414 Btu/hr	10.5 kW	35,826 Btu/hr
Heat Output	8.2 kW	27,978 Btu/hr	9.4 kW	32,073 Btu/hr
Gas Flow Rate	0.88 m³/hr	31.32 ft³/hr	0.98 m³/hr	34.62 ft³/hr
Gas family	I ₂ H Natural		I ₂ H Natural	
Flue Gas Temp Approx	180°C		180°C	
Flue Gas Volume	16m³/H		16m³/H	
Inlet & Flow connections	Rp ¾	¾ BSP	Rp ¾	¾ BSP
Return connections	Rp ¾	¾ BSP	Rp ¾	¾ BSP
Gas Connection	Rp ½	½ BSP	Rp ½	½ BSP
Maximum Working Pressure	10 bar	150 p.s.i.	10 bar	150 p.s.i.
Maximum Test Pressure	20.6 bar	300 p.s.i.	20.6 bar	300 p.s.i.
Burner Pressure	10.0 mBar	4.0 wg.	10.0 mBar	4.0 wg.
Injector Diameter	2.87 mm	0.113 ins	3.05 mm	0.120 ins
Flue Connection	80/125		80/125	
Weight Empty	66 kg	145 lbs	74 kg	163 lbs
Weight Full	216 kg	475 lbs	264 kg	583 lbs
Shipping Weight	73 kg	162 lbs	82 kg	181 lbs
Shipping dimensions carton	1499 x 635 x 711 mm 59 x 25 x 28 in		1727 x 635 x 711 mm 68 x 25 x 28 in	

Maximum Test Pressure 20.6 bar/300 psi

THE LAW REQUIRES THAT INSTALLATION IS CARRIED OUT BY A PROPERLY QUALIFIED PERSON

Install in accordance with current British Standard Code of Practice 342 part 2 and British Standards 5440, 5546, 6644, 6700, 6798 and 6891.

The location chosen for the heater must permit the provision of a satisfactory flue and an adequate air supply.

A clearance of 300mm (12in) should be left around the heater for fitting and servicing purposes and 762mm (30in) above the heater for removal of the flue baffle. The above clearances are recommended for ease of servicing. They can be reduced if necessary but a clearance of 300mm (12 in) must be left in front of heater for access to the burner and controls. The flue baffle clearance should also be maintained if possible to avoid servicing problems.

The floor on which the heater is installed must be flat, level and of sufficient strength to withstand the weight of the heater when filled with water, and should satisfy the requirements of the Local Authority & Building Regulations.

Any combustible material adjacent to the heater must be so placed or shielded as to ensure that its temperature does not exceed 66°C (150°F).

Detailed recommendations for flueing are given in British Gas Booklet IM/11 and BS 5440 part 1. The following notes are intended to give general guidance:

- A horizontal or vertical flue kit is supplied with each heater. Flue fitting instructions on page 6.
- Location. The siting of the flue terminal is not critical with respect to the performance of the unit. However, areas where the discharge of combustion products would cause a nuisance should be avoided. In accessible positions a suitable guard should be provided. (see page 6).
- Route. The route of the flue is not critical, with three installation options available. See below for permissible flue lengths. Where installation options 2 or 3 are used we recommend that the flue outlet can be installed in any configuration through 180° as long as proper service clearances are observed see fig.1 page 4.

LOCATION

FLUE SYSTEM

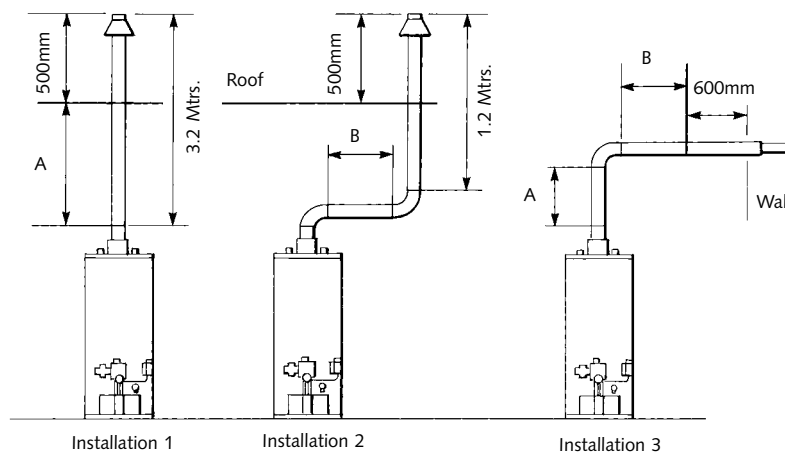

Fig 2.
Typical Flue Installations and Permissible Flue Lengths

Model RSC150

Flueing Option	Installation 1	Installation 2	Installation 3
Type of flueing	C31	C31	C11
Flue restrictor	Ø 45mm	Ø 50mm	Ø 60mm
A	≤ 2.0	-	≥ 0.5m and ≤ 1.0m
B	-	≤ 1.0m	≤ 1.0m

Model RSC190

Flueing Option	Installation 1	Installation 2	Installation 3
Type of flueing	C31	C31	C11
Flue restrictor	Ø 48mm	Ø 55mm	no restrictor required
A	≤ 2.0	-	≥ 0.5m and ≤ 1.0m
B	-	≤ 1.0m	≤ 1.0m

RSC150 & RSC190 Flue Fitting Instructions

1. Fit heater adaptor D1 to heater ensuring correct location on primary flue spigot from heater. (Use 4 self tapping screws provided).
2. Fit flue restrictor ring D7 into heater adaptor D1 The correct size of restrictor for each heater model and installation is shown on page 5.
3. Fit flue section D2 into heater adaptor D1.
4. Fit elbow D4 into flue section D2 for horizontal flue runs.
5. Determine correct position of flue outlet and fit outer wall plate and inner wall plate. Fit flue outlet guard if required. (Fixings not supplied).
6. Fit horizontal terminal D3 or make up lengths of flue required (see page 5) into elbow D4. Each joint must be secured with a sealed clamp D6.
7. For vertical installations fit flue lengths required (see page 5) into heater adaptor D1.
8. Determine correct position of flue terminal and fit either D8 or D9 roof plates.
9. Fit D5 vertical terminal through roof plate into vertical flue pipe.
10. Fit D6 sealed clamps on all joints.
11. On all installations the lengths of flue pipes may be cut to obtain correct length of flue route required.
12. See parts list on page 20 for part numbers and description of flue available.

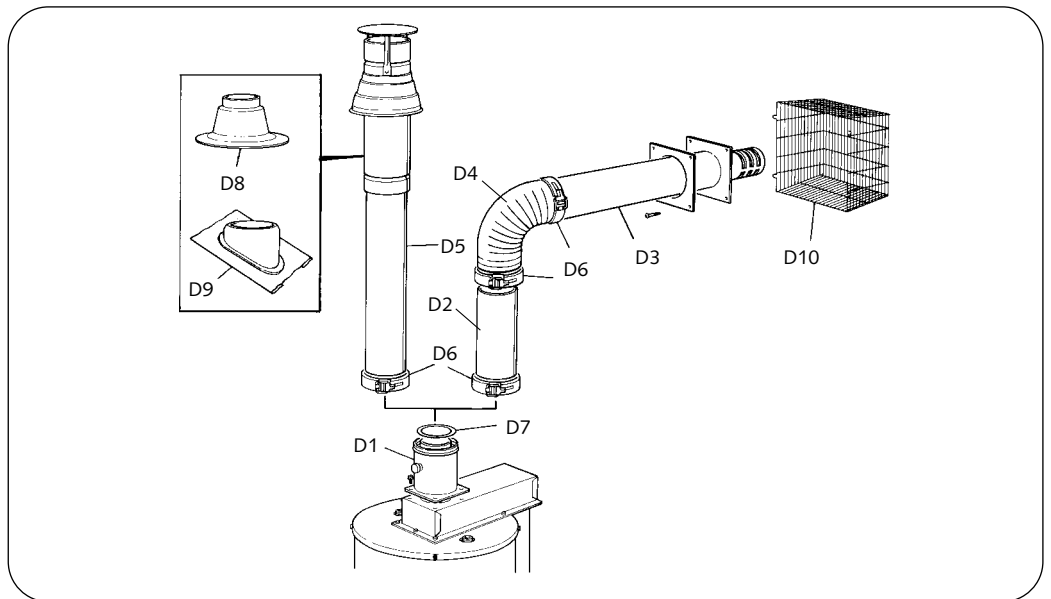

Components Supplied In Flue Kits

AIR SUPPLY AND VENTILATION

The following notes are intended to give general guidance:
Where the heater is to be installed in a room **NO VENTS ARE REQUIRED**.

Where the heater is to be installed in a compartment, permanent air vents are required in the compartment at high and low level. These air vents must either communicate with a room or internal space or be direct to outside air.

The minimum effective areas of the permanent air vents required in the compartment are as follows:

Position of Air Vents	Air Vents Areas	
	Air from room or internal space	Air direct from outside
High Level	10cm ² per kW	5cm ² per kW
Low Level	10cm ² per kW	5cm ² per kW
In a Room or Internal Space	No requirement for ventilation	

Note: - Both air vents must communicate with the same room or internal space or must both be on the same wall to outside air.

Air vents should have negligible resistance and must not be sited in any position where they are likely to be easily blocked or flooded or in any position adjacent to an extraction system which is carrying flammable vapour.

Consideration must be given to the position of the high level ventilation opening. A high level vent must not be sited within 300mm measured vertically, of the flue terminal

Grilles or louvers should be so designed that high velocity air streams do not occur within the space housing the heater(s).

IMPORTANT:

The vapours given off by halogen based compounds can, if drawn into the combustion air, cause corrosion of the Storage Vessel and premature failure of the thermocouple.

If water heaters are to be installed, in locations where halogens are likely to be present they should be isolated from such compounds and ventilated from and to outside, uncontaminated atmosphere.

Some of the vulnerable areas are listed below -

- (i) Hairdressing salons and adjoining rooms and basements.
- (ii) Establishments where dry cleaning solutions are used or stored.
- (iii) De-greasing plants using hydrocarbon solvents.
- (iv) Premises where refrigerant gases are used or stored.

ELECTRICAL SUPPLY - AUTO IGNITION UNITS

External wiring to the water heater(s) must be installed in accordance with current I.E.E. Regulations for the wiring of buildings and to any Local Regulations that may apply.

The Auto Ignition Heater is designed to operate from a 220/240V, 1Phase supply. The fuse rating is 5 amps.

The method of connection to the mains electricity supply should facilitate complete electrical isolation of the appliance, preferably by use of an unswitched shuttered socket outlet in conjunction with a fused three pin plug, both complying with the requirements of BS 1363.

Alternatively, a fused double pole switch or fused spur box serving only the heater may be used.

The point of connection to the mains electricity supply should be readily accessible and adjacent to the appliance.

Connect the electrical supply to the main control panel terminal block via the cable glands in the base of the control panel. Mains input cable should be 0.75mm², 3 core, and should be connected to the mains supply as detailed above.

It is recommended that screen cable is used where the volt-free contacts are to be connected from an external supply. This will eliminate the risk of possible interference from nearby high voltage cables.

Auto Ignition

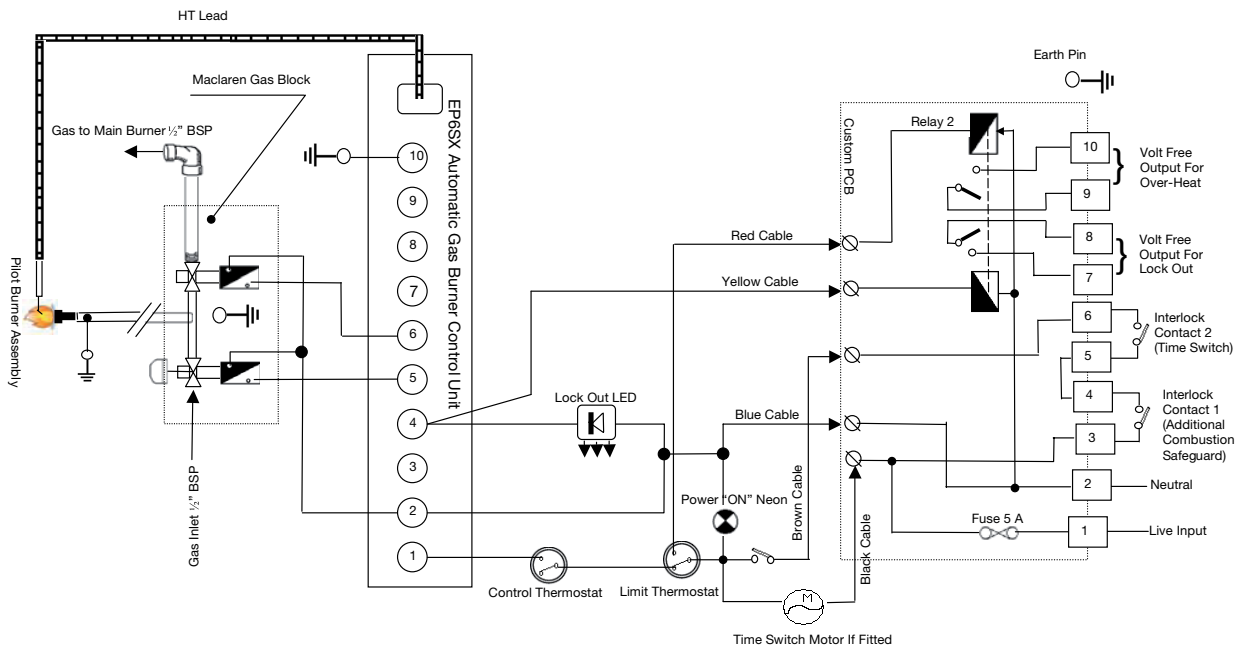

NOTE:
The Interlock contact terminals 3&4 – 5&6 must be linked if no device is fitted

WATER CONNECTIONS
WATER QUALITY AND TREATMENT

To ensure long life and efficient, reliable performance from Andrews water heaters it is essential that the water heater is installed and serviced in accordance with the manufacturers instructions.

Each water heater is fitted with one or more magnesium anode(s) which protect the tank from corrosion caused by electrolytic action within water systems. The magnesium anodes are sacrificial and as such they erode as they offer protection. Once the anode has eroded to less than 50% of its original diameter it may not offer sufficient protection. The anodes should be inspected on an annual basis and replaced as necessary. The frequency of which the anode needs replacing can vary and water quality can have a major influence on this.

Andrews offer Correx™ UP powered anodes as an alternative to the traditional magnesium anodes. Correx™ UP anodes are made from titanium and are non sacrificial, therefore they do not have a requirement for maintenance or replacement. However, the potentiostat, which regulates the protective current supplied to the Correx™ UP anode, has an indicator light which shows green when the anode is functioning correctly and red if a malfunction occurs.

Correx™ UP anodes are available as an optional extra on all models of Andrews storage water heaters and tanks.

In hard water areas scale formation can occur in hot water systems and water heaters and the higher the temperature of operation and the higher the volume of water used the more problematic this scale build up can be. Water treatment is normally recommended when the hardness reaches 100-150 ppm (7-10 degrees Clark) and above - a number of water treatment devices are available. When specifying or installing Andrews water heaters in hard water areas we would recommend that a specialist in this area of operation is consulted.

Contact Andrews Water Heaters for further information.

How the system works

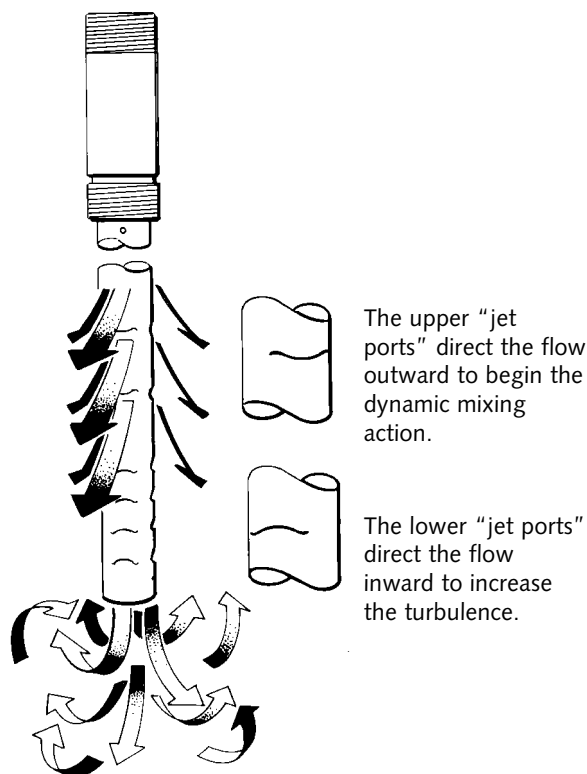

HYDROJET SYSTEM

The heater is fitted with the Hydrojet Total Performance System incorporated in the cold inlet dip tube. The tube is designed to increase turbulence and reduce sediment build up, reduce thermal stacking and increase delivery.

WATER CONNECTIONS VENTED SYSTEMS

The water heater must be supplied from a cold water feed cistern and the hot water supply pipe must be fitted with an open vent pipe in accordance with BS 5546. Local regulations and bye-laws must be observed when installing the system but typical water service layouts are shown in Fig. 3.

The cold water feed cistern must have an actual capacity greater than the hourly recovery rate of the heater or heaters to which it is fitted, the minimum actual capacity allowed for a feed cistern is 227 litres (50 gal).

The actual cistern capacity is the capacity to the normal water line of the cistern. All cisterns used should be to the relevant British Standard and the distance from the normal water line to the top of the cistern should be as laid down by the water authorities.

The cold water inlet and hot water outlet are identified on top of the heater. Connect the cold water feed and hot water outlet to these nipples with union adaptors for ease of servicing.

CAUTION - DO NOT APPLY HEAT TO THESE NIPPLES IF MAKING CAPILLARY SOLDERED JOINTS AS THEY ARE FITTED WITH PLASTIC INSERTS. MAKE THE CAPILLARY JOINTS TO THE PIPES BEFORE CONNECTING TO THE HEATER. A DRAIN COCK IS SUPPLIED WITH THE HEATER AND THIS SHOULD BE FITTED TO THE APPROPRIATE BOSS AS SHOWN ON THE DRAWING.

After installation of the water system open the main water supply valve, flush the system and fill the heater. Open the hot taps to allow air to escape from the system. When the system is free of air, close the taps and check for leaks at the control thermostat, drain cock and pipe connections at the top of the heater.

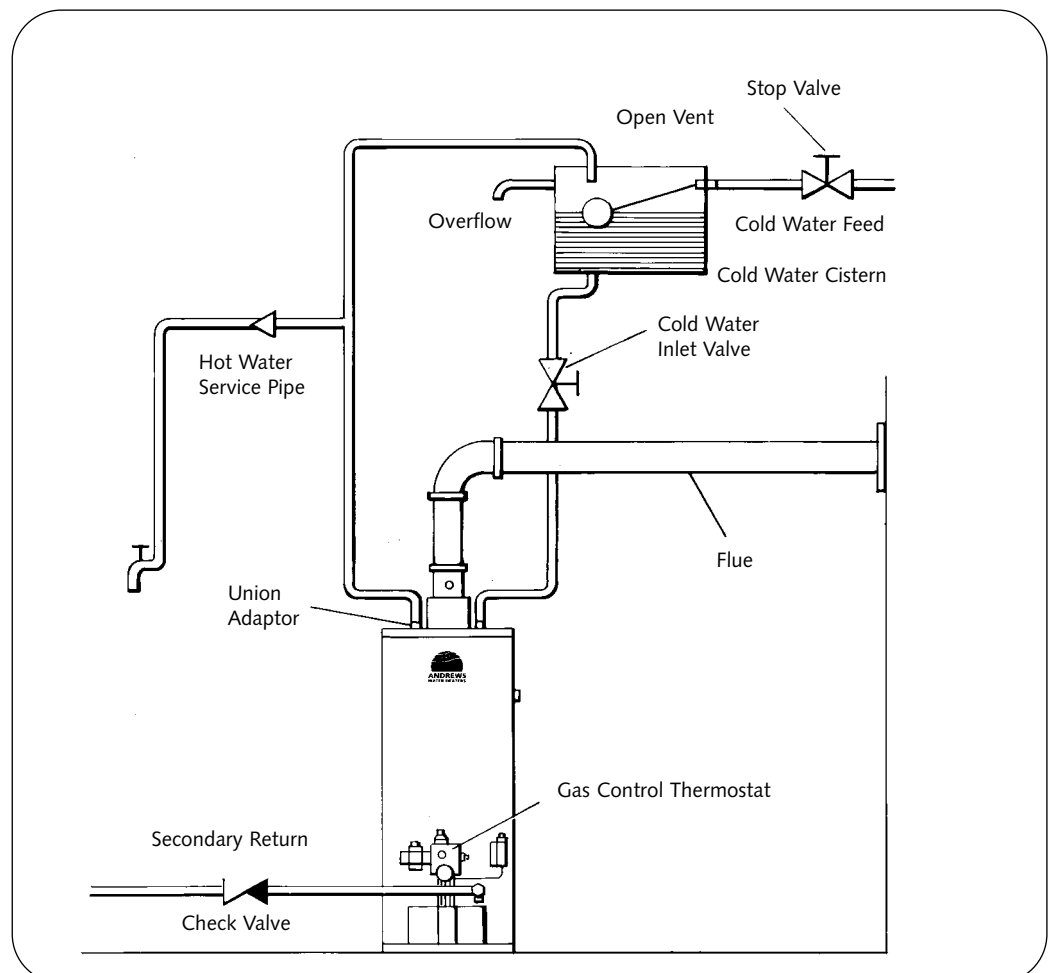

Fig.3
Typical Installation -
Vented System

When used in an unvented system, the Andrews storage water heater will supply hot water at a pressure of 3.5 bar (50.8 psi) providing this pressure is available at the mains feed. During conditions of no flow, whilst the burner is operating, the pressure of the system will rise to a maximum of 6 bar (87.0 psi).

When testing the system it is recommended that a maximum test pressure of 8.62 bar (125 psi) be employed.

The Andrews range of storage water heaters can be used on unvented hot storage water systems with the addition, to the standard heater, of an "Unvented Systems Kit" Part No. B213 obtainable from Andrews Water Heaters.

All fittings and materials must be suitable for use with drinking water and listed in the current Water Research Centre "Materials and Fittings Directory".

Installation of unvented hot storage water systems must comply with the requirement G3 of the Building Regulations.

Fig.4 p11 lists and illustrates the component parts of the Unvented Systems Kit. Fig.5 p12 illustrates the general arrangement of the components. The Wall Mounting Kit is available as an optional extra.

Item F4 must be fitted into the Temperature Relief port (see Fig. 6, p13)

When assembling items F1 and F2 care must be taken to ensure that the flow arrows marked on the components are pointing in the direction of flow i.e. towards the water heater.

The cold water for services may be drawn from the 22mm compression port on item F1(a). The water pressure at this point will be similar to that available at the hot water outlet of the water heater. If port (a) is not used it should be sealed with the blanking plug supplied.

If higher flow rates are required for the cold water services a suitable "tee" fitting should be included in the pipework upstream of item F1.

The discharge pipe from the tundish should be of suitable metal and be at least one pipe size larger than the outlet pipe on the safety devices.
(See Building Regulations Approved Document G3).

WATER CONNECTIONS UNVENTED SYSTEMS

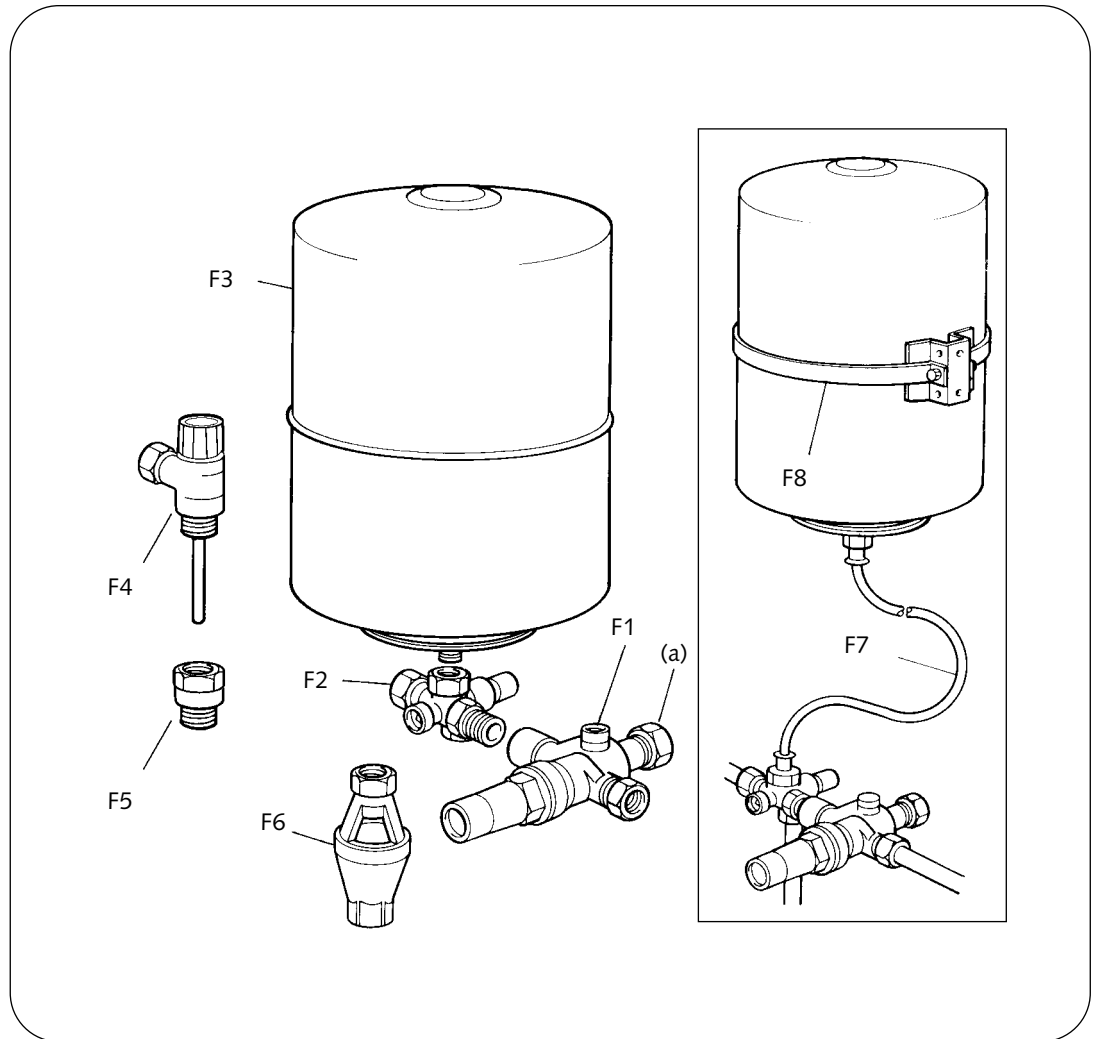

Fig. 4
Unvented
Systems Kit

Ref	Part No.	Description	Qty
	B213	Complete Unvented System Kit	1
Comprises			
F1	C780	Pressure Reducing Valve	1
F2	C781	Expansion Valve / Check Valve	1
F3	E319	Expansion Vessel	1
F4	E320	Temperature / Pressure Relief Valve	1
F5	E321	3/4" x 1/2" Reducing Bush	1
F6	E322	Tundish	1
	B229	Expansion Vessel Wall Mounting Kit (Optional)	1
Comprises			
F7	C788	Hose Assembly	1
F8	E323	Wall Bracket Assembly	1

WATER CONNECTIONS

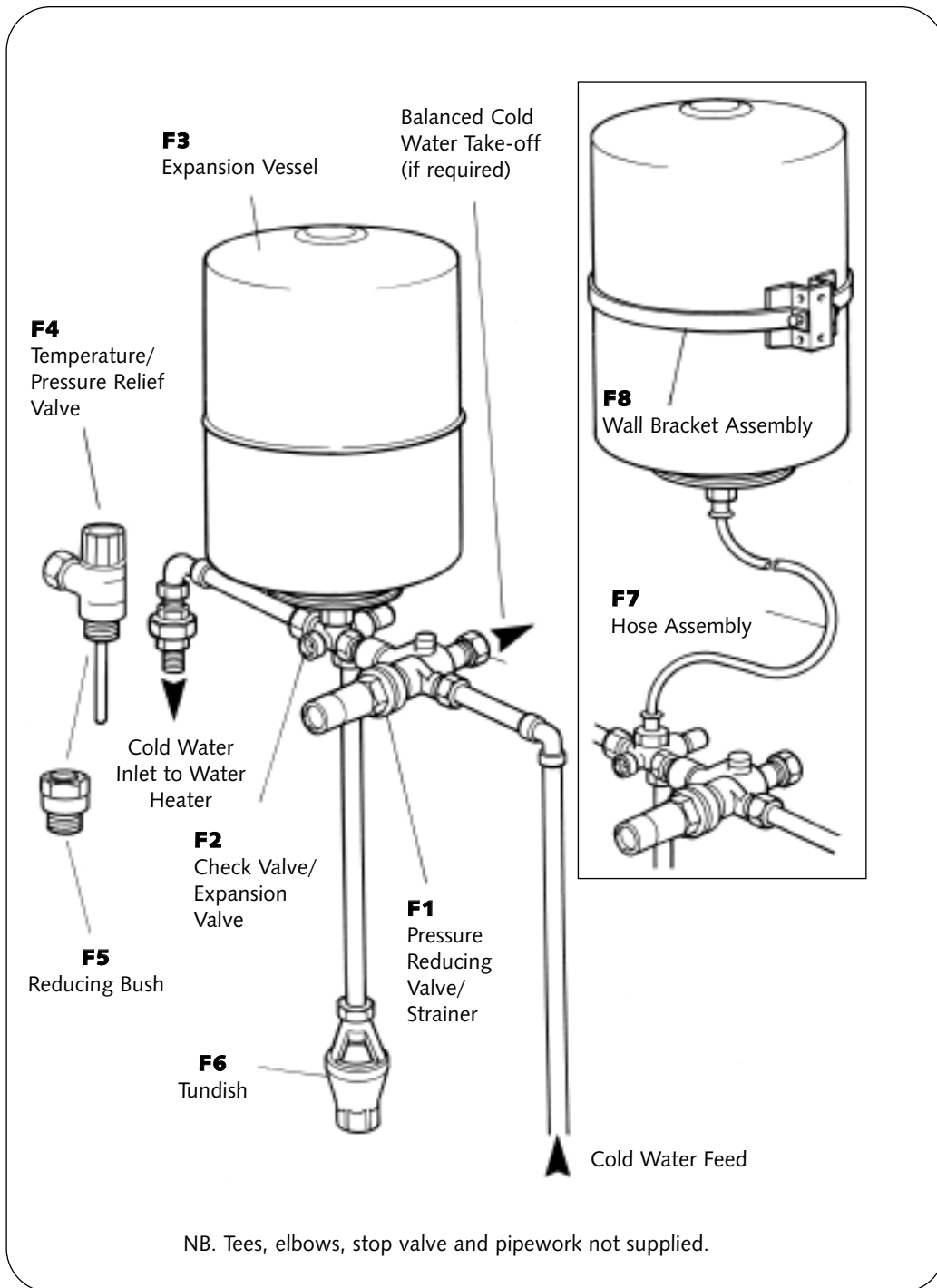

Fig.5
Unvented Systems Kit,
Correct Sequence

WATER CONNECTIONS

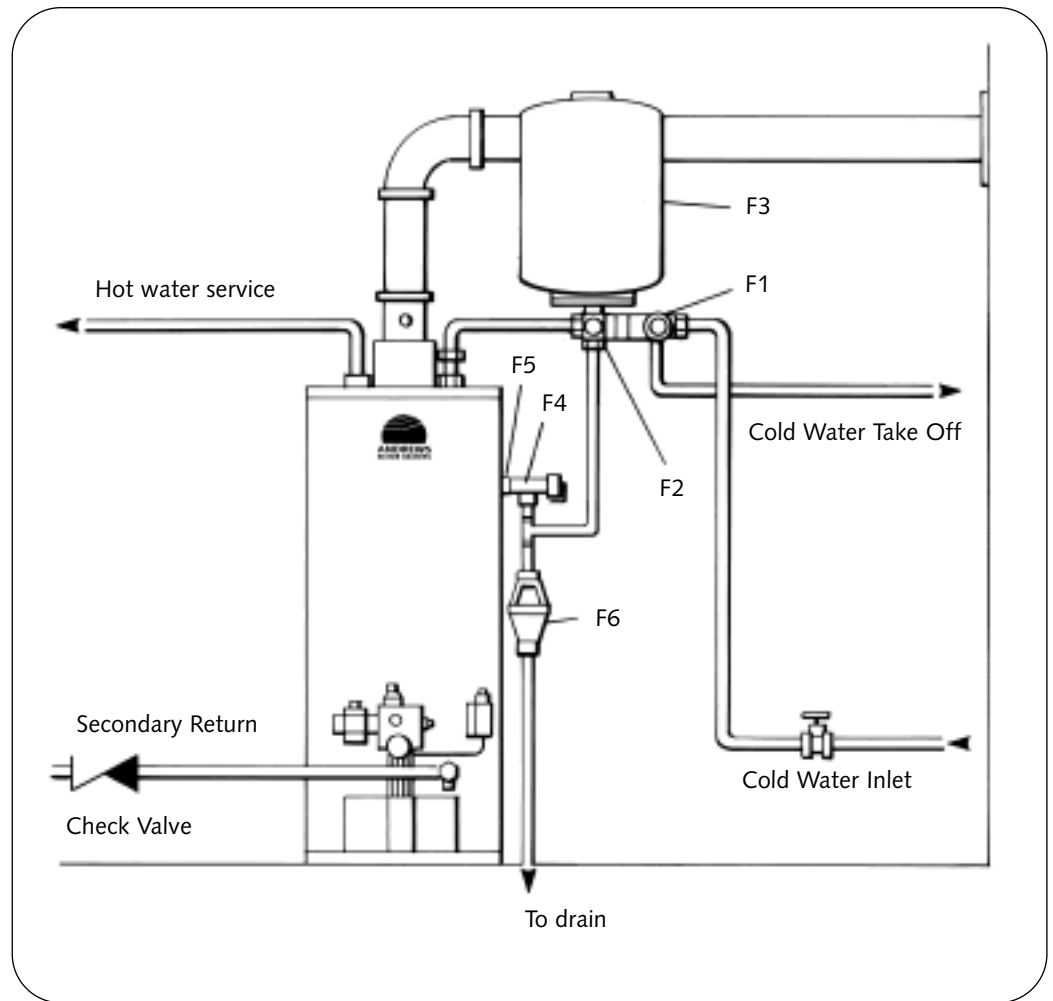

Fig. 6
Typical Installation,
Unvented System

GAS CONNECTIONS

THE APPLIANCE MUST ONLY BE USED WITH NATURAL GAS.

The installation of the gas supply should conform to the requirements of IM/16 published by British Gas p.l.c. or BS 6891. Jointing compound used must conform to BS 6956 Pt 5.

CAUTION - DO NOT APPLY HEAT IN CLOSE PROXIMITY TO THE GAS CONTROL THERMOSTAT AS THIS WILL RESULT IN DAMAGE OCCURRING TO THE CONTROL.

Fit a 1/2" gas supply cock immediately upstream of the gas control thermostat and connect to the gas supply. Pressure test the gas installation for soundness. If any doubt exists as to size of gas supply pipe, consult your local Gas Region.

It is recommended that a pressure test point is fitted on the input next to the gas supply valve.

GAS CONNECTIONS

TO LIGHT THE BURNER

Fig.7
Lighting Instructions

TO SHUT OFF THE BURNER

TO CHECK MAIN BURNER PRESSURE

Fig. 8
Burner Pressure Adjustment

CAUTION: DO NOT OPERATE THE WATER HEATER UNTIL THE STORAGE VESSEL IS COMPLETELY FILLED WITH WATER, WITH WATER RUNNING FROM ALL HOT TAPS.

Open the main gas supply cock after all connections to the gas control thermostat are complete, and test all connections with soap solution.

1. Remove outer cover wait 3 minutes for any unburnt gas to vent.
2. Turn the gas control knob to pilot. (see below)
3. Fully depress the gas control knob and the piezo ignitor. With the pilot burner alight, hold the gas control knob for 20 seconds. When the gas control knob is released the pilot should remain lit, if not repeat the operation. The pilot can be seen through the sight glass on the inner cover.
4. Replace outer cover.
5. Set the temperature indication dial to the required temperature. (see below)
6. Turn the gas control knob to ON, the burner should now light, if not repeat the operation. (see below)

Thermostat Setting	0		1		2		3	
Approx. Water Temperature	104°F	40°C	125°F	52°C	143°F	62°C	159°F	71°C

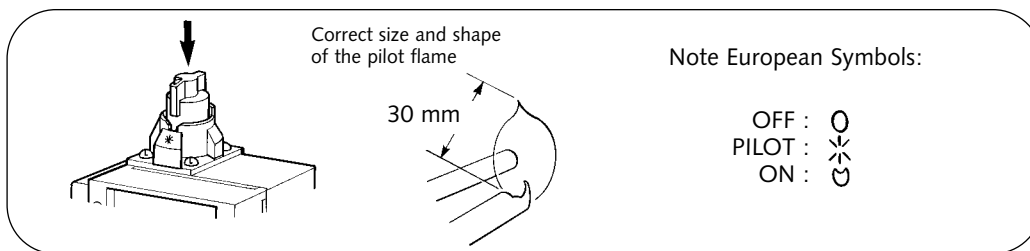

For long periods only, eg. holidays or periods of 7 days or more, turn the gas control knob to 'PILOT' position, depress slightly and turn clockwise to 'OFF'. Turn off the gas service cock.

For shorter periods, eg. less than 7 days, leave the heater under the control of the thermostat.

N.B. If the pilot should become extinguished for any reason, turn off the appliance, and wait three minutes before attempting to relight.

1. Turn burner OFF as above.
2. Remove brass cap from burner adjustment port. (see below).
3. Release bleed screw A one turn and connect pressure gauge tube.
4. Light burner according to the preceding instructions.
5. Adjust burner pressure at screw B in accordance with data plate.
Turn screw clockwise to increase pressure and anticlockwise to decrease pressure.
6. Turn burner OFF. Remove pressure gauge tube and tighten screw A.
7. Replace brass cap in burner pressure adjustment port. (see below).

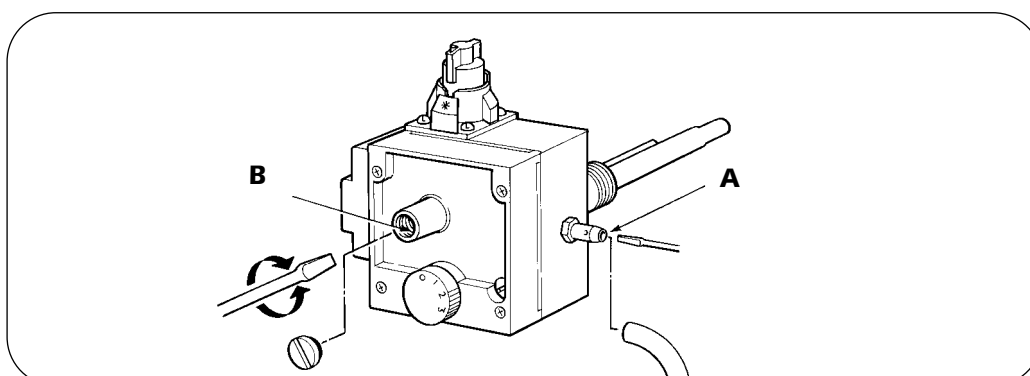

LIGHTING THE BURNER AUTO IGNITION

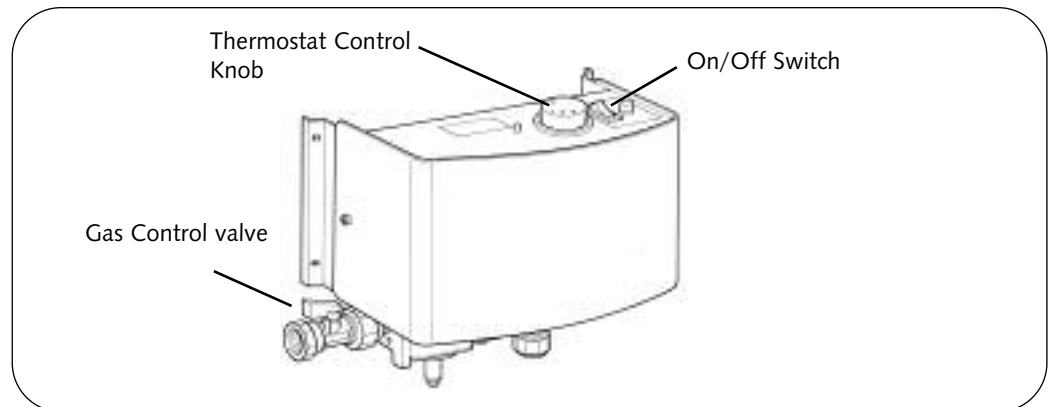

1. Ensure gas supply is on.
2. Set thermostat control knob to the required water temperature. (See below).
3. Ensure time switch if fitted is in the ON position.
4. Move electrical ON/OFF switch to ON and the burner will light.
5. Check pilot and main gas connections at gas control valve using leak detection fluid whilst burner is alight. Turn OFF, seal any leakages then re-test.

Shutting OFF burner

To shut OFF the burner move switch to OFF then turn OFF the gas service cock.

The water heater should only be turned OFF for long periods, eg holidays, or in an emergency. Otherwise the heater should be left to operate under normal thermostat control.

NB. When using a time control ensure the heater is not turned OFF before the final water draw off occurs. This will ensure the water in the tank is left in a hot condition.

THERMOSTAT SETTING	1		2		3	
APPROX WATER TEMP.	104°F	40°C	131°F	55°C	158°F	70°C

Checking main burner pressure

1. Turn gas supply OFF.
2. Release bleed screw A and connect pressure gauge tube.
3. Light burner as described previously.
4. Remove cap from port B and adjust pressure using exposed screw in accordance with data plate.
5. Shut OFF burner as described previously. Remove pressure gauge tube and tighten bleed screw A.
6. Re-light burner as described previously.

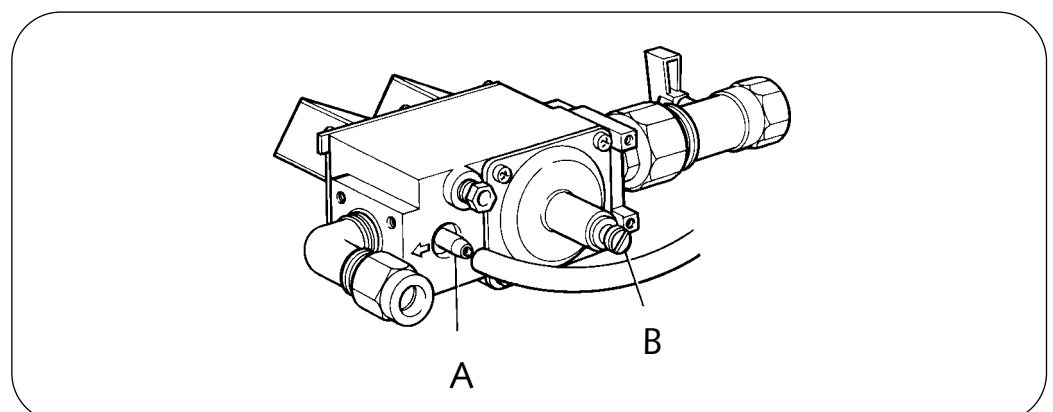

When properly installed and adjusted the Heater will require the minimum of attention. Should it become necessary to completely drain the heater, close the cold water inlet valve, open a hot water tap to allow air to enter the system. Fit a suitable hose to the drain cock and open.

Whenever the Heater is filled with cold water, condensation will form on the cold storage vessel surfaces when the burner is lit. Condensation is normal and does not indicate a leak. It will disappear when the storage vessel becomes heated.

The gas control fitted to this heater has a built in limit thermostat (ECO). In case of high water temperature the gas supply will be automatically shut off. The reason for such a high temperature must be investigated and corrected before the heater is relit.

The gas control is fitted with a recycling type ECO, this means that once the water temperature has cooled sufficiently the ECO circuit will close and allow the heater to be relit. If the gas control has to be changed it must be replaced with an identical model having the same code number.

1. When the thermostat senses too-cool water, a signal is sent to the control sequence unit.
2. The pilot solenoid coil is energised and thus allowed to open. Gas is allowed to pass to the pilot and ignition begins.
3. When the pilot flame is established, the main gas solenoid is energised and allowed to open and the main burner is lit.
4. When the control thermostat is satisfied, both pilot and main gas solenoids are closed.

AUTO IGNITION UNITS

Temperature Stratification (Stacking)

When small amounts of hot water are drawn repeatedly, the thermostat responds to each feed of cold water and activates the main burners. Each time this occurs, more heat may be put back in the tank than was drawn off. As this continues, water in the upper level of the tank gets hotter than the thermostat setting. This hotter water does not mix completely with the cold inlet water but rises in a 'chimney effect' to the top of the tank. Many repetitions of this over a short time period result in accumulation of excessively hot water in the upper part of the tank, even when the thermostat control is within limits. This is known as stacking.

If in doubt contact Andrews Water Heaters.

Whilst giving the following instructions for the care of the Andrews Water Heater, we would recommend that an arrangement is made with your local gas region or installer to carry out periodic checks of the appliance to ensure trouble free operation and continued satisfaction.

BURNER ASSEMBLY

The burner assembly should be cleaned and checked annually as follows:-

1. Depress slightly the gas control knob and turn to "OFF". Remove the outer burner cover and the inner door. Remove the IO fixing screws to remove the inner cover.
2. Disconnect from the bottom of the control valve the 'pilot tube, thermocouple and main burner supply tube. Withdraw the burner assembly from the heater.
3. Remove the screw securing the pilot assembly to the main burner.
4. Remove the gland nut connecting the pilot tube to the pilot assembly. Withdraw the pilot tube and remove the pilot restrictor from the end. Clean the pilot restrictor with acetone and blow through the pilot burner with compressed air.
5. Remove the two screws securing the main burner supply tube to the bottom of the burner to gain access to the main jet. Remove the main jet and clean with acetone. Blow through the main burner with compressed air.

DO NOT ATTEMPT TO CLEAN ORIFICES WITH SHARP METALLIC OBJECTS, IF NECESSARY, USE A WOOD SPLINTER TO CLEAR.

6. Re-assemble in the reverse order of steps 2 to 5 but note:
 - i) Be sure to engage the rear section of the main burner supply pipe in its location bracket on the base pan of the heater.
 - ii) **DO NOT OVERTIGHTEN THE THERMOCOUPLE CONNECTION, SCREW IN FINGER TIGHT AND TIGHTEN A FURTHER 1/4 TURN USING A SPANNER.**
7. Turn the control knob to "PILOT" and depress. Using a leak detection fluid check the joints at both ends of the pilot supply tube. Seal if necessary.
8. Allow 3 minutes for any unburnt gas to disperse and light the pilot flame, check that the flame is correct, see Fig. 7 and turn the control knob to 'ON', the main burner will light.
9. Check the main burner tube connection at the control valve with leak fluid and seal if necessary. Replace the outer cover.

GAS CONTROL VALVE

This should be checked and serviced by an engineer fully conversant with every aspect of this piece of equipment.

Fig. 9
Replacement of
Gas Control

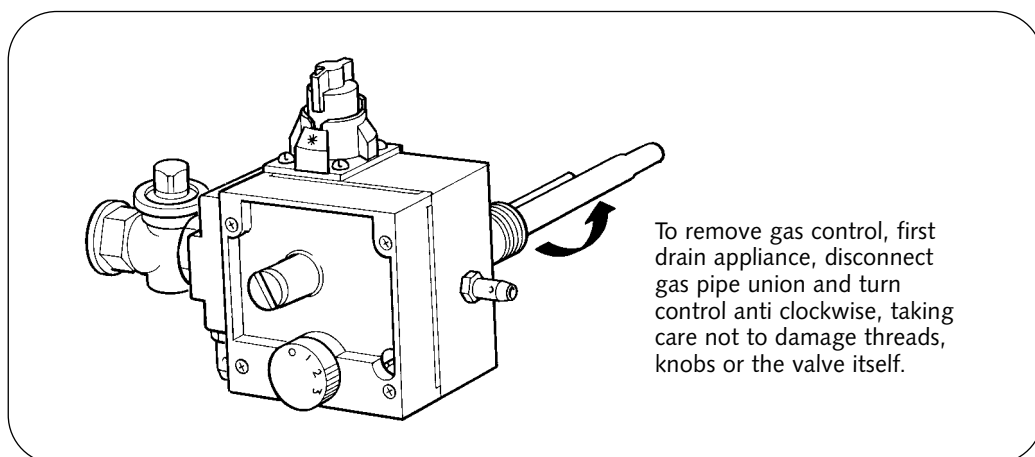

The burner should be checked annually. The flueway and baffle should be checked if sooting occurs and if necessary cleaned as follows:-

1. Depress slightly the gas control knob and turn to "OFF". Remove outer burner cover and inner cover. Remove the fixing screws to remove the inner cover.
2. Disconnect burner gas tube, pilot tube and thermocouple at gas control.
3. Remove burner assembly complete with pipes and thermocouple lead.
4. Remove flue assembly and flue box on heater to reveal flue baffle.
5. Inspect and clean the secondary flue installation as necessary.
6. Lift out the baffle from inside the central flueway.
7. Clean the flueway with a brush and clean any deposit from the underside of the storage vessel bottom and from the flue baffle.
8. Re-assemble in the reverse order.
IT IS IMPORTANT THAT THE BURNER IS CORRECTLY LOCATED IN THE BURNER SUPPORT BRACKET ON BASE OF COMBUSTION CHAMBER. DO NOT OVERTIGHTEN THE THERMOCOUPLE CONNECTION.
Screw in hand tight and tighten an extra 1/4 turn with a spanner.
9. Re-light and carry out commissioning check as above.

IMPORTANT

A magnesium sacrificial anode is fitted into the top of the water storage vessel. The function of the anode is to provide additional corrosion protection for the inside of the vessel. The condition of the anode should be checked, at least annually, during servicing. The original diameter of the anode is 22mm (7/8"), if at any point along its length, the anode is eroded to half, or less, of the original diameter it should be replaced with new. Particular attention should be paid to the extreme ends. The anode/hot outlet nipple can be unscrewed from the top of the heater (see page 20). If the anode is encrusted with limescale it should be either cleaned by wire brushing to reveal bright metal or replaced.

Where correx anodes are fitted no anode maintenance is required.

CLEANING THE STORAGE VESSEL

Scale formation in the base area of the storage vessel which may occur in hard water areas. It is usually associated with high usage and high water temperatures. It is characterised by a rumbling noise (kettling) when the burner is lit and should be rectified by chemical descaling.

DESCALING

When descaling the water storage heater your attention is drawn to the following guidelines.

SAFETY FIRST

DUE TO THE CORROSIVE NATURE OF THE DESCALE FLUID IT IS ESSENTIAL THAT SUITABLE PROTECTIVE CLOTHING EQUIPMENT IS USED AND ADEQUATE VENTILATION IS AVAILABLE WHEN DESCALING.

1. Turn gas control on water heater to 'OFF' position and isolate the gas supply.
2. Close water inlet valve and drain heater tank.
3. Remove magnesium sacrificial anode (s).
Note: It is recommended that a new anode(s) is fitted.
4. Add suitable hydrochloric based descale acid, the requirement is normally 5 litres for standard range or more dependent on the amount of limescale present.
5. After a minimum of one hour restore gas supply and turn on main gas burner for 2 minutes (MAXIMUM).
6. Isolate gas supply and drain off descale fluid through drain port.
7. Open cold water feed valve and fill heater tank.
8. Drain and flush out heater for minimum of 30 minutes.
9. Replace anodes.
10. Replace gas supply and re-light heater.

FLUEWAY

MAGNESIUM ANODE

FAULT	ACTION
1. WATER DOES NOT GET HOT	(a) Check gas cock is open. (b) Check water valves are open. (c) Check that pilot is alight. (d) Check thermostat setting. (Reset to higher temperature). (e) Check gas pressures at burner and at gas inlet to appliance. (f) Check cold inlet dip tube to see if it is broken or missing (see Fig. 10).
2. PILOT FLAME IS OUT	(a) Try to light burner as detailed in lighting instructions. (b) Pilot will not light wait 3 mins and try again then see below.
3. PILOT WILL NOT STAY ON	(a) Check gas available. (b) Check thermocouple, replace if necessary. (c) Check inlet gas pressure as this may be too high or too low. Inlet gas pressure to heater multifunctional control should be 17.5 mbar (7" Wg) to 25 mbar (10" Wg). (d) Pilot jet blocked, clean or replace pilot jet. (e) Faculty magnet, replace multifunctional control. (f) E.C.O. safety thermostat operating at too low a temperature. Replace multifunctional control.
4. BURNER WILL NOT LIGHT - PILOT ESTABLISHED	(a) Water already at correct temperature. (b) Replace multifunctional control.
5. THERMOCOUPLE BURNS OUT FREQUENTLY	(a) Check pilot pipe for loose joints. (b) Check that correct amount of fresh air ventilation is available. (c) Check that flue is clear and is correctly designed and fitted. (d) Check for presence of halogen vapours (see page 7).
6. HEATER SOOTING, YELLOW FLAME (POOR COMBUSTION)	(a) Clean burner and injector. (b) Flue obstruction, clean flueways. (c) Check flue design and termination position. (d) Check burner pressure. (e) Check for correct ventilation.
7. WATER TEMPERATURE TOO HIGH	(a) Reset thermostat to lower temperature. (b) If water temperature is still too high replace multifunctional control.
8. WATER TEMPERATURE TOO LOW	(a) Reset to higher temperature. (b) Check gas pressures at burner and at gas inlet to appliance.
9. NOT ENOUGH HOT WATER	(a) Check gas pressures at burner and at gas inlet to appliance. (b) Check amount of water being used against recovery rate given on Data Plate.
10. WATER DRIPPING FROM BASE OF HEATER	(a) Check if water stops dripping when water in heater is hot. If water stops problem is condensation caused by incorrectly designed flue or by tank cooling excessively i.e. more hot water being used than recovery rate of the heater. (b) If water continues to drip when heater is hot. Problem is a leaking joint or storage vessel.
11. RUMBLING NOISE (KETTILING)	(a) Scale formation in heater, consult water treatment specialist. Heater must be descaled and suitable water treatment provided to avoid problem re-occurring.

Fig. 10
Removal of
Cold Inlet Dip Tube
& Hot Outlet
Nipple/Anode

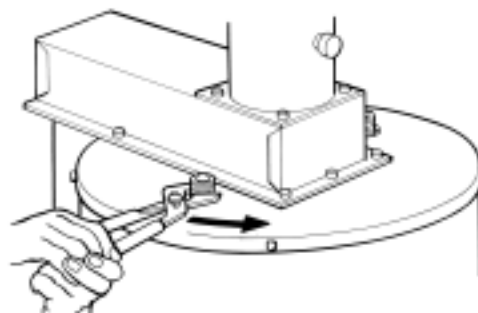

Disconnect pipe fittings and turn nipple anti clockwise to remove.

**AUTO
IGNITION
UNITS**

FAULT	ACTION
NO IGNITION AT PILOT	(a) Check gas service cock is open. (b) Electrical ON/OFF switch is not ON. (c) Power to unit interrupted. (d) Thermostat set too low. (e) Check ECO for failure. Reset. (f) Check for 24V AC at intermittent pilot ignition control terminal No. 1. Replace control if faulty. (g) Faulty Solenoid Coil. Replace if faulty.
PILOT LIGHTS BUT MAIN BURNER DOES NOT	(a) Check for 24V AC at intermittent pilot ignition control terminal No. 3. Replace control if faulty. (b) Faulty Solenoid Coil. Replace if faulty.

Model	RSC150	RSC190		
Ref	Part No.	Part No.	Description	Qty
A1	E080	E081	Data Plate	1
A2	E085	E086	Hot Outlet Nipple / Anode	1
A3	E087	E088	Hydrojet Cold Inlet Dip Tube	1
A4	C247	C247	3/4" NPT/BSP Nipple	2
A5	C381	C381	Drain Cock	1
A6	C103	C103	3/4" Socket	1
A7	E089	E089	Combustion Chamber Seal Cover	1
A8	E090	E090	Cover Burner Access	1
A9	E091	E092	Flue Baffle	1
B1	E093	E094	Burner Assembly Comprising items B2, B3, B4, B5, B6	1
B2	E095	E095	Burner Supply Pipe	1
B3	E097	E097	Pilot Supply Pipe	1
B4	C126	C126	Thermocouple	1
B5	E099	E100	Injector	1
B6	E101	E101	Pilot Burner c/w Jet, Pipe, Electrode & Lead	1
B7	C252	C252	Pilot Burner Jet N18	1
B8	C514	C514	Piezo Ignitor	1
B9	C965	C965	Multifunctional Control, White Rogers	1
B10	E016	E016	Thermostat Knob	
B11	C382	C382	Gas Cock	1
C1	E103	E103	Top Cover	

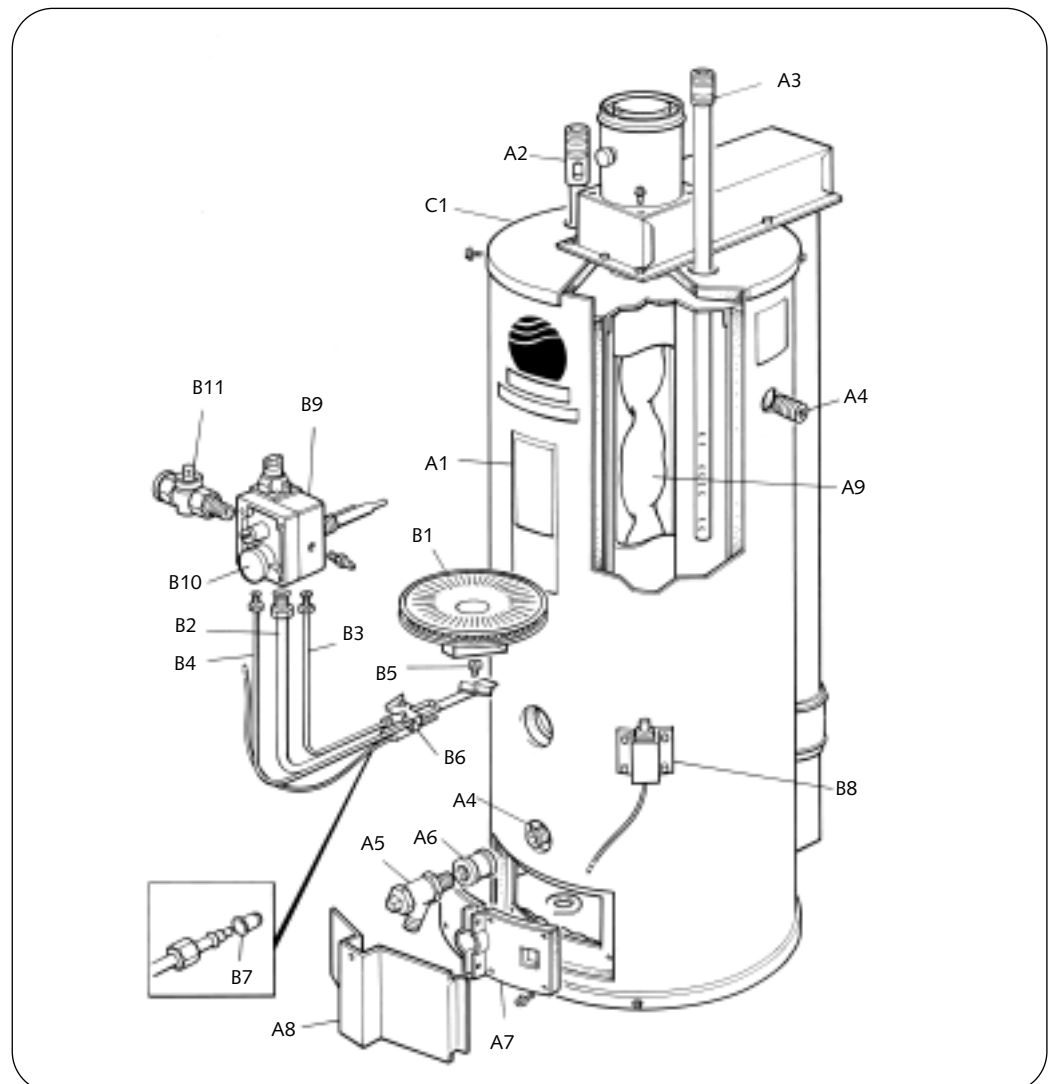

Model	RSC 150	RSC 190		
Ref	Part No.	Part No.	Description	Qty
D1	E072	E072	Heater Adaptor	1
D2	E069	E069	0.5m Flue	1
D3	E073	E073	Horizontal Terminal c/w Wall Plates	1
D4	E071	E071	90° Bend	1
D5	E067	E067	Vertical Terminal	1
D6	E075	E075	Clamp with Seal	2
D7	E074		Flue Restrictor 45mm (Vertical)	1
D7	E076		Flue Restrictor 60mm (Horizontal)	1
D7		E077	Flue Restrictor 48mm (Vertical)	1
D7	E078		Flue Restrictor 50mm	1
D7		E107	Flue Restrictor 55mm	1
D8	E065	E065	Flat Roof Plate	1
D9	E066	E066	Angled Roof Plate	1
D10	E105	E105	Horizontal Flue Outlet Terminal Guard	1

Note:

Straight lengths of flue can be supplied to suit each installation requirements as shown on page 6 See below.

Part No.	Description
E064	1m Flue
E070	1m Cutable Flue
E068	Wall Clamp
E308	45° Elbow

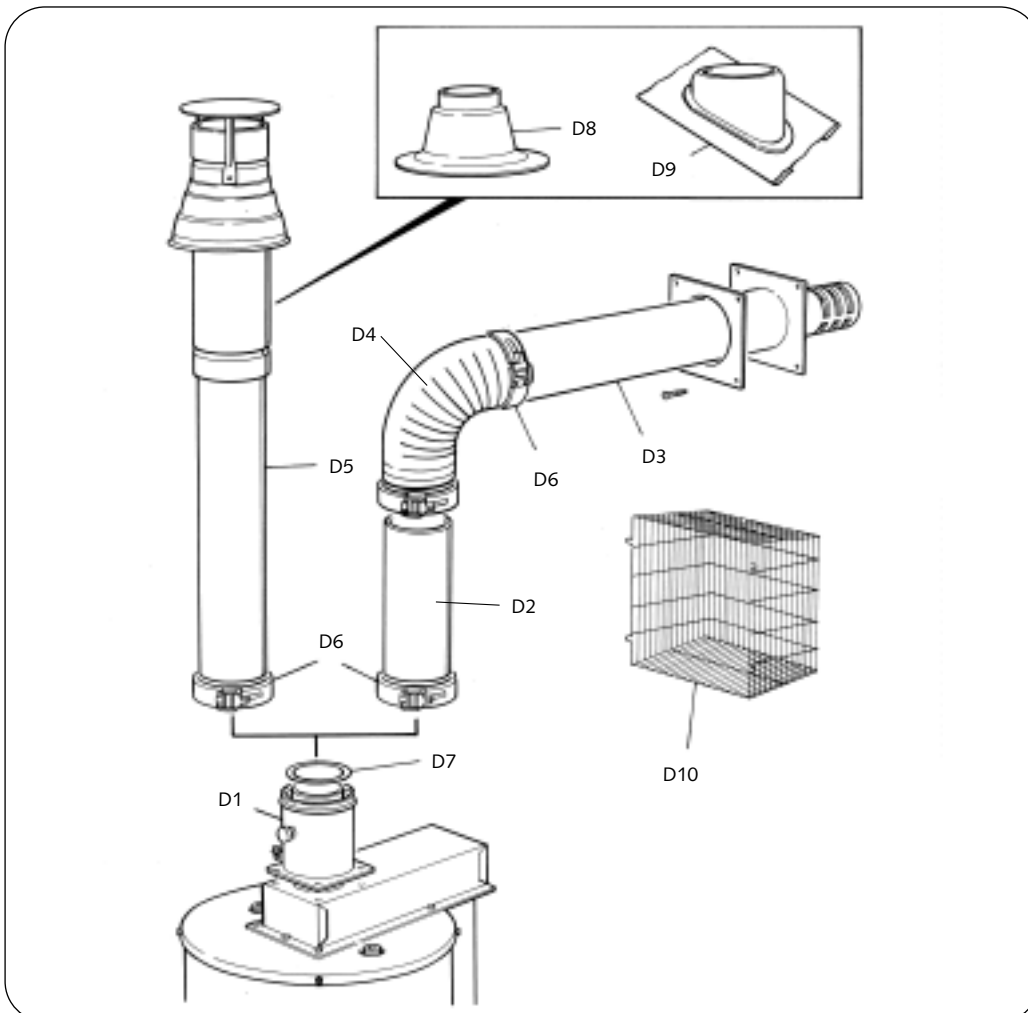

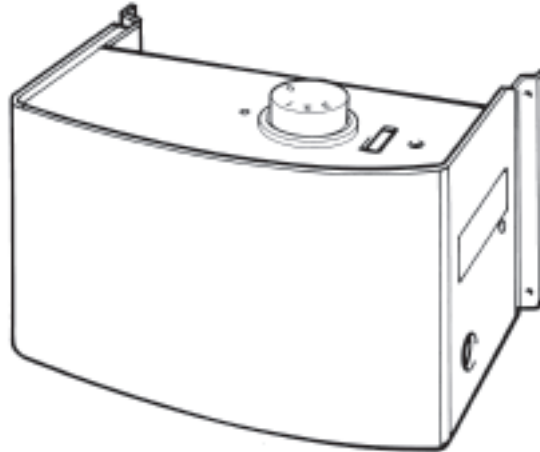

**24 Volt Auto System
Kit B217**

**24 Volt Auto
System Kit**
Standard Range

Part No.	Description	Qty
B217	240 Volt Auto System Kit Complete (nat gas)	1
C521	On/Off Switch	1
C641	Mains Indicator Light	1
G122	EP6 Control Module	1
E115	Transformer	1
E116	Limit Thermostat	1
E117	Control Thermostat	1
E120	Control Thermostat Knob	1
G059	230 volt Gas Valve	1
E126	230 volt Solenoid Coil	2
E127	Pilot Assembly (nat gas)	1
E128	Ignition/Flame Probe	1
E135	HT Lead 24"	1

PART OF BDR THERMEA

Baxi Commercial Division
Wood Lane, Erdington,
Birmingham B24 9QP
Email: andrews@baxigroup.com
www.andrewswaterheaters.co.uk

Sales:
0845 070 1056
Technical:
0845 070 1057

