

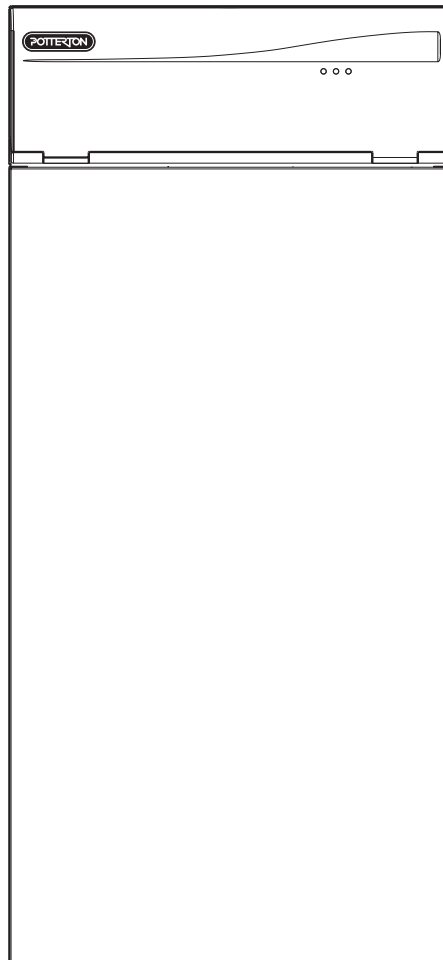

Installation & Service Instructions Benchmark Commissioning Checklist

Promax FSB 30 HE Floor Standing Fanned Flue Condensing Boiler



The boiler meets the requirements of Statutory Instrument " The Boiler (Efficiency) Regulations 1993 N° 3083" and is deemed to meet the requirements of Directive 92/42/EEC on the energy efficiency requirements for new hot water boilers fired with liquid or gaseous fuels:-

Type test for purpose of Regulation 5 certified by:
Notified Body 0087.

Product/Production certified by:
Notified Body 0086.

For GB/IE only.

Only a flue approved for the Promax FSB 30 HE can be used.

These instructions include the Benchmark Commissioning Checklist and should be left with the User for safe keeping.

Natural Gas

Potterton Promax FSB 30 HE
G.C. No 41 595 39

Building Regulations and the Benchmark Commissioning Checklist

Building Regulations (England & Wales) require notification of the installation of a heating appliance to the relevant Local Authority Building Control Department. From 1 April 2005 this can be achieved via a Competent Persons Self Certification Scheme as an option to notifying the Local Authority directly. Similar arrangements will follow for Scotland and will apply in Northern Ireland from 1 January 2006.

CORGI operate a Self Certification Scheme for gas heating appliances.

These arrangements represent a change from the situation whereby compliance with Building Regulations was accepted as being demonstrated by completion of the Benchmark Logbook (which was then left on site with the customer).

With the introduction of Self Certification Schemes, the Benchmark Logbook is being withdrawn. However, a similar document in the form of a commissioning checklist and service interval record is incorporated at the back of these instructions.

This company is a member of the Benchmark initiative and fully supports the aims of the programme. Its aim is to improve the standards of installation and commissioning of central heating systems in the UK and to encourage the regular servicing of all central heating systems to ensure safety and efficiency.

Building Regulations require that installations should comply with manufacturer's instructions. It is therefore important that the commissioning checklist is completed by the installer. The relevant section of Building Regulations only relates to dwellings. Therefore the checklist only applies if the appliance is being installed in a dwelling or some related structure.

The flowchart opposite gives guidance for installers on the process necessary to ensure compliance with Building Regulations.

© Baxi Heating UK Limited 2005 All rights reserved. No part of this publication may be reproduced or transmitted in any form or by any means, or stored in any retrieval system of any nature (including in any database), in each case whether electronic, mechanical, recording or otherwise, without the prior written permission of the copyright owner, except for permitted fair dealing under Copyrights, Designs and Patents Act 1988.

Applications for the copyright owner's permission to reproduce or make other use of any part of this publication should be made, giving details of the proposed use, to the following address:

The Company Secretary, Baxi Heating UK Limited, Pentagon House,
Sir Frank Whittle Road, Derby, DE21 4XA.

Full acknowledgement of author and source must be given.

WARNING: Any person who does any unauthorised act in relation to a copyright work may be liable to criminal prosecution and civil claims for damages.



Baxi Heating UK Limited is a
BS-EN ISO 9001 Accredited Company



The code of practice for the installation,
commissioning & servicing of central
heating systems.

This product has an energy rating (A) on a scale of A to G.
For more information see www.boilers.org.uk. This is a certification mark.

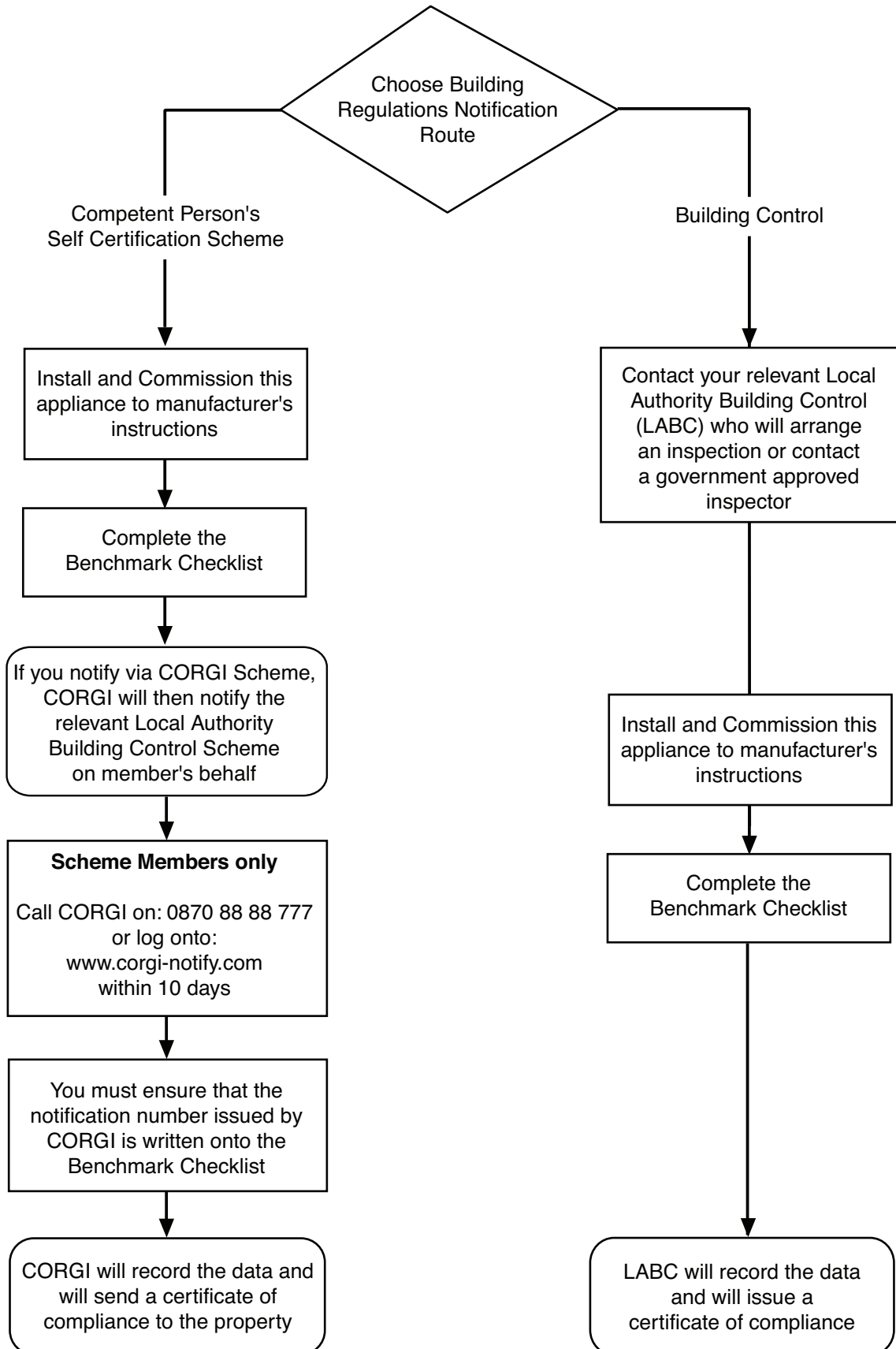

IMPORTANT - Installation, Commissioning, Service & Repair

This appliance must be installed in accordance with the manufacturer's instructions and the regulations in force. Read the instructions fully before installing or using the appliance.

In GB, this must be carried out by a competent person as stated in the Gas Safety (Installation & Use) Regulations.

Definition of competence: A person who works for a CORGI registered company and holding current certificates in the relevant ACS modules, is deemed competent.

All CORGI registered installers carry a CORGI identification card and have a registration number. You can check your installer is registered by telephoning 0870 4012300 or writing to:-

1 Elmwood,
Chineham Business Park,
Crockford Lane,
Basingstoke. RG24 8WG

or check online at www.corgi-gas-safety.com

In IE, this must be carried out by a competent person as stated in I.S. 813 "Domestic Gas Installations".

Lifting - This product should be lifted and handled by two people. For recommended hand holds see section 8.3. Stooping should be avoided and protective equipment worn where necessary. Carrying & lifting equipment should be used as required, e.g. when installing in a loft space.

The addition of anything that may interfere with the normal operation of the appliance without express written permission from the manufacturer or his agent could invalidate the appliance warranty. In GB this could also infringe the Gas Safety (Installation and Use) Regulations.

Potterton declare that no substances harmful to health are contained in the boiler or used during boiler manufacture.

The boiler is suitable only for installation in GB and IE, and must only be used in a suitably ventilated location.

The installation must be carried out in accordance with the relevant requirements of the:

- Gas Safety (Installation & Use) Regulations.
- The appropriate Building Regulations either The Building Regulations, The Building Regulations (Scotland), Building Regulations (Northern Ireland).
- The Water Fittings Regulations or Water Byelaws in Scotland.
- The Current I.E.E. Wiring Regulations.

Where no specific instructions are given, reference should be made to the relevant British Standard Code of Practice.

Codes of Practice

Most recent version should be used

In GB the following Codes of Practice apply:

Standard	Scope
BS 6891	Gas Installation.
BS 5546	Installation of hot water supplies for domestic purposes.
BS 5449	Forced circulation hot water systems.
BS 6798	Installation of gas fired hot water boilers.
BS 5440 Part 1	Flues.
BS 5440 Part 2	Ventilation.
BS 7074	Expansion vessels and ancillary equipment for sealed water systems.
BS 7593	Treatment of water in domestic hot water central heating systems.

In IE the following Codes of Practice apply:

Standard	Scope
I.S. 813	Domestic Gas Installations.

The following BS standards give valuable additional information;

BS 5546	Installation of hot water supplies for domestic purposes.
BS 5449	Forced circulation hot water systems.
BS 7074	Expansion vessels and ancillary equipment for sealed water systems.
BS 7593	Treatment of water in domestic hot water central heating systems.

In IE, the installation must be carried out in accordance with the current edition of I.S. 813 'Domestic Gas Installations', the current Building Regulations and reference should be made to the current ETCl rules for electrical installation.

All systems must be thoroughly flushed and treated with inhibitor (see section 6.2). Failure to flush and add inhibitor to the system will invalidate the boiler warranty.

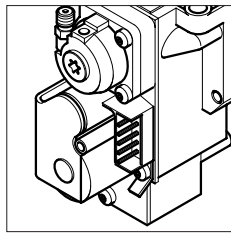
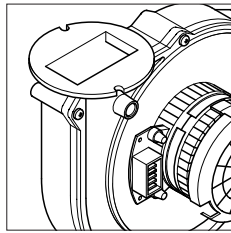
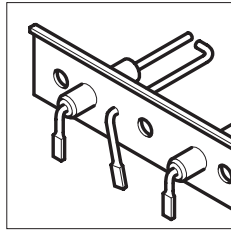

Contents

Section	Page
1.0 Introduction	6
2.0 General Layout	7
3.0 Boiler Operation	8
4.0 Technical Data	9
5.0 Dimensions and Fixings	10
6.0 System Details	11
7.0 Site Requirements	15
8.0 Installation	22
9.0 Electrical	27
10.0 Commissioning the Boiler	29
11.0 Completion	30
12.0 Servicing the Boiler	31
13.0 Changing Components	33
14.0 Short Parts List	40
15.0 Fault Finding	41
Benchmark Checklist	50

1.0 Introduction

1.1 Description

1. The Potterton Promax FSB 30 HE is a gas fired room sealed fan assisted condensing central heating boiler.
2. The maximum output of the boiler is 30.18 kW. The boiler automatically adjusts the output down to 9.2 kW according to system load.
3. The boiler is designed for use on Natural Gas (G20) only.
4. The boiler is suitable for fully pumped open vented and sealed systems, providing heating and hot water.
5. A label giving details of the model, serial number and Gas Council number is situated on the rear of the drop down facia panel (Fig. 1).
6. The boiler data badge is positioned on the air box door (Fig. 2).
7. The boiler is intended to be installed in residential / commercial / light industrial E.M.C. environments on a governed meter supply only.
8. The boiler must be installed with one of the purpose designed flues such as the standard horizontal flue kit, part no 236921.

1.2 Important Information

Man-made mineral fibre

- Some component parts of this boiler (insulation pads, gaskets and rope seals) are manufactured from man-made mineral fibre.
- Prolonged or excessive exposure to this material may result in some irritation to the eyes, skin or respiratory tract.
- It is advisable to wear gloves when handling these items.
- Irritant dust will only be released from the items if they are broken up or subjected to severe abrasion. In these instances a suitable dust mask and goggles should be worn.
- Always thoroughly wash hands after installation, servicing or changing components.
- When disposing of any items manufactured from man-made mineral fibre care must be exercised.
- If any irritation of the eyes or severe irritation of the skin is experienced seek medical attention.

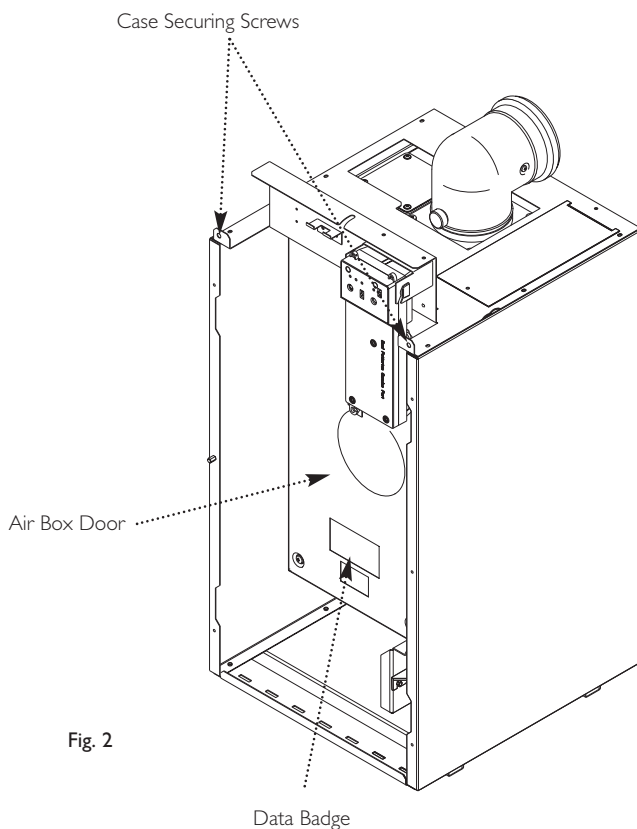
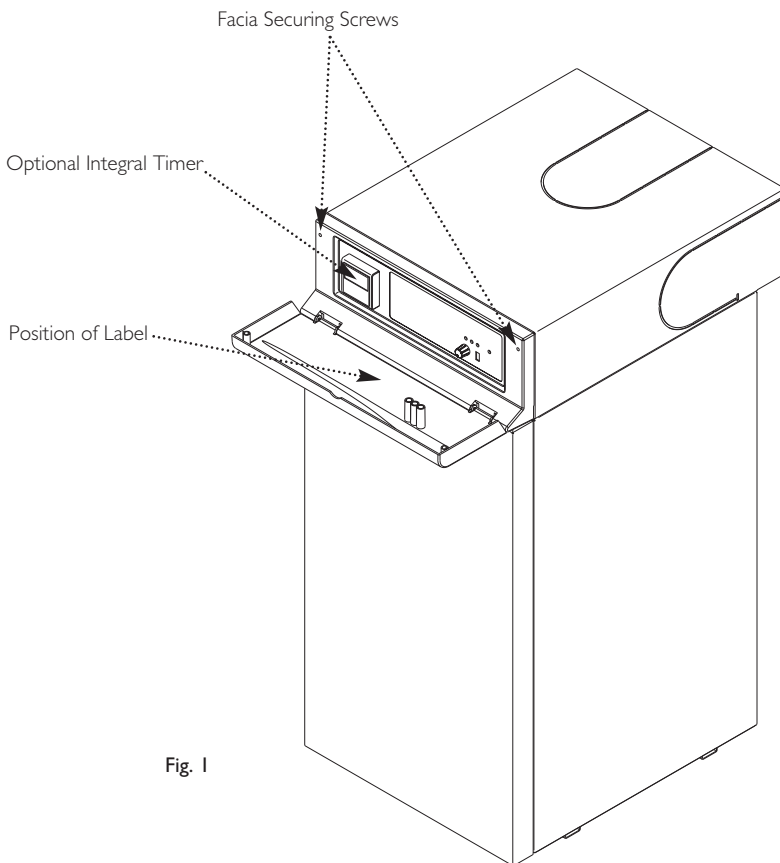

2.0 General Layout

2.1 Layout (Figs. 3, 4, 5 & 6)

1. Condensate Pump
2. Flue Elbow (supplied in std. flue kit)
3. Heat Exchanger
4. Burner
5. Air Box
6. Fan Protection Thermostat - Black
7. Fan Assembly
8. Condensate Trap
9. PCB Housing Assembly
10. Gas Tap
11. Gas / Air Ratio Valve
12. Flow Pipe Connection
13. Return Pipe Connection
14. Flow Temperature Safety Thermostat - Black
15. Flow Temperature Thermistor - Red
16. Flow Switch (dry fire protection)
17. Position of Optional Integral Timer Wiring
18. Pipe Access Panel
19. Manual Air Vent

2.2 110Ø Concentric Flues & Optional Extras

KIT	PART N°
Standard Flue Kit 850mm (inc. elbow)	236921
Extended Flue Kit - 1.75M (inc. elbow)	5111457
Flue Plume Deflector Kit	248167
Terminal Guard (suitable for use with above)	248484

FLUE EXTENSION KITS (110/70)

Flue Extension 250mm	241692
Flue Extension 500mm	241694
Flue Extension 1000mm (Use two kits for 2M etc.)	241695
Flue Bend x 2 - 45° (Reduce overall length of flue by 0.5m when fitting this bend)	241689
Flue Bend - 93° (Reduce overall length of flue by 1m when fitting each bend)	241687

VERTICAL FLUE

Vertical Flue Terminal	242802
Vertical Flue Adaptor	5106888

See Section 7.12 for more flue option details

Integral Twin Channel Timer	5117455
-----------------------------	---------

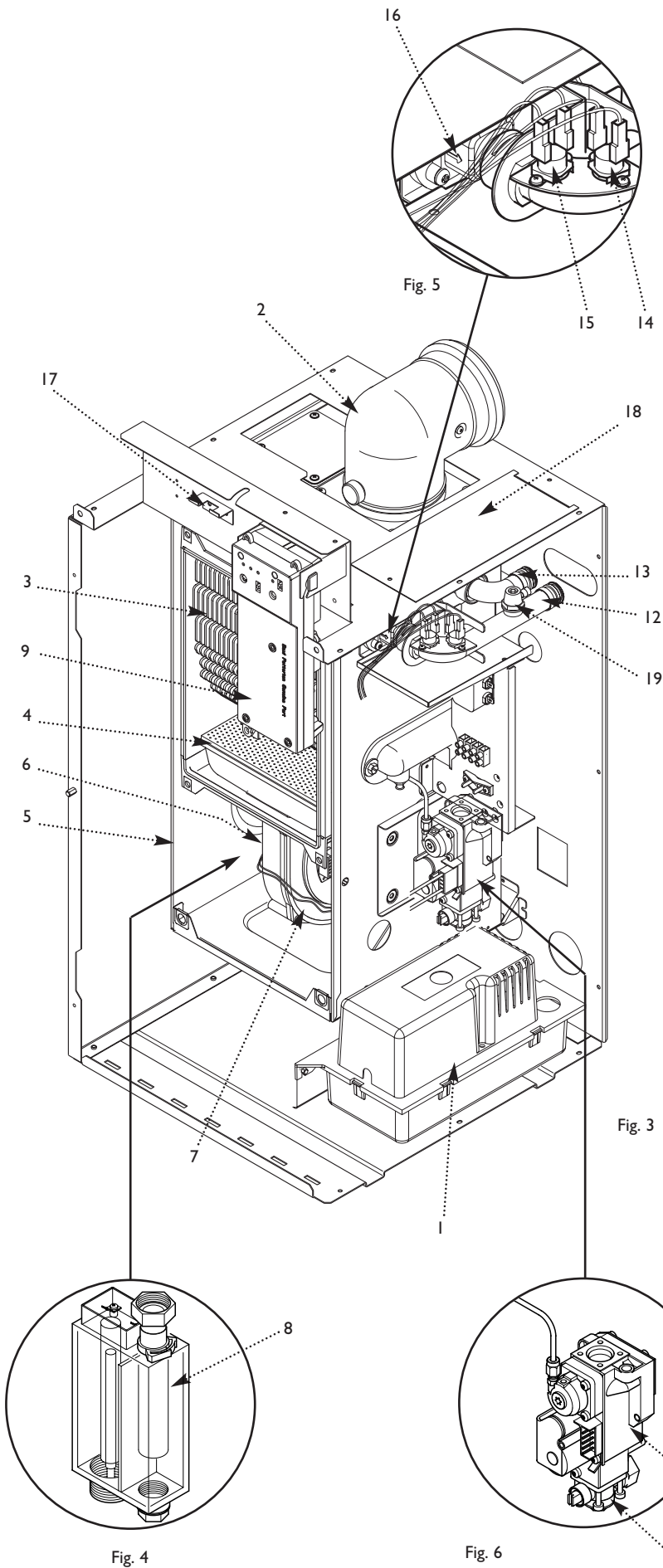

3.0 Boiler Operation

3.1 Boiler Operation

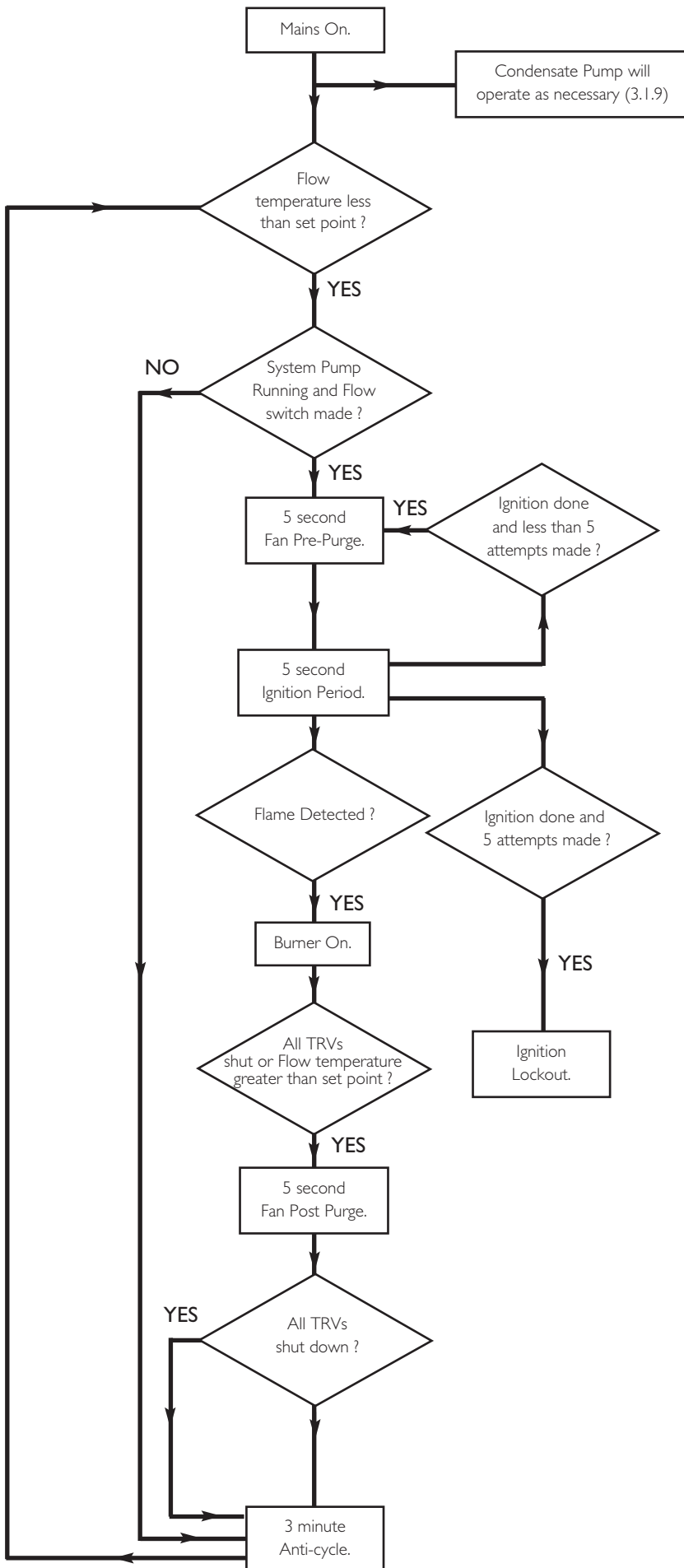

1. **Switched Live On:** When switched live is supplied to the boiler and the flow temperature is less than the set point the sequence below commences.

2. **Flow Switch:** After 10 seconds if the flow switch has made then fan pre-purge occurs. After 10 seconds if the flow switch has not made then anti-cycle occurs.

3. **Fan Pre-Purge:** The flow switch is made and the fan is on while the spark generator and gas valve are off. After 5 seconds ignition occurs.

4. **Ignition:** The flow switch is made, fan, spark generator and gas valve are on. If a flame is detected then burner on occurs. If a flame is not detected within 5 seconds and less than 5 ignition attempts have been made then fan purge occurs. If a flame is not detected within 5 seconds and 5 ignition attempts have been made then ignition lockout occurs.

5. **Burner On:** The flow switch is made, fan and gas valve are on while the spark generator is off. Flow temperature is controlled by varying the fan speed (and thereby the gas rate) to achieve optimum operation. If the flow temperature is greater than the set point or the TRVs all shut down then fan post purge occurs.

6. **Fan Post Purge:** The fan is on while the spark generator and gas valve are off. After 5 seconds if the TRVs are shut down then anti-cycle occurs.

7. **Anti-cycle:** The fan, spark generator and gas valve are off.

8. **Ignition Lockout:** The fan, spark generator and gas valve are off. The boiler can only be reset by manually using the reset button.

9. **Condensate Pump:** Condensate accumulates in a reservoir within the pump assembly. The pump may run at any time, independent of boiler operation, to discharge the condensate to drain.

4.0 Technical Data

Appliance Type	C ₁₃	C ₃₃
Appliance Category	CAT I 2H	
Heat Input (Q)(Gross)	Max	Min
	kW	33.76
Heat Output (P) (Non Condensing 70° C Mean Water Temp)	Max	Min
	kW	30.18
Heat Output (P) (Condensing 40° C Mean Water Temp)	Max	Min
	kW	32.61
Max Gas Rate (2H - G20 - 20mbar) (After 10 Mins)	kW Input	33.76
	m ³ /hr	3.4
Inlet Pressure at Gas Valve (Natural Gas)	Min	18.1 mbar
	Max	22.5 mbar
	(see Section 10.1)	
Injector (Natural Gas)	Diameter	6.5mm
	CO/CO² Ratio	0.001
NO_x Class	5	

Horizontal		
Flue Terminal	Diameter -	110mm
Dimensions	Projection -	150mm
Connections		
Gas Supply	-	15mm
Central Heating Flow	-	28mm
Central Heating Return	-	28mm
Condensate Drain (Pump)	-	10mm o.d.
Outercase Dimensions		
Casing Height	-	850mm
Casing Width	-	390mm
Casing Depth	-	520mm
Minimum Clearances		
(For unventilated compartments see Section 7.2)		
Both Sides	-	5mm
Above Casing	-	15mm
Above Casing		
Under fixed worktop - (It is recommended that any worktop is removable)	-	25mm
Front (For Servicing)	-	500mm
Front (In Operation)	-	5mm
Weights		kg
Packaged Boiler Carton	-	49.5
Packaged Flue Kit	-	3.6
Installation Lift Weight	-	37.5
Installed Weight (dry)	-	44.5
Recommended System		
Temperature Drop		20°C
Condensing		

Electrical Supply	230V~ 50Hz
The boiler must be connected to an earthed supply. A permanent and switched live are required. The boiler has a 4 wire connection.	
Power Consumption	80W
External Fuse Rating	3A
Internal Fuse Rating (BS 4265)	
Fuse	3.15 AT (PCB)
Electrical Protection	IPXX
Water Content	
litres	2.6
Static Head	
max	30 metres
min	1 metre
Low Head	0.2m min
System Detail	
Fully pumped open vented & sealed systems. No bypass required.	
Controls	
boiler thermostat, safety thermostat, flow switch, electronic flame sensing, temperature protection thermostat & condensate blockage and level sensors	
Boiler Flow Temperature (adjustable)	55° C to 78° C (± 5° C)
Condensate Pump	
Head	3 metres
Flow Rate	1.8 l/min
Connection	10mm o.d. (pipe supplied)

SEDBUK Declaration

The efficiency is 90.9%

This value is used in the UK Government's Standard Assessment Procedure (SAP) for energy rating of dwellings. The test data from which it has been calculated has been certified by 0087.

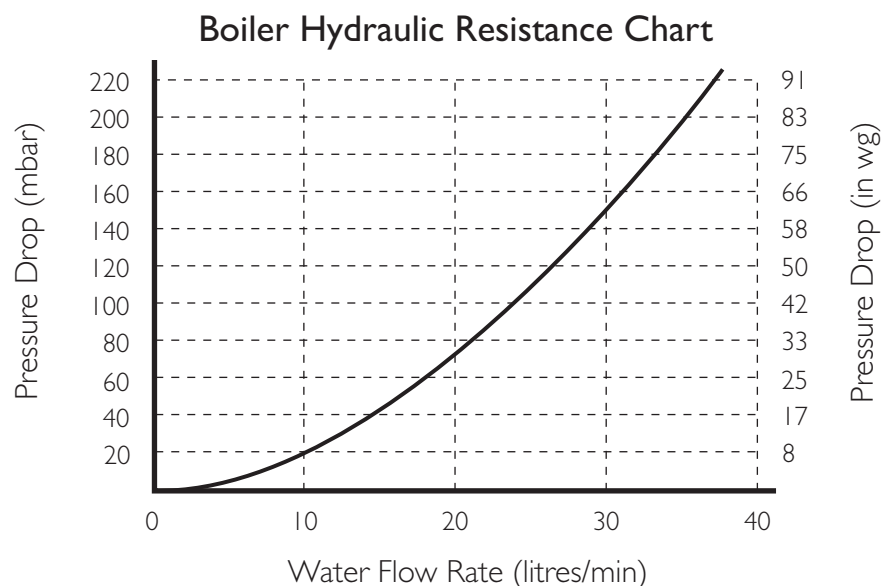

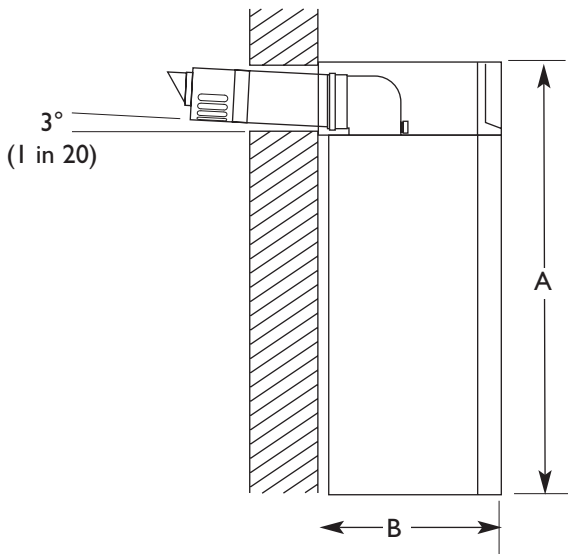

Fig. 7

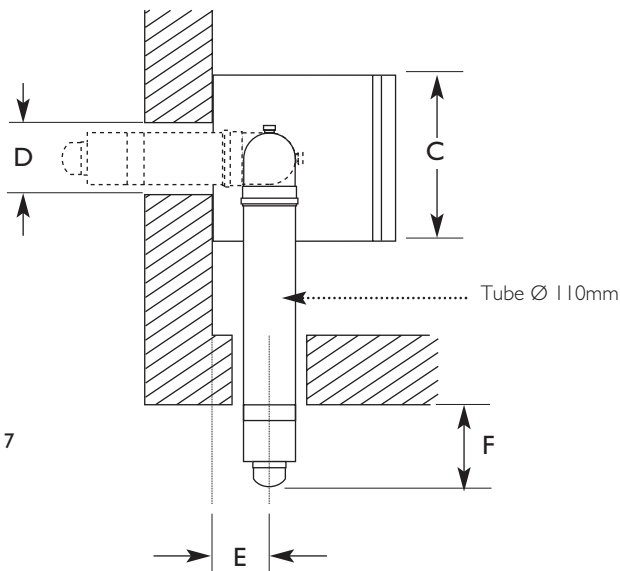
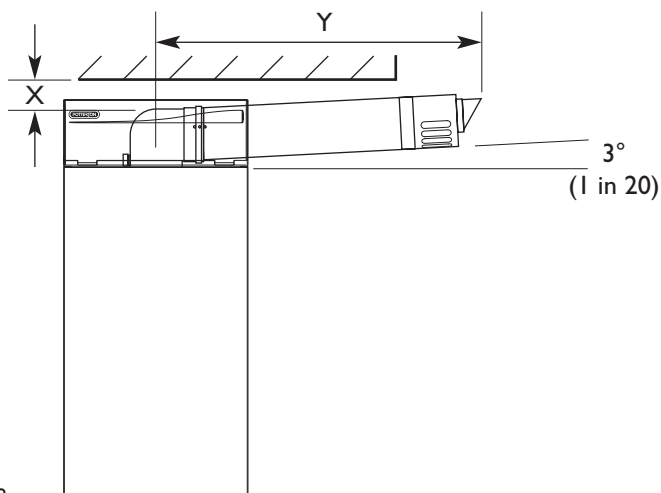

Fig. 8



DIMENSIONS

A	850mm
B	520mm
C	390mm
D	125mm Ø Min.
E	175mm
F	150mm

The 3° (1 in 20) fall provided by the elbow is to allow condensate to run back to the boiler, for discharge through the condensate disposal system.

SIDE FLUE (left and right)

For every 1m of horizontal flue length, the clearance above the top of the flue elbow should be 55mm to incorporate the 3° (1 in 20) fall in the flue from the terminal to the elbow. **It is especially important to consider this when fitting the boiler under a work top !**

Flue length (Y)	Clearance (X)
up to 1m	55mm
1m - 2m	110mm
2m - 3m	165mm
3m - 4m	220mm

6.1 Water Circulating Systems

1. The boiler is suitable for use with open vent fully pumped systems and sealed systems .

The following conditions should be observed on all systems:

- The static head must not exceed 30m of water.
- The boiler must not be used with a direct cylinder.
- Drain cocks should be fitted to all system low points.
- All gas and water pipes and electrical wiring must be installed in a way which would not restrict the servicing of the boiler.
- Position isolating valves as close to circulating pump as possible.

6.2 Treatment of Water Circulating Systems

- All recirculatory water systems will be subject to corrosion unless an appropriate water treatment is applied. This means that the efficiency of the system will deteriorate as corrosion sludge accumulates within the system, risking damage to pump and valves, boiler noise and circulation problems.
- When upgrading existing systems that exhibit evidence of sludging, it is advisable to clean the system prior to treatment in order to remove any sludge and reduce the likelihood of these deposits damaging new components.
- When fitting new systems flux will be evident within the system, which can lead to damage of system components.
- All systems must be thoroughly drained and flushed out. Using, for example Betz-Dearbon Sentinel X300 or X400 or Fernox Superfloc Universal Cleanser. They should be used following the flushing agent manufacturer's instructions.
- System additives - corrosion inhibitors and flushing agents/descalers should be suitable for aluminium and comply to BS7593 requirements, e.g. Betz-Dearbon Sentinel X100 and Fernox-Copal which should be used following the inhibitor manufacturer's instructions.

Failure to flush and add inhibitor to the system will invalidate the boiler warranty.

- It is important to check the inhibitor concentration after installation, system modification and at every service in accordance with the manufacturer's instructions. (Test kits are available from inhibitor stockists.)
- For information or advice regarding any of the above contact Technical Enquiries Tel. 08706 049 049

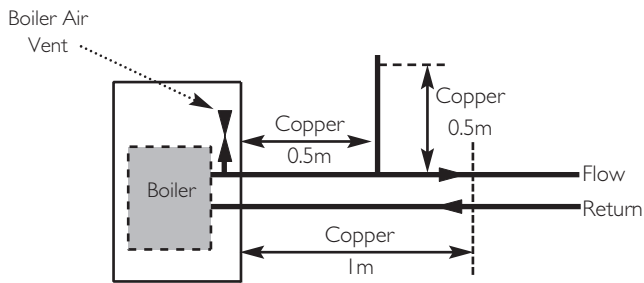

Fig. 9

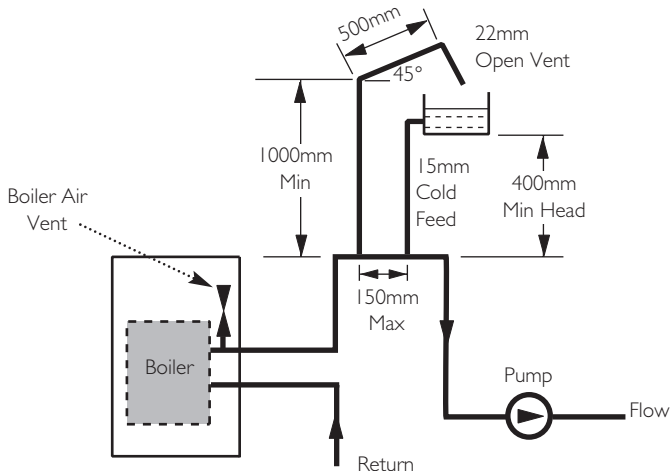

Fig. 10 Typical Low Head Installation

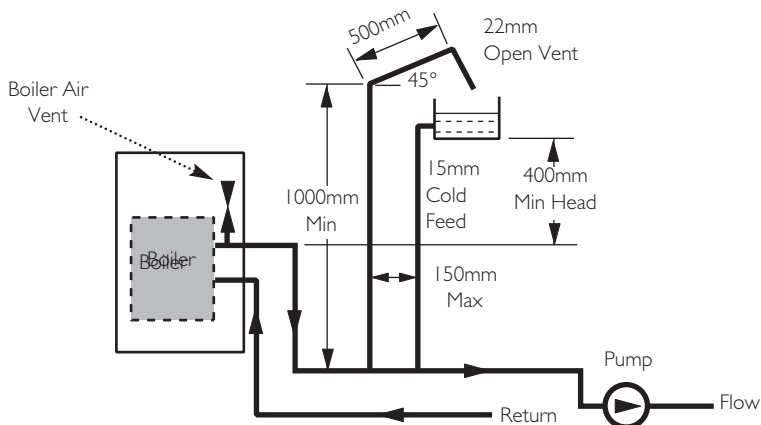

Fig. 11 If Conditions Require, This System Possible

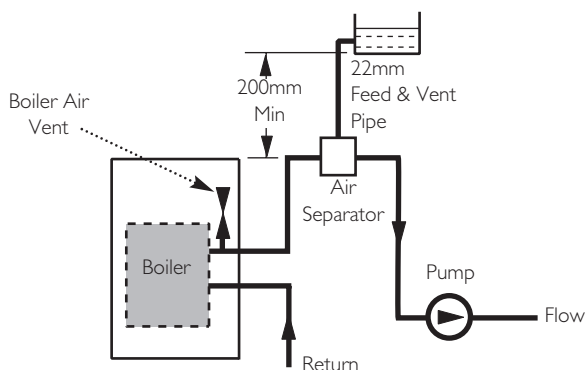

Fig. 12 Alternative Low Head Installation

6.0 System Details

6.3 Pipework

1. The sizes of flow and return pipes from the boiler should be determined by normal methods, according to the requirements of the system.
2. The connection tails for the boiler are 28mm diameter. The 28mm section of the tails can be cut back to 22mm if required.
3. The flow & return tails are push - fit 'O' ring and clip connections within the boiler case.
4. A 20 °C drop in temperature across the system is recommended for condensing boilers. Existing radiators may be oversized and so allow this, but where radiator sizing is marginal it may be advisable to retain a system temperature drop of 11 °C.
5. In systems using non-metallic pipework it is necessary to use copper pipe for the boiler Flow and Return. The copper must extend at least 1 metre from the boiler and include any branches (Fig. 9).

6. This boiler does not require a bypass.

6.4 Low Head Installation

1. Using a close couple arrangement the minimum head is as shown in the diagrams (Figs. 10 & 11) subject to the following conditions:
 - a) The pump being adjusted to give a 20°C drop across the boiler.
 - b) The pump must be fitted on the flow.
 - c) The pump must be fitted in accordance with the pump manufacturer's instructions.
 - d) The open vent pipe must be taken up from a tee in a horizontal section of the flow pipe.
2. For heads below 400mm then an alternative utilising a combined vent and feed pipe may be connected (Fig. 12). This must be a minimum of 22mm diameter. It is recommended that an air separator is fitted when using a combined feed and vent pipe.

6.5 Air Vents

For correct operation of the flow switch the boiler and system MUST be completely vented.

1. A manual air vent is fitted on the flow pipe, to enable complete venting of the boiler. The pipe access panel must be removed to do this.
2. Additional vents should be fitted at suitable points on the system as required.

Key to colours
 b - Blue
 br - Brown
 w - White
 o - Orange
 gr - Grey
 g/y - Green/Yellow

6.0 System Details

6.6 System Controls & Wiring

This boiler requires a permanent live for operation of the condensate pump and frost protection.

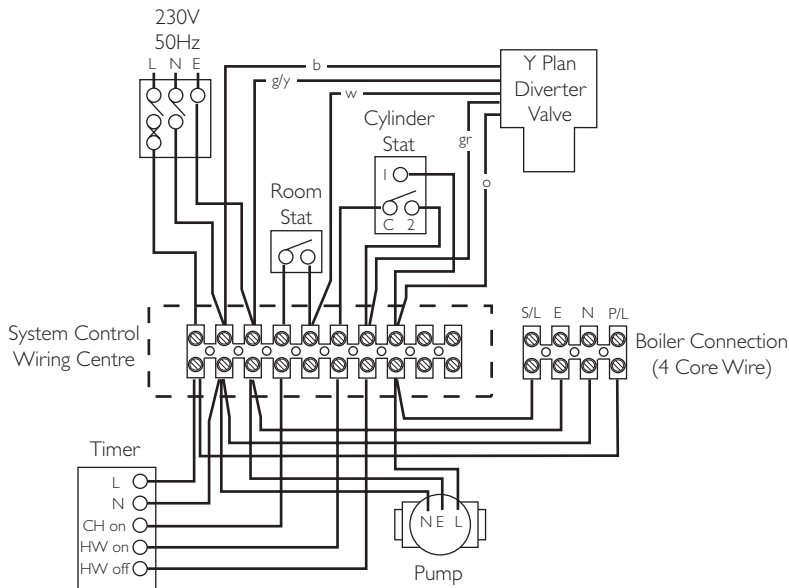

Y Plan, Room Thermostat System, CH Interlocked By Room Thermostat, DHW Interlocked By Cylinder Thermostat

At least the Radiator(s) near the Room Thermostat not TRV'd
 Pump run from Switched Live

1. To comply with Part L1 of the Building Regulations the heating system into which the boiler is installed should include the following:

- a) zone controls
- b) timing controls
- c) boiler control interlocks

2. Such a system needs to be fully pumped and must provide independent temperature and time control to both the heating and hot water circuits and have a boiler and system pump interlock.

3. The boiler should be controlled so that it operates on demand only. Where it is proposed to effect control by thermostatic radiator valves a room thermostat should also be provided to switch off the boiler when there is no demand for heating.

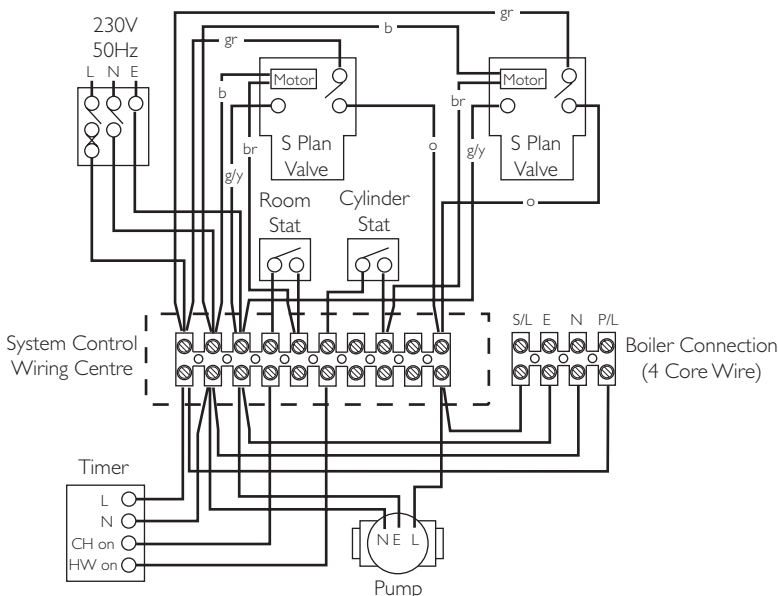

S Plan, Room Thermostat System, CH Interlocked By Room Thermostat, DHW Interlocked By Cylinder Thermostat

At least the Radiator(s) near the Room Thermostat not TRV'd
 Pump run from Switched Live

6.0 System Details

6.7 Sealed Systems (Fig. 13)

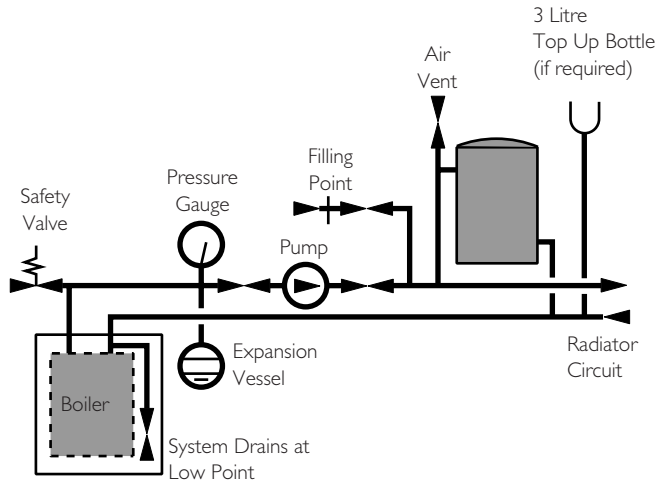

Fig. 13

Max Boiler Flow
Temp = 82° C

Method of determining minimum expansion vessel volume for sealed systems.

Vessel Charge Pressure (Bar)	Initial System Pressure (Bar)	Multiply Total Water Content Of System By (Litres)
0.5	0.5	0.067
	1.0	0.112
	1.5	0.207
	2.0	0.441
1.0	1.0	0.087
	1.5	0.152
	2.0	0.330
1.5	1.5	0.125
	2.0	0.265

Table. 1

Example :- System Volume = 75 litres
Vessel Charge Pressure = 1.0 bar
Initial System Pressure = 1.5 bar
Then :- $75 \times 0.152 = 11.4$ litres
Expansion Vessel Volume

NOTE

Where a vessel of the calculated size is not obtainable then the next available larger size should be used.

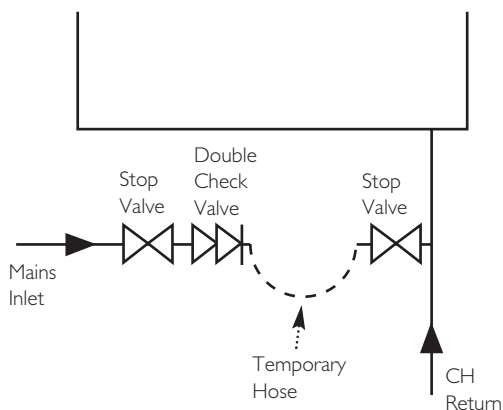

Fig. 14

1. **SAFETY VALVE** - A safety valve complying with the requirements of BS 6750 Part 1 must be fitted close to the boiler on the flow pipe by means of a horizontal or vertically upward connection with no intervening valve or restrictions and should be positioned to facilitate testing. The valve should be pre-set and non-adjustable to operate at a pressure of 3 bar (45 lbf/in²). It must be arranged to discharge any water or steam through a pipe to a safe outlet position.

2. **PRESSURE GAUGE** - A pressure gauge of minimum range 0-4 bar (0-60 lbf/in²) with a fill pressure indicator must be fitted to the system, preferably at the same point as the expansion vessel in an easily visible position.

3. **EXPANSION VESSEL** - An expansion vessel complying with the requirements of BS 4814 must be fitted to the system by means of a connection close to the inlet side of the circulating pump in accordance with the manufacturers instructions, the connecting pipe being unrestricted and not less than 15mm (1/2 in) nominal size. The volume of the vessel should be suitable for the system water content and the nitrogen or air charge pressure should not be less than the system static head (See Table. 1).

Further details of sealed system design can be obtained from BS 5449 and the British Gas publication entitled 'Specifications for Domestic Wet Central Heating Systems'.

4. **FILLING POINT** - A filling point connection on the central heating return pipework must be provided to facilitate initial filling and pressurising and also any subsequent water loss replacement / refilling. The sealed primary circuits may be filled or replenished by means of a temporary connection between the primary circuit and a supply pipe provided a 'Listed' double check valve or some other no less effective backflow prevention device is permanently connected at the inlet to the circuit and the temporary connection is removed after use. The filling method adopted must be in accordance with all relevant water supply regulations and use approved equipment.

Your attention is drawn to, for GB: Guidance G24.2 and recommendation R24.2 of the Water Regulations Guide. for IE: the current edition of I.S. 813 "Domestic Gas Installations".

5. **MAKE UP SYSTEM** - A method of replacing water lost from the system should be provided either by means of a make up vessel of not more than 3 litres (5 pints) capacity, mounted above the highest point of the system, or by re-pressurisation of the system.

6. **VENTING** - A method of venting the system during filling and commissioning must be provided by fitting automatic air vents or by venting manually.

7. **HOT WATER STORAGE** - The hot water storage vessel must be of the indirect coil type.

8. **COMPONENTS** - All components used in the system must be suitable for operation at 110°C (230°F) and at the pressure allowed by the safety valve.

7.0 Site Requirements

7.1 Location

NOTE: Due to the high efficiency of the boiler a plume of water vapour will be discharged from the flue. This should be taken into account when siting the flue terminal.

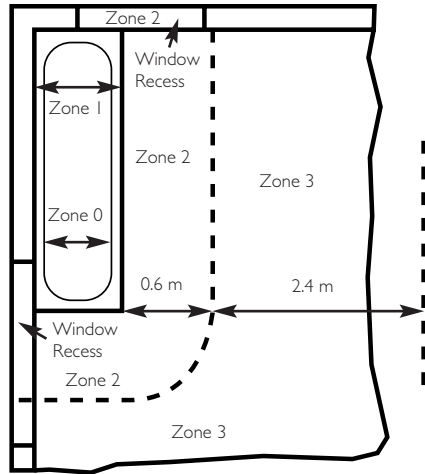

Fig. A (Applies in GB ONLY)

1. The boiler must be fitted on a suitable flat and level surface capable of supporting the weight. Any wall behind the boiler must be at 90° to the floor to allow case top cover to fit correctly.

2. The flue must pass through an outside wall or roof and discharge to atmosphere in a position permitting satisfactory removal of combustion products and providing an adequate air supply.

3. The boiler should be fitted within the building unless otherwise protected by a suitable enclosure i.e. garage or outhouse.

4. The boiler incorporates a frost protection device. This will only protect the boiler. To ensure protection of the system pipework and components it is recommended to incorporate an appropriate device within the system controls.

5. If the boiler is fitted in a room containing a bath or shower, it can only be fitted in Zone 3, (Figs. A & B shows zone dimensions for a bathtub. For other examples refer to Section 601 of the Current I.E.E. Wiring Regulations).

Reference must be made to the relevant requirements:-
In GB this is the current I.E.E. Wiring Regulations and Building Regulations.

In IE reference should be made to the current edition of I.S. 813 "Domestic Gas Installations" and the current ETCL rules.

6. If the boiler is to be fitted into a building of timber frame construction then reference must be made to the current edition of Institute of Gas Engineers Publication IGE/UP/7 (Gas Installations in Timber Framed Housing).

7.2 Compartment

1. Where the boiler is installed in a cupboard or compartment, no air vents are required for cooling purposes providing that the minimum dimensions below are maintained.

Width	400mm
Height	875mm
Depth	525mm

2. Any compartment should be large enough to house the boiler only.

NOTE: The ventilation label on the front of the outer case **MUST NOT BE REMOVED** when the boiler is installed in a compartment or cupboard.

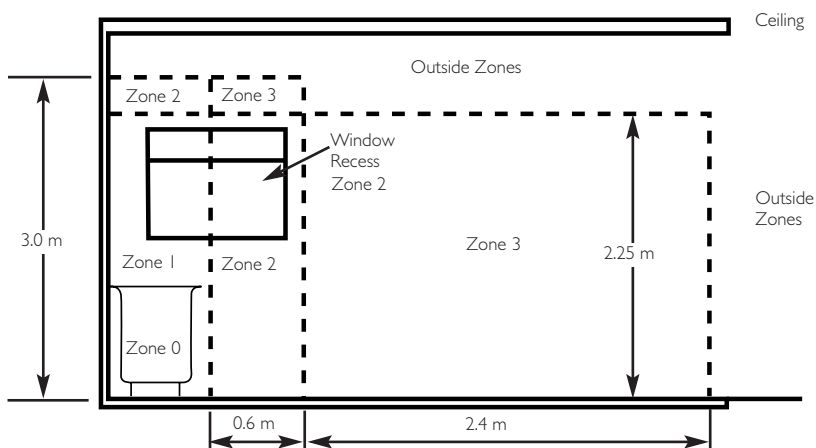

Fig. B (Applies in GB ONLY)

7.0 Site Requirements

7.3 Clearances (Figs. 15 & 16)

1. These dimensions include the necessary clearances around the boiler for case removal, spanner access and air movement. Additional clearances may be required for the passage of pipes around local obstructions such as joists running parallel to the front face of the boiler. For side flue installations also See Section 8.1, Figs. 20 & 21.

2. It is recommended that any worktop is removable for servicing access.

7.4 Gas Supply

1. Check that the information concerning the state of adjustment given on the data plate is compatible with local supply conditions.

2. The gas installation should be in accordance with the relevant standards. In GB this is BS 6891. In IE this is the current edition of I.S. 813 "Domestic Gas Installations".

3. The connection to the boiler is a 15mm tail on the gas service cock. The tail protrudes through the boiler rear panel and is protected by a transit bracket which may be removed to aid connection.

4. Ensure that the pipework from the meter to the boiler is of adequate size. (If the boiler is further than 3 metres from the Gas Meter 22mm pipe should be used). **Do not use pipes of a smaller diameter than the boiler gas connection.**

7.5 Electrical Supply

1. External wiring must be correctly earthed, polarised and in accordance with relevant regulations/rules. In GB this is the current I.E.E. Wiring Regulations. In IE reference should be made to the current edition of ETCL rules.

2. The mains supply is 230V ~ 50Hz fused at 3A.

NOTE: "The method of connection to the electricity supply must facilitate complete electrical isolation of the appliance and system".

Connection may be via a fused double-pole isolator with a contact separation of at least 3mm in all poles, **which must be in an accessible position to the user** and serve the boiler and system controls only.

There is no method of isolating the boiler at the user interface.

3. Four core cable is required to supply the boiler as a permanent live is necessary for the operation of the condensate pump and frost protection.

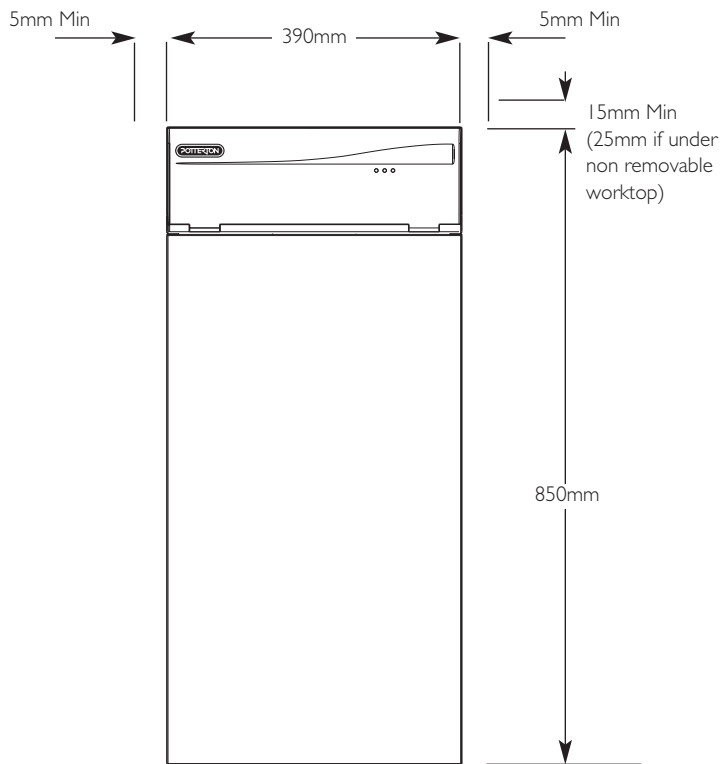

Fig. 15

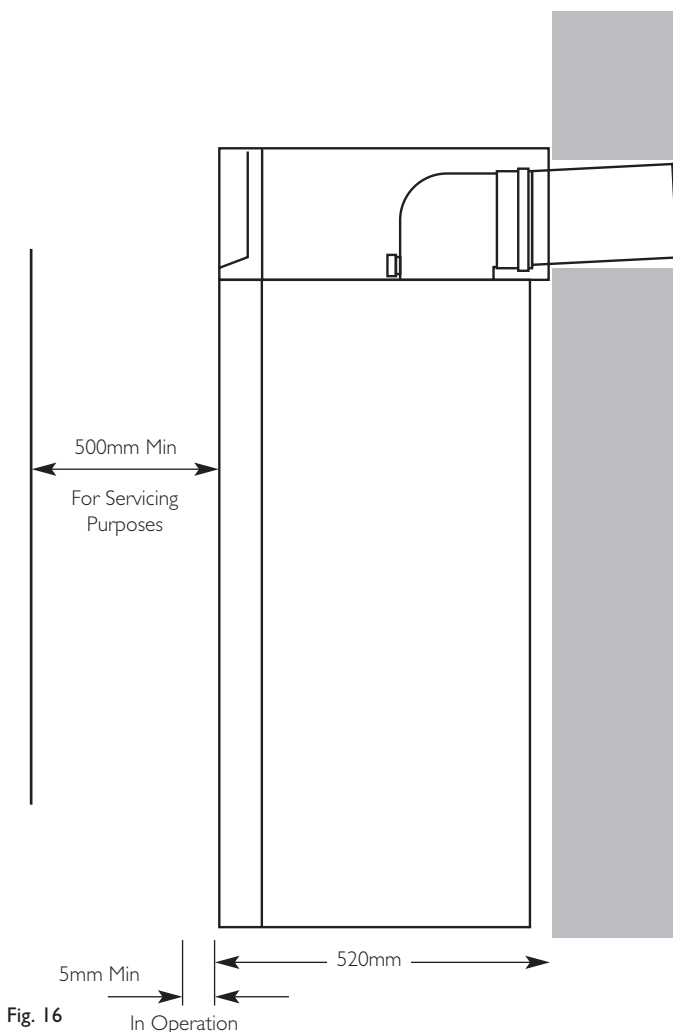

Fig. 16

7.0 Site Requirements

7.6 Condensate Drain - General

Failure to install the condensate discharge pipework correctly will affect the reliable operation of the boiler.

1. Ensure the discharge of condensate complies with any national or local regulations in force.
BS 6798:2000 & Part H1 of the Building Regulations give further guidance.
2. If any further drain pipe is required (additional to that supplied with the boiler), it should be run in a proprietary material e.g. PVC, PVC-U, ABS, PVC-C or PP.
3. Metal pipework is NOT suitable for use in condensate discharge systems.
4. Any pipe fitted externally must be kept as short as possible to minimise the potential of freezing and must be insulated using waterproof material.
5. When discharging condensate into a soil stack or waste pipe the effects of existing plumbing must be considered.

7.7 Condensate Disposal

1. This boiler incorporates an automatic pumped condensate system. See the graph opposite for available pump flow rates.
2. 3.5 metres of flexible 10mm PVC pipe are supplied with the boiler. 0.5 metres of this length remains coiled within the boiler to allow removal of the pump assembly. This must not be uncoiled to provide extra length.
3. A fitting and securing clip (Fig. B) to accept the 10mm PVC pipe and connect to 21.5mm overflow pipe is also supplied.
4. The 10mm pipe can be routed to a maximum of 3 metres vertically and then discharge via gravity or be routed horizontally (Fig. A). A combination of vertical and horizontal runs is permissible.
5. The pipe must be supported, either using suitably spaced clips or run within larger diameter pipe. When using clips take care not to deform the pipe.
6. When routing the pipe through a wall it must be suitably sleeved. Also the pipe must not be exposed to sources of heat, and should be protected in locations where it may be damaged.
7. The pipe should be routed so that any sharp bends, dips and loops are avoided. A minimum radius of 100mm is recommended for any bends. No slope is necessary and air breaks are not required on the pumped part of the condensate run.
8. If the boiler is fitted in an unheated location the entire length of condensate pipe should be treated as external, and run within insulated larger diameter pipe.

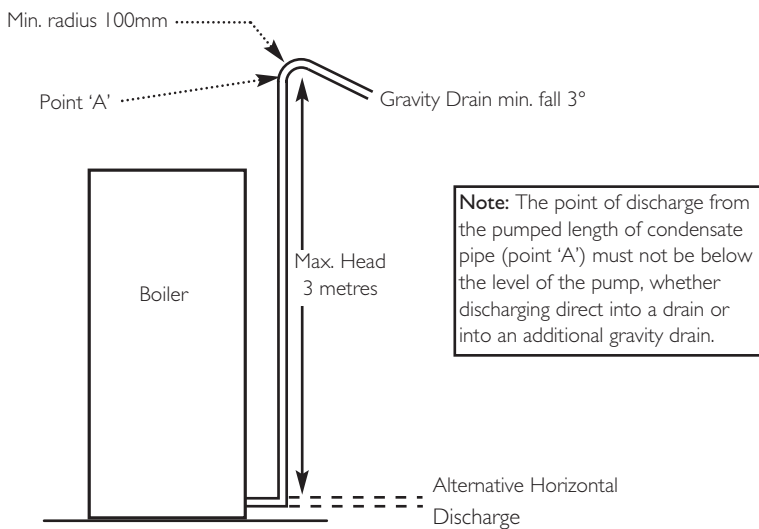
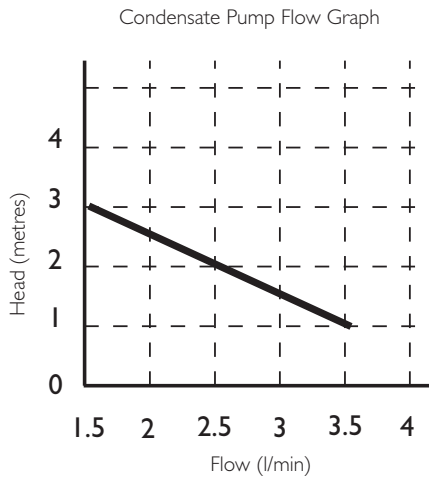

Fig. A

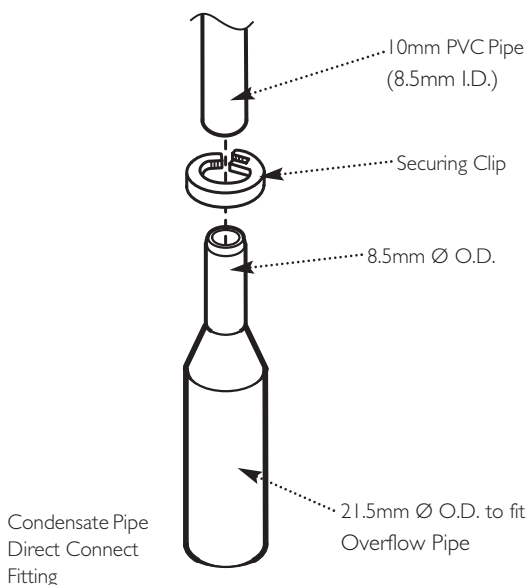

Fig. B

7.0 Site Requirement

7.7 Condensate Disposal (cont.)

9. Ensure that the condensate can discharge freely (without blockage or restriction of the pipe) into the drain.

10. Examples are shown of condensate pipe methods of termination:-

- i) via an internal discharge branch (e.g. sink waste) - Fig. C.
- ii) to an internal or external soil and vent pipe - Fig. D.
- iii) to a drain or gully - Fig. E. Ensure that the condensate can discharge freely (without blockage or restriction of the pipe) into the drain.
- iv) to a soakaway - Fig. F.

Termination via internal discharge branch e.g. sink waste - downstream

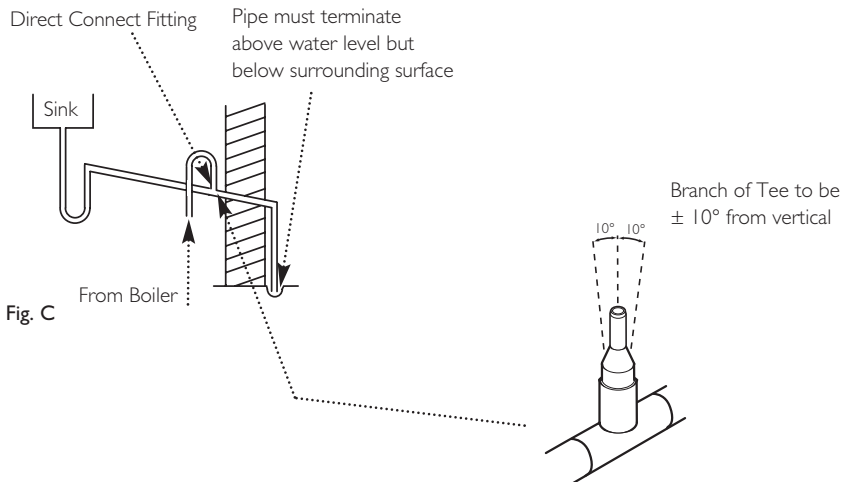

Termination to an internal soil and vent pipe

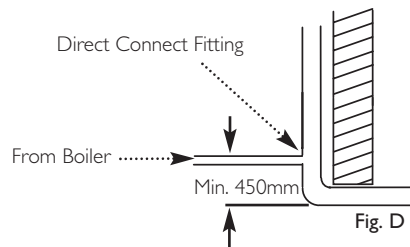

Termination to a drain or gully

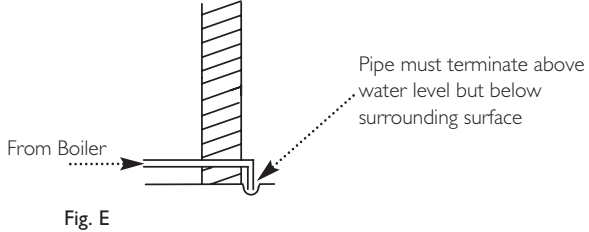

Termination to a purpose made soak-away

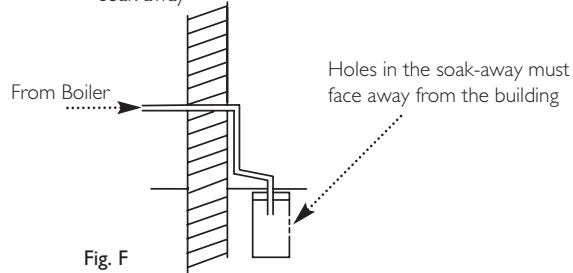

7.0 Site Requirements

7.8 Flue

NOTE: Due to the high efficiency of the boiler a plume of water vapour will be discharged from the flue. This should be taken into account when siting the flue terminal.

1. The following guidelines indicate the general requirements for siting balanced flue terminals. For GB recommendations are given in BS 5440 Pt. I. For IE recommendations are given in the current edition of I.S. 813 "Domestic Gas Installations".

2. If the terminal discharges onto a pathway or passageway, check that combustion products will not cause a nuisance and that the terminal will not obstruct the passageway.

3. When siting the flue take into consideration the effect the plume of water vapour may have on neighbours .

4. Adjacent surfaces close to the flue terminal may need protection from the effects of condensation. Alternatively a flue deflector kit (part no. 248167) is available.

5. For installation of the flue into an internal corner at the 25mm dimension the flue plume deflector kit (part no. 248167) must be fitted.

6. * Reduction to the boundary is possible down to 25mm but the flue plume deflector kit (part no. 248167) must be fitted.

7. If a terminal is less than 2 metres above a balcony, above ground or above a flat roof to which people have access, then a suitable terminal guard must be provided.

8. If required a suitable terminal guard (part no. 248484) is available from Baxi for use with the flue deflector. See also Section 7.1.1.

9. For fitting under low soffits and eaves it is acceptable for the flue to project up to 500mm from the face of the wall to the inside of the air intake. This can be painted if required using a suitable external paint.

Terminal Position with Minimum Distance (Fig. 17) (mm)

A ^a	Directly below an opening, air brick, opening windows, etc.	300
B ^a	Above an opening, air brick, opening window etc.	300
C ^a	Horizontally to an opening, air brick, opening window etc.	300
D	Below gutters, soil pipes or drain pipes.	25
E	Below eaves.	25
F	Below balconies or car port roof.	25
G	From a vertical drain pipe or soil pipe.	25
H	From an internal (i) or external (ii) corner.	(i) 25 (ii) 115
I	Above ground, roof or balcony level.	300
J	From a surface or boundary line facing a terminal.	600
K	From a terminal facing a terminal (Horizontal flue).	1200
	From a terminal facing a terminal (Vertical flue).	600
L	From an opening in carport (e.g. door, window) into the dwelling.	1200
M	Vertically from a terminal on the same wall.	1500
N	Horizontally from a terminal on the same wall.	300
R	From adjacent wall to flue (vertical only).	300
S	From an adjacent opening window (vertical only).	1000

Table. 2

^a In addition, the terminal should be no nearer than 150 mm to an opening in the building fabric formed for the purpose of accommodating a built-in element such as a window frame. See BS 5440 Pt. I.

NOTE: The distance from a fanned draught boiler terminal installed parallel to a boundary may not be less than 300mm* in accordance with the diagram below, unless the flue deflector kit is used (see 7.7.6 opposite)

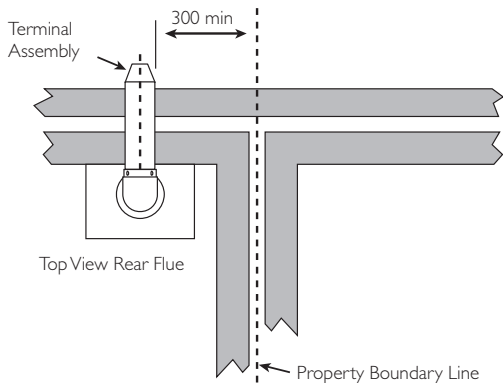

Fig. 16a

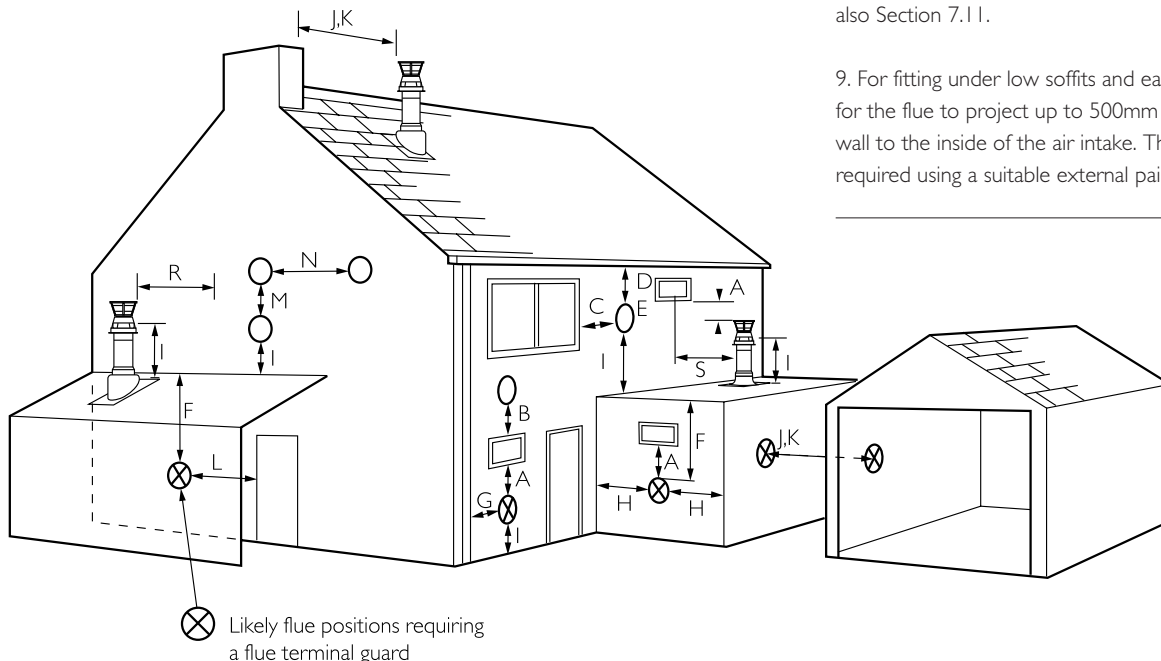

Fig. 17

7.0 Site Requirements

7.10 Standard Flue Dimensions

The standard horizontal flue kit allows for flue lengths between 270mm and 800mm from elbow to terminal (Fig. 18).

The maximum permissible equivalent concentric flue length is: 4 metres (Fig. 18a).

NOTE: Each additional 45° flue bend will account for an equivalent flue length of 0.5m.
eg. 45° = 0.5m, 93° = 2 x 45° = 1m etc.

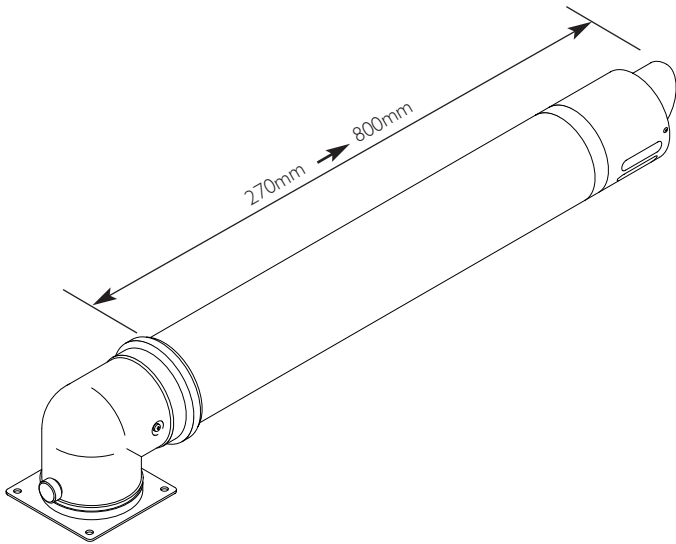

Fig. 18

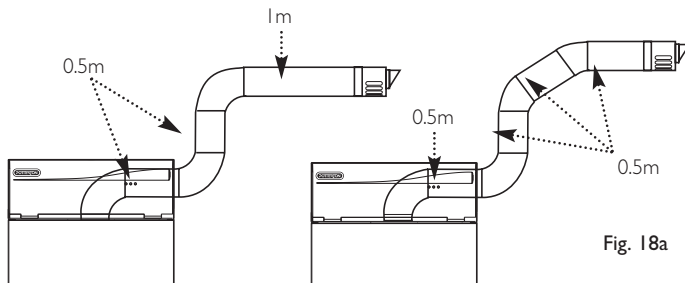

Fig. 18a

Pictorial examples of flue runs where EQUIVALENT flue length equals 4m

7.11 Terminal Guard (Fig. 19)

1. When codes of practice dictate the use of terminal guards, they can be obtained from most Plumbers' and Builders' Merchants.

2. When ordering a terminal guard, quote the boiler model name and type. Tower Flue Components (Tel. 01732 351555) part no. CGDK6BR is suitable.

3. There must be a clearance of at least 50mm between any part of the terminal and the guard. The guard should be positioned centrally over the terminal and fixed as illustrated.

4. The guard must be of a non - corrosive material (e.g. stainless steel) or plastic coated.

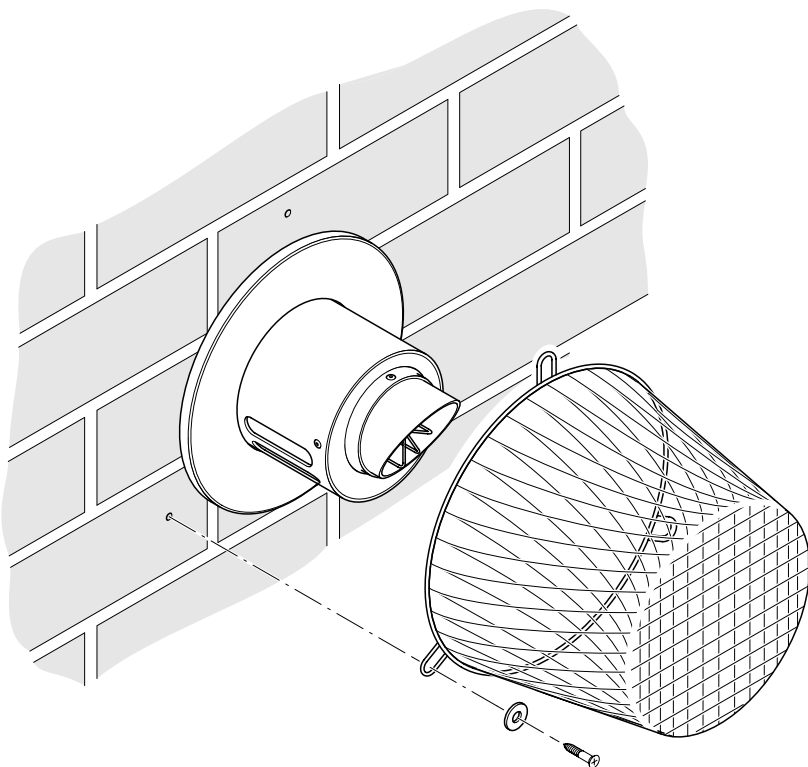

Fig. 19

7.0 Site Requirement

7.12 Flue options

Only a flue approved with the Potterton Promax FSB 30 HE Plus can be used.

Concentric

The maximum equivalent length is 4m horizontal or vertical. This does not include the standard elbow and flue/terminal assembly (horizontal) and terminal assembly (vertical).

Twin Flue

The total maximum equivalent flue length is 150m.

NOTE: Each 1m of flue duct should be calculated as 2m.

Any additional "in line" bends in the flue system must be taken into consideration. Their equivalent lengths are:

Concentric Pipes:	45° bend	0.5 m
	93° bend	1.0 m
Twin Flue Pipe:	45° bend (air duct)	1.3 m
	45° bend (flue duct)	2.6 m
	90° bend (air duct)	4.8 m
	90° bend (flue duct)	9.6 m

Detailed examples of equivalent flue length calculation are given in the Installation Guidance Notes for each flue system type.

(Documents 243501 and 243502 for concentric and twin pipe respectively).

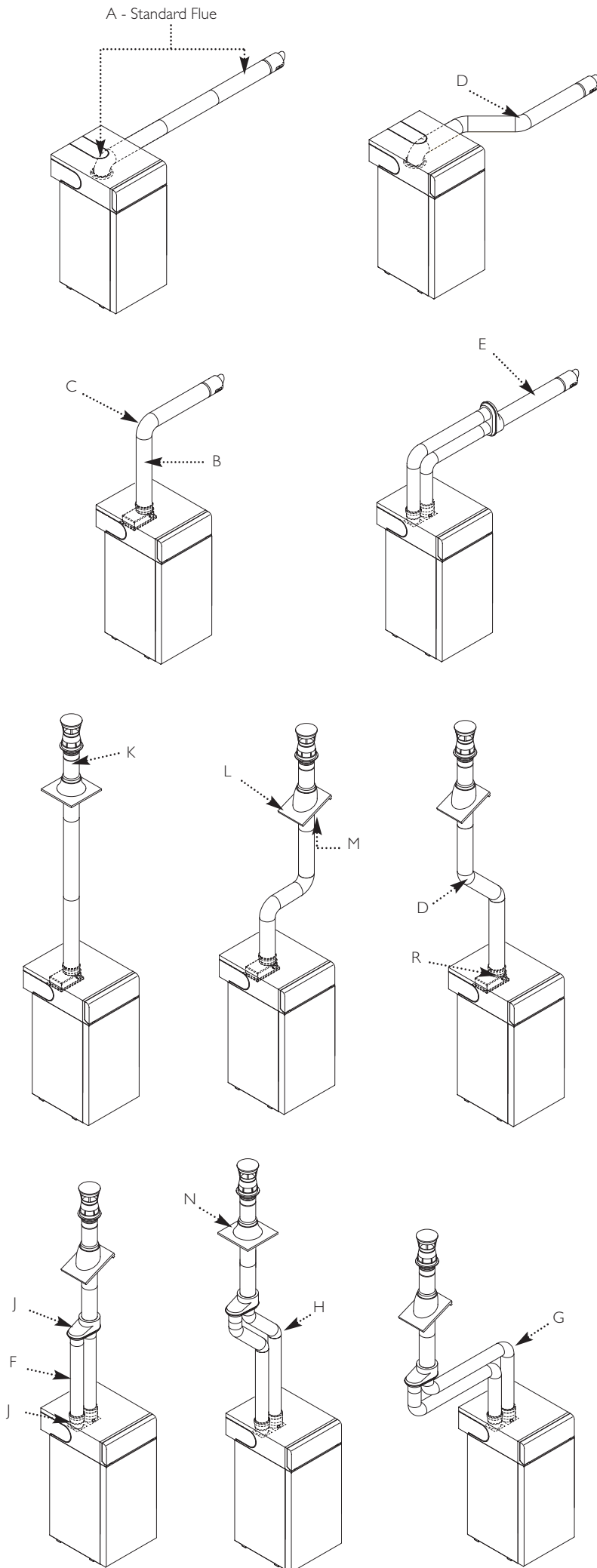

Key	Accessory	Size	Part Number
Concentric Flue System 110mm diameter			
A	Horizontal flue kit	850mm	236921
B	Straight extension kit	1000mm	241695
		500mm	241694
		250mm	241692
C	Bend kit	93°	241687
D	Bend kit (pair)	45°	241689
E	Horizontal flue terminal		243013BAX
	Clamp	110mm	243014BAX
Not Shown:-			
	Flue Plume Deflector		248167
	Terminal Guard (suitable for use with above)		248484
Twin Flue System 80mm diameter			
F	Straight extension kit	1000mm	238690
		500mm	238692
		250mm	238694
G	Bend kit	90°	246139
H	Bend kit (pair)	45°	246138
J	Twin flue adaptor kit		242757
Universal Vertical Flue Kits			
K	Vertical flue terminal		242802
L	Universal roof tile	25°/50°	243015
M	Roof cover plate kit		243131
N	Flat roof flashing		243016BAX
R	Vertical flue adaptor (concentric)		5106888
	Clamp	80mm	238684

8.0 Installation

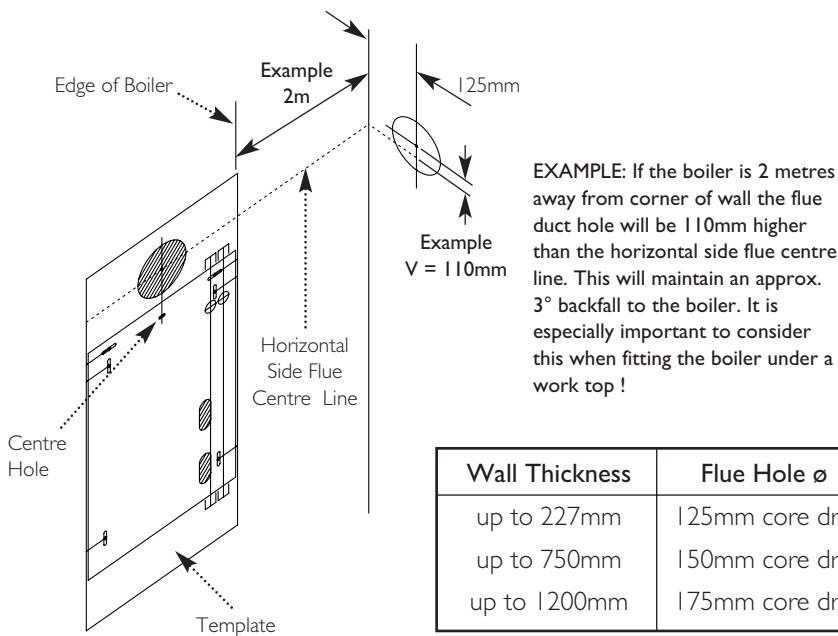

Fig. 20

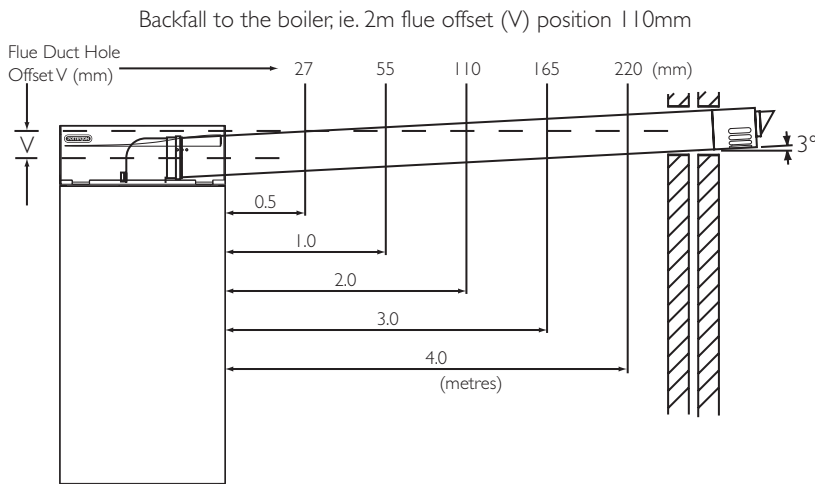

Fig. 21

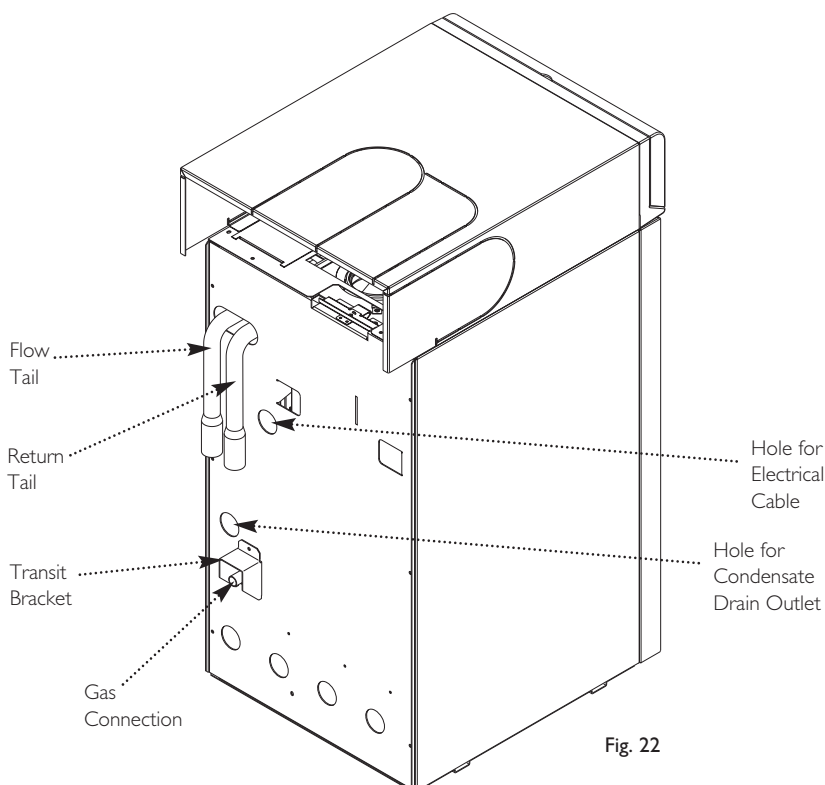

Fig. 22

Check Site Requirements before commencing.

8.1 Initial Preparation & Installation

1. Remove the outer carton.
2. For the boiler to operate correctly it must be level in both planes. Place the fixing template in the proposed boiler position ensuring that it is level.
3. Mark the centre of the flue hole (rear exit).
For side exit: project the horizontal side flue centre line into the corner of the room and along the wall to where the flue hole will be drilled. (Fig. 20). The diagram (Fig. 21) shows the dimensions required to ensure any horizontal flue is installed with the correct fall to the boiler. Mark the offset (V) dimension and if required, mark the position of the gas, water and condensate pipes. Remove the template.

4. Cut the hole for the flue (minimum diameter 125mm, see table (Fig. 20) for wall thicknesses and flue hole diameters).

5. Complete any pipework and wiring that will be inaccessible once the boiler is in position.

6. Undo the securing screws and remove the fascia, front door panel and top panel (see Figs. 1 & 2 on page 6). Remove the securing screw and disengage the pipe access panel.

8.2 Making the Water Connections

1. If desired the flow and return tails supplied with the boiler can be fitted at this stage and secured with the spring clips. The flow and return connections are identified on the boiler rear panel. The flow pipe incorporates a manual air vent.

2. Note that the seal is made by use of an 'O' ring, therefore some pipe movement will be evident even though a water tight seal has been achieved. Excessive force could result in damage to the connection.

3. Make all soldered joints before connecting the tails to the boiler to avoid damaging the 'O' rings.

4. Refit the pipe access panel.

8.3 Making the Gas Connection

1. The connection to the boiler is a 15mm tail on the gas service cock. The tail protrudes through the boiler rear panel and is protected by a transit bracket which may be removed to aid connection (see Fig. 22).

2. If solder joints are being used for the gas connection, remove the gas tap from the valve as excessive heat may damage the 'O' ring seal.

8.4 Priming the Condensate Trap

1. Using a funnel and tube, carefully pour approximately 1 cupful (250ml) of tap water into the flue products exhaust at the terminal or flue elbow sampling point to ensure a seal is made in the trap.

8.0 Installation

8.5 Fitting the Standard Flue

IMPORTANT: The flue should always be installed with a 3° (1 in 20) fall from terminal to elbow, to allow condensate to run back to the boiler.

1. The standard flue is suitable for lengths 270mm minimum to 800mm maximum (measured from the edge of the flue elbow outlet).

Rear Flue: maximum wall thickness - 575mm

Side Flue: maximum wall thickness - 535mm

2. **For rear exit** - measure the wall thickness (Fig. 26) and to this dimension add 270mm. This dimension to be known as (X).

i.e. (X) = wall thickness + 270

3. Take the flue and mark off (X) from the terminal end as indicated in the diagram (Fig. 27).

4. **For side exit** - measure the distance from the edge of the boiler case to the inner face of the wall (Fig. 26) and to this dimension add the wall thickness + 280mm. This dimension to be known as (Z).

i.e. (Z) = case to wall + wall thickness + 280

5. Take the flue and mark off (Z) from the terminal end as indicated (Fig. 27).

Before cutting check your dimensions !

6. The flue tubes are fixed together. Cut through both tubes whilst resting the flue on the semi-circular packing pieces. Deburr both tube ends.

NOTE: When cutting ensure the cut does not interfere with the inner flue support bracket (Fig. 27a).

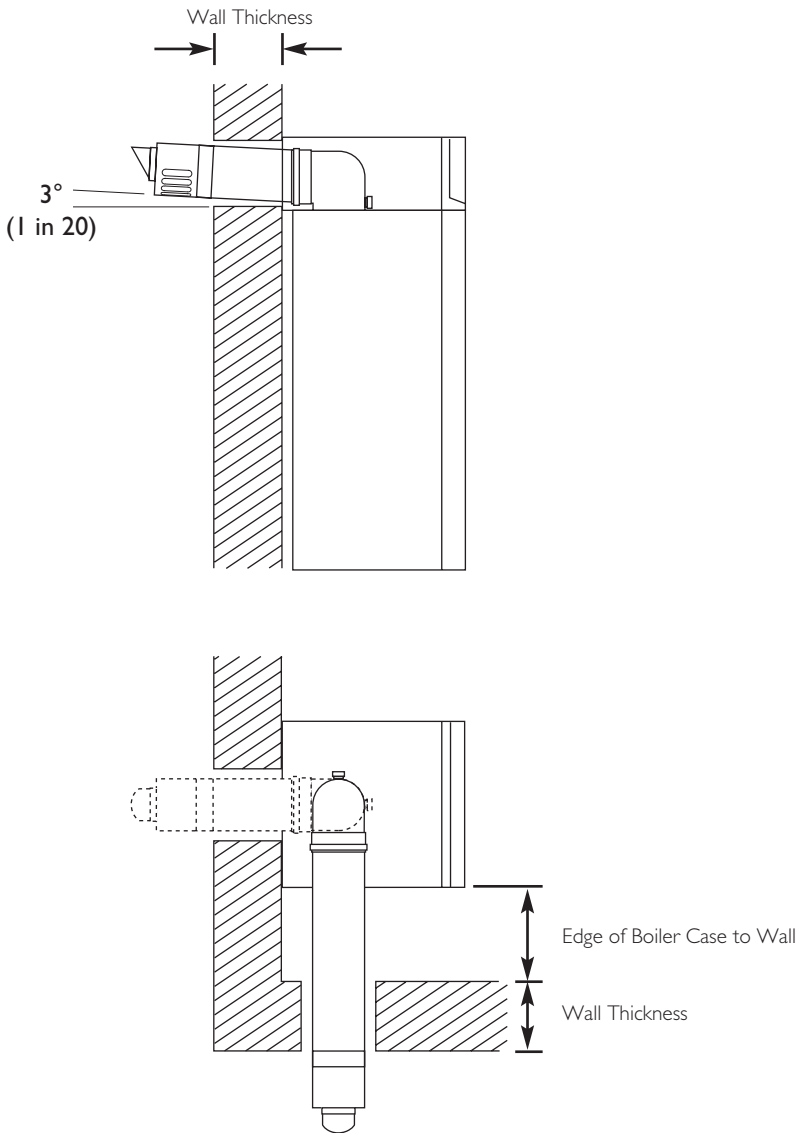

Fig. 26

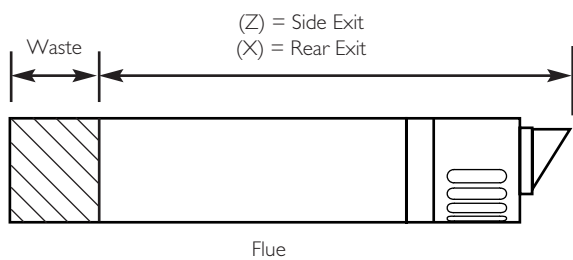

Fig. 27

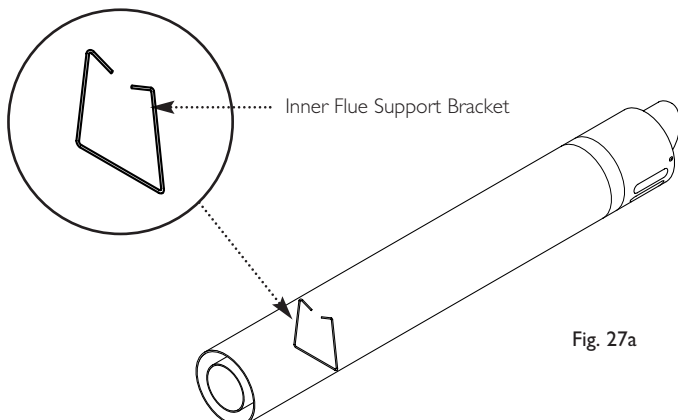

Fig. 27a

8.0 Installation

8.5 Fitting the Standard Flue (Cont)

7. Ensure the inner flue support bracket is positioned in the flue (Fig. 28).

8. Engage the flue into the flue elbow using soap solution to ease the engagement, ensuring the flue terminal is positioned as shown (Fig. 29).

9. Place the gasket over the flue exit on the boiler.

10. Slide the flue assembly through the hole in the wall.

11. Engage the elbow on to the flue connection on top of the boiler. Secure with the four screws supplied in the kit.

12. Make good between the wall and air duct outside the building ensuring the 3° drop between the terminal and elbow.

13. The flue trim should be fitted once the installation is complete and the flue secure (Fig. 30). Apply a suitable mastic to the inside of the trim and press against the wall finish, making sure the brickwork is dust free and dry.

14. If necessary fit a flue plume deflector kit and/or terminal guard (see Sections 7.6 & 7.11).

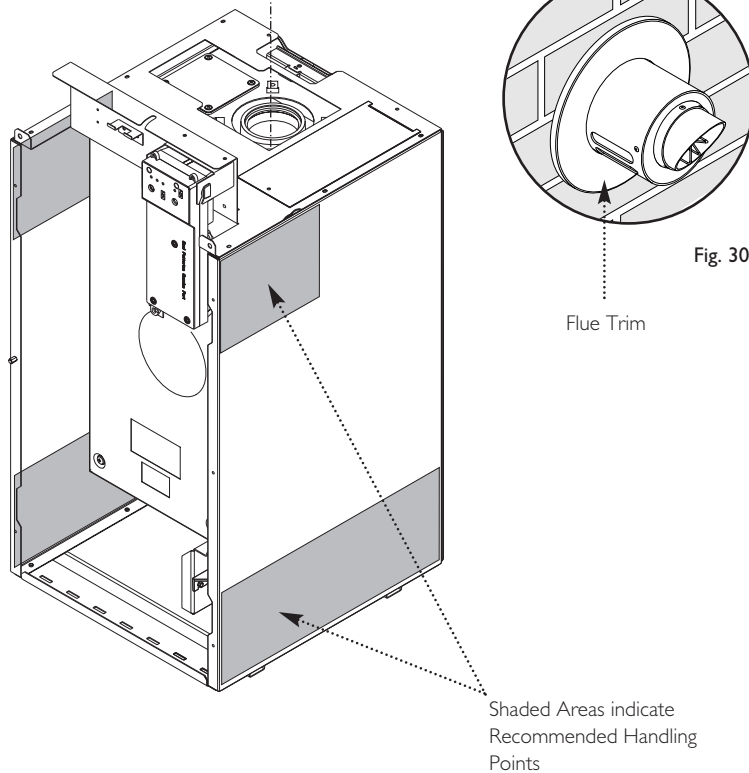
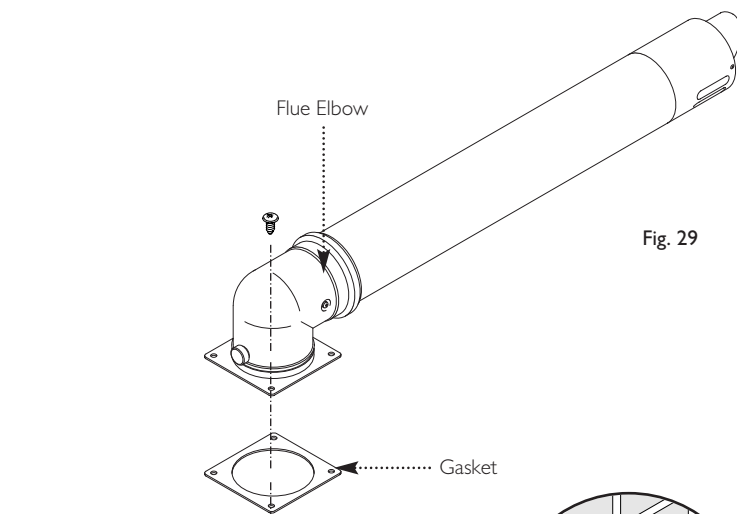
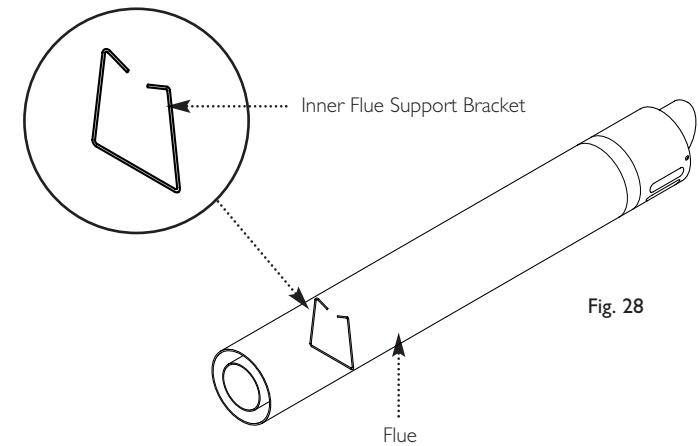

8.0 Installation

8.6 Making the Condensate Drain Connection

1. 3.5 metres of flexible 10mm PVC pipe are supplied with the boiler, ready connected to the pump. 0.5 metres of this length remains coiled within the boiler to allow removal of the pump assembly. This must not be uncoiled to provide extra length.

2. A fitting and securing clip (Fig. B) to accept the 10mm PVC pipe and connect to 21.5mm overflow pipe is also supplied. When using this fitting to connect to a 21.5mm overflow tee piece the branch must be vertical $\pm 10^\circ$ (Fig. C).

3. Feed the pipe through the grommet in the rear panel and connect to the drain system.

4. The 10mm pipe can be routed to a maximum of 3 metres vertically and then discharge via gravity or be routed horizontally (Fig. A). A combination of vertical and horizontal runs is permissible.

5. The pipe must be supported, either using suitably spaced clips or run within larger diameter pipe. When using clips take care not to deform the pipe.

6. When routing the pipe through a wall it must be suitably sleeved. Also the pipe must not be exposed to sources of heat, and should be protected in locations where it may be damaged.

7. The pipe should be routed so that any sharp bends, dips and loops are avoided. A minimum radius of 100mm is recommended for any bends. No slope is necessary and air breaks are not required on the pumped part of the condensate run.

8. If the boiler is fitted in an unheated location the entire length of condensate pipe should be treated as external, and run within insulated larger diameter pipe.

9. Ensure that the condensate can discharge freely (without blockage or restriction of the pipe) into the drain.

10. Examples are shown of condensate pipe methods of termination:-

- i) via an internal discharge branch (e.g. sink waste) - Fig. B.
- ii) to an internal or external soil and vent pipe - Fig. C.
- iii) to a drain or gully - Fig. D. Ensure that the condensate can discharge freely (without blockage or restriction of the pipe) into the drain.
- iv) to a soakaway - Fig. E.

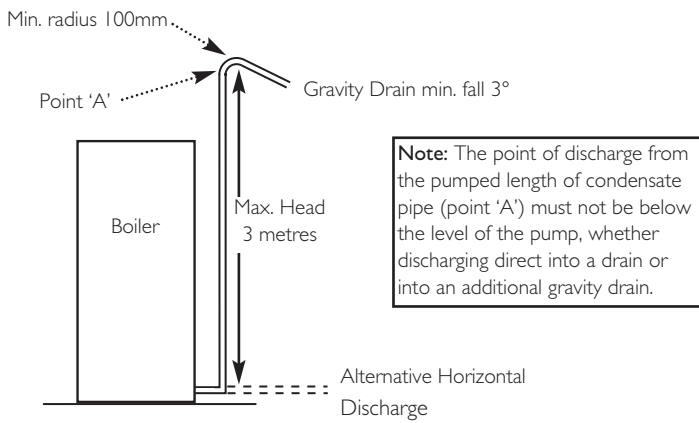

Fig. A

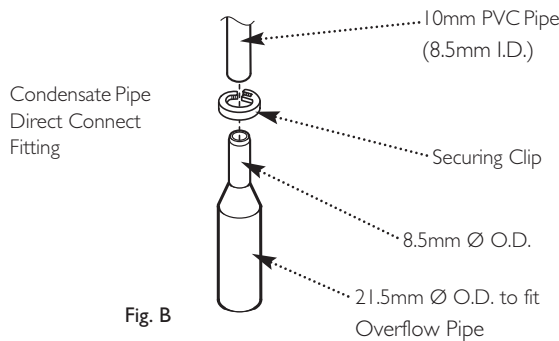

Fig. B

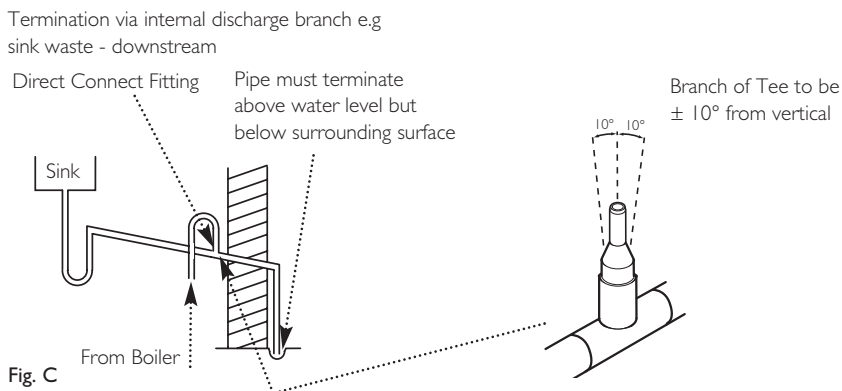

Fig. C

Termination to an internal soil and vent pipe

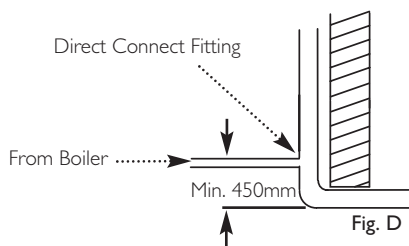

Fig. D

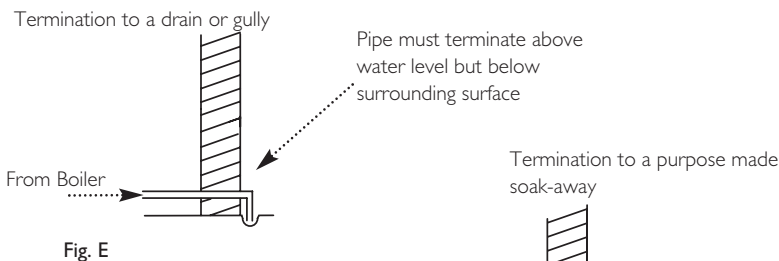

Fig. E

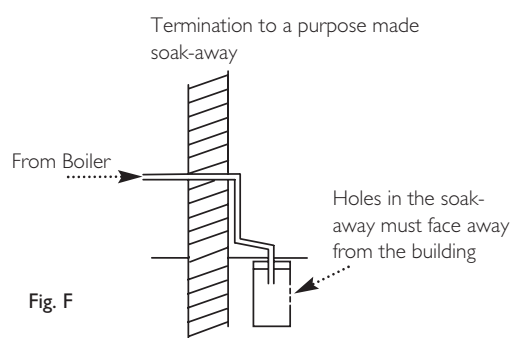

Fig. F

8.0 Installation

8.7 Making The Electrical Connections

WARNING: This boiler must be earthed

IMPORTANT: Four core cable is required to supply the boiler as a permanent live is necessary for the operation of the condensate pump and frost protection.

1. The electrical connections are on the right hand side of the boiler. Depending upon the nature of the installation it may be preferable to wire up to the boiler first before manoeuvring into position.

2. Undo the two screws securing the cable clamp and place to one side (Fig. 31).

3. Route the incoming electrical cable(s) from the system control wiring centre through the grommet in rear of the boiler and the grommet in the support bracket. This will prevent damage to the cable(s).

4. Lay the cable through the cable clamp to gauge the length of wire required when it is connected to the 4-way terminal block.

5. Connect the (S/L), (\oplus), (N) and (P/L) wires to the 4-way terminal block (Fig. 33) and refit the cable clamp (Fig. 31).

INTEGRAL PROGRAMMER

6. If the optional integral programmer is being fitted it can be done at this stage. Consult the instructions supplied in the programmer kit.

7. Check the electrical installation for; earth continuity, short circuits, resistance to earth, correct polarity and fuse rating.

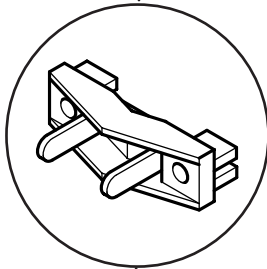
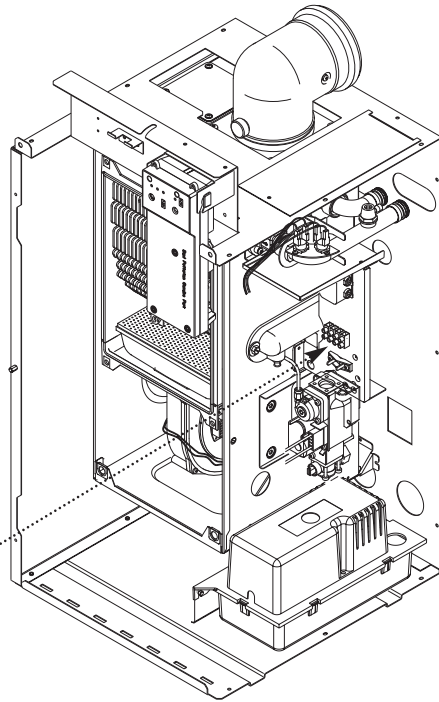

Cable Clamp

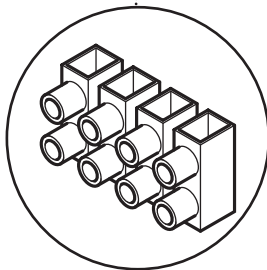

4-way Terminal Block

Fig. 31

Fig. 32

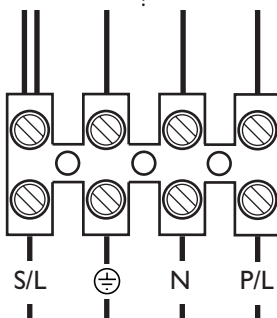
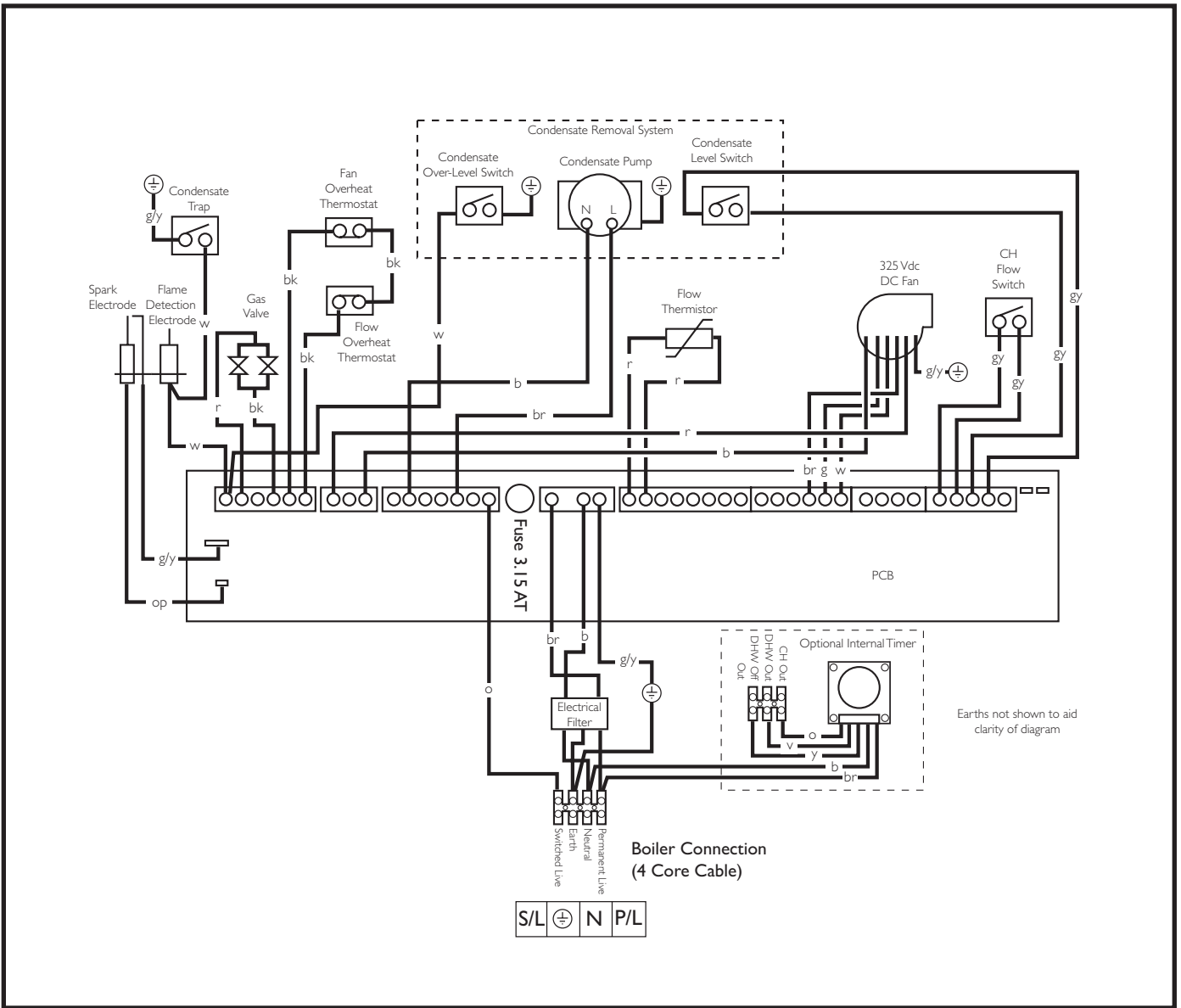

Fig. 33

Wiring from System Controls	
S/L	Switched Live
\oplus	Earth
N	Neutral
P/L	Permanent Live



Key To Wiring Colours

- | | |
|------------|-------------------|
| b - Blue | r - Red |
| bk - Black | g - Green |
| w - White | g/y- Green/Yellow |
| br - Brown | op - Opaque |
| gy - Grey | y - Yellow |
| o - Orange | v - Violet |

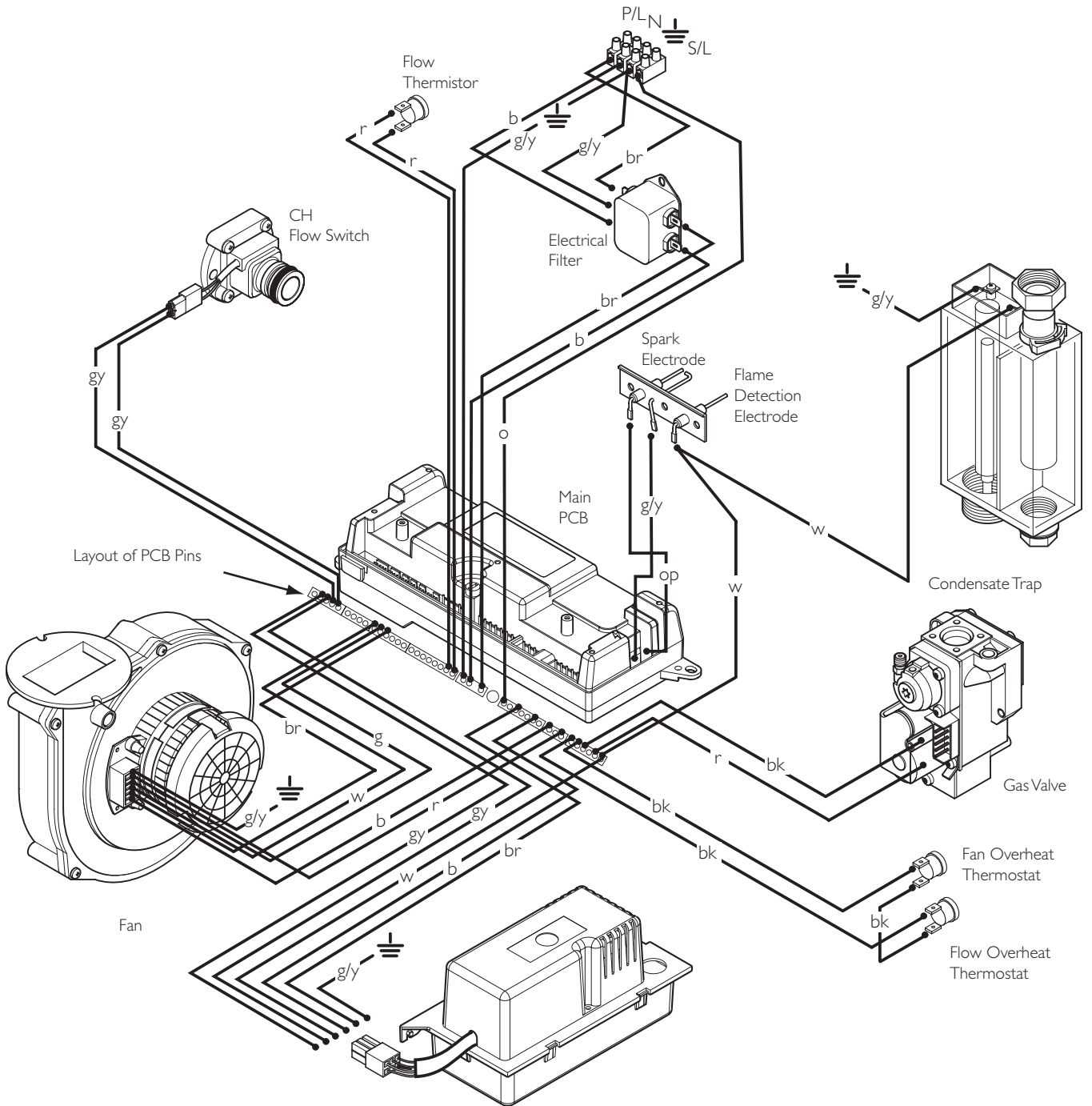

Wiring Key

- b - Blue
- bk - Black
- br - Brown
- r - Red
- w - White
- g/y - Green/Yellow
- g - Green
- gy - Grey
- op - Opaque
- y - Yellow

10.0 Commissioning the Boiler

10.1 Commissioning the Boiler

For correct operation of the flow switch the boiler and system **MUST** be completely vented. The boiler flow pipe incorporates a manual air vent.

1. Reference should be made to BS 5449 Section 5 when commissioning the boiler.

2. Flush the whole system using a suitable flushing agent (see Section 6.2). Vent the radiators and boiler, and any other vents on the system. Check for water leaks.

3. Refill the system with inhibitor following the inhibitor manufacturer's instructions and BS 7593 Code of Practice for Treatment of Water in Domestic Hot Water Central Heating Systems (see Section 6.2).

4. Complete the label supplied with the inhibitor and attach to the inside of the boiler case. Detail of system treatment should be added for future reference.

Failure to flush and add inhibitor to the system will invalidate the boiler warranty.

5. Turn the gas supply on and purge according to, in GB BS 6891, and in IE I.S. 813 "Domestic Gas Installations".

6. Turn the gas service cock anticlockwise to the ON position and check for gas tightness up to the gas valve (Fig. 34). Turn the power to the boiler ON.

WARNING: The PCB Control and Fan Assembly are 325 Vdc.

7. Turn the boiler control knob fully clockwise to 'HIGH' (Fig. 35) and run the system and check the boiler for correct operation. Vent the system.

8. With the system cold and all controls calling for heat check the gas pressure at the inlet tapping of the gas valve (Fig. 36). The pressure must be a minimum of 18.1 mbar (Working Pressure).

**NOTE: The boiler is self-regulating dependent upon the system load. It will modulate between inputs of 33.76kW and 10.3kW.
No adjustment of the gas valve is permissible.**

10.2 Priming the Condensate Pump

1. Using a funnel and tube, carefully pour approximately 1 litre of tap water into the flue products exhaust at the terminal or flue elbow sampling point to fill the trap and allow the condensate pump reservoir to fill.

2. Continue filling with water until the condensate pump operates, as indicated by the boiler facia LED.

3. Check that the condensate drain pipework is not leaking and that it is discharging correctly to drain.

4. See Fig. 36a for operation of LEDs on boiler facia.

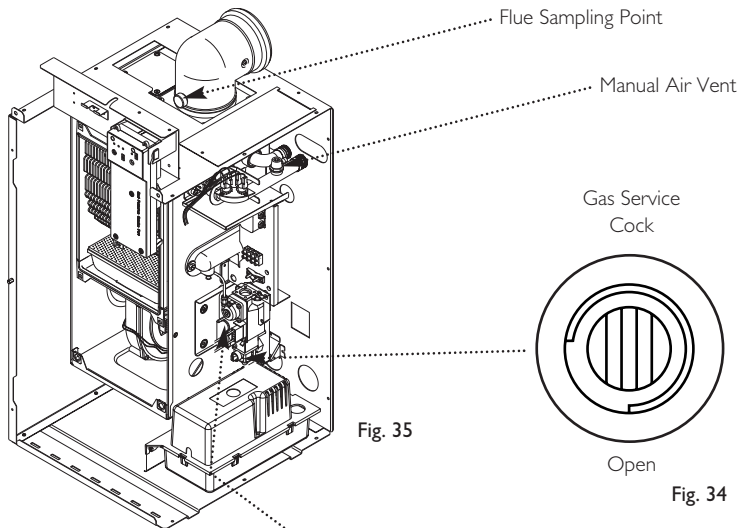

DO NOT check gas pressure here

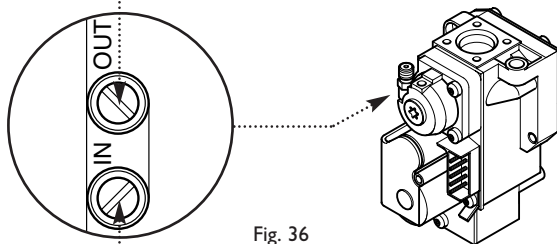

Inlet Gas Pressure Test Point







 <p>Low High</p>	<p>Central Heating Control Knob (No OFF Position)</p>	<p>Turn the Central Heating Control Knob clockwise to increase or anticlockwise to decrease the boiler flow temperature.</p>
 <p>Reset</p>	<p>Reset Button</p>	<p>The Reset Button should extinguish the Flame Failure Light and restore normal operation.</p>
	<p>Mains On (Green Light)</p>	<p>This indicates that there is electricity to the Boiler.</p>
	<p>Burner On (Green Light)</p>	<p>This indicates that the Burner has fired up and is heating your system.</p>
	<p>Flame Failure (Red Light)</p>	<p>If Flame Failure Light is ON. Press the Reset Button. If Flame Failure occurs persistently consult your Installer or Service Engineer.</p>
	<p>Condensate Pump (Green Light)</p>	<p>This indicates that the Condensate Pump is running. The pump ONLY runs when the condensate reservoir is full.</p>

Fig. 36a

11.0 Completion

11.1 Fitting The Case Panels & Facia

1. Refit the case top panel and front door, securing with the screws previously removed (Fig.37).
2. Locate the facia panel and secure with the screws previously removed (Fig. 38).
3. The "Important Ventilation Information" label can be removed unless the boiler is installed in an unventilated compartment.

11.2 'Benchmark' Checklist

1. Carefully read and complete all sections of the Benchmark Commissioning Checklist at the rear of this publication that are relevant to the boiler and installation. **These details will be required in the event of any warranty work.** The publication must be handed to the user for safe keeping and each subsequent regular service visit recorded.
2. For IE, it is necessary to complete a "Declaration of Conformity" to indicate compliance to I.S. 813. An example of this is given in I.S. 813 "Domestic Gas Installations". This is in addition to the Benchmark Commissioning Checklist.

11.3 Handover

1. Instruct the user in the operation of the boiler and system controls. Hand over the User's Operating, Installation and Servicing Instructions, giving advice on the necessity of regular servicing.
2. Demonstrate to the user the action required if a gas leak occurs or is suspected. Show them how to turn off the gas supply at the meter control, and advise them not to operate electric light or power switches, and to ventilate the property.
3. Show the user the location of the system control isolation switch, and demonstrate its operation.
4. Advise the user that they may observe a plume of vapour from the flue terminal, and that it is part of the normal efficient operation of the boiler.

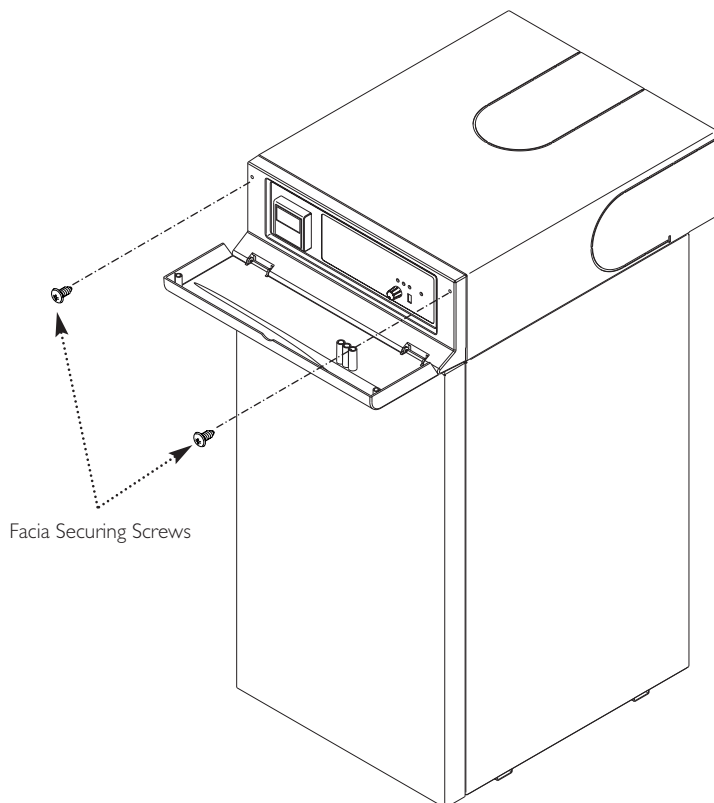
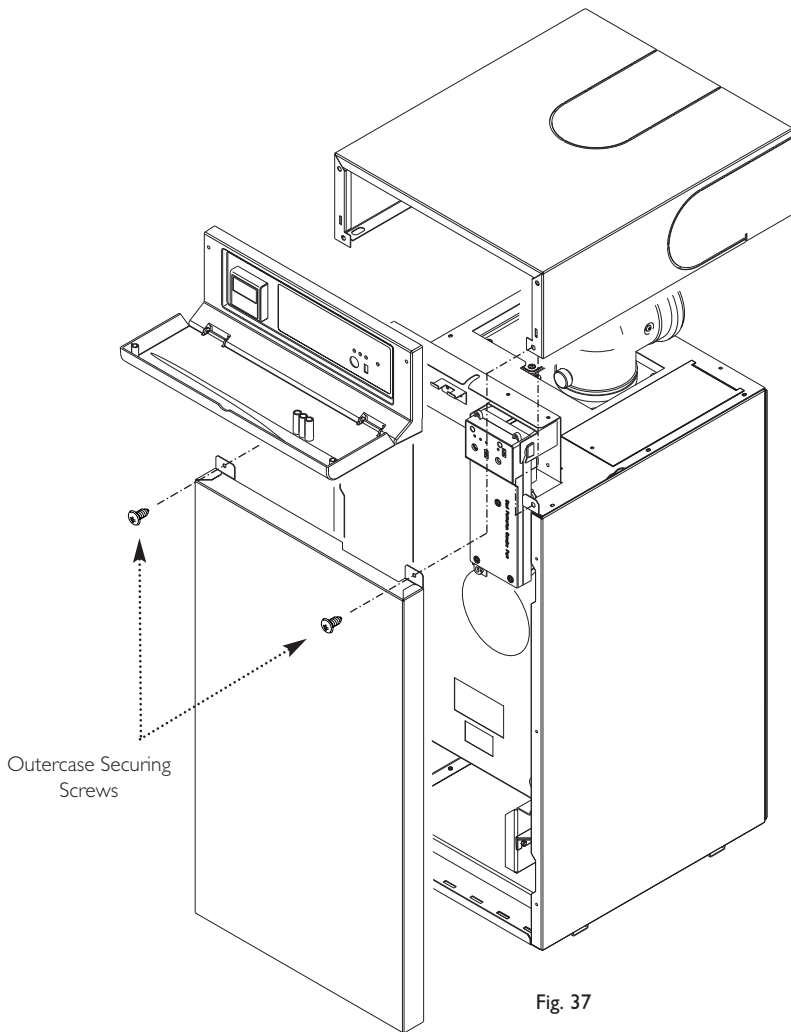

12.0 Servicing the Boiler

12.1 Annual Servicing

1. For reasons of safety and economy, it is recommended that the boiler is serviced annually.

WARNING: The PCB Control and Fan Assembly are 325 Vdc. Isolate system controls before access.

IMPORTANT: When servicing ensure that both the gas and electrical supplies, including Switched and Permanent Live to the boiler are isolated before any work is started. The four LEDs on the fascia will all be OFF.

It is important to isolate the electrical supply at the system isolation switch as it is not possible to do this on the boiler itself.

Hazardous materials are not used in the construction of this product, however reasonable care during service is recommended - see Section 1.2.

When replacing the combustion box door after servicing it is essential that the retaining screws are tightened fully.

After servicing, complete the relevant Service Interval Record section of the Benchmark Commissioning Checklist at the rear of this publication.

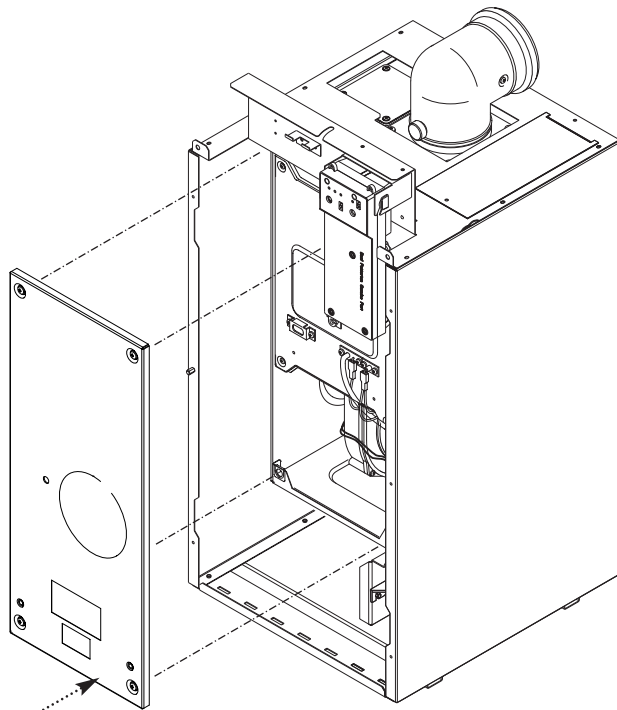

Air Box Door Panel

Fig. 39

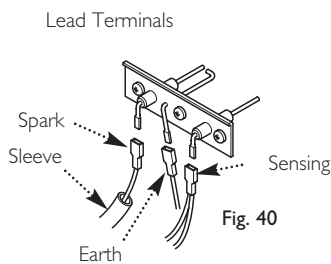
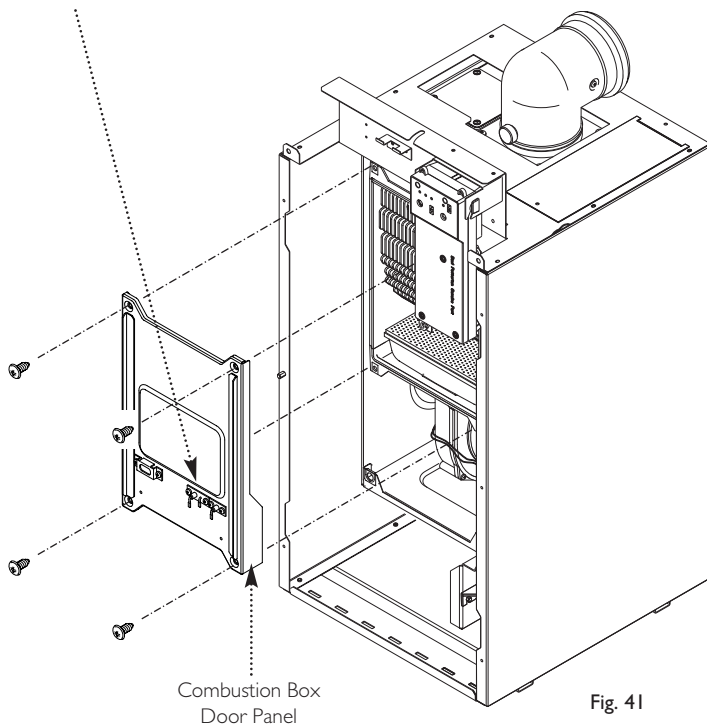

Fig. 40



Combustion Box Door Panel

Fig. 41

2. Ensure that the boiler is cool.
3. Remove the fascia and front door panel.
4. Release the four 1/4 turn screws securing the air box door panel and remove the panel (Fig. 39).
5. Disconnect the three leads from the terminals (Fig. 40).
6. Undo the four screws securing the combustion box door and remove the door (Fig. 41).
7. Visually check for debris/damage and clean or replace if necessary the following:
 - a) Burner.
 - b) Heat exchanger fins.
 - c) Fan compartment (Check also for condensate leaks).
 - d) Insulation.
 - e) Door seals-**Important:** Pay particular attention to the condition of the combustion box door seals.
 - f) Electrodes.
 - g) The condensate trap.
 - h) The condensate pump
 - i) Top of heat exchanger.

12.0 Servicing the Boiler

12.1 Annual Servicing (Cont)

9. To clean the heat exchanger and burner proceed as follows:

- a) Disconnect the electrical leads to the fan component protection sensor (Fig. 42).
- b) Loosen the screw retaining the gas injector pipe at the venturi (Fig. 42).
- c) Undo the two wing nuts to disconnect the fan (Fig. 42).
- d) Remove the fan and disconnect the electrical supply to it (Fig. 42).

- e) Remove the gas injector pipe from the gas valve (push-fit) (Fig. 42).
- f) Remove the condensate trap drain plug and place a vessel underneath to catch the condensate (care should be taken as this could be hot). The condensate drain pipe may be removed to increase access.

- g) Undo the condensate trap securing nut, lock nut and the condensate drain pipe. Remove the condensate trap and disconnect the sensor leads (Fig. 43). Clean the trap and refit the drain plug.

- h) Remove the two screws securing the burner and remove the burner. Visually inspect the internal burner baffle for obstruction, check seal around baffle for cracks/damage. Clean with a soft brush.

- i) Loosen the two screws retaining the heat exchanger support bracket and slide to the left to remove (Fig. 44).

- j) Remove the four screws securing the heat exchanger/combustion box base and withdraw the base.

- k) Lower the central insulation panel and check condition (Fig. 44). Replace the lower insulation pad if necessary.

- l) Ensure the heat exchanger fins are clear of any obstruction.

- m) Check condition of all seals. **Important: Pay particular attention to the condition of the combustion box door seals.**

- n) Reassemble in reverse order and check for leaks.

10. Check the operation of the condensate pump and drain pipework (see Section 10.1)

11. Check CO/CO₂ ratio at flue sampling point (Fig.41a). See section 4.0.

12. Complete the relevant Service Interval Record section of the Benchmark Commissioning Checklist at the rear of this publication and then hand it back to the user.

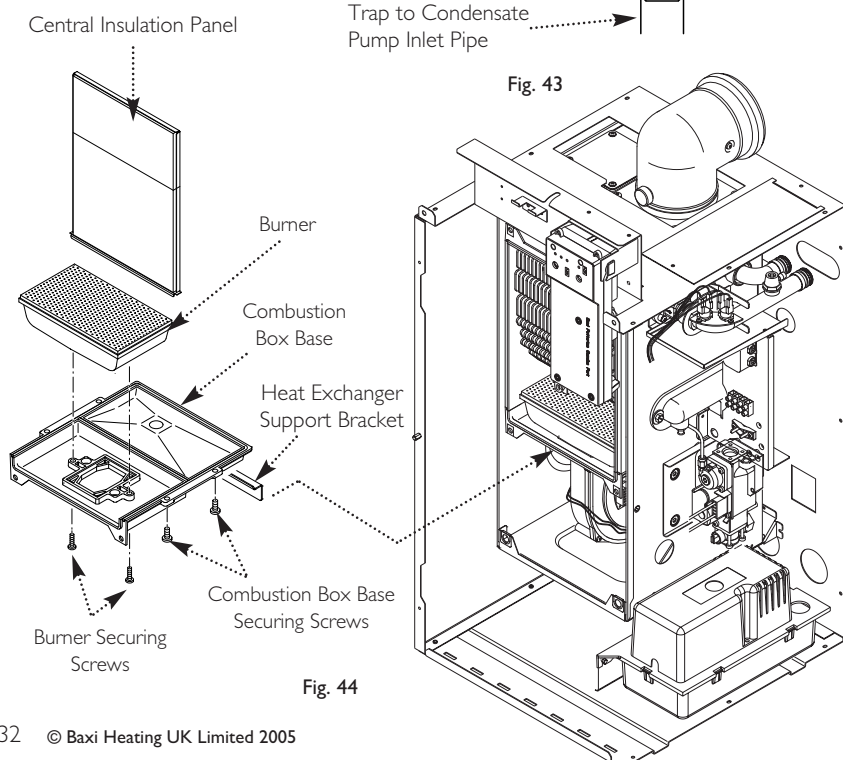
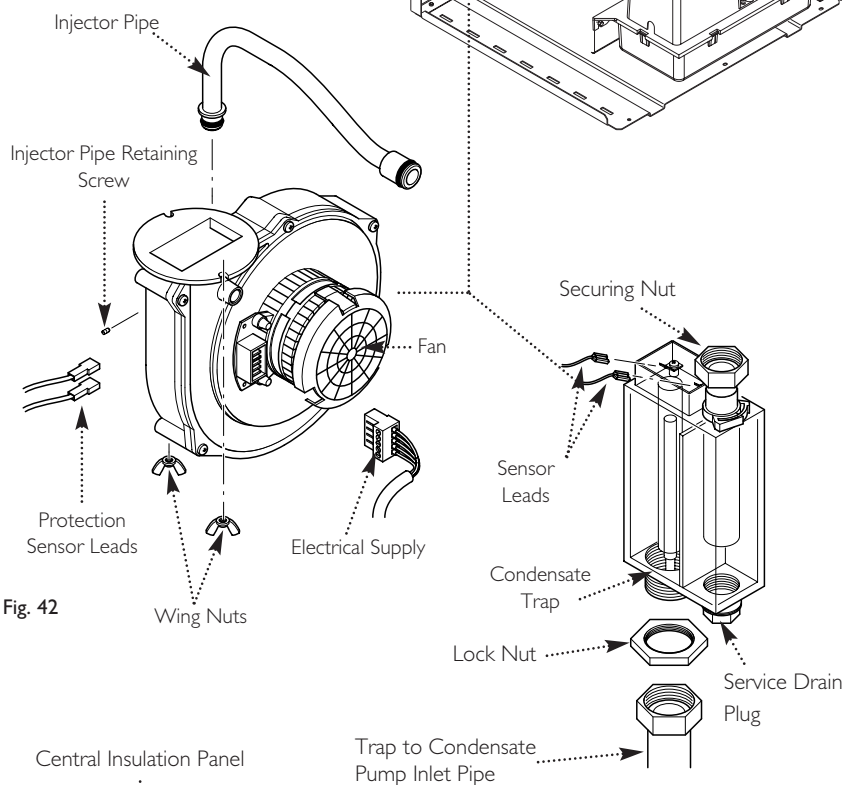
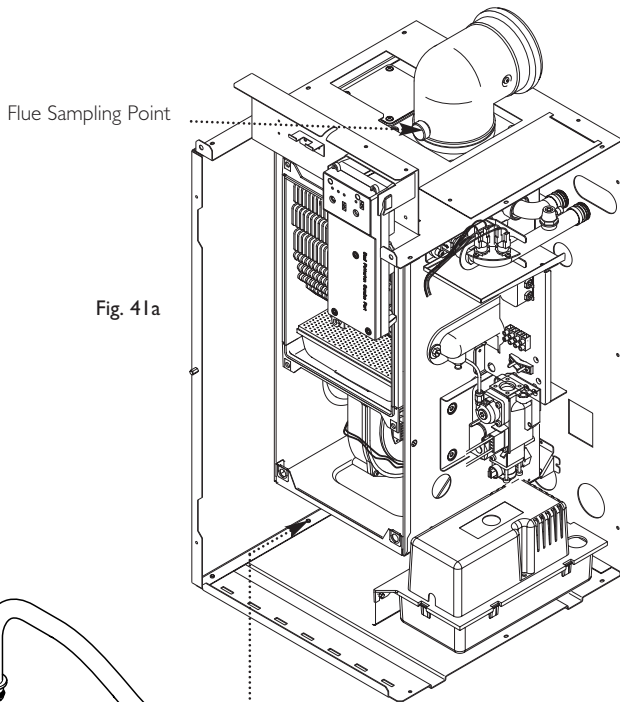

13.0 Changing Components

13.1 Changing Components & Preparation

WARNING: The PCB Control and Fan Assembly are 325 Vdc. Isolate system controls before access.

IMPORTANT: Ensure that both the gas and electrical supplies, including Switched and Permanent Live to the boiler are isolated before any work is started. The four facia LEDs will be all OFF.

It is important to isolate the electrical supply at the system isolation switch as it is not possible to do this on the boiler itself.

Hazardous materials are not used in the construction of this product, however reasonable care is recommended - see Section 1.2.

When replacing the combustion box door it is essential that the retaining screws are tightened fully.

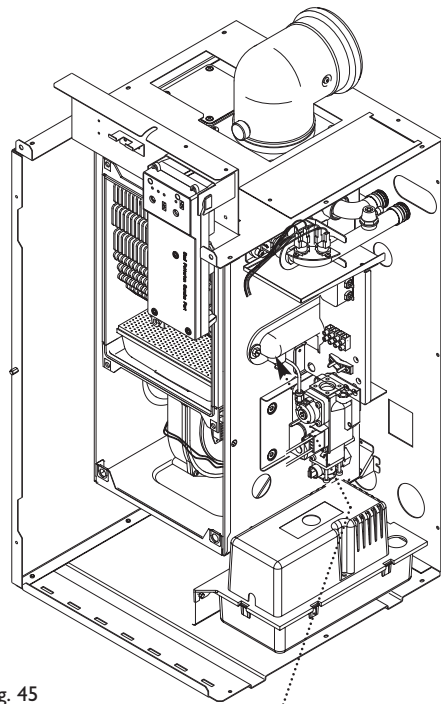
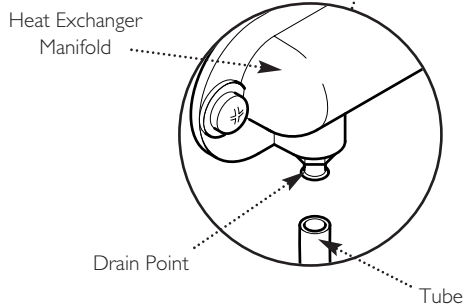

Fig. 45



Remove the facia and front door panel.

For the replacement of some components it will be necessary to drain the boiler. Proceed as follows:-

1. Isolate the water circuit and drain the system as necessary. A drain point is located on the heat exchanger manifold at the right hand side of the boiler (Fig. 45) to enable the heat exchanger to be drained.
2. Place a tube on the drain point to drain water away from the electrics. Turn anticlockwise to open (Fig. 45).
3. After changing a component recommission the boiler where appropriate and check the inhibitor concentration (see Section 6.2 and 10.1).

The thermistor, safety thermostat, interface PCB and the flow switch can be accessed after removal of the pipe access panel (Fig. 46).

13.2 Flow Temperature Thermistor and Safety Thermostat (Fig. 46)

1. The procedure is the same for both the thermistor and the safety thermostat.
2. Remove the pipe access panel and disconnect the electrical connections from the sensor.
3. Remove the sensor from the pipe.
4. Fit the new thermistor or safety thermostat and reassemble in reverse order.

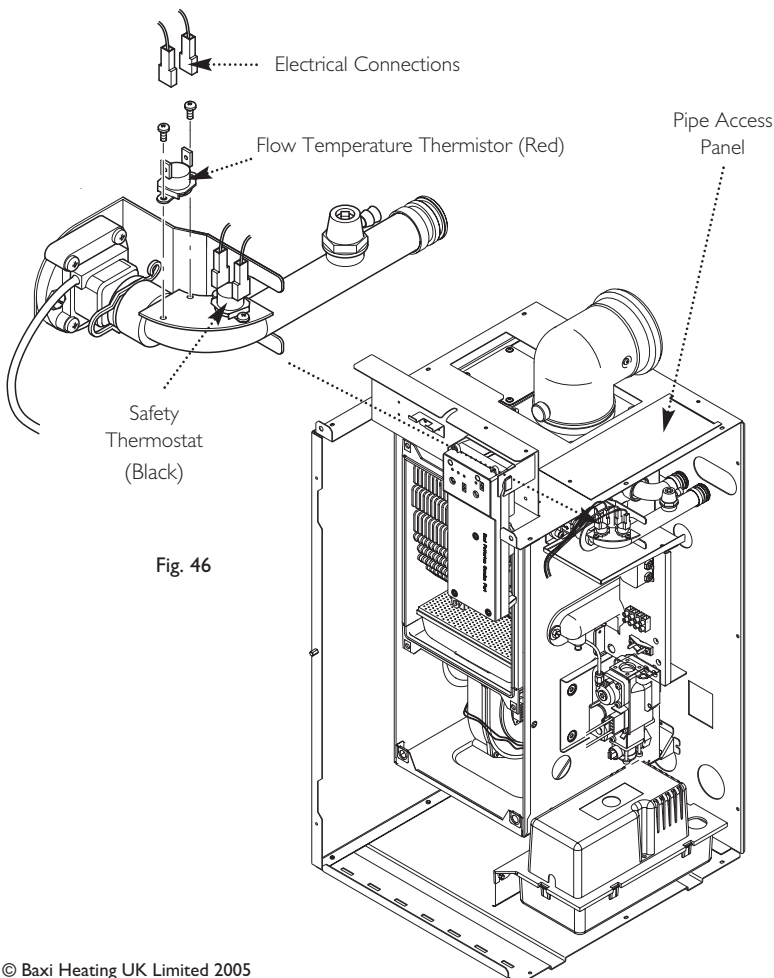

Fig. 46

13.0 Changing Components

13.3 Flowswitch (Fig. 47)

1. Drain the boiler (see Section 13.1 paragraph 2 & 3).
2. Remove the pipe access panel and remove the securing clip from the 'O' ring joint between the flow pipe and the system. Undo screws on support bracket.
3. Remove the securing clip from the 'O' ring joint between the flow pipe and the flowswitch.
4. Remove the two screws securing the flow switch to the boiler.
5. Disconnect the inline electrical connection and remove the flowswitch.
6. Fit the new flowswitch and reassemble in reverse order.
7. Recommission the boiler and check the inhibitor concentration (see Section 6.2 and 10.1).

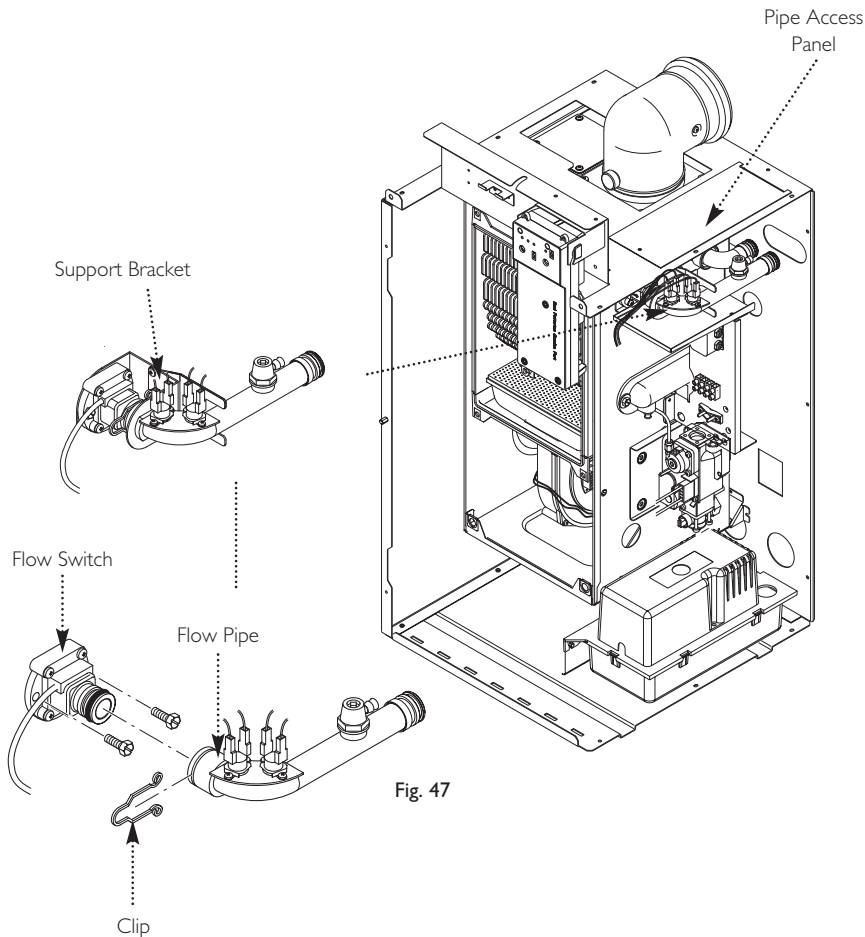

Fig. 47

Over Level Switch

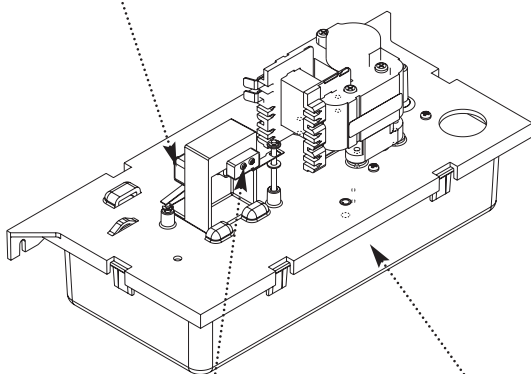
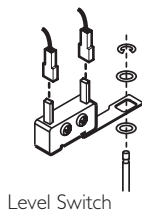

Fig. 47a

Condensate Pump
(Cover Removed)



Level Switch

13.4 Condensate Pump - Complete (Fig. 47a)

1. Remove the pipe from the trap to the pump inlet and disconnect the electrical plug.
2. Lift the pump off the support studs and ease it forwards. Release the snap fit clip and disconnect the condensate outlet pipe.
3. Connect the condensate outlet pipe to the new pump using the new clip provided.
4. With the new pump in place on the studs, refit the trap discharge pipe, ensuring the 'O' ring is in place. Reconnect the electrical plug.
5. Neatly coil the excess condensate outlet pipe adjacent to the pump, ensuring that it is not kinked or restricted.
6. Check operation of the pump - See Section 10.2.

13.5 Condensate Pump - Level Switches (Fig. 47a)

1. Remove the complete Condensate Pump as described in Section 13.4, and remove the cover.
2. Disconnect the wires from the switch(es) and remove the retaining screws. On the Level Switch remove the circlip and washers connecting the plunger to the actuating arm.
3. Fit the new switch(es). Align the actuating arm of the Level Switch with the plunger, ensuring that there is a washer at each side of the arm.
4. Reconnect the wires. On the Over Level Switch there is no connection to the lower spade terminal.
5. Check operation of the pump - See Section 10.2.

13.0 Changing Components

13.6 PCB (Figs. 48 & 49)

WARNING: The PCB Control and Fan Assembly are 325 Vdc. Isolate system controls before access.

1. Pull the control knob off the spindle and remove the plastic button cover. Refit them onto the new PCB (Fig. 48).
2. Remove the top right hand securing screw and swing out the PCB housing. Remove the PCB cover and disconnect the electrical plugs noting their positions
3. Remove the screw securing the PCB to the housing. The PCB can be removed from the housing.
4. Ensure that the two jumpers are fitted to the new PCB as shown (Fig. 49).
5. Reconnect the plugs, fit the new PCB to the housing and reassemble in reverse order.

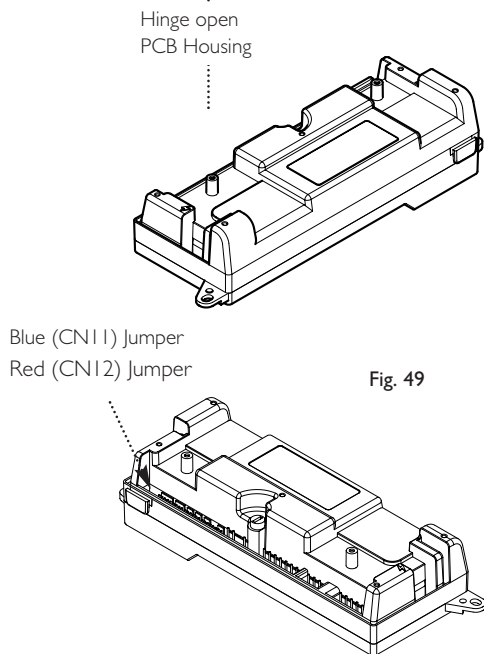
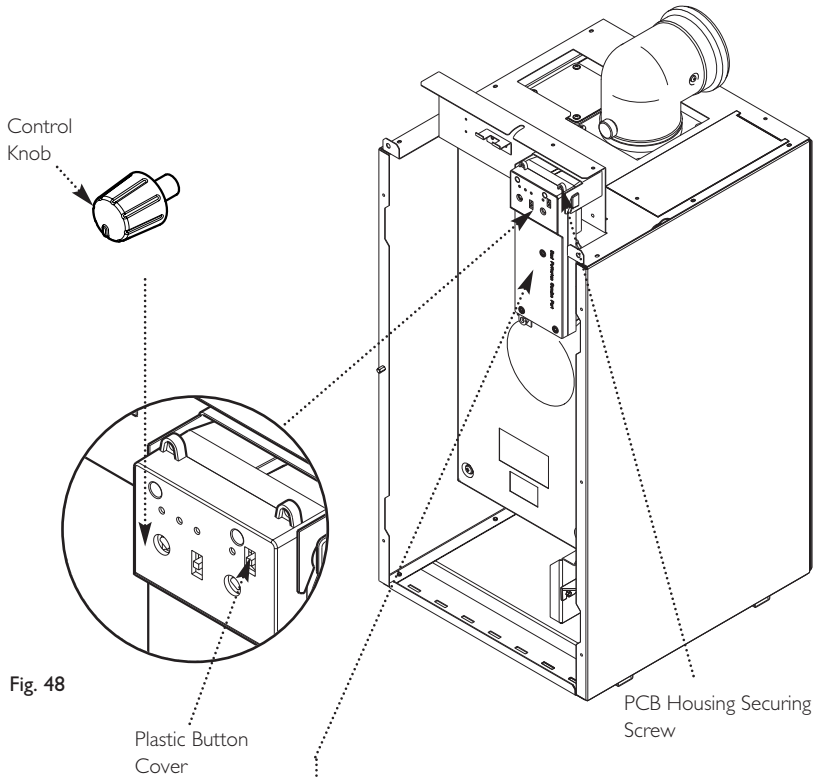

13.0 Changing Components

The fan and venturi, gas valve, injector pipe, condensate trap, fan protection sensor, spark and sensing electrodes can be accessed and changed on the removal of the airbox door panel.

1. Remove the airbox door panel by loosening the four $\frac{1}{4}$ turn screws (Fig. 50).

13.7 Spark and Sensing Electrodes (Fig. 51)

1. Disconnect all three leads from tabs.

Spark	-	Opaque cable
Earth	-	Green/Yellow cable
Sensing	-	White cable
2. Remove the two screws securing each of the electrodes to the combustion box door and remove the electrodes.
3. Fit the new electrodes (and new gasket, as required) and reassemble in reverse order.

13.8 Fan (Fig. 52)

WARNING: The PCB Control and Fan Assembly are 325 Vdc. Isolate system controls before access.

1. Loosen the screw holding the injector pipe into the venturi.
2. Remove the electrical connections to the fan and protection sensor on the fan.
3. Remove the wing nuts securing the fan to the base of the combustion box.
4. Lower the fan and remove.
5. If changing the fan, remove the screws securing the venturi and fan protection sensor bracket, noting the positions of the injector opening and sensor bracket, fix them to the new fan.
6. Fit the new fan and reassemble in reverse order.

The injector pipe, condensate trap and gas valve can be changed after the removal of the fan.

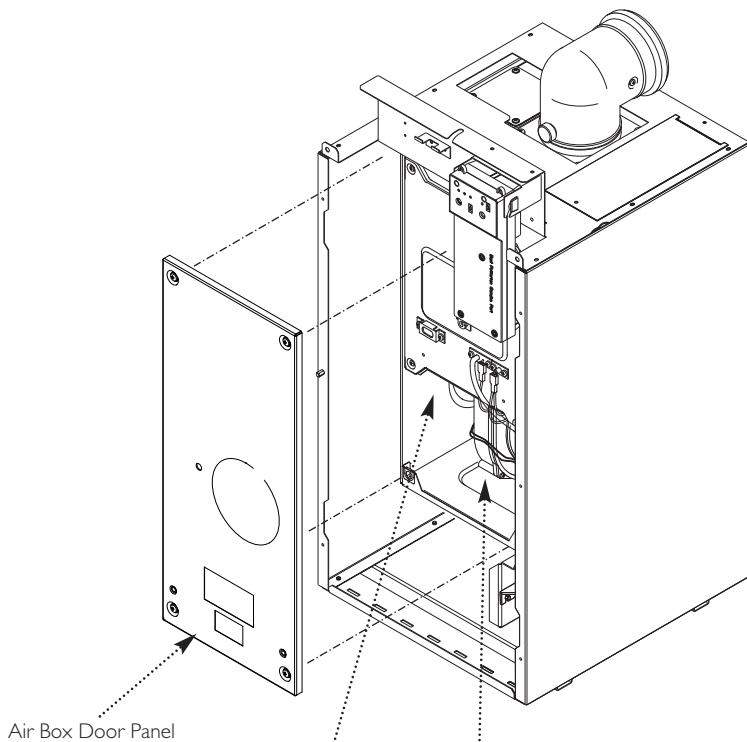

Fig. 50

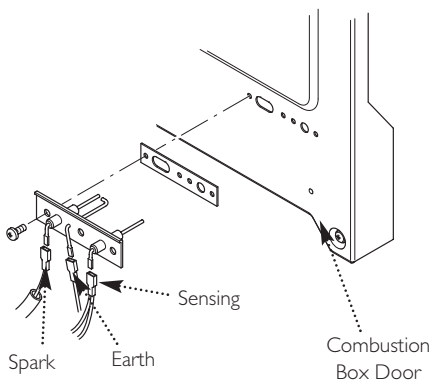

Fig. 51

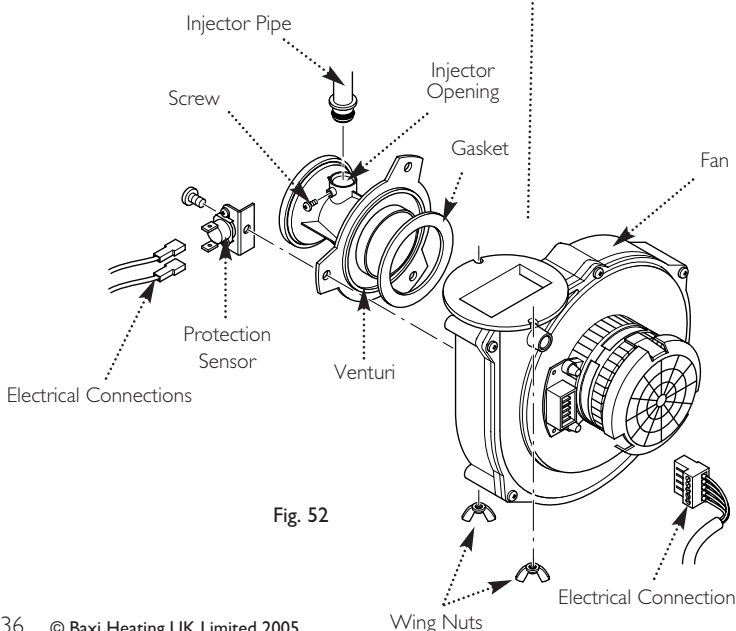

Fig. 52

13.0 Changing Components

The removal of the fan is necessary to enable the changing of the injector pipe, condensate trap and gas valve (see section 13.6).

13.9 Injector Pipe (Fig. 53)

1. Remove the injector pipe by pulling out from the 'O' ring joint in the gas valve.
2. Fit the new injector pipe and reassemble in reverse order.

13.10 Gas Valve (Fig. 53)

1. Isolate gas supply and disconnect the gas tap by removing the four screws.
2. If required remove the condensate pump to increase access (see Section 13.4) and undo the case pressure pipe from the valve.
3. Disconnect the electrical plug from the gas valve.
4. Remove the fan (see Section 13.6) and injector pipe.
5. Remove the two gas valve securing screws from inside the air box holding the gas valve, and remove the valve.
6. Remove the aluminium spacer and its gasket from the gas valve.
7. Fit the aluminium spacer and its gasket to the new valve.
8. Fit the new gas valve and reassemble in reverse order.

NOTE: Check for gas tightness after replacing gas valve.

13.11 Condensate Trap (Fig. 54)

1. Disconnect the condensate trap from the base of the heat exchanger.
2. Disconnect the condensate drain 'O' ring connection from the condensate trap and condensate pump. For ease of access also remove the pump.
3. Undo the condensate trap lock nut.
4. Remove the condensate trap from the boiler.
5. Disconnect the sensor leads.
6. Fit the new condensate trap and reassemble in reverse order. When refitting the pipe from the trap to the pump ensure that all seals and connections are made.
7. Prime the condensate trap (fill first chamber), check for leaks (see Section 8.5).

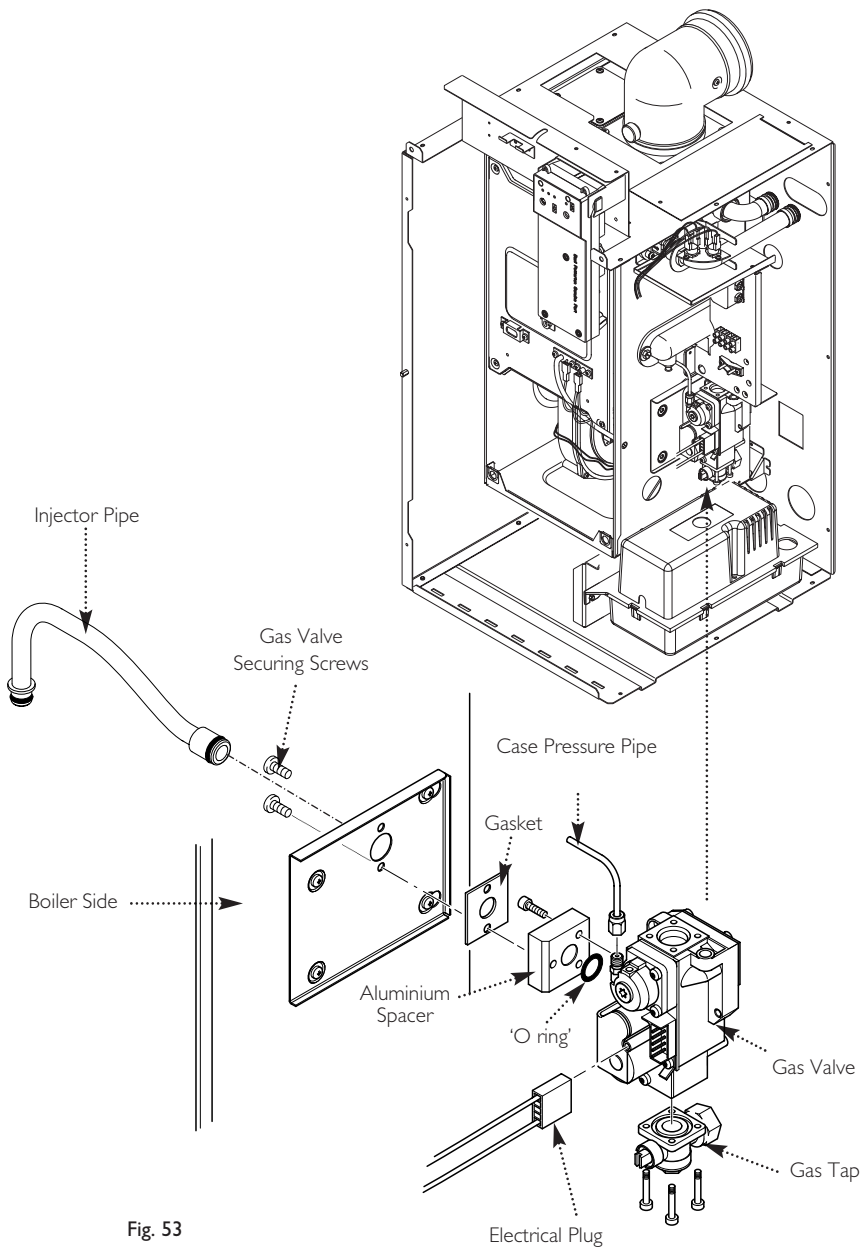

Fig. 53

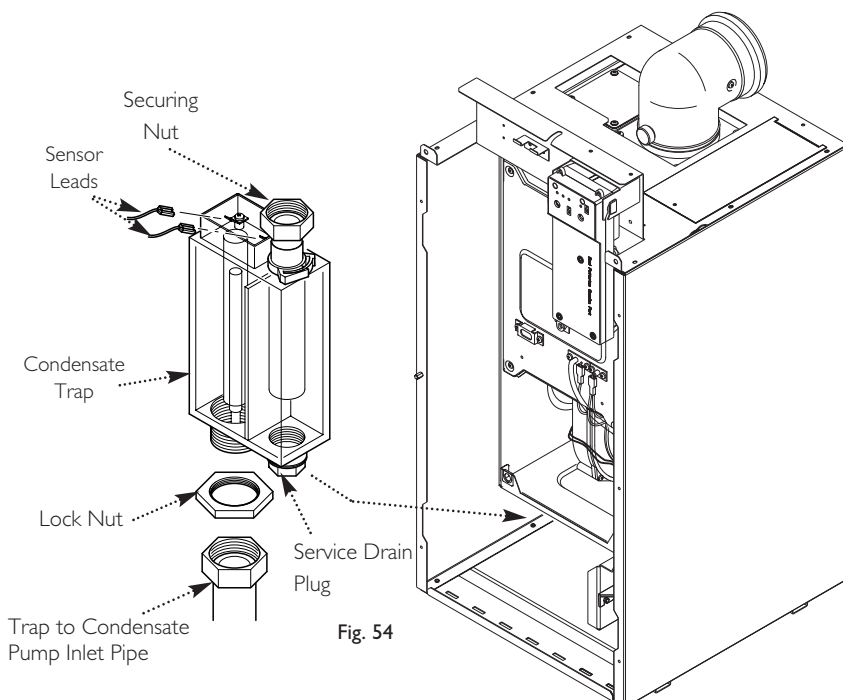

Fig. 54

13.0 Changing Components

The burner and heat exchanger can be changed after removal of the combustion box door. To change the heat exchanger, the fan and burner must be removed first (see section 13.6 and 13.10).

1. Remove the combustion box door by removing the four securing screws (Fig. 55).

IMPORTANT: On refitting the combustion box door check the condition of the combustion box door seals.

13.12 Burner (Fig. 56)

1. Remove the two screws securing the burner to the base of the combustion box.

2. Remove the burner carefully from the combustion box base.

3. Check the burner seal on the heat exchanger base, replace if necessary. Fit the new burner and reassemble in reverse order.

13.13 Heat Exchanger

1. Drain the boiler (see section 13.1 paragraph 2 & 3).

2. Remove all components in the base of the airbox.

3. Undo the screws on the support bracket. Remove the screws securing the flow switch and return connections and remove the connections (Fig. 57).

4. Remove the screws securing the heat exchanger manifold and remove the manifold (Fig. 58).

5. Ease the combustion box left hand side panel to clear the stud, lift the heat exchanger assembly (Fig. 59) and rotate the bottom upwards whilst pulling it forwards out of the airbox.

6. Ensure that the heat exchanger is disengaged from the flue elbow and clear of the stud in the left hand side of the combustion box.

7. Fit the new heat exchanger and reassemble in reverse order.

8. Recommission the boiler and check the inhibitor concentration (see Section 6.2 and 10.1).

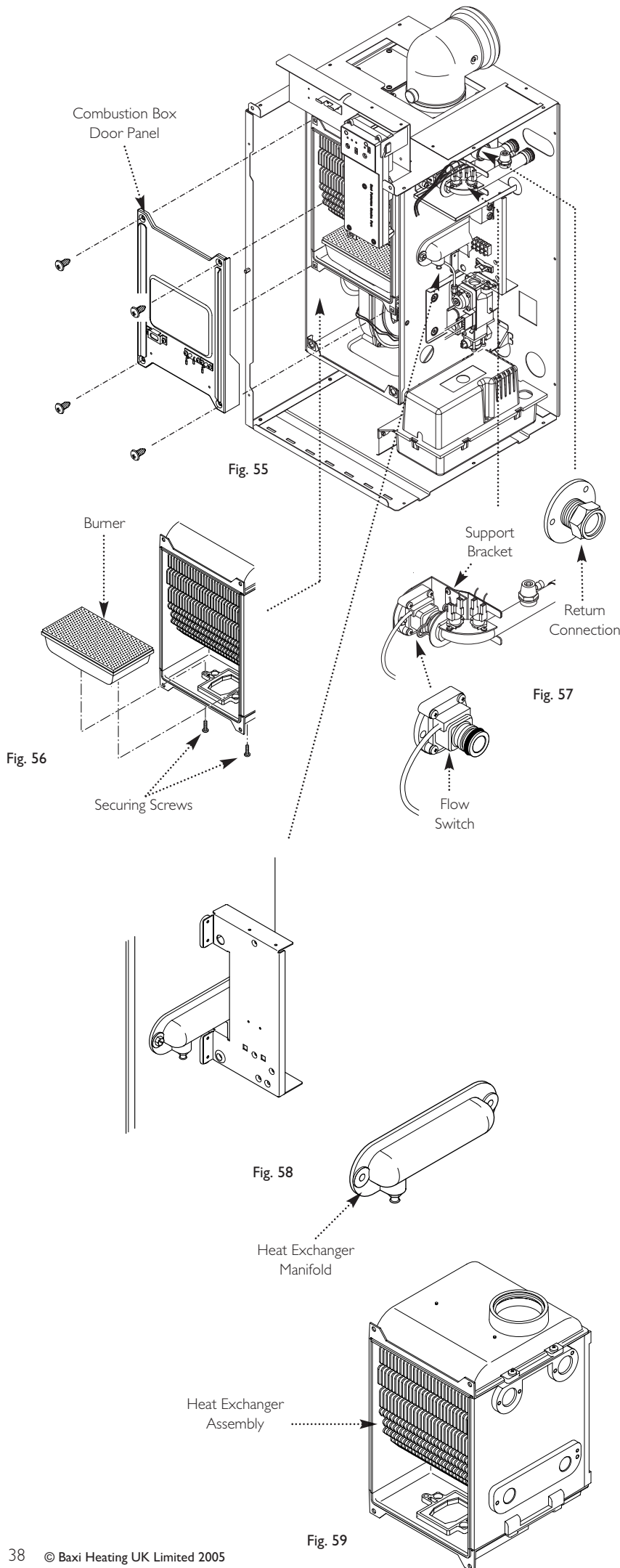

13.0 Changing Components

13.14 Heat Exchanger Lower Insulation Pad (Fig. 60)

1. Remove all components in the base of the airbox.
2. Remove the burner (see section 13.10).
3. Remove the four bolts securing the combustion box base.
4. Remove the combustion box base.
5. Pull the central insulation panel down from the centre of the heat exchanger and remove the lower insulation pad.
6. Fit the new insulation pad and reassemble in reverse order.

13.15 Heat Exchanger Upper Insulation Pad (Fig. 60)

1. Remove all components in the base of the airbox.
2. Remove the burner (see section 13.10).
3. Remove the heat exchanger (see section 13.11).
4. Remove the four bolts securing the combustion box base.
5. Remove the combustion box base.
6. Pull the central insulation panel down from the centre of the heat exchanger.
7. Fit the new insulation pad and reassemble in reverse order.

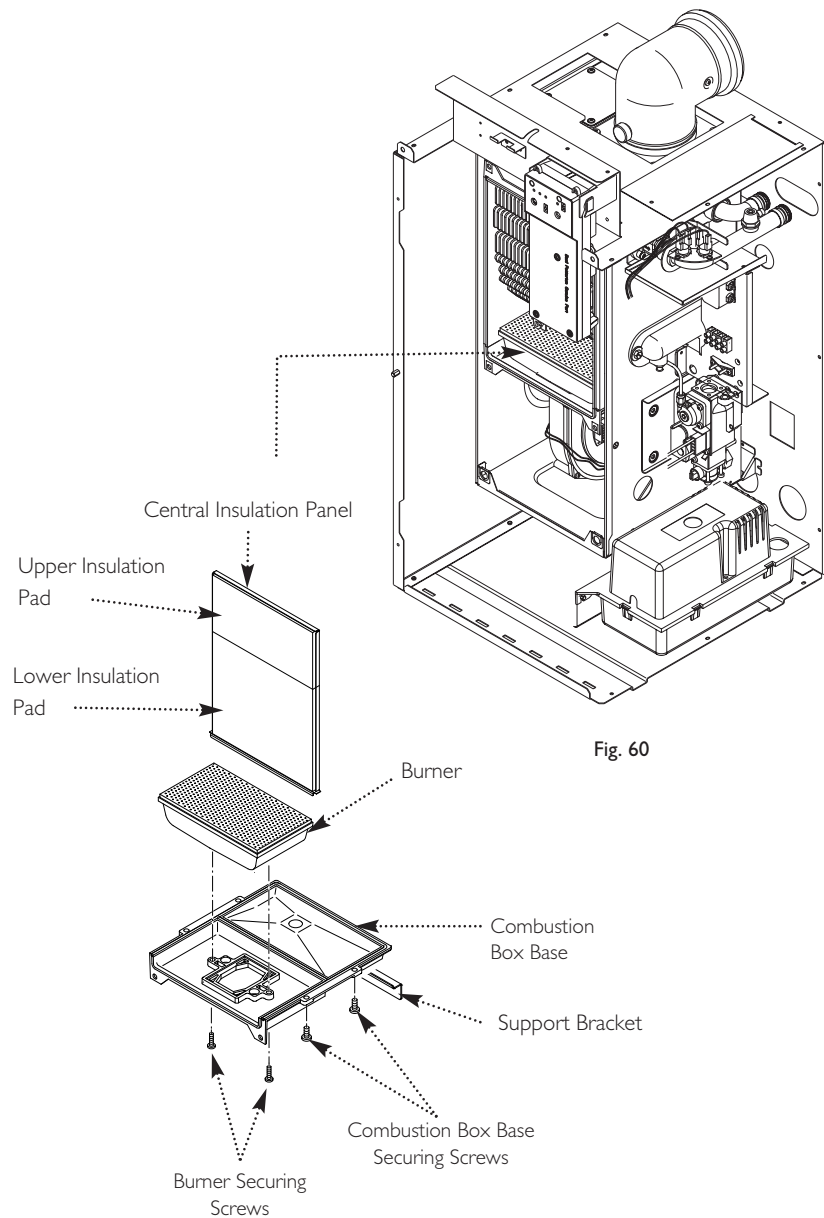
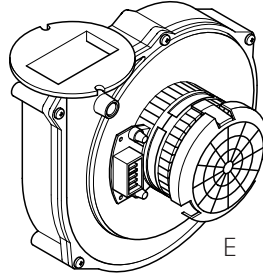
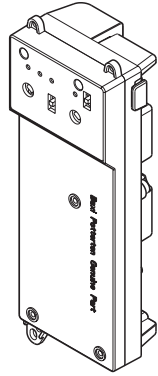
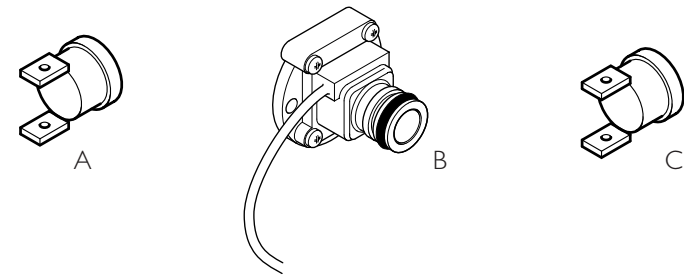

Fig. 60

14.0 Short Parts List

Short Parts List

Key No.	G.C. No.	Description	Manufacturers Part No.
A	E06 058	Flow Temperature Thermistor (Red)	240670
B	E06 059	Flow Switch	242459
C	E06 060	Safety Thermostat (Black)	242235
D		PCB	5117224
E		Fan	5109925
F		Gas Valve	241900
G	E06 085	Viewing Window	242484
H		Condensate Trap	5111714
I		Electrodes Kit	5110992
J		Burner Assy	5107430
K	E06 097	Heat Exchanger Assy	242497
L		Control Knob	5109996
M		Condensate Pump	5117661
N		Level Switch	5117591
O		Over Level Switch	5117592



D

E

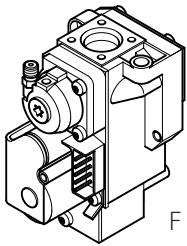

F

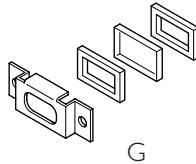

G

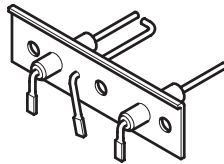

I

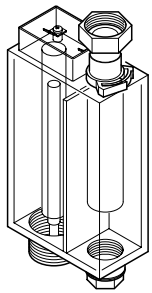

H

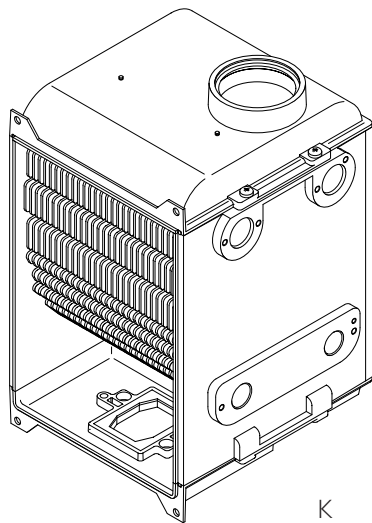

K

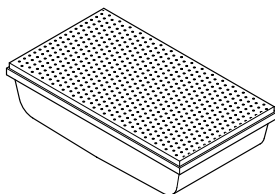

J



L

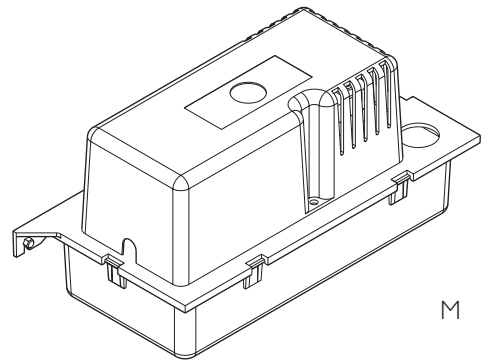

M

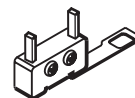

N

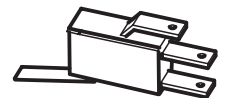

O

15.0 Fault Finding

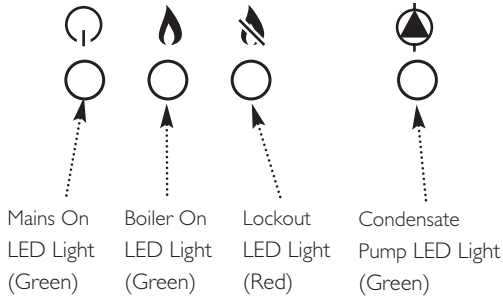

NOTE: The fan is supplied with 325 Vdc.

Fan Fault Finding should only be carried out after the boiler has been electrically isolated.

General Fault Finding should only be carried out by someone who is appropriately qualified.

* denotes LED flashing

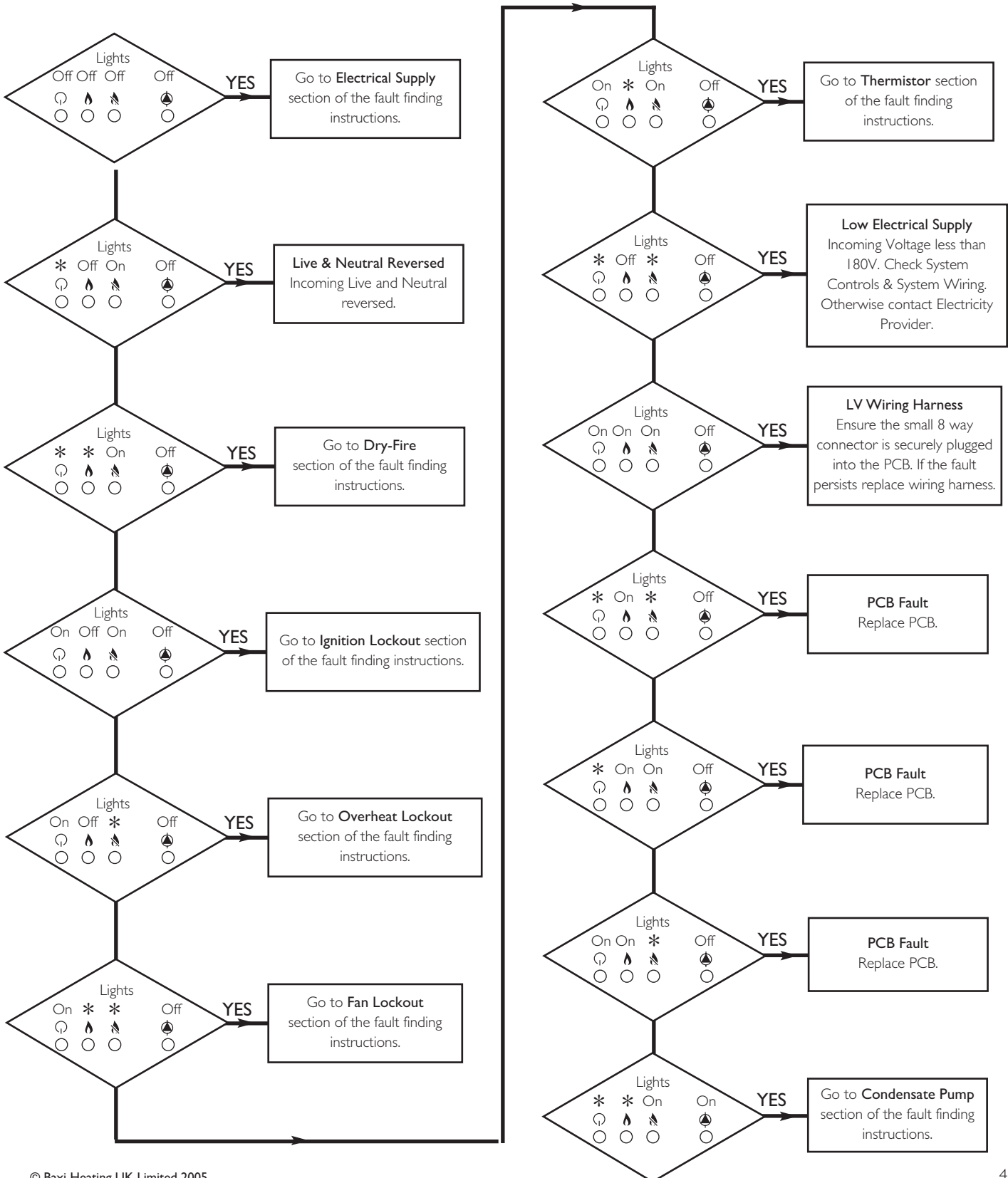

ELECTRICAL SUPPLY

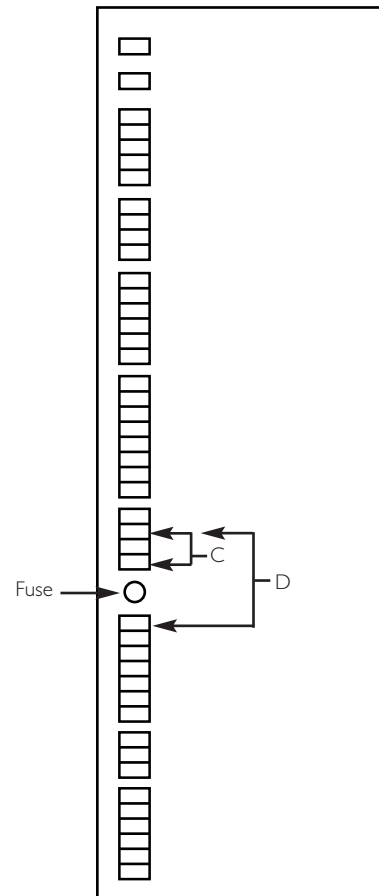
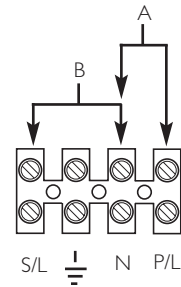
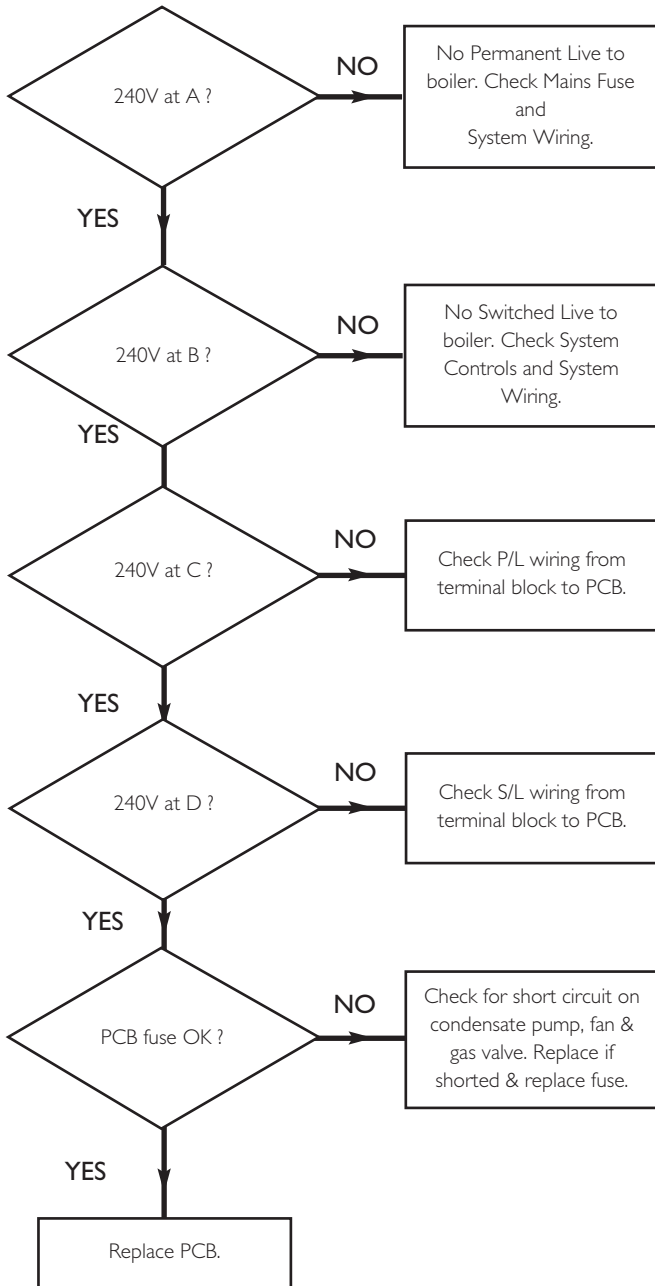
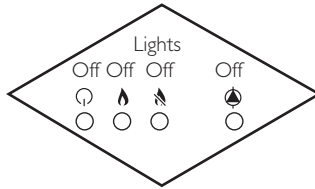

DRY-FIRE

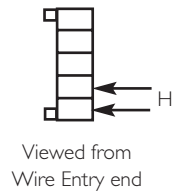
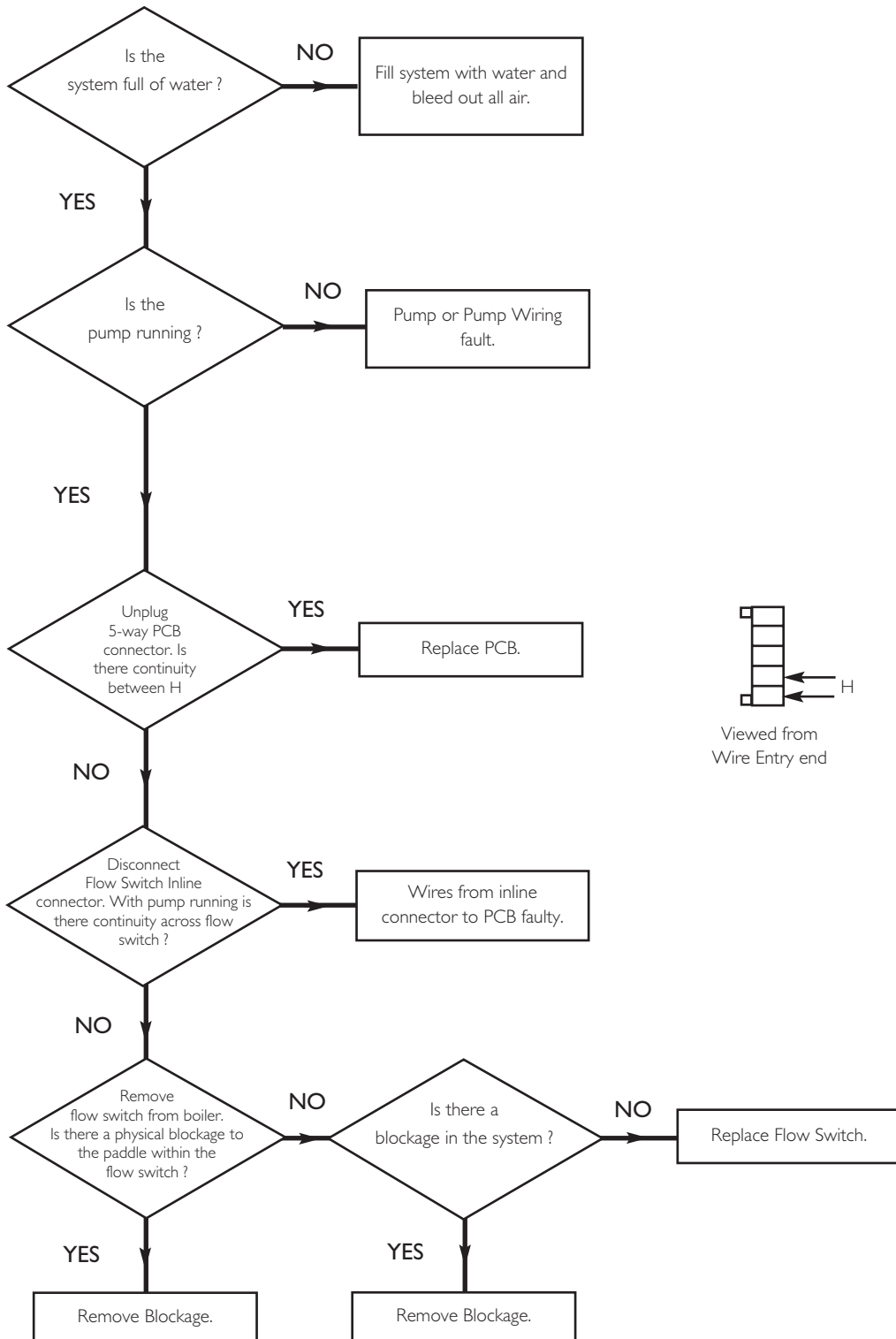
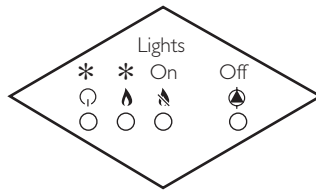

IGNITION LOCKOUT

15.0 Fault Finding

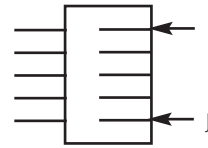
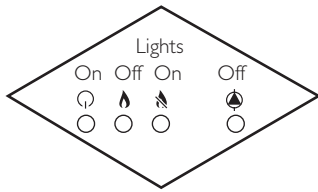

Gas Valve 5-way Connector Plug

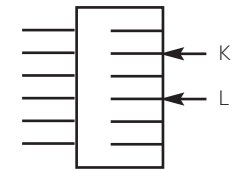

6-way Connector

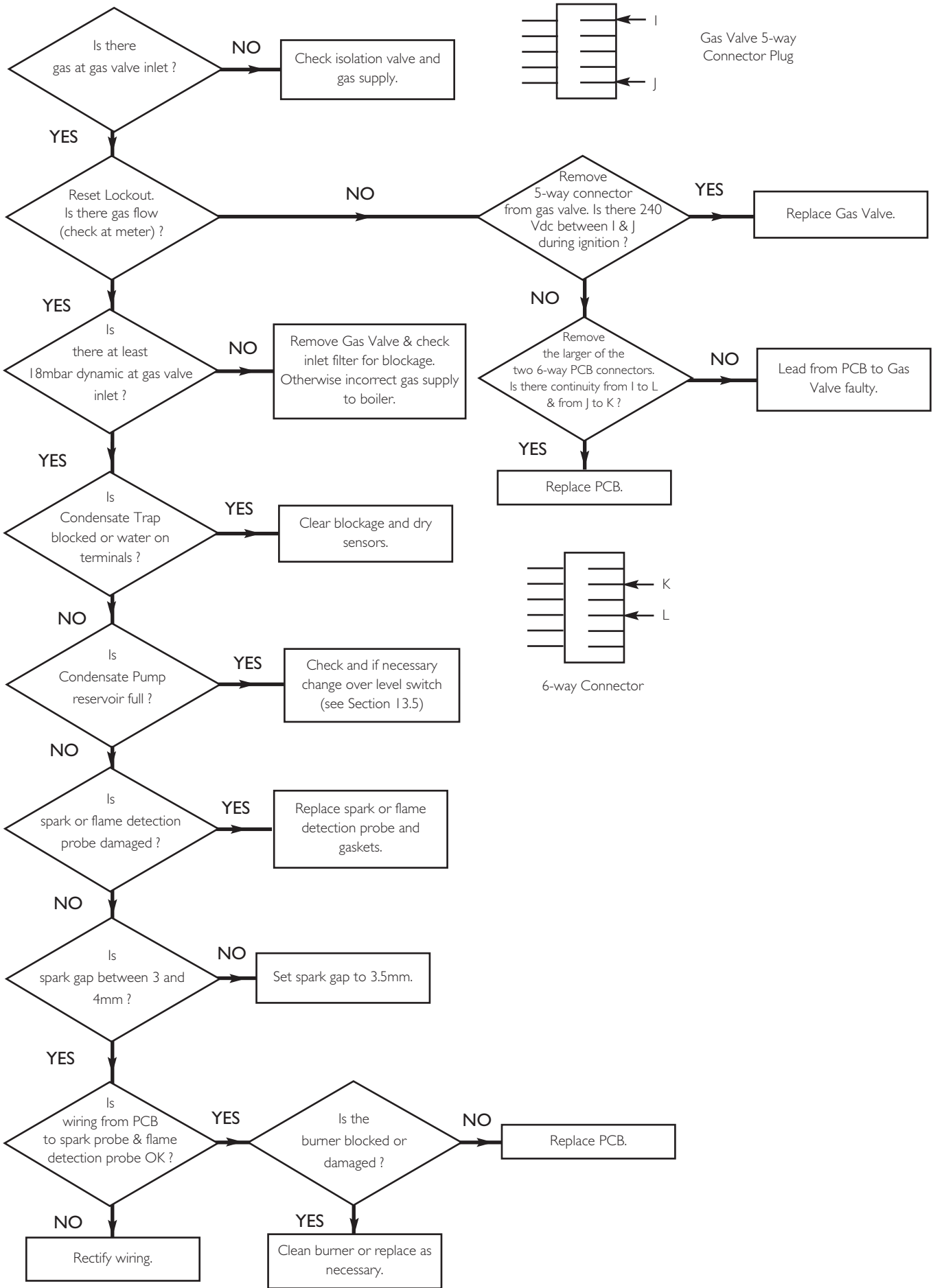

OVERHEAT LOCKOUT

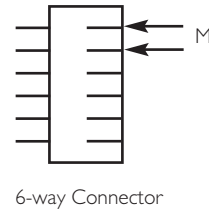
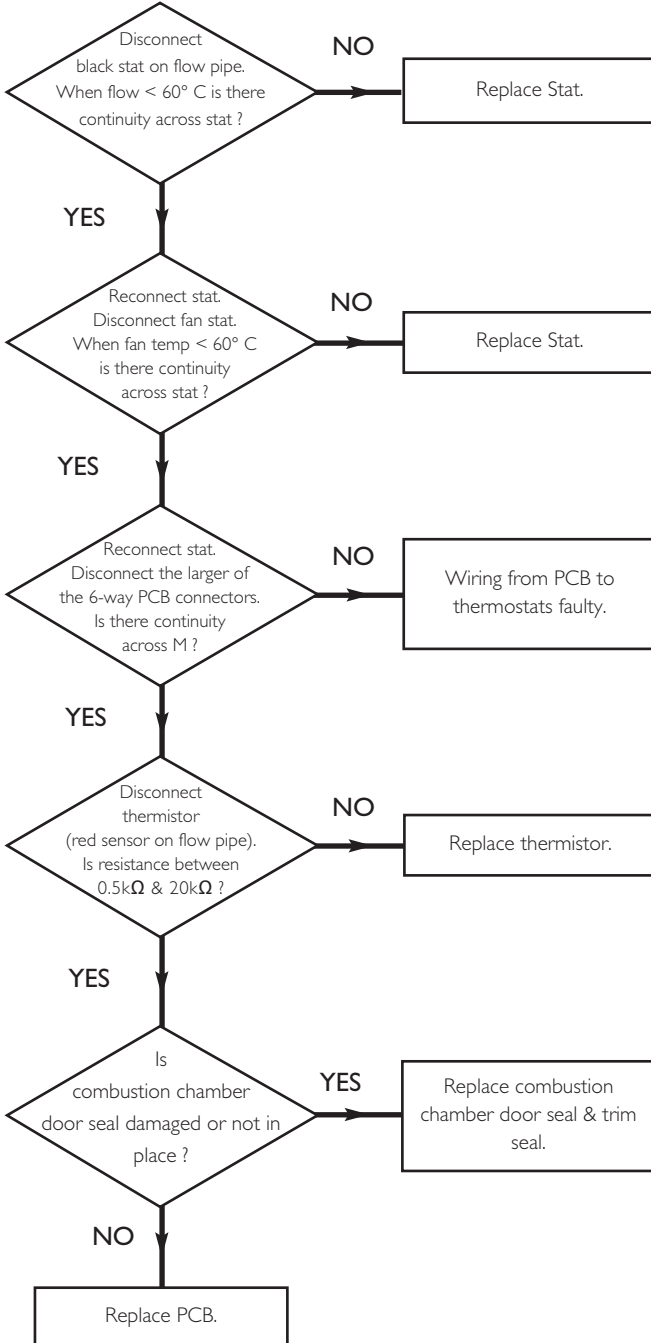
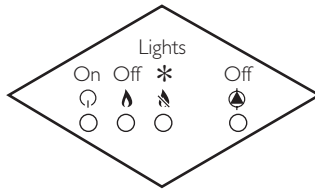

FAN LOCKOUT

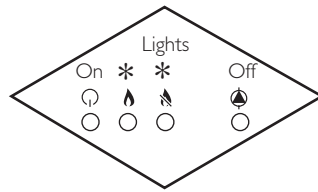

15.0 Fault Finding

NOTE: The fan is supplied with 325 Vdc.

Fan Fault Finding should only be carried out after the boiler has been electrically isolated.

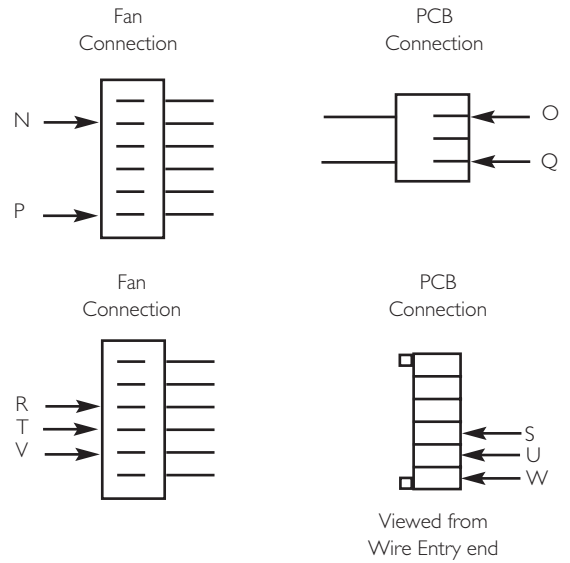
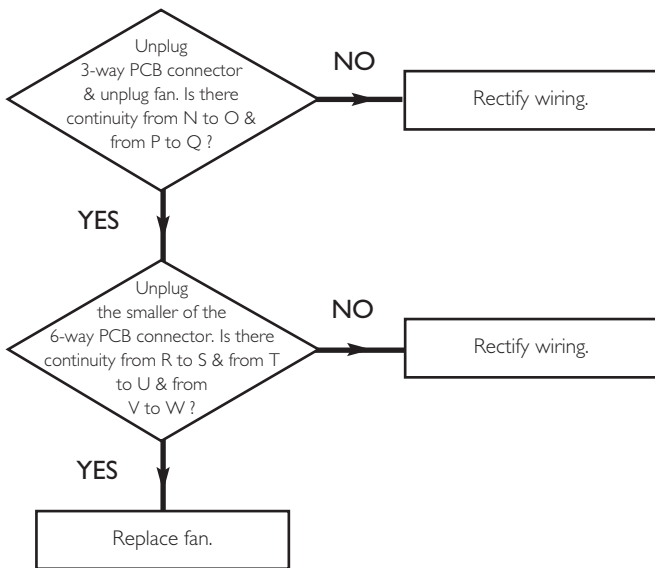

THERMISTOR

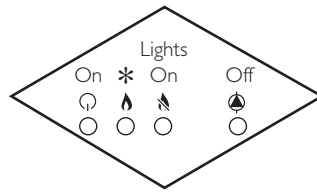

15.0 Fault Finding

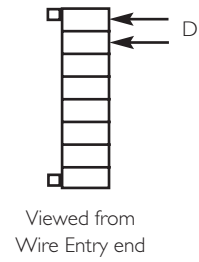
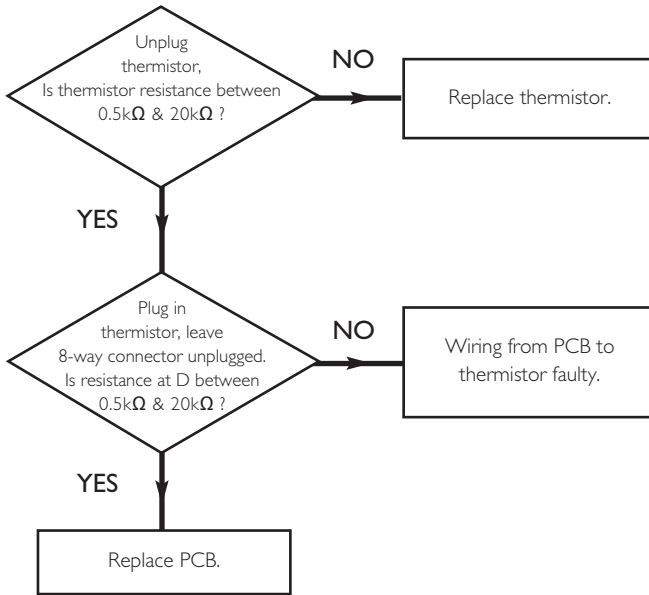

CONDENSATE PUMP

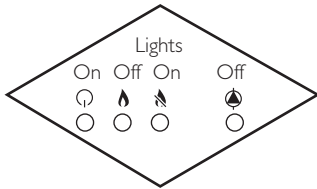

Condensate pump over level switch activated - pump reservoir level too high resulting in ignition lockout.

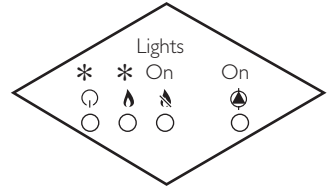

Condensate pump level switch activated for longer than 3 minutes - boiler locks out. Boiler will try to relight 4 times in 5 minutes.

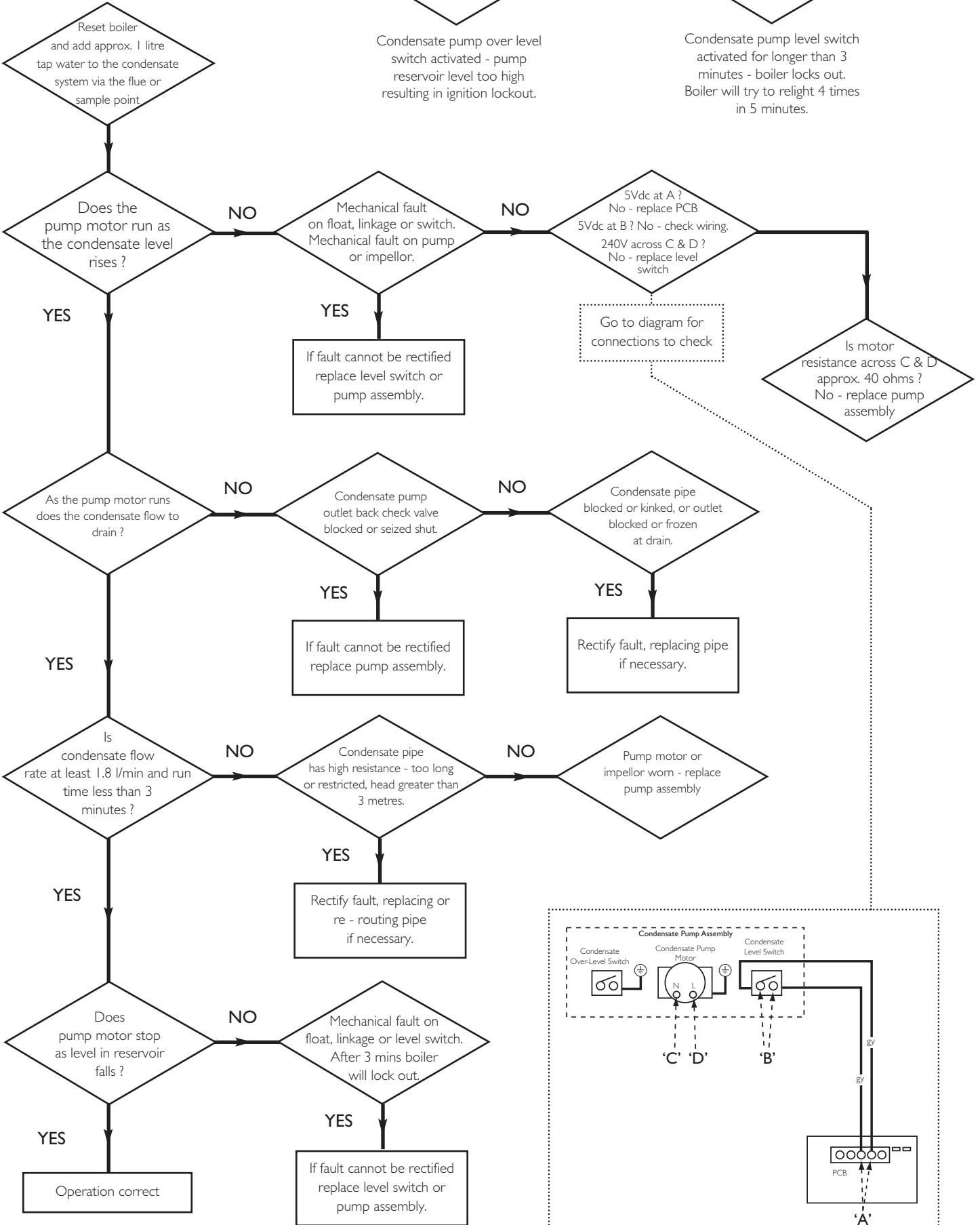



GAS BOILER COMMISSIONING CHECKLIST

BOILER SERIAL No. _____ NOTIFICATION No. _____

CONTROLS To comply with the Building Regulations, each section must have a tick in one or other of the boxes

TIME & TEMPERATURE CONTROL TO HEATING	ROOM T/STAT & PROGRAMMER/TIMER	<input type="checkbox"/>	PROGRAMMABLE ROOMSTAT	<input type="checkbox"/>
TIME & TEMPERATURE CONTROL TO HOT WATER	CYLINDER T/STAT & PROGRAMMER/TIMER	<input type="checkbox"/>	COMBI BOILER	<input type="checkbox"/>
HEATING ZONE VALVES	FITTED	<input type="checkbox"/>	NOT REQUIRED	<input type="checkbox"/>
HOT WATER ZONE VALVES	FITTED	<input type="checkbox"/>	NOT REQUIRED	<input type="checkbox"/>
THERMOSTATIC RADIATOR VALVES	FITTED	<input type="checkbox"/>		
AUTOMATIC BYPASS TO SYSTEM	FITTED	<input type="checkbox"/>	NOT REQUIRED	<input type="checkbox"/>

FOR ALL BOILERS CONFIRM THE FOLLOWING

THE SYSTEM HAS BEEN FLUSHED IN ACCORDANCE WITH THE BOILER MANUFACTURER'S INSTRUCTIONS?

THE SYSTEM CLEANER USED _____

THE INHIBITOR USED _____

FOR THE CENTRAL HEATING MODE, MEASURE & RECORD

GAS RATE m³/hr ft³/hr

BURNER OPERATING PRESSURE (IF APPLICABLE) N/A mbar

CENTRAL HEATING FLOW TEMPERATURE °C

CENTRAL HEATING RETURN TEMPERATURE °C

FOR COMBINATION BOILERS ONLY

HAS A WATER SCALE REDUCER BEEN FITTED? YES NO

WHAT TYPE OF SCALE REDUCER HAS BEEN FITTED? _____

FOR THE DOMESTIC HOT WATER MODE, MEASURE & RECORD

GAS RATE m³/hr ft³/hr

MAXIMUM BURNER OPERATING PRESSURE (IF APPLICABLE) N/A mbar

COLD WATER INLET TEMPERATURE °C

HOT WATER OUTLET TEMPERATURE °C

WATER FLOW RATE lts/min

FOR CONDENSING BOILERS ONLY CONFIRM THE FOLLOWING

THE CONDENSATE DRAIN HAS BEEN INSTALLED IN ACCORDANCE WITH THE MANUFACTURER'S INSTRUCTIONS? YES

FOR ALL INSTALLATIONS CONFIRM THE FOLLOWING

THE HEATING AND HOT WATER SYSTEM COMPLIES WITH CURRENT BUILDING REGULATIONS

THE APPLIANCE AND ASSOCIATED EQUIPMENT HAS BEEN INSTALLED AND COMMISSIONED IN ACCORDANCE WITH THE MANUFACTURER'S INSTRUCTIONS

IF REQUIRED BY THE MANUFACTURER, HAVE YOU RECORDED A CO/CO₂ RATIO READING? N/A YES CO/CO₂ RATIO

THE OPERATION OF THE APPLIANCE AND SYSTEM CONTROLS HAVE BEEN DEMONSTRATED TO THE CUSTOMER

THE MANUFACTURER'S LITERATURE HAS BEEN LEFT WITH THE CUSTOMER

COMMISSIONING ENG'S NAME PRINT _____ CORGI ID No. _____

50 © Baxi Heating UK Limited 2005 SIGN _____ DATE _____

SERVICE INTERVAL RECORD

It is recommended that your heating system is serviced regularly and that you complete the appropriate Service Interval Record Below.

Service Provider. Before completing the appropriate Service Interval Record below, please ensure you have carried out the service as described in the boiler manufacturer's instructions. Always use the manufacturer's specified spare part when replacing all controls

SERVICE 1 DATE

ENGINEER NAME _____
COMPANY NAME _____
TEL No. _____
CORGI ID CARD SERIAL No. _____
COMMENTS _____
SIGNATURE _____

SERVICE 2 DATE

ENGINEER NAME _____
COMPANY NAME _____
TEL No. _____
CORGI ID CARD SERIAL No. _____
COMMENTS _____
SIGNATURE _____

SERVICE 3 DATE

ENGINEER NAME _____
COMPANY NAME _____
TEL No. _____
CORGI ID CARD SERIAL No. _____
COMMENTS _____
SIGNATURE _____

SERVICE 4 DATE

ENGINEER NAME _____
COMPANY NAME _____
TEL No. _____
CORGI ID CARD SERIAL No. _____
COMMENTS _____
SIGNATURE _____

SERVICE 5 DATE

ENGINEER NAME _____
COMPANY NAME _____
TEL No. _____
CORGI ID CARD SERIAL No. _____
COMMENTS _____
SIGNATURE _____

SERVICE 6 DATE

ENGINEER NAME _____
COMPANY NAME _____
TEL No. _____
CORGI ID CARD SERIAL No. _____
COMMENTS _____
SIGNATURE _____

SERVICE 7 DATE

ENGINEER NAME _____
COMPANY NAME _____
TEL No. _____
CORGI ID CARD SERIAL No. _____
COMMENTS _____
SIGNATURE _____

SERVICE 8 DATE

ENGINEER NAME _____
COMPANY NAME _____
TEL No. _____
CORGI ID CARD SERIAL No. _____
COMMENTS _____
SIGNATURE _____

SERVICE 9 DATE

ENGINEER NAME _____
COMPANY NAME _____
TEL No. _____
CORGI ID CARD SERIAL No. _____
COMMENTS _____
SIGNATURE _____

SERVICE 10 DATE

ENGINEER NAME _____
COMPANY NAME _____
TEL No. _____
CORGI ID CARD SERIAL No. _____
COMMENTS _____
SIGNATURE _____

General Enquiries (GB)

Tel. **08706 060 780**

Technical (GB)

Tel. **08706 049 049**

Service (GB)

Tel. **08706 096 096**

Fax. **01926 410 006**

Literature Request (GB)

Tel. **08706 060 623**

Technical (IE)

Tel. **1850 560570**

All descriptions and illustrations provided in this leaflet have been carefully prepared but we reserve the right to make changes and improvements in our products which may affect the accuracy of the information contained in this leaflet. All goods are sold subject to our standard Conditions of Sale which are available on request.

Baxi Heating UK Limited
Browndge Road Bamber Bridge Preston Lancashire PR5 6UP
After Sales Service 08706 096 096 Technical Enquiries 08706 049 049
Website www.baxi.co.uk

A BAXI GROUP company