

Flamingo RS40 and RS50S balanced flue gas fired boiler

INSTALLATION & SERVICE GUIDE

Potterton Flamingo RS40

8.8 to 11.7 kW (30,000 to 40,000 Btu/hr) Output

Potterton Flamingo RS50S

11.7 to 14.7 kW (40,000 to 50,000 Btu/hr) Output

IMPORTANT

This appliance is to be used with Natural Gas only. It must be installed by a competent person as stated in the Gas Safety (Installation and Use Regulations 1984. Leave these instructions adjacent to the gas meter.

* Adjustable length, telescopic balanced flue terminal to suit 9 in. to 15 in. thick walls. A kit (optional extra) is available to increase this to 24 ins.

* Infill side panels (optional extra) are available for boilers mounted with exposed sides.

* Case Extension Kit is provided (optional extra) to house a pump.

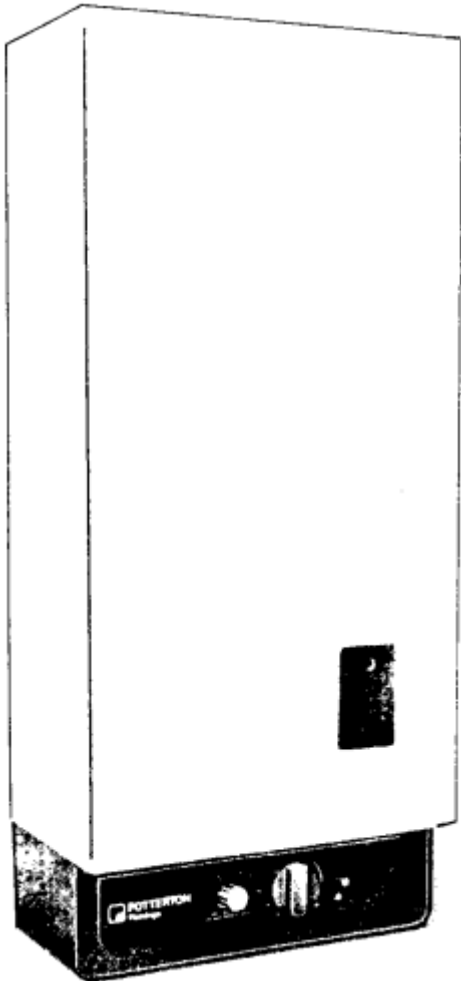

GENERAL Potterton Flamingo room sealed appliances are auto-matically controlled and have been designed for combined systems, e.g. small bore or microbore central heating with an indirect domestic hot water supply which can either have pumped or gravity circulation. These boilers can also be used on a pumped central heating or domestic hot water only system.

DESCRIPTION See Figure 1 and 3.

The boiler is a slim, space saving appliance which must be installed on the inside of an external wall, either in a kitchen or utility room or inside a suitably ventilated purpose designed or modified compartment. The boilers apart from their controls are enclosed in a white, stove enamelled, sheet steel casing. The controls are mounted beneath the casing in a drawer shaped saluki-bronze cover. Side panels, to blank off the space between the boiler and the wall are available as optional extras. Also available as an optional extra, is a casing extension which is fitted on top of the existing boiler casing to enclose a circulating pump and its pipework.

HEAT EXCHANGER

RS50S

The heat exchanger consists of individual cast iron sections which are jointed with 'O rings and bolted together to form flueways and water-ways. The heat exchanger has flow connections at the top and return connections at the bottom, located at the rear of the assembly. The boiler thermostat phial is fitted at the front of the boiler in a pocket screwed into the section. The flue hood, mounted on top of the heat exchanger, directs the flue gases into the balanced flue ducting from where the gases are vented to atmosphere through the terminal on the outside wall of the building.

RS40

The heat exchanger is a single 'Monobloc' casting which features two finned flueways and three waterways, with two flow connections and two return connections. The boiler thermostat phial is located in a pocket at the front, upper left hand side of the heat exchanger. A flue-hood mounted on the top of the heat exchanger, directs the flue gases through the boiler backplate into the balanced flue ducting, from where gases are vented to atmosphere through the terminal on the outside wall of the building.

COMBUSTION CHAMBER AND BURNER

The combustion chamber is a welded rectangular shaped box secured to the under-side of the heat exchanger. A removable cover on the front of the chamber gives access to the laterally mounted single bar, aerated main burner. A bracket which supports the right-hand end of the main burner, also mounts the pilot burner, thermocouple and ignition electrode (on Flamingo RS50S boiler the pilot mounting bracket is attached to the burner). The combustion chamber has an opening at the top to allow the products of combustion to pass through the heat exchanger, and another in its rear face to let in fresh air from the air duct at the rear of the boiler: the air duct connects to the air inlet of the balanced flue terminal.

BOILER CONTROLS

The control system situated at the base of the appliance has been simply designed and is fail safe and easy to operate. It consists of a multifunctional gas control which includes a thermoelectric flame failure device controlled from a thermocouple and pilot burner. The main burner is controlled electrically by a boiler thermostat and a solenoid incorporated into the multifunctional control. Ignition of the pilot burner is by operation of a Piezo-Electric.

THE SYSTEM See Figures 6 to 10

The boiler can be installed in most types of system but the following notes are given as a general guide. The general recommendations given in BS. 5376 and BS. 5449 Part 1 should be observed.

1. All system should be designed so that the static head of the boiler is between a minimum 90mbar (3ft/w.g.) and a maximum. of 2.7bar (90ft/w.g.), except for fully pumped systems where the cold feed is connected into the spare return tapping on the boiler in which case, the static head can be reduced to 1 ft/w.g. (For use in flats and maisonettes).
2. If the head is at or near the minimum 90mbar (3ft/ w.g) extra care should be taken when designing the system to ensure that pumping over or sucking down at the vent pipe cannot occur.
3. All gravity systems should have a minimum effective height of 1.2m (4ft) between the centre line of the boiler heat exchanger and the centre line of the domestic hot water cylinder
4. Most types of system controls, such as two-way valves, three-way valves, diverter valves, twin pumps, zone valves and room cylinder and frost thermostats can be used in conjunction with this boiler.
5. It is recommended that an indirect domestic hot water cylinder is used incorporating a coil type of heat exchanger, In a fully pumped system, the primary pipework should include a lock shield valve.
6. The circulating pump should be selected with reference to [Figure 2](#). The resistance through the boiler heat exchanger will not exceed 20mbar (8in/w.g.) at a flow rate of 4 gall/mm. for RS40 boilers. For RS50S boilers the heat exchanger resistance is considerably lower.
7. The resistance through any other type of system control such as a three-way, valve should also be taken into account when selecting the pump: refer to their manufacturers literature.
8. The circulating pump may be fitted on either the flow or return side of the boiler. If fitted on the flow and the open vent pipe is located between the boiler and the pump, the risk of air being drawn into the system is reduced. If fitted on the return, the cold feed pipe should be connected between the pump and the boiler, but extra care should be taken to ensure that air will not be drawn into the system. Ideally the static head on the inlet side of the pump should be at least a third of the maximum pump duty.
9. A drain cock(s) should be fitted at the lowest point(s) in the system, so that the whole system can be drained.

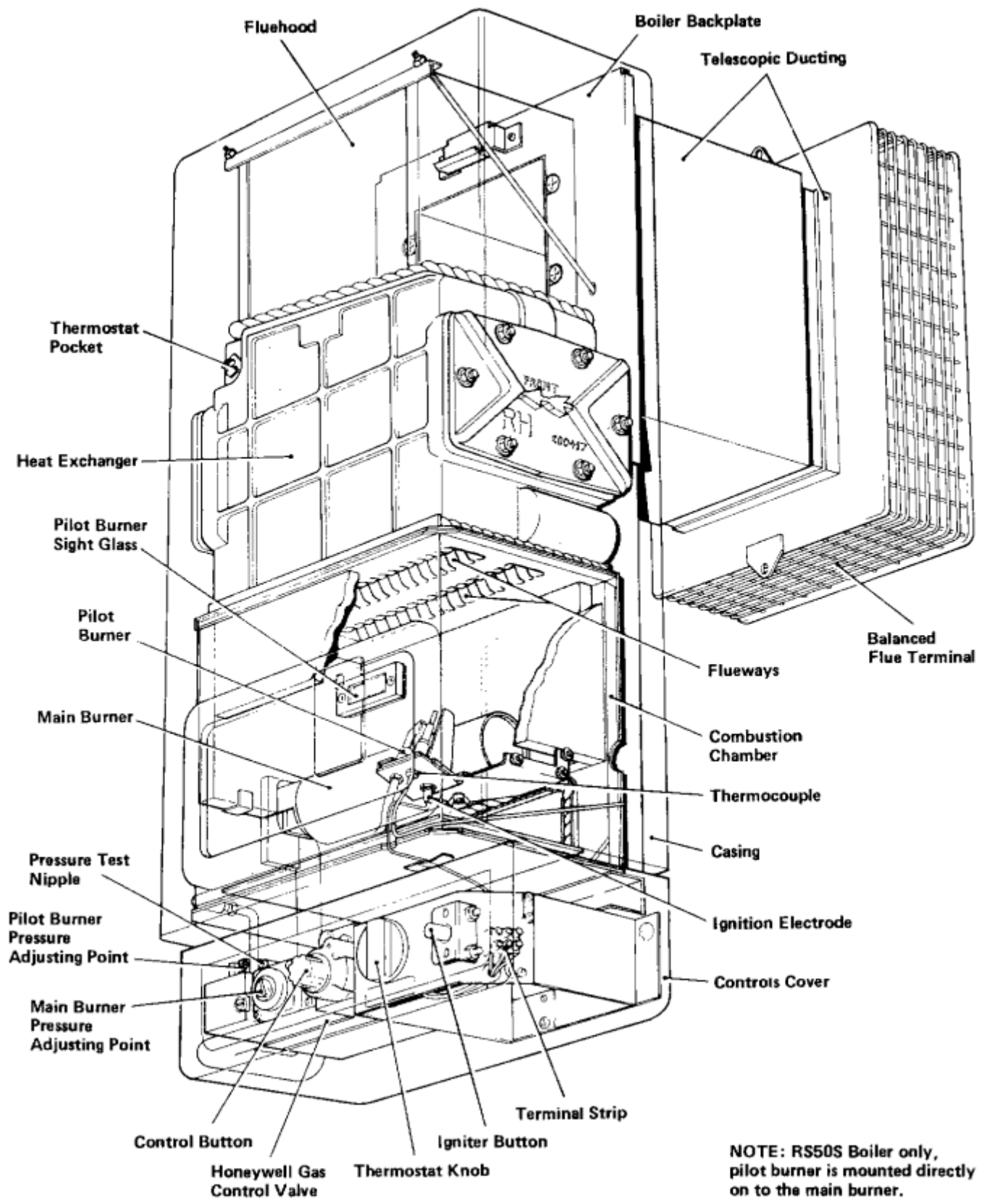

FIG. 1 GENERAL ARRANGEMENT
 Flamingo RS40 illustrated.
 Flamingo RS50S has a sectional heat exchanger.
 Page 3

BOILER MOUNTING SURFACE

The appliance must be mounted on a flat wall of noncombustible material which will not reverberate and is sufficiently robust to take the weight of the boiler. Local Authority and Building Regulations must be observed.

CLEARANCES AROUND THE BOILER

Any position selected for the boiler must give the following minimum clearances for installation and maintenance:

610mm (2ft.) at the front

50mm (2in.) at the top - except where the optional pump casing is to be fitted, when 178mm (7in.) must be allowed.

150mm (6in.) at the bottom

5mm (1/5in.) at each side.

All pipes can be run behind the boiler within its casing width. All connections should be pre-piped with short lengths of pipe, long enough to clear the extremities of the boiler casing. On the RS4O boiler the flow connection(s) can be made from above, below or from the left-hand side when viewed from the front: return connection(s) can be made from above, below or from the right. Connections on the RS5OS boiler can be made from either side to both flow and return ports, equally connections can be made from above and below the appliance. Pipe-work cannot be run from left to right behind the boiler, although it can run from one side to the other immediately above or below the air duct, where in most cases it would be hidden.

VENTILATION

If the boiler is to be installed in a confined space such as a cupboard, the space will need ventilating. Openings should be provided at the top and bottom of the cupboard, each having a free area of RS5OS 175 sq.cm. (27 sq.in.) RS4O 138 sq.cm. (21 sq.ins.). Where the openings draw air direct from outside the building the size of the free areas can be halved. Purpose designed, permanent air vents are not required in the room in which the boiler is installed, whether or not it is in a cupboard. Refer to BS.5376 Part 2 for further information.

Any internal surface of the cupboard that is made of a combustible material and is nearer to the boiler than 75mm (3ins.) should be insulated as described in British Gas publication Material and Installation Specification for Domestic Central Heating and Hot Water.

BALANCED FLUE TERMINAL

The correct positioning of the balanced flue terminal on the outside wall of the building is important. It should not be near any obstruction such as a balcony, drain or stack pipe and it must not be sited near the corner of a building.

Where the terminal has to be positioned near an obstruction, it is advisable to extend the terminal within its limits so that its grille clears the line of the obstruction: when this is necessary, a false wall should be built around the terminal box. The terminal must not be located where its discharge could enter an open door or window, or cause a nuisance in a public right of way. It is advisable to have a minimum of 600mm (2ft.) of flat wall space all around the terminal.

If the terminal discharges at a low level, a terminal guard, supplied, as an optional extra, should be fitted. All installations should conform with the Local Authority and Building Regulations and British Standard Code of Practice. BS.5440 Part 1.

ELECTRICAL SUPPLY

A 240 volts A.C., 50Hz single phase electricity supply fused to 3 amperes must be provided in accordance with the latest edition of the Institute of Electrical Engineers Regulations for the Electrical Equipment and Local Authorities and British Gas Requirements.

The current rating of the wiring to the boiler must exceed 3 amperes, in accordance with BS.6500 1975 and having a cross sectional area of at least 0.75 sq. mm. The supply to the boiler and its associated equipment should be controlled by an unswitched plug and socket or a double pole switch, so that complete isolation from the supply can be achieved to enable maintenance work to be carried out in safety.

GAS SUPPLY

The gas meter and supply pipe should be checked to ensure that they are large enough for the boiler and any other appliance already installed; the local Gas Regional Office will assist in this matter. The recommendations of CP. 331 Parts 2 and 3 should be observed.

SAFETY VALVE

If the Local Authorities Regulations stipulate that a safety valve should be fitted, this should be installed in the flow pipework as close to the boiler as possible.

SERVICING

Servicing is a simple matter as once the casing has been removed all parts that are likely to require servicing are easily accessible.

SETTING UP

Each boiler has to be adjusted once it is installed and this is a skilled job which should only be undertaken by suitably qualified Engineers. Potterton International offer this service on a changeable basis.

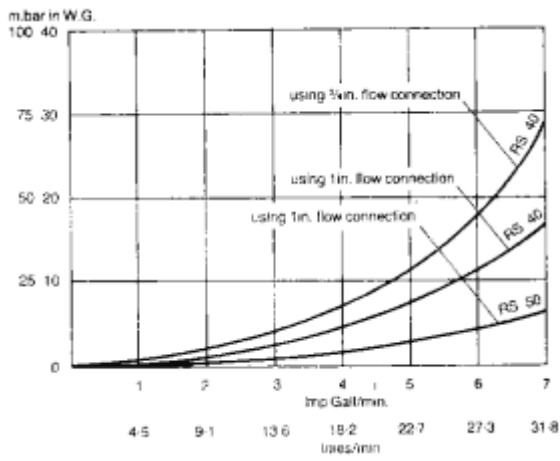

FIG. 2 PRESSURE LOSS ACROSS BOILER
Page 4

DATA SECTION – Page 5

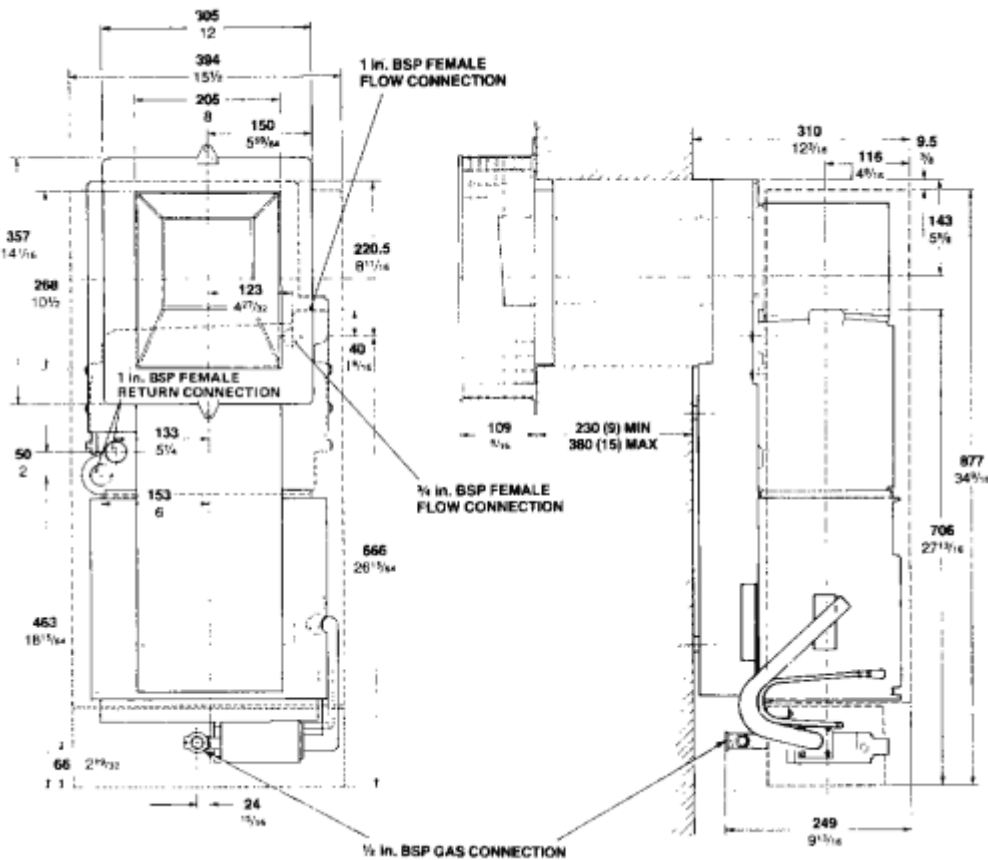

FIG. 3A CONNECTIONS AND DIMENSIONS RS40

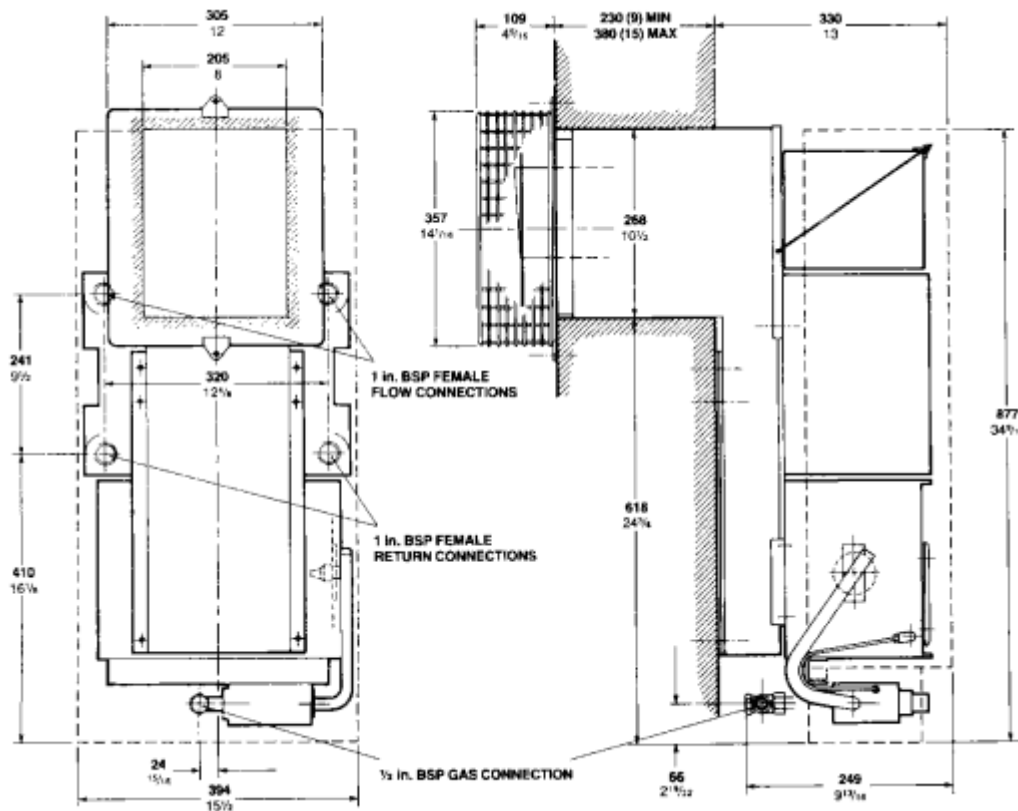

FIG. 3B CONNECTIONS AND DIMENSIONS RS50S

DATA SECTION – Page 6

ADDITIONAL CONTROLS

Potterton Electronic Programmers are available as optional extras. These electronic programmers have been developed to compliment your boiler and offer the user a variety of programmes to suit individual requirements and systems. They are attractively styled with a constant digital clock display, slider and push buttons which are easy to use and understand. This control is fully described in its own Data Sheet which is available on request.

LITERATURE

The following literature is supplied with each boiler:

Data and Installation Instructions/ Servicing Guide

Users Guide Card

NOTE: Illustrated parts catalogues for these boilers are available to installers and servicing agents on request to Potterton International Limited, Brooks House, Coventry Road, Warwick CV34 4LL.

GENERAL DATA

Table 1

	RS40	RS50S
Input	11.6 to 15.2kW (39,500 to 52,000 Btu/h)	15.6 to 19.2kW (53,000 to 65,500 Btu/h)
Output into Water	8.8 to 11.7kW (30,000 to 40,000 Btu/h)	11.7 to 14.7kW (40,000 to 50,500 Btu/h)
Output into Air (approx)	0.7 to 0.9kW (2,400 to 3,100 Btu/h)	0.8 to 0.9kW (2,800 to 3,100 Btu/h)
Water Content	5.6 litres (10 pints)	8.2 litres (1.8 gall.)
Weight (Empty)	75.4 kg (166lb)	77 kg (170 lb)
Burner Pressure	6.0 to 10.5 mbar (2.4 to 4.2 in.wg.)	10.8 to 16.1 mbar (4.3 to 6.5 in.wg.)
Injector Size	3.35 mm dia.	3.35 mm dia.
Gas Rate	1.12 to 1.47 m ³ /h 39.5 to 52.0 ft/h	1.5 to 1.85 m ³ /h 53.0 to 65.5 ft/h
BG.No.	41.601.25	41.601.43
Potterton Code	G.T.F.	G.T.W.

RS40		RS50S	
Max. Working Head:	2.7 bar (90ft/wg.)	Max. Working Head:	2.7 bar (90ft/wg.)
Main Gas Cock:	RC ½ (½in. B.S.P.) loose key	Main Gas Cock:	RC ½ (½in. B.S.P.) Loose key
Electrical Connections:	3 - way terminal block on control panel	Electrical Connections:	3 - way terminal block on control panel
Combination Gas Control:	½in. B.S.P. Honeywell Com-pact V4, 600A 1023	Combination Gas Control:	½in. B.S.P. Honeywell Com-pact V4, 600A 1023
Thermostat:	Ranco C26	Thermostat:	Ranco C26
Main Burner:	Furigas	Main Burner:	Furigas
Pilot Burner:	Honeywell Q314A	Pilot Burner:	Honeywell Q314A
Pilot Ignitor:	Vernitron with Buccleugh Electrode	Pilot Ignitor:	Vernitron with Buccleugh Electrode

Page 6

INSTALLATION SECTION – Page 7

INSTALLATION INSTRUCTIONS

The installation of the boiler must be in accordance with the relevant requirements of the Gas Safety Regulations, Building Regulations, IEE Regulations and the byelaws of the local Water Undertaking.

It should be in accordance also with any relevant requirements of the local gas region and local authority and the relevant recommendations of the following British Standard Codes of Practice:

- CP 331 Installation of pipes and meters for town gas.
Part 3 Low pressure installation pipes.
- BS 5376 Selection and installation of gas space heating (1st and 2nd family gases)
Part 2 Boilers of rated input not exceeding 60kW.
- BS 5449 Central heating for domestic premises
Part 1 Forced circulation hot water systems
- CP 342 Centralized hot water supply
Part 1 Individual dwellings
Part 2 Buildings other than individual dwellings.
- BS 5440 Flues and air supply for gas appliances of rated input not exceeding 60kW (1st and 2nd family gases)
Part 1 Flues
Part 2 Air supply.

1. UNPACKING

a. The appliance will arrive on-site packed in two cartons as follows:

Carton No. 1

- The casing
- The air duct
- The balanced flue terminal
- Controls cover
- Accessory screw pack A, B, D, E, F and G
- Flue hood attaching parts
- Flue hood
- Literature
- The boiler backplate

Carton No. 2

The boiler assembly and the gas cock.

b. Open Carton No. 1. There is no need to open the boiler carton at this stage.

2. FITTING THE AIR DUCT TO THE WALL-

See [Figure 4](#)

a. Decide on the most suitable position for the boiler, taking into account the information given previously, paying particular attention to the siting of the balanced flue terminal on the outside wall of the building. It is a good idea to offer the air duct up to the wall and draw a pencil mark around the duct where it will go through the wall.

- b. Cut a clearance hole in the wall for the terminal ducting; the size of the ducting is 268mm (10 ½ in.) high and 205mm (8in.) wide.
 - c. Measure the thickness of the wall, slide the loose air duct 'A' into the main air duct 'B' and adjust the length to suit the wall thickness plus 94 mm. Seal the ducting joint with self adhesive tape (supplied) see [Figure 4](#). N.B. The overall duct measurement X is taken from the rear face of the duct 'B' to the front face of duct 'A'.
 - d. Temporarily position the boiler air duct against the wall, with its horizontal section inside the wall. Use a spirit level to ensure that the air duct is square and level.
 - e. Holding the air duct in its final position, mark the position of the four duct mounting screws on the wall. Remove the duct from the wall.
 - f. Drill the four holes and insert wallplugs (accessory pack A).
 - g. Fit the air duct to the wall, using the screws, flat washers and cup washers provided (accessory pack A).
- NOTE: The thickness of the wall plaster in some older properties can be substantial and in these instances, it is recommended that larger securing screws are used than those supplied.

3. FITTING THE BALANCED FLUE TERMINAL

- a. Working from inside and/or outside the building use a suitable sealing material and seal the gap between the duct and the inside of the hole in the wall; ensure an airtight seal is obtained.
- b. Shamfer the plaster sealant as shown in [Figure 4](#) to allow engagement of the balance flue terminal assembly, which should then be pushed carefully up against the brickwork ensuring that the flanges on the wall plate slide over the duct retained in the wall. Secure the terminal to the wall with two screws and wall plugs (Accessory Pack B).
- c. When applicable, fit the terminal guard, supplied as an optional extra, over the terminal grille and secure it to the wall.
- d. Make good the inside surface of the wall.

4. UNPACKING THE BOILER

- a. Open Carton No. 2 containing the boiler.
- b. Remove the boiler from its carton and lay it front face onwards on the floor.
- c. Remove the two bolts from the rear of the heat exchanger. Fit the backplate to the boiler in its correct position, see [Figure 4](#) and secure it using the two bolts.
- d. Turn the boiler assembly over and remove the four screws securing the combustion chamber front cover; remove the cover.

5. PREPIPING THE GAS AND WATER CONNECTIONS

-See [Figures 3](#) and [3a](#)

The boiler has been designed so that all pipework to its connections can be concealed within its own width. This enables cupboards to be positioned close up either side with the pipework leaving the boiler at the top and/or bottom as required.

Installation Section – Page 8

Because the pipework connections are behind the boiler backplate, short lengths of pipe should be connected to the appropriate tapings before the boiler is lifted into position, and terminated just clear of the boiler for connecting to the system pipework. It is recommended that capillary fittings are used.

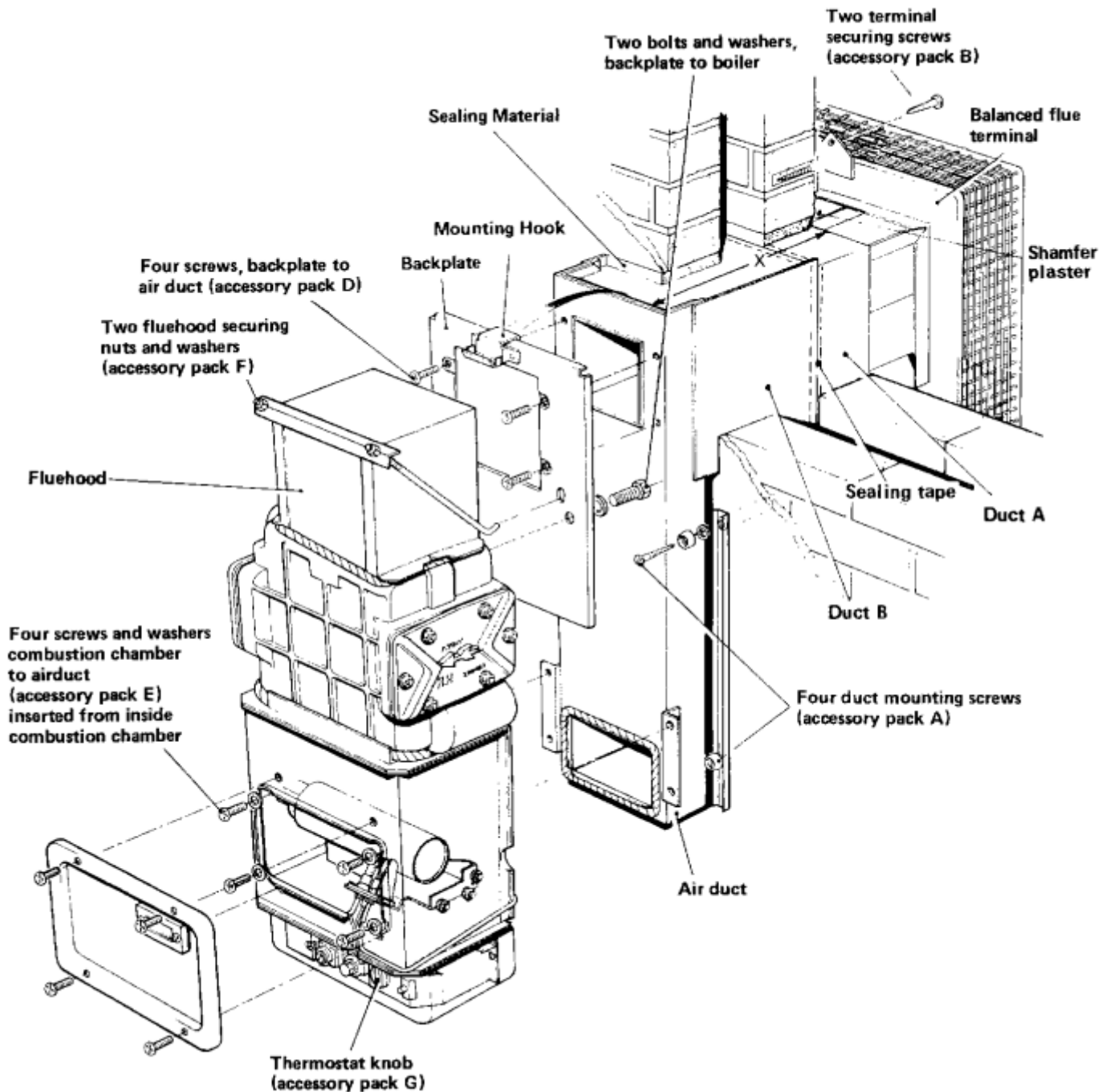

FIG. 4 MOUNTING FEATURES
(Flamingo RS40 illustrated)

Page 8

Installation Section – Page 9

A Combined Gravity System

RS50S

1. Connect a suitable length of 28mm pipe with 90° elbow to either the R.H. or L.H. 1" B.S.P. rear facing flow connections. (Hot water)
2. Connect a suitable length of 22mm pipe with 90° elbow to the remaining 1" B.S.P. rear facing flow connection. (Central heating)
3. Connect a suitable length of 28mm pipe with 90° elbow to either the R.H. or L.H. 1" B.S.P. rear facing return connections. (Hot water)

4. Connect a suitable length of 22mm pipe with 90° elbow to the remaining 1" B.S.P. rear facing return connection. (Central heating)

NOTE: Ensure that the fittings at the rear of the boiler do not protrude more than 92mm from the boiler backplate or they may foul the wall.

RS40

1. Connect a suitable length of 28mm pipe to the 1 in. B.S.P. upwards facing domestic hot water flow connection on top of the heat exchanger.

NOTE: The flow pipe must be turned through 90° and routed through the cut-out in the back-plate, ensuring it is kept within the confines of the cut-out. It must not project above or to the side of the backplate, otherwise it will be impossible to fit the casing.

2. Connect a suitable length of 22mm pipe to the ¾ in. B.S.P. rear facing central heating flow connection. There is room to split the flow behind the boiler if required. The circulating pump can be fitted on either the flow or return, above or below the boiler; refer to '[The System](#)', and the pump manufacturers instructions.

3. Connect a suitable length of 28mm pipe to the upper 1in domestic heating return connection.

4. Connect a suitable length of 22mm pipe to the lower 1in. central heating return connection.

NOTE: Ensure that the fittings to the return connections do not protrude more than 92mm from the boiler backplate, or they may foul the wall.

B Fully Pumped System or Pumped Central Heating Only

RS50

1. Connect a suitable length of 22mm pipe with elbow to either the R.H. or L.H. 1in B.S.P. rear facing flow connections. The vent pipe should be connected into the flow pipe as close to the boiler as possible. Blank off the remaining flow connection.

2. Connect a suitable length of 22mm pipe with elbow to either the R.H. or L.H. 1in B.S.P. rear facing return connections.

3. The remaining connection can be blanked off or used to connect the cold feed.

4. The circulating pump can be fitted in any position on either the flow or return to suit the particular installation.

Refer to '[The System](#)' and 'Pump Manufacturer's Instructions'.

RS40

1. Connect a suitable length of 22mm pipe to the 1in B.S.P. upwards facing combined flow connection on top of the heat exchanger. The vent pipe should be connected into the flow pipe as close to the boiler as possible. Blank off the ¾ in. B.S.P. rear facing flow connection. If it is necessary to use this ¾ in. B.S.P. flow connection a 22mm pipe should be connected to it and the 1in. B.S.P. connection used for the vent pipe.

NOTE: The flow pipe must be turned through 90° and routed through the cut-out in the back-plate, ensuring it is kept within the confines of the cut-out. It must not project above or to the side of the backplate, otherwise it will be impossible to fit the casing.

2. Connect a suitable length of 22mm pipe to the lower 1in return connection.

3. The upper 1in return connection can either be blanked off or used to connect the cold feed.

4. The circulating pump can be fitted in any position on either the flow or return to suit the particular installation.

Refer to '[The System](#)' and the 'Pump Manufacturer's Instructions'.

C Boiler Main Gas Cock

1. The main gas cock is supplied loose and must be fitted directly to the union nut and liner already assembled to the inlet pipework on the boiler. The gas cock must be located in the most suitable position for operation, e.g. with its operating plug facing towards the side of the boiler.

2. Connect a suitable length of 15mm pipe to the gas cock, terminating it in a length which can be easily connected to the main supply, once the boiler is in position on the wall.

6. FITTING THE BOILER ON THE WALL

a. Stand the boiler on the floor in a vertical position, so that it is supported on its two metal legs. Lift the boiler onto the air duct on the wall, locating the hook at the top of the boiler backplate, over the top edge of the duct.

b. Secure the boiler backplate to the air duct with the four screws adjacent to the flue hood position (Accessory Pack D). Secure the combustion chamber to the air duct with the four screws with washers (Accessory Pack E), inside the combustion chamber.

NOTE: Accessibility for fitting the four screws inside the combustion chamber will be improved if the main burner is first removed.

c. Fit the fluehood to the boiler, using tie-rods which located either into holes in the back plate RS40 or holes in the return edge of the backplate RS50S and angle strap, see [Figure 4](#), securing it with the two nuts and washers (Accessory Pack F); ensure an air tight seal is obtained between the fluehood, the top of the heat exchanger and the backplate.

d. Fit the combustion chamber front cover, securing it with the four screws; ensure a gas tight seal is obtained.

- e. Undo the capillary coil of the thermostat and teed phial into thermostat pack in H.E. Ensure that routing of capillary is clear of the case.
- f. Connect the main gas supply to the length of pipe fitted to the boiler main gas cock. Ensure that the tap is in a position suitable for its operation.

Page 9

Installation Section – Page 10

- g. Connect the short lengths of pipe, previously fitted to the water flow and return connections, to the system pipework.
- h. Open all water valves and thoroughly flush the system.
- i. Fill and vent the water system and test for leaks, rectify if necessary.
- j. Unscrew the nuts and remove and discard the two metal legs at the bottom of the boiler.

7. WIRING - See Figures 5 to 11

Care must be taken to ensure that all wiring to the boiler is kept clear of sharp edges and hot surfaces.

The boiler terminal strip is not designed to accept wiring from all the on-site system controls and therefore, the installer will need to incorporate a suitable junction box. The principle of wiring the boiler and its controls is shown in [Figure 5](#). However, the layout of a particular system will itself govern the most economical location for the junction box and its terminals.

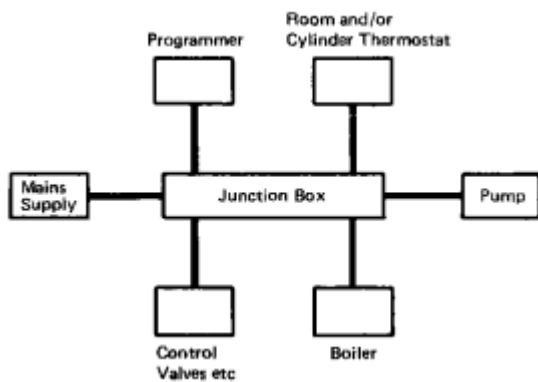

FIG. 5 PRINCIPLE OF WIRING

Wire the boiler and system controls as illustrated in

Figures [7,8,9, 10 and 11](#) depending on the type of system installed. The wiring arrangements shown outline only the basic control requirements, and will therefore require on-site interpretation of the various boiler installation arrangements.

[Figure 10](#) illustrates a system with a zone valve which requires an electrical supply to motor it both to the open and closed positions. Zone valves which require an electrical supply to open them but not to close them, should be wired in a similar manner but ignoring the closed connection from the room thermostat. For this type of valve, a room thermostat with a single pole contact should only be used. Certain zone valves may require an additional connection to the auxiliary switch (shown dotted). This would apply to those valves which internally are not suitable for giving an open signal from the normal opening voltage supply.

If a Potterton EP 2000/3000 Programmer time control is not being fitted, but a three terminal time clock is to be installed to control the systems illustrated in Figures [7,8,9, 10 or 11](#) the time clock should be wired as follows:

Live to Time Clock Live

Neutral to Time Clock Neutral

Earth to Time Clock Earth

Wires normally connected to EP 2000/3000

Programmer Terminals 3 and 4 to Time Clock Switch

A low limit thermostat can be installed to override the 'OFF' setting of the time control. Where an EP 2000/ 3000 or equivalent Programmer is installed, a double pole thermostat or a single pole thermostat with change over contacts may be necessary; for the electrical connections and type required, see the relevant system wiring diagram. Where only a time clock is fitted, the thermostat need only be a single pole type with its contact wired in parallel with the clock switch.

If a three way (proportioning diverter) valve with a mid-position is being fitted in the system, the following instructions must be adhered to in addition to the valve manufacturers wiring information.

1. Neutral and earth connections must be made to boiler terminals N and E.
2. The switches supply from the system control circuit must be connected to boiler terminal L.
3. The live supply to the pump must be taken from the supply to boiler terminal L.

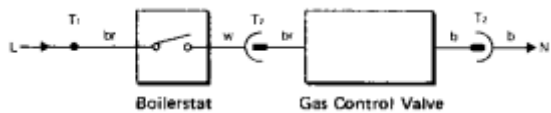
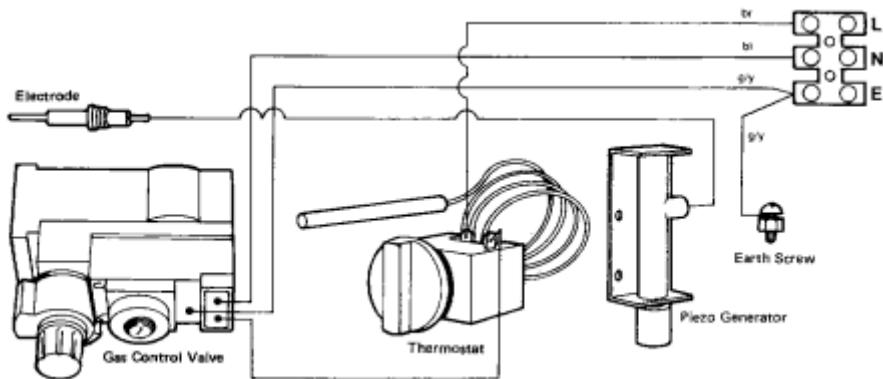
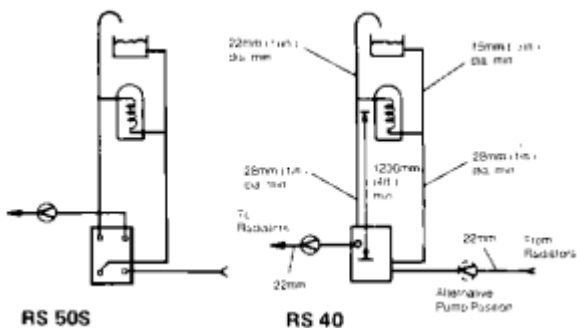

FIG. 6 BOILER WIRING DIAGRAM



Installation Section – Page 11

FIG 7 GRAVITY HOT WATER WITH PUMPED CENTRAL HEATING



RS 50S

RS 40

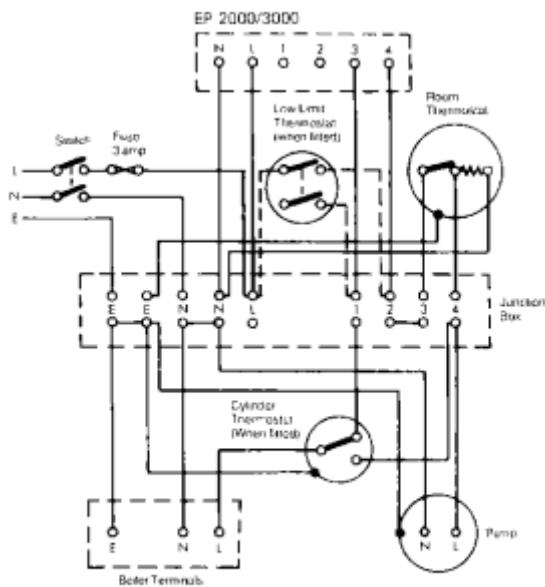

Note: When a cylinder thermostat is not fitted, a direct connection must be made between junction box terminal 1 and boiler terminal L.

GRAVITY HOT WATER WITH PUMPED CENTRAL HEATING

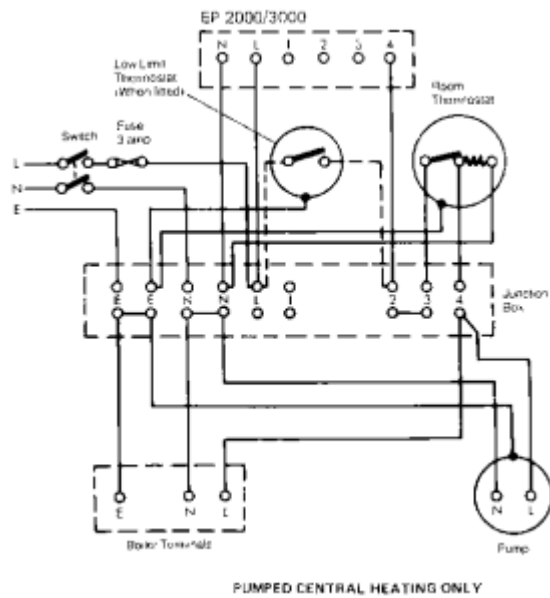

PUMPED CENTRAL HEATING ONLY

FIG 8 GRAVITY HOT WATER WITH TEMPERATURE CONTROLLED AND PUMPED CENTRAL HEATING

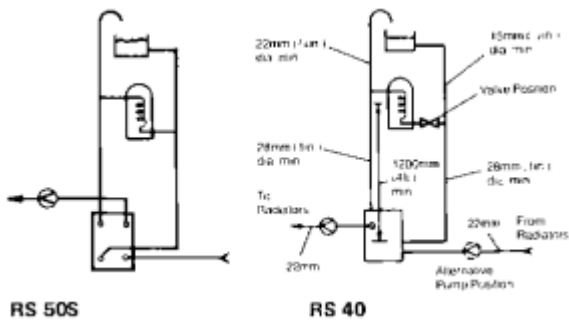

RS 50S

RS 40

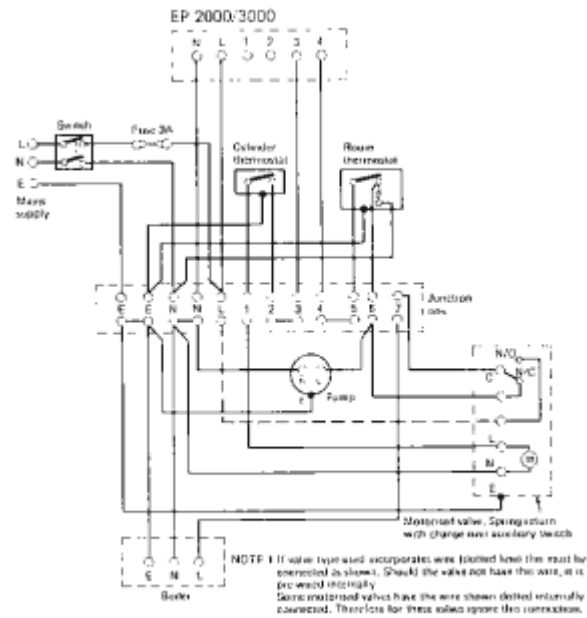

NOTE 1 If valve type used incorporates a dotted lead the rest for connection is shown. Should the valve not have this wire, it is provided internally. Some motorised valves have the wire shown dotted internally connected. Therefore for these valves ignore the connection.

GRAVITY HOT WATER WITH TEMPERATURE CONTROL AND PUMPED CENTRAL HEATING, ALTERNATIVE WIRING DIAGRAM

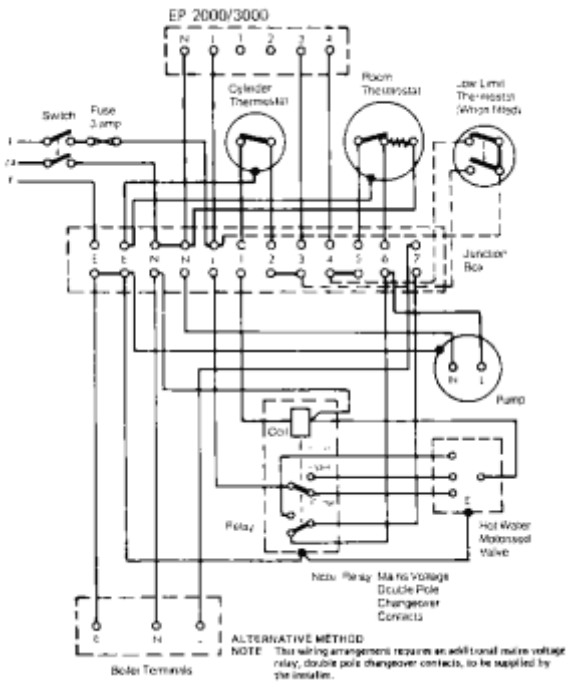

Installation Section – Page 12

FIG 9 FULLY PUMPED WITH TWO POSITION DIVERTER VALVE

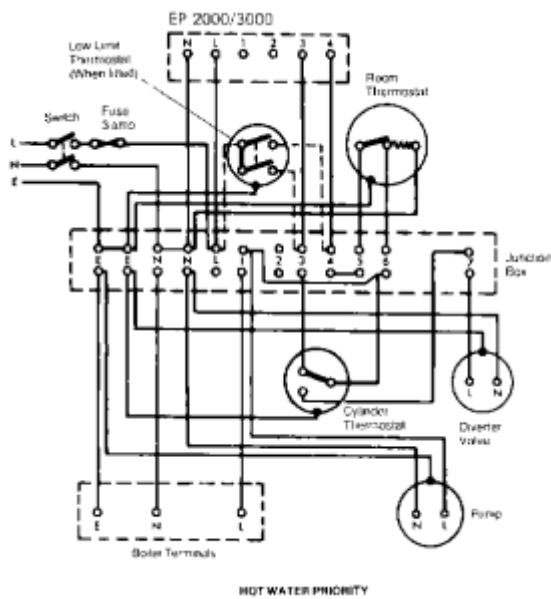
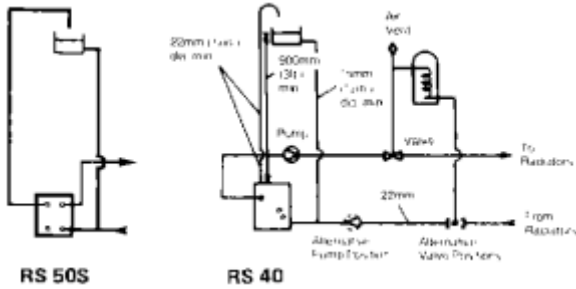

NOTE: The minimum 900mm (3ft.) static head shown in figs. 9, 10 and 11, and mentioned in Section 1 in ‘[The System](#)’ on page 2, can be reduced to 300mm (1ft.) providing the cold feed is connected directly into the spare return tapping on the boiler. A static head of less than 300mm (1ft.) should not be used.

NOTE: These system diagrams, figs. 7 to 11, are schematic only. Installers are recommended to read "[The System](#)" on page 2 and BS5376 and BS.5449 Part 1.

FIG 10 FULLY PUMPED WITH ONE OR TWO TWO-WAY VALVES

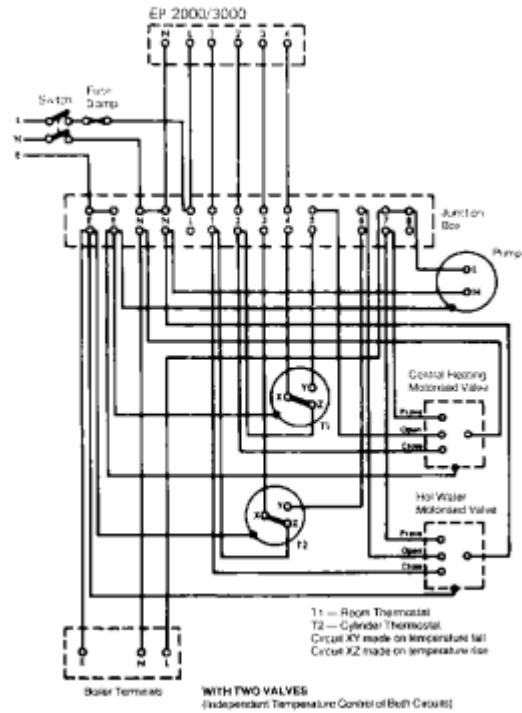
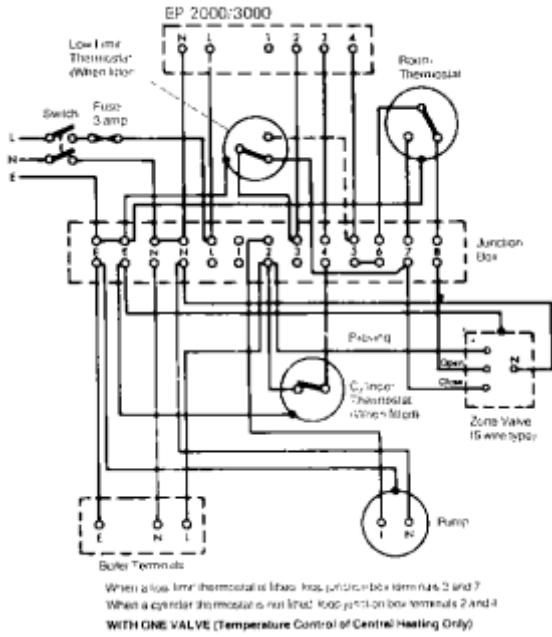
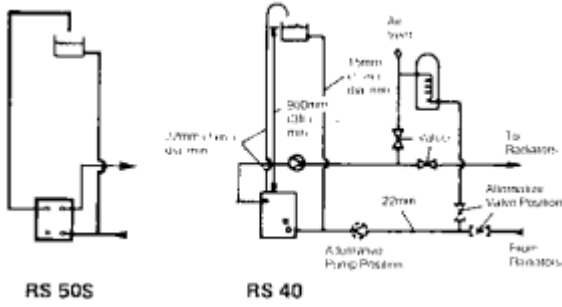
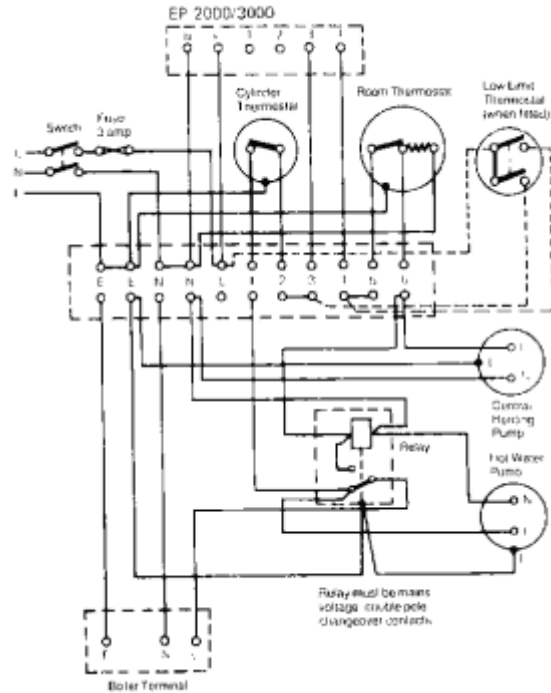
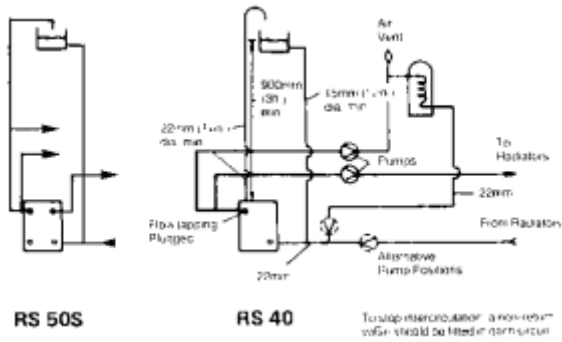

FIG. 11 FULLY PUMPED USING TWO PUMPS



8. FIRST LIGHTING

Before lighting the boiler, the gas installation must be tested for soundness in accordance with CP331 Part 3 1974. The electrical installation must be checked as follows:-

8.1 PRELIMINARY ELECTRICAL SYSTEM CHECKS See Figures 6 and 12

A. Earth Continuity Check - appliance must be electrically connected - meter set on Ω ; (ohms) x 1 scale and adjust to zero if necessary.

a) Test leads from any appliance earth point to earth pin on plug resistance should be less than 1 Ω ; (ohm). If the resistance is greater than 1 Ω ; (ohm) check all earth wires for continuity and all contacts clean and tight. If resistance of earth is still greater than 1 Ω ; (ohm) then this should be reported to your supervisor.

B. Short Circuit Check - appliance electrically disconnected, all switches ON including stats.

a) Meter set on Ω ; (ohms) x 1 scale.

Test leads from L to N in appliance terminal strip/ block - if meter reads '0' then there is a short circuit.

b) Meter set on Ω ; (ohms) x 100 scale.

Repeat test with leads from L to E. If meter reads less than ∞ ; (infinity) there is a fault.

NOTE: Should it be found that the fuse has failed but no fault is indicated - a detailed continuity check (i.e. by disconnecting and checking each component) is required to trace the faulty component. It is possible that a fault could occur as a result of local burning/arching but no fault could be found under test. However, a detailed visual inspection should reveal evidence of burning around the fault.

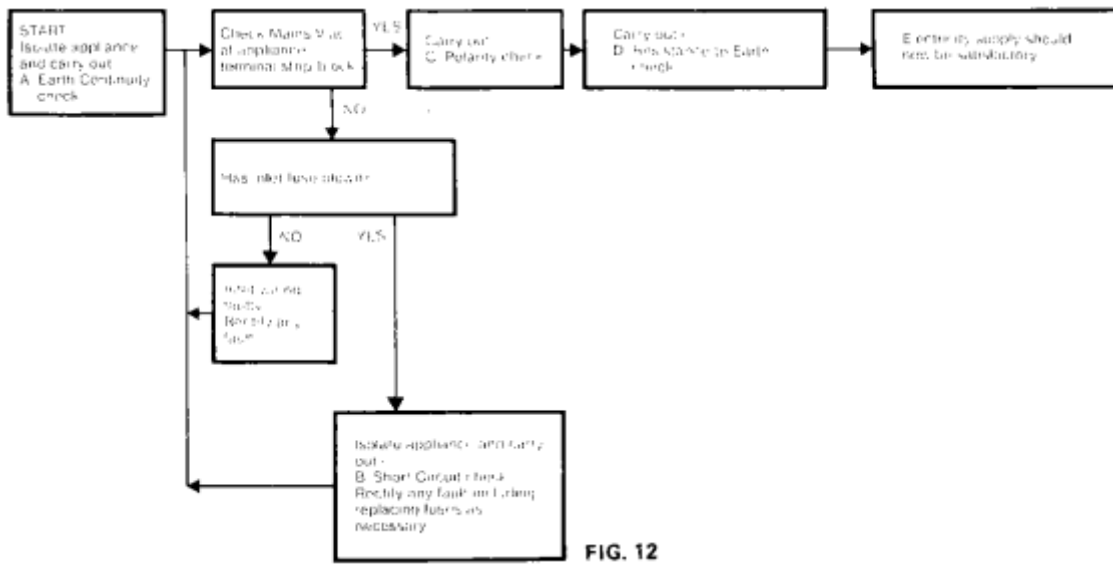

FIG. 12

Installation Section – Page 14

C. Polarity Check

Appliance connected to mains supply and meter set of 300 Vac scale. Test at appliance terminal strip:-

- a) Test leads from L to N - meter reads approx. 240 Vac
- b) Test leads from L to E - meter reads approx. 240Vac
- c) Test leads from N to E - meter reads from 0.15Vac

Thus the terminal marked L is the live terminal. If the low Vac reading is given on terminals other than N to E there is an electrical fault.

Repeat the test at the appliance plug/inlet spur to check the wiring system up to the appliance and rectify any fault. If necessary repeat the test at the supply system socket/spur - if the fault also occurs at this stage then there is a house system fault which requires attention by the Electrical Authority. The customer should be warned not to use the appliance until this examination has been carried out.

D. Resistance to Earth Check

Appliance must be disconnected from mains supply and meter set on ∞ ; (ohms) x 100 scale. All switches including stats, 'On' - Test leads from L to E - if meter reads other than infinity (∞ ;) there is a fault which should be isolated. A detailed continuity check is required to trace the fault component.

IMPORTANT

This series of checks are the first electrical checks to be carried out during a fault finding procedure. On completion of the service/fault finding task which has required the breaking and remaking of electrical connections then the checks A. Earth Continuity, C. Polarity and D. Resistance to Earth must be repeated.

8.2 TO LIGHT THE BOILER

- a) Fit the boiler thermostat knob (Accessory Pack G) onto its spindle and switch it to the off position.
- b) Check that the main electricity supply to the boiler is switched on.
- c) Turn on the main gas supply.

WARNING: OPEN ALL WINDOWS AND EXTINGUISH ANY NAKED LIGHTS IN THE ROOM AND PUT OUT PIPES AND CIGARETTES.

- d) Break the union adjacent to the boiler main inlet cock, then open the cock and purge any air from the supply pipe.
- e) Close the cock, remake the union then re-open the cock and test for gas soundness using a soap solution.

WARNING: DO NOT USE A NAKED FLAME

- f) Ensure that the system is full of water and that the pump and radiator isolating valves are open.
- g) Ensure that the time control, if fitted, is in an 'on' condition, and that the room and/or cylinder thermostats, where fitted, are set to high temperatures.
- h) Turn the control button on the gas control valve clockwise as far as possible (approximately 1/12th of a turn) and release it. This ensures the valve is in the off condition.

i) Press and hold in the control button on the gas control valve, then press in the igniter button until a click is heard. Release the igniter button but continue to hold in the control button and check through the sight hole that the pilot has lit: hold in the control button for a further 20 seconds, then release it and the pilot should remain alight.

NOTE: On first lighting, establishment of the pilot flame may be slightly delayed due to the presence of air in the pipework and several operations of the igniter button may be necessary.

If the pilot fails to light or goes out at any time, immediately turn the control button clockwise as far as possible (approx. 1/12th of a turn), then release it and wait three minutes before repeating the lighting procedure. The control button should not be touched during this period.

- k) Turn the boiler thermostat on and to a high setting and the main burner will light.

l) Set the boiler thermostat and the room and/or cylinder thermostat(s) and time control, where installed, to their required operating conditions.

9. FINAL ADJUSTMENT

A. Gas Rate and main burner pressure setting

- 1) Fit a pressure gauge to the pressure test nipple on the gas control valve, see [Figure 1](#).
- 2) Turn on the boiler thermostat, then check that the burner pressure is in accordance with [Table 1](#).
- 3) If burner pressure adjustment is necessary, remove the screwed cap on the top of the control valve and turn the screw beneath clockwise to increase pressure or anti-clockwise to decrease. Re-fit the screwed cap when the pressure is correct. Shut down the boiler, remove the pressure gauge and tighten the screw in the pressure test nipple.
- 4) With the burner set to its correct pressure, the firing rate given in [Table 1](#) should also be obtained and this should be checked by meter reading over a period of at least five minutes once the boiler is hot.

B. Pilot Burner

The correct adjustment is achieved when the length of the pilot flame completely envelops the tip of the thermocouple, but the tip itself is still visible. See [Figure 13](#).

When the pilot is set to the above instructions the E.M.F. generated by the thermocouple should be of the order of 18 - 32 my open circuit, 10 - 15 my closed circuit. Drop out should occur between 2 -4 my closed circuit.

C. Boiler Thermostat

1) At its maximum and minimum settings, the thermostat should control the water flow temperature at approximately 55°C - 80°C (130° - 182° F) respectively. This should be checked using preferably a thermometer in the flow pipe or alternatively a 'clip-on' type if one is not fitted.

2) The thermostat has been calibrated by the makers and no attempt should be made to recalibrate it on site. Turn the thermostat to the off position and check that the main burner shuts down.

Page 14

Installation Section – Page 15

D. Combined Control

Solenoid

Check the operation of the valve by turning off the electricity supply, either by the isolating switch or the time control, where installed. The main burner must shut down immediately.

Flame Safety Valve

Check the operation of the valve as follows with the boiler running normally: - Turn the control button clockwise as far as possible and a distinct click should be heard within 60 seconds indicating that the flame failure valve has closed.

E. Remote Controls

Check that any other remote control connected in the system such as time clocks and thermostats, control the boiler as required.

10. CASING

NOTE: Ensure that the electrical supply to the boiler is switched 'off'.

A. Fit the casing to the boiler, locating the tongue inside the casing top, into the trough on the air duct bracket. Secure the case with the two captive screws at its lower edge, and the single captive screw at the top, adjacent to the locating tongue.

B. Remove the thermostat knob, then fit the controls cover in position and secure it with the captive screw. Refit the thermostat knob.

NOTE: The panel on the front of the controls cover, through which the thermostat spindle and the control and igniter button protrude, can be adjusted by a simple sliding action to line up with the controls.

11. USER'S GUIDE

A user's guide is provided with this boiler but if possible, the installer should explain the operation of the boiler and system to the householder.

Page 15

SERVICE SECTION – Page 16

SERVICE INSTRUCTIONS

To ensure continued efficient operation of the boiler it is necessary to carry out maintenance and cleaning at regular intervals.

The frequency of cleaning will depend upon the particular installation conditions and the use to which the boiler is put, but in general, once per year should be adequate.

Before the start of any maintenance, switch off the main electricity supply and disconnect the plug at the main isolating switch and socket. Turn off the boiler main gas inlet cock.

If there has been any delay in cleaning, and the boiler has been switched off, it is desirable to operate the boiler for a short time to dry out deposits in the flueways which, if they are left in the cold state, will absorb moisture and become both corrosive and difficult to remove.

The following notes apply to the boiler and its controls, but it should be remembered that attention must also be paid to the heating circuit itself including radiator valves, thermostats, the time control and the expansion and feed water system. In all cases prior to maintenance, light up the boiler and check that the pilot and main burners have a clean, even flame and that the gas rate and main burner pressure is- correctly set.

NOTE:

Where it is required to break any seal during maintenance, the seal should be examined carefully for damage and if necessary replaced. It is important to obtain the correct Potterton approved part for the seal

replacement which is available from Interpart spares stockists, or where difficulty in supply is experienced, directly from Potterton International Limited.

1. PREPARING THE BOILER

- a. Pull off the boiler thermostat knob, then unscrew the screw securing the controls cover and slide the cover from the boiler.
- b. Unscrew the two captive securing screws at the bottom of the casing and the single captive screw at the top, then withdraw the casing from the boiler.
- c. Unscrew the four screws securing the combustion chamber front cover and remove the cover.

2. MAIN BURNER ASSEMBLY - REMOVAL AND CLEANING

- a. Unscrew the wingnut securing the main burner to the right-hand side mounting bracket inside the combustion chamber. On the Flamingo R5505 boiler, undo the two screws securing the pilot plate to the burner. Lift out the burner taking care not to damage the pilot assembly or insulation. Remove all deposits from the burner.

On the Flamingo RS50S boiler it will be necessary to lift the right hand side of the burner into the top right-hand corner of the combustion chamber so that the burner can clean the injector. By moving the burner forward and to the left, it can now easily be removed.

- b. Do not attempt to refit the main burner assembly into the combustion chamber at this stage, as the flueways in the heat exchanger have to be cleaned first.
- c. Drape a suitable cloth over the pilot burner assembly so that when the heat exchanger is cleaned, the dirt removed does not foul the pilot, ignition electrode or thermocouple.

3. HEAT EXCHANGER

- a. Unscrew the two nuts and remove the hooks and strap. Lift off the fluehood.
- b. Working from above and below the heat exchanger, use a suitable brush and remove all deposits from between the fins of the casting.
- c. Refit the fluehood, ensuring that a good seal is made with both the boiler backplate and the top of the heat exchanger. Tighten the two nuts. Ensure hooks are engaged correctly.
- d. Remove the cloth covering the pilot burner assembly and clean any deposits from the pilot, ignition electrode or thermocouple.

4. MAIN BURNER ASSEMBLY - REPLACEMENT

Replace the main burner in position and secure it with the wingnut. On the Flamingo RS50S boiler it will be necessary to slide the burner into the combustion chamber from the left hand side, lift the leading edge of the burner into the top right hand corner of the heat exchanger and feed the air box over the injector. Secure the burner with the wingnut. Refit pilot plate to bracket on burner, two screws.

5. OTHER BOILER COMPONENTS

No further replacement has to be carried out on any other unit. Repair is by replacement and instructions on this are given later.

6. FINAL ADJUSTMENTS

- a. Refit the combustion chamber front cover and secure it with the four screws. Ensure an air tight seal is obtained all around the edge of the cover.
- b. Fit the thermostat knob onto its spindle.
- c. Connect the pressure gauge to the pressure test nipple on the Honeywell Compact Control Valve ([figure 1](#)).
- d. Switch on the main electricity supply to the boiler and check that the boiler thermostat is in the off position.
- e. Turn on the main gas supply.
- f. Ensure that the system is full of water and that the pump and radiator isolating valves are open.
- g. Ensure that the time control, if fitted, is in an 'on' condition, and that the room and/or cylinder thermostats, where fitted, are set to high temperatures.
- h. Turn the control button on the gas control valve clockwise as far as possible (approximately 1/12th of a turn) then release it. This ensures that the valve is in the 'off' condition.
- j. Press and hold in the start or control button on the gas control valve, then press in the Piezo igniter button but continue to hold in the start or control button and check through the site glass, that the pilot has lit; hold in the start or control button for a further 20 seconds, then release it and the pilot should remain alight.

NOTE: On first lighting, establishment of the pilot flame may be slightly delayed due to the presence of air in the pipework and several operations of the Piezo igniter button may be necessary. If the pilot fails to light or goes out at any time, immediately press in the 'off' button or turn the control button clockwise as far as possible. Wait three minutes before repeating the lighting procedure during which time control valve should not be touched.

k. When correctly set, the pilot flame must be sufficient to heat the thermocouple so that the pilot safety device is 'held in' but must not cause the thermocouple to glow bright red. The correct adjustment is achieved when the length of the pilot flame completely envelops the tip of the thermocouple, but, the tip itself is still visible - see [Figure 13](#). If the pilot needs adjustment rotate the exposed pilot restrictor screw on the gas valve ([Fig. 14](#)) clockwise to reduce or anti clockwise to increase the flame. When the pilot is set to the above instructions, the E.M.F. generated by the thermocouple should be of the order of 18 - 30mv open circuit, 10 - 15 closed circuit. Drop out should occur between 2 - 4mv closed circuit.

l. Turn on the boiler thermostat and the main burner will light. Check that the burner pressure is in accordance with [Table 1](#).

If burner pressure adjustment is necessary, remove the screwed cap from the control valve ([Figure 14](#)) and turn the screw beneath clockwise to increase pressure or anti-clockwise to decrease. Refit the screwed cap when the pressure is correct. Shut down the boiler, remove the pressure gauge and tighten the screw in the pressure test nipple. With the burner set to its correct pressure, the heat input given in [Table 1](#) should also be obtained and this should be checked by meter reading over a period of at least five minutes once the boiler is hot.

7. REMOVAL/REPLACEMENT OF BOILER COMPONENTS

a. Main Burner and Injector

1. Turn off the boiler main gas cock.
2. Switch off the main electricity supply to the boiler.
3. Carry out operations A to C under [1. 'Preparing the Boiler'](#).
4. Unscrew the wingnut securing the main burner to the right-hand side mounting bracket inside the combustion chamber. On the Flamingo RS5OS boiler, undo the screws securing the pilot plate to the burner. Lift out the burner as described in taking care not to damage the pilot assembly or insulation. Remove all deposits from the burner.
5. Unscrew the main burner injector from the left-hand side panel of the combustion chamber. Take care not to lose the washer behind the injector.
6. Replacement is the reverse of removal.
7. Test the boiler as described in [6, 'Final Adjustment'](#).

b. Pilot Burner and Injector

1. Turn off the boiler main gas cock.
2. Switch off the main electricity supply to the boiler.
3. Carry out operations A to C under [1. 'Preparing the Boiler'](#).
4. Pull the tag, on the end of the igniter lead, off the connector on the electrode.
5. Disconnect the pilot supply pipe at the base of the pilot. The pilot injector will drop out.
6. Disconnect the thermocouple from the pilot assembly, then withdraw the thermocouple from the combustion chamber. Ensure that the thermocouple is clean and undamaged.
7. Remove the screws securing the pilot assembly to its mounting bracket, then withdraw the assembly from the combustion chamber. Note: On Flamingo RS4O the pilot shield is separate and is retained by one of the pilot bracket retaining screws.
8. Unscrew the backnut and remove the ignition electrode from the old pilot assembly and fit it to the new one.
9. Replacement is the reverse of removal.
10. Test the boiler as described in [6, 'Final Adjustment'](#).

c. Ignition Electrode

1. Carry out operations (1) to (8) under 'B'. Pilot Burner and Injector, fitting the new electrode to the existing pilot burner assembly.
2. Ensure that the new electrode is correctly fitted and not bent. Check that the distance between the electrode and the hood of the pilot is between 2 and 4 mm.
3. Replacement is the reverse of removal.
4. Test the boiler as described in [6, 'Final Adjustment'](#).

d. Thermocouple

1. Carry out operations (1) to (3) and (6) under 'B' Pilot Burner and Injector.

2. Disconnect the thermocouple lead from the gas control valve, noting the route the lead takes from the combustion chamber. The replacement lead must be routed in a similar manner, so that sharp bends in the lead are eliminated.

3. Replacement is the reverse of removal.

4. Test the boiler as described in [6, 'Final Adjustment'](#)

e. Honeywell Gas Control Valve

1. Turn off the boiler main gas cock.

2. Switch off the main electricity supply to the boiler.

3. Pull off the thermostat knob, then unscrew the screw securing the controls cover to the boiler and slide off the cover.

4. Remove the screw securing the cover over the electrical connections on the valve, then remove the cover and disconnect the wires, noting where

Page 17

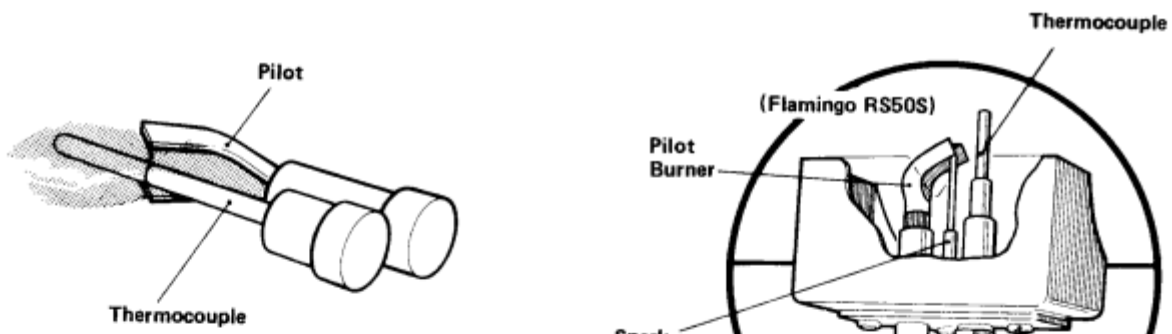

FIG. 13 THERMOCOUPLE - FLAME IMPINGEMENT

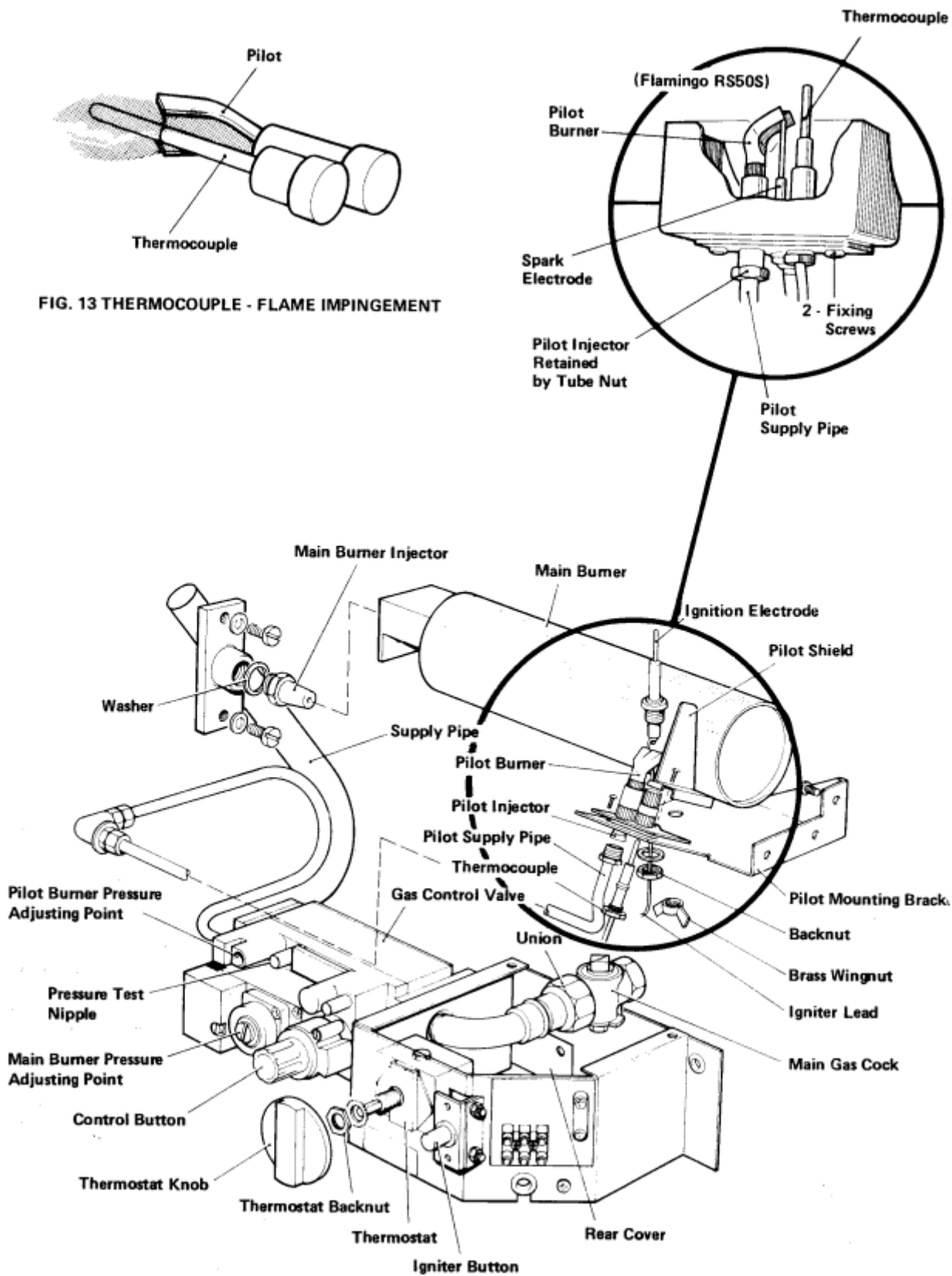

FIG. 14 EXPLODED VIEW OF FLAMINGO COMPONENTS

(Flamingo RS40 illustrated)

they were connected for reconnecting to the new valve.

5. Disconnect the pilot supply tube and the thermocouple connections from the valve.

6. Undo the lower screw securing cover at the rear and pivot downwards.
7. Break the union at the main gas cock, then unscrew the four screws securing the burner gas supply pipe to the outlet of the valve, remove the two hex, head screws securing the valve to the support bracket and lift away the valve.
8. Remove the inlet fittings from the old valve and fit them to the new one.
9. Replacement is the reverse of removal.
10. Test the boiler as described in [6, 'Final Adjustment'](#).

f. Boiler Thermostat

1. Turn off the boiler main gas cock.
2. Switch off the main electricity supply to the boiler.
3. Pull off the thermostat knob, then unscrew the captive screw securing the controls cover and slide the cover from the boiler.
4. Unscrew the two captive securing screws at the bottom of the casing and the single captive screw at the top, then withdraw the casing.
5. Withdraw the thermostat phial from its pocket in the heat exchanger.
6. Unscrew the backnut from around the spindle of the thermostat then remove the thermostat complete with its capillary. Note the route of the capillary so the new capillary can be similarly routed.
7. Disconnect the two electrical leads from the thermostat.
8. Replacement is the reverse of removal. Ensure that the thermostat phial is inserted to the full depth of its pocket.
9. Test the boiler as described in [6, 'Final Adjustment'](#).

g. Igniter Generator

1. Turn off the boiler main gas cock.
2. Switch off the main electrical supply to the boiler.
3. Pull off the thermostat knob, then unscrew the captive screw securing the controls cover to the boiler and pull off the cover.
4. Pull off the lead to the generator.
5. Unscrew the two securing screws and nuts and remove the generator.
6. Replacement is the reverse of removal.
7. Test the boiler as described in [6, 'Final Adjustment'](#).

h. Igniter Lead

1. Carry out operations (1) to (4) under ['B' Pilot Burner and Injector'](#).

2. Pull off the lead at the generator, then unclip the lead from the two clips beneath the combustion chamber.

3. Replacement is the reverse of removal.

CAUTION: When fitting the replacement lead, ensure that the end with the clear insulation is connected to the electrode and that with the black insulation connected to the generator.

4. Test the boiler as described in [6, 'Final Adjustment'](#)

BOILER DATA

Information concerning Boiler setting data can be found in [Table 1](#).

8. FAULT FINDING

As well as the fault finding chart given, reference should also be made to the wiring diagrams [Figure 6](#). For electrical faults check Figures [15](#), [16](#) and [17](#). Electrical procedures described are in accordance with the Instruction for Gas Multi-meter booklet.

CONDITION	POSSIBLE CAUSE	REMEDY
A. Pilot fails to light.	(1) No gas supply.	Check all cocks are open in the supply to the boiler.
	(2) Control button not pressed fully down.	Control button must be pressed fully down.
	(3) Blocked pilot filter	(a) Remove plastic electrical terminal cover from top of gas control valve by unscrewing the screw.
(b) Remove the four screws securing the solenoid valve to the top of the control valve.		
(c) Lift off the solenoid valve and the gasket beneath.		

Page 19

Service Section – Page 20

CONDITION	POSSIBLE CAUSE	REMEDY
		(d) Unscrew and remove the single screw securing the flat plate to the main valve body, then lift off the plate and the gasket beneath. (e) Lift out the filter and replace as necessary. (f) Re-assemble in the reverse order.
	4) Blocked pilot injector.	Remove and change the injector as described in Maintenance Instructions Section 7.b.

	5) Igniter generator not working	Check that the striker and plunger mechanism is operating correctly. If the operating mechanism is correct, proceed as follows:- (a) Disconnect the igniter lead from the generator, then place the stripped end of a suitable piece of insulated wire in the generator; hold the other end of the wire close to the boiler waterway, then operate the generator and check if a spark is made. If no spark appears, replace the generator. If a spark is made but it does not spark at electrode: replace electrode.
	(6) Electrode or lead damaged.	(a) Replace electrode or lead as detailed in Maintenance Instructions, Section 7.c or 7.h.
B. Main burner fails to light and pilot is extinguished when pressure on the button is released,	(1) Control button not held down long enough.	Control button must be fully pressed down for 20 seconds before main valve can be energised.
	(2) Loose thermocouple connection into control valve,	Tighten thermocouple union nut finger tight plus ¼ turn only. Ensure connection is clean and dry. TOO MUCH PRESSURE MAY DAMAGE INSULATION AND CAUSE FAILURE.
	(3) Pilot rate too low.	Adjust the pilot flame, see Section 6 .
	(4) Partially blocked pilot filter or pilot injector.	As item A(3) and A(4).
	(5) Failure of thermocouple, power unit or latching mechanism	After pilot has been on for 20 seconds, release control button. If pilot light goes out:- (a) Check F.F.D. and thermocouple using procedure given in Fig. 15 . (b) If thermocouple has failed, replace as described in Maintenance Instructions, Section 7.d.
C. Main burner fails to light, pilot burning.	(1) Boiler thermostat set to 'off' or low setting	Note setting of thermostat dial and check temperature of flow pipe.
	(2) Additional controls not calling for heat	Check programmer or clock is 'ON' and that room thermostat or other distant control is not closed down. Carry out preliminary electrical system checks.

	(3) Honeywell Control solenoid valve failed.	Check solenoid using procedure given in Figure 16 . If solenoid valve has failed; replace as described in A(3).
--	--	---

Page 20

Service Section – Page 21

CONDITION	POSSIBLE CAUSE	REMEDY
	(4) Thermostat out of calibration or faulty	Check thermostat using procedure given in Figure 17 . If faulty, replace thermostat as detailed in Maintenance Instructions, Section 7 .f.
	(5) Blocked main burner injector	Clean or replace injection as detailed in Maintenance Instructions Section 7.a.
D. Main burner fails to shut down when water reaches predetermined temperature	(1) Thermostat out of calibration or faulty.	Remedy as in item C(4).
	(2) Dirt on valve seat of Honeywell control.	<p>Clean the valve seat as follows:-</p> <p>(a) Remove the solenoid valve and the plate beneath as described in A(3).</p> <p>(b) Clean the valve seat and the valve chamber.</p> <p>(C) Re-assemble in the reverse order.</p>

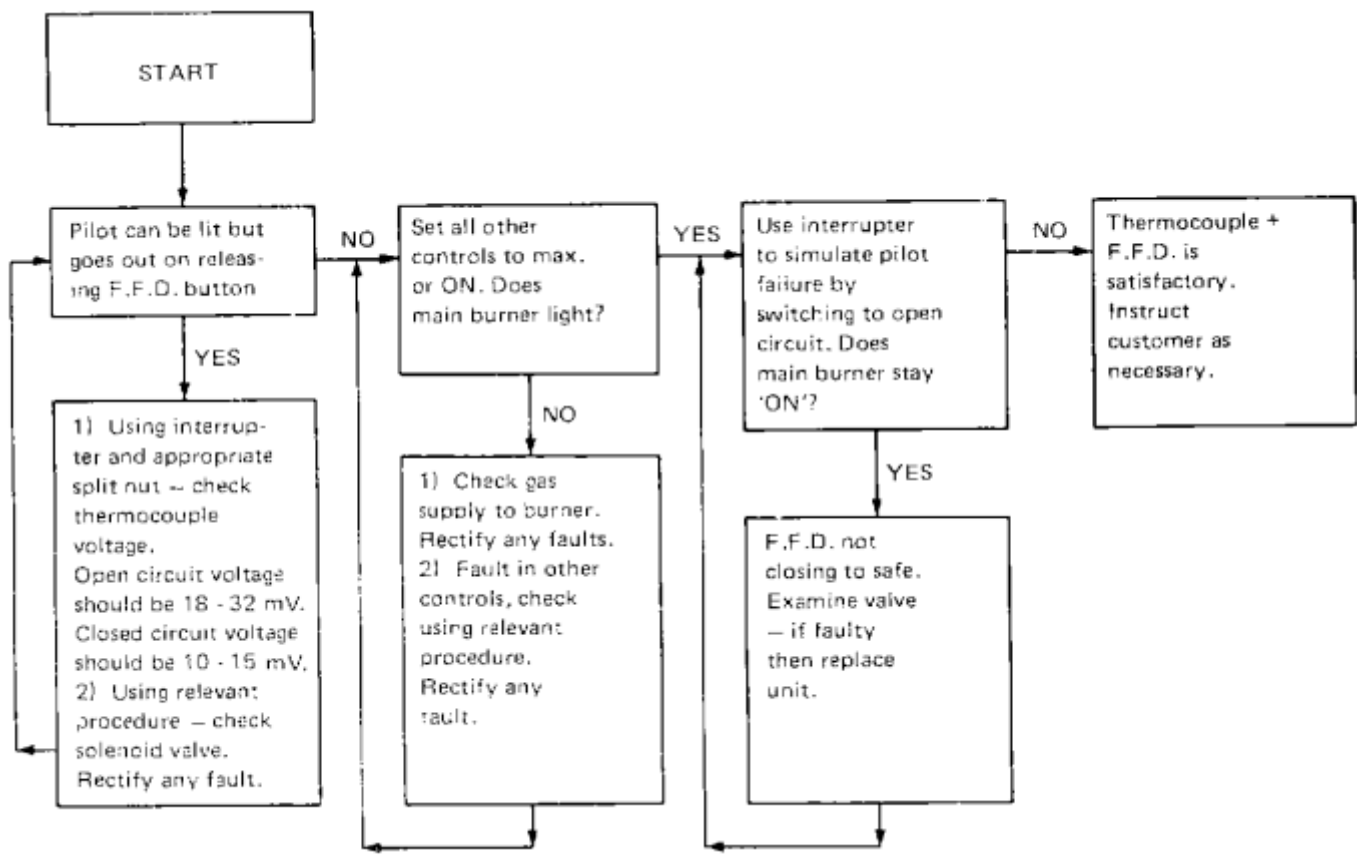

FIG. 15 F.F.D. AND THERMOCOUPLE

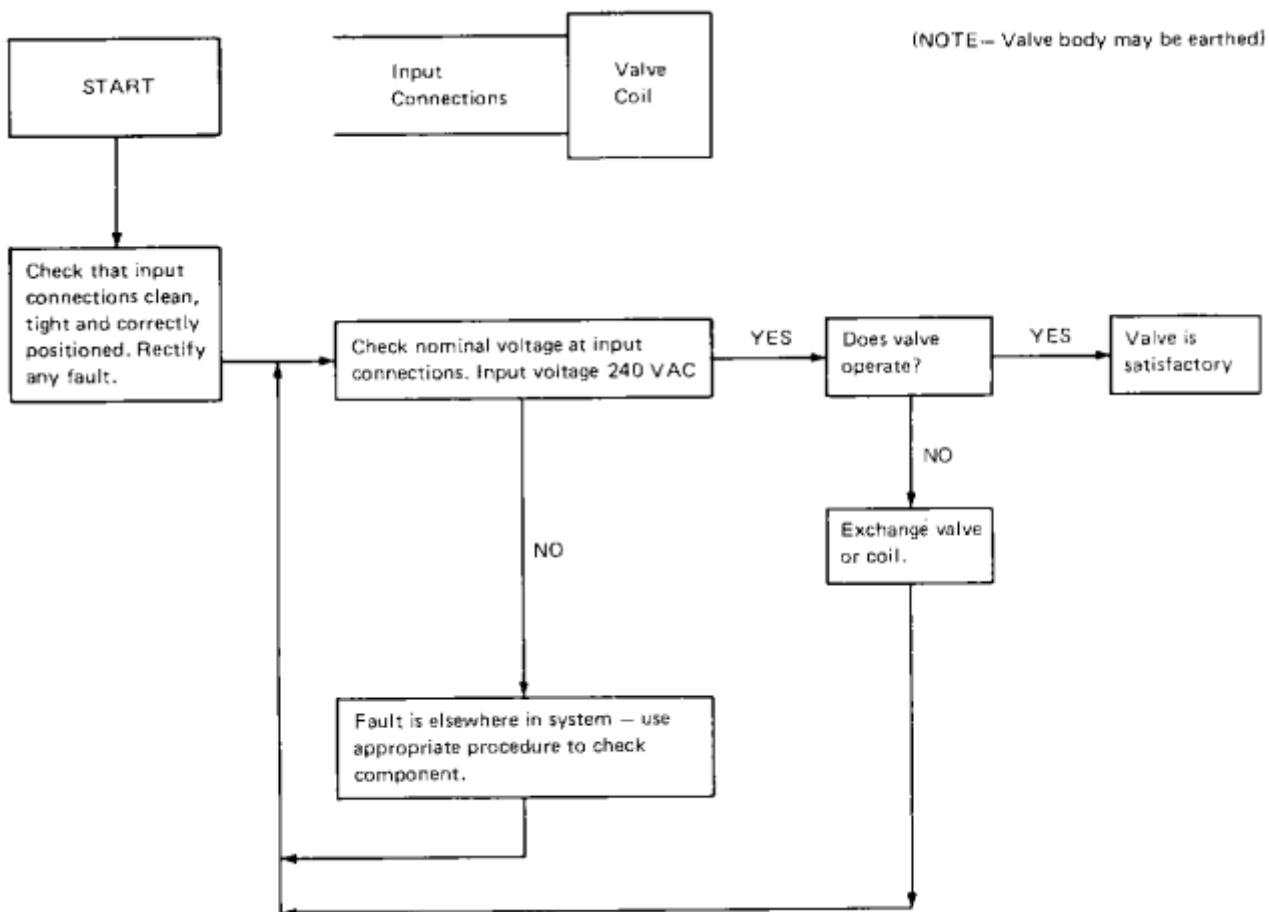

FIG. 16 SOLENOID VALVE

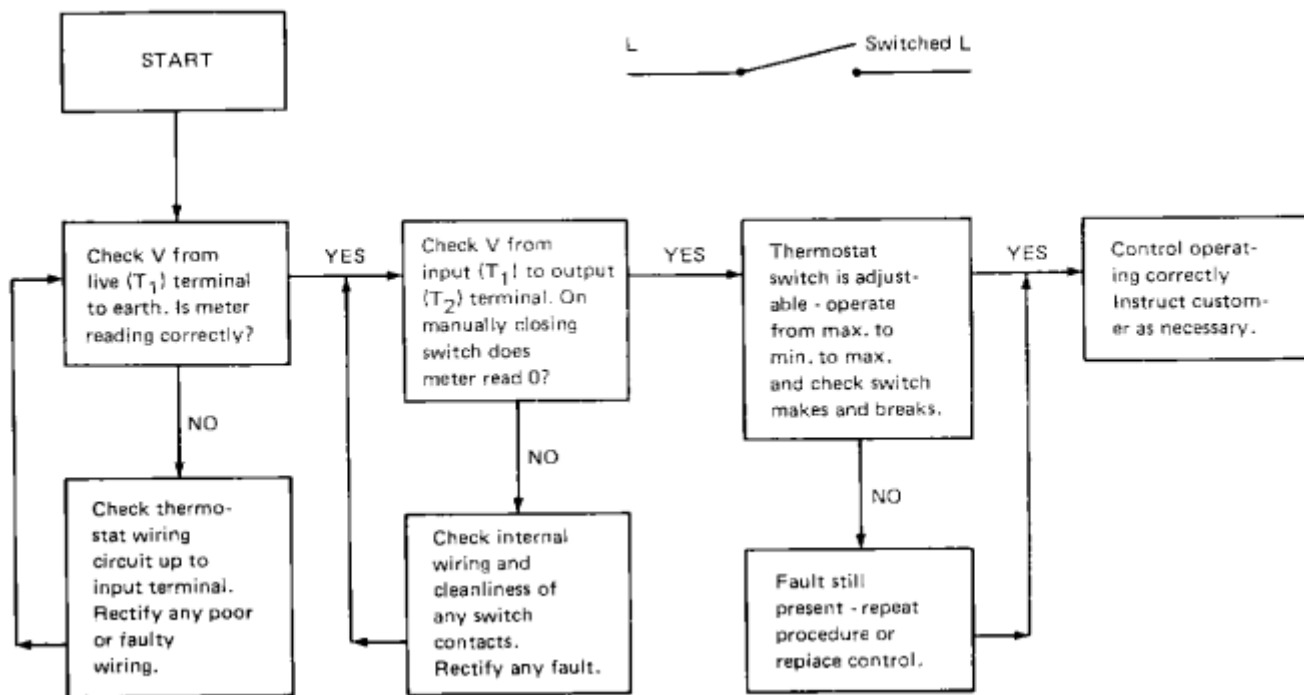

FIG. 17 THERMOSTAT

Service Section – Page 23

R.S.50S KEY NO.	R.S.40 KEY NO.	DESCRIPTION	POTTERTON PART NO.	BRITISH GAS PART NO.
93		Pilot Burner Honeywell Q359 A	402834	358 282
	97	Pilot Burner Honeywell Q314 A	402490	391 158
94		Pilot Injector	410917	358 232
	98	Pilot Injector BCR 18	410209	390 794
71	75	Solenoid Operator	904750	396 693
70	74	Main Gas Valve	402803	393 659
90	103	Thermocouple Honeywell Q309A	402254	390 038
55	58	Thermostat Ranco C26	200996	382 291
107	114	Thermostat Knob	200277	357 634
85	90	Main Burner Injector Orifice 3.35mm dia.	410909	
56	59	Iqnitier Generator Vernitron	407623	387 951
92		Ignition Electrode	407635	
	101	Ignition Electrode	407625	387 999
91	104	Electrode Lead	407635	393 203

