

# OMYSON

## Installation and Servicing Instructions

### Orion 75Si wall mounted gas boiler

G.C.Appliance No. 41 494 21

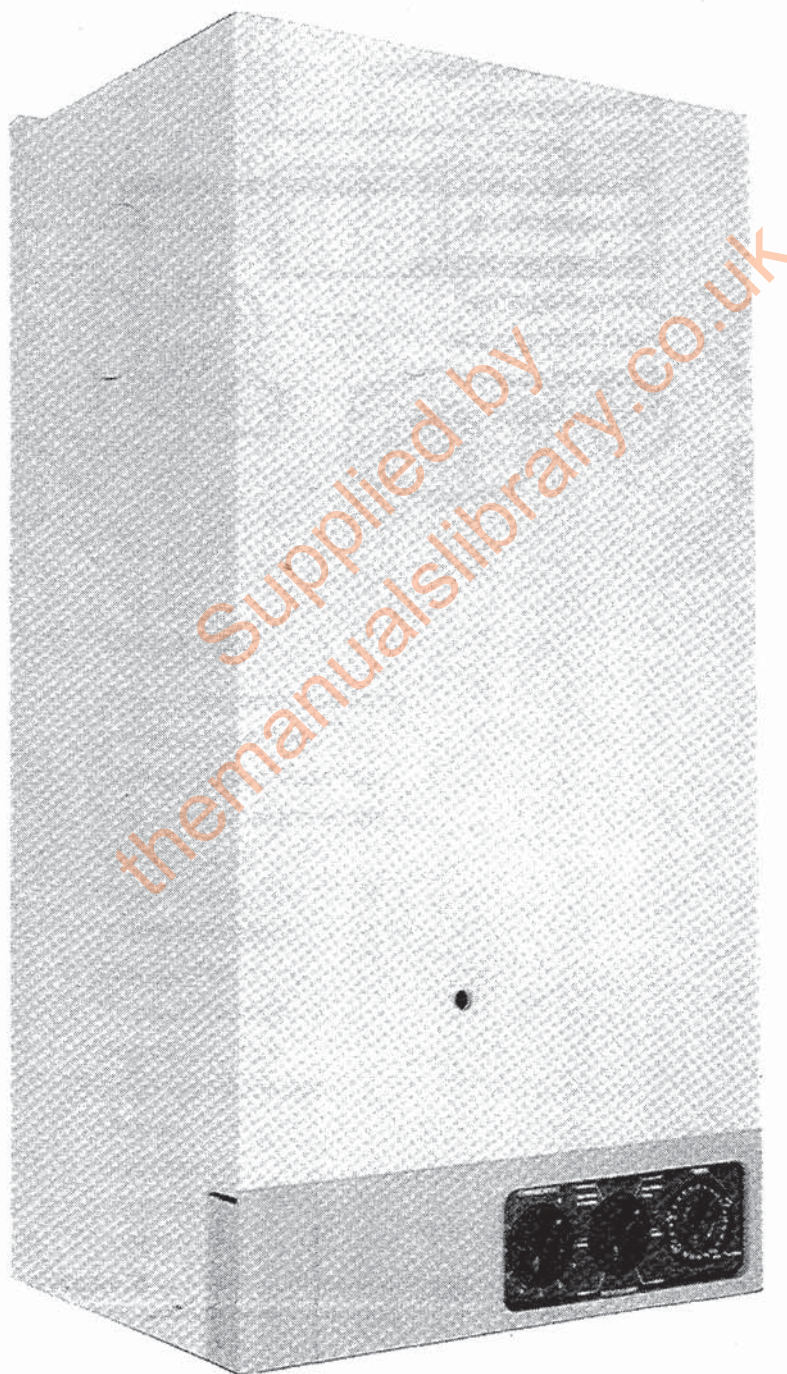

Shown with Orion  
Programmer kit.

**Read these instructions thoroughly before working on the boiler.  
For use with Natural Gas only. (Leave these instructions adjacent to the gas meter).**

## LIST OF CONTENTS

<b>Section</b>	<b>Subject</b>	<b>Page</b>
1	Introduction	3
2	Technical data	3
3	General requirements	3
4	Delivery	4
5	Gas supply	4
6	Electricity supply	4
7	Air supply	4
8	Flue system	4
9	Boiler location	4
10	Water system schematics and water connections	5
11	Sealed system requirements	6
12	Installation procedure	7
13	Complete the installation	11
14	Commissioning	11
15	Boiler controls	12
16	Final assembly and handing over the installation	12
17	Annual servicing	13
18	Replacement of parts	14
19	Wiring diagrams	18
20	Fault finding guide	21
21	Exploded view	22
22	Short list spare parts	23

## 1. INTRODUCTION

This fanned draught room-sealed wall mounted boiler is for use on natural gas only, and is suitable for rear or side exit flue. The Orion 75Si is range rated at outputs of 17.5 and 21.9 kW (60 000 and 75 000 Btu/h) and is factory set to the maximum output. The boiler is designed for use on open vented or sealed systems with an indirect hot water cylinder. THE BOILER MUST NOT BE CONNECTED TO A DIRECT CYLINDER.

## 2. TECHNICAL DATA

For serial No. see left hand side of control box.

Boiler	Orion 75Si	
Burner type	Furigas 175-500-025 or Bray AB24052	
Burner injector	Furigas 400	
Pilot injector	Honeywell 4500-4108-005 marked 56/42A	
Pilot flame	35 to 40 mm	
Spark gap	3.0 to 4.0 mm	
Ignition	Intermittent pilot	
Weight (empty)	72.0 kg (158 ¾ lb)	
Lifting weight (installing)	59.3 kg (130 ¾ lb)	
Water content	8.0 litre (1.75 gal)	
Maximum static head	30.5 m (100 ft)	
Minimum static head	150 mm (6 in) from top of white case	
Head loss	Gravity systems: 1.02 m (40 in) Fully pumped systems: 0.46 m (18 in)	
Maximum flow temperature	82°C	
Recommended flow through boiler	28 l/min (6.2 gpm)	
Design water temperature rise	11°C	
Height	790 mm (31 in)	
Width	400 mm (15 ¾ in)	
Depth	310 mm (12 ¼ in)	
Clearance required for servicing	Top	150 mm (6 in)
	Bottom	150 mm (6 in)
	Front	450 mm (18 in)
	Sides	15 mm ( ¾ in)
Flue terminal size	100 mm dia x 65 mm deep (4 in dia x 2½ in deep)	
Water connections	Compression fittings to accept 28 mm copper tubing to BS2871	
Gas connection	Rp½	

### NOMINAL BOILER RATINGS

Boiler	Output		Input		Burner setting pressure	
	kW	Btu/h	kW	Btu/h	mbar	in wg
Orion 75Si	17.5	60 000	23.8	81 600	10.3	4.1
	21.9	75 000	29.3	100 000	15.0	6.0

## 3. GENERAL REQUIREMENTS

The boiler must be installed in accordance with: The Gas Safety (Installation and Use) Regulations 1984 and the current issue of the Building Regulations, Building Standards (Scotland) Regulations, Local Building Regulations, Model and local Water Undertaking Byelaws and IEE Wiring Regulations.

Detailed recommendations are stated in the following British Standards: BS5440:1:1978, BS5440:2:1976, BS5449:1:1977, BS5546:1979, BS6798:1987 and BS6891:1988.

**Note - Gas Safety Regulations 1984:** It is the law that all gas appliances are installed by competent persons, in accordance with the above regulations. Failure to install appliances correctly could lead to prosecution. It is in your own interest, and that of safety to ensure that the law is complied with.

#### 4. DELIVERY

The unit is delivered in two packages (1) the cased boiler and (2) the flue/terminal assembly type A, B, C, D or E as required. In addition a 965 mm (38 in) flue extension is available. Under no circumstances should more than one extension kit be used. A plug-in programmer kit is available to fit inside the boiler casing. This programmer simplifies wiring and is suitable for use with all external control systems shown in the system wiring diagrams supplied with the boiler.

A telescopic pump housing kit is available, this is a case extension adjustable from 150 mm to 275 mm which allows the pump to be accommodated above the boiler where it is easily accessible.

A fit from the inside kit is available which allows the flue/terminal assembly to be fitted from inside the building.

#### 5. GAS SUPPLY

The Orion 75Si requires 2.8 m<sup>3</sup>/h (99 ft<sup>3</sup>/h) of natural gas. The meter and supply pipes must be capable of delivering this quantity of gas in addition to the demand from any other appliances in the house.

The complete installation must be tested for gas soundness and purged as described in BS6891.

#### 6. ELECTRICITY SUPPLY

240V ~ 50 Hz via a fused double pole switch with a contact separation of at least 3 mm in both poles or preferably a fused 3 pin plug and shuttered socket outlet (both complying with the requirements of BS1363) adjacent to the boiler.

Fuse the supply at 3 A. The minimum requirement for the power supply cable is that it should be a PVC sheathed flexible cord at least 0.75 mm<sup>2</sup> (24 x 0.2 mm) (code designation HO55 VV-F or HO5 VVH2-F) as specified in table 16 of BS6500:1984.

All wiring external to the boiler shall comply with the latest IEE Wiring Regulations and any local regulations which apply.

**The appliance must be earthed.**

In the event of an electrical fault after installation of the appliance, preliminary electrical system checks must be carried out as described in the British Gas multimeter instruction book.

#### 7. AIR SUPPLY

The room in which the boiler is installed does not require a purpose provided air vent.

If the boiler is installed in a cupboard or compartment, permanent air vents are required in the cupboard or compartment, one at high level and one at low level, either direct to the outside air or to a room. Both high and low level air vents must communicate with the same room or must be on the same wall to the outside air. For the Orion 75Si the high and low level vent must each have a free area of 264 cm<sup>2</sup> (40 in<sup>2</sup>). The free area of each vent may be halved if the ventilation is provided directly from outside.

If the boiler is installed in a cupboard or compartment with a door, allow at least 100mm clearance between the front of the boiler and the door for air movement.

#### 8. FLUE SYSTEM

Five telescopic flue/terminal assemblies are available and a fixed length, 965 mm (38 in), extension kit.

The flue lengths are:

Size A: 123 - 175 mm (4¾ - 7 in)

Size B: 171 - 275 mm (6¾ - 10¾ in)

Size C: 274 - 478 mm (10¾ - 18¾ in)

Size D: 363 - 652 mm (14¼ - 25¾ in)

Size E: 582 - 1092 mm (23 - 43 in)

Unless otherwise specified the C size flue/terminal will be supplied with the boiler.

The following method should be used to determine the required flue/terminal assembly.

Rear flue  $A = C + 19 \text{ mm (0.75 in)}$

Side flue  $A = B = C = 35 \text{ mm (1.375 in)}$

Where A = required flue length, B = inside wall to side of boiler and C = finished wall thickness.

If A is greater than 1092 mm (43 in) one extension kit may be used.

**Note:** The maximum allowable flue length is 2057 mm (81 in).

#### 9. BOILER LOCATION

The boiler is not suitable for external installation.

The boiler must be mounted on a flat wall which is sufficiently robust to take the weight of the boiler.

The boiler is suitable for installation to a combustible wall e.g. wood cladding, provided that the air/flue tube assembly is not closer than 25 mm (1 in) to combustible material. A metal sleeve should be installed to surround the air/flue tube assembly to provide a 25 mm (1 in) annular space. Further guidance is given in BS5440:1:1978, sub-clause 20.1.

If the boiler is installed in a timber framed building it should be fitted in accordance with the British Gas publication - "Guide for Gas Installation in Timber Framed Housing" reference DM2. If in doubt advice must be sought from the local region of British Gas or from Myson Heating.

The boiler may be installed in any room, although particular attention is drawn to the requirements of the current IEE Wiring Regulations and, in Scotland, the electrical provisions of the Building Standards applicable in Scotland, with respect to the installation of the boiler in a room containing a bath or shower.

Where a room-sealed appliance is installed in a room containing a bath or shower any electrical switch or appliance control, utilising mains electricity should be so situated that it cannot be touched by a person using the bath or shower.

Where the installation of the boiler will be in an unusual position, special procedures may be necessary and BS5546 and BS6798 give detailed guidance on this aspect.

A cupboard or compartment used to enclose the boiler must be designed and constructed specifically for this purpose. An existing cupboard or compartment may be used provided that it is modified for the purpose. Details of essential features of cupboard/compartment design including airing cupboard installations are given in BS5546 and BS6798 and should be complied with.

When using side exit flue the air/flue tube may be 'hidden' by boxing in if required. See BS5440:1:1978, sub-clause 20.1 for details.

If the boiler is to be installed in a run of kitchen units it is recommended that the boiler is fitted first or the adjacent units removed. The boiler must be installed so that the flue terminal is exposed to the external air. It is important that the position of the terminal allows the free passage of air across it at all times.

The minimum acceptable spacings from the terminal to obstructions, corners and ventilation openings are specified in the following table:

Terminal position	Minimum spacing
Directly below an openable window, air vent or any other ventilation opening	300 mm (12 in)
Below gutters, soil pipes or drain pipes	75 mm (3 in) *
Below eaves or a balcony	200 mm (8 in) *
Above adjacent ground or balcony level	300 mm (12 in) **
From vertical soil pipes or drain pipes	75 mm (3 in)
From internal or external corners	25 mm (1 in)
From a surface facing the terminal	600 mm (24 in)
From a terminal facing the terminal	1200 mm (48 in)
Vertically from a terminal on the same wall	1500 mm (60 in)
Horizontally from a terminal on the same wall	300 mm (12 in)
Adjacent to an opening window	150 mm (6 in)
From an opening in a car port i.e. door or window into the house	1200 mm (48 in)

\* If the terminal is fitted within 850 mm (34 in) of a plastic or painted gutter/pipe or 450 mm (18 in) of painted eaves, an aluminium shield of at least 750 mm (30 in) in length should be fitted to the underside of the gutter/pipe or painted surface.

\*\* If the terminal is fitted less than 2 m (6.6 ft) above balcony, above ground or above a flat roof to which people have access then a suitable terminal guard must be provided and fitted.

A type K1 protective guard is available from Tower Flue Components Ltd. at Vale Rise, Tonbridge, Kent TN9 1TB. Tel: 0732 351555.

## 10. WATER SYSTEM SCHEMATICS AND WATER CONNECTIONS

It is recommended that the outermost water connections are made first, this will ensure that access to all the fittings is available if the boiler is fitted in a corner or recess. **NOTE:** All the flow and return connections on top of the boiler have been temporarily sealed with plastic plugs. Remove **ALL FOUR** plugs before connecting any pipework

Compression fittings are supplied loose with the boiler to accept 28 mm copper tubing to BS2871.

Always ensure that the pump has sufficient static head. Check the pump manufacturers minimum head.

Ensure that the pump is accessible for servicing. Isolating valves must be positioned as close to the pump as possible.

Fit one or more draining taps (BS2879) to enable the water system to be fully drained.

### a. Gravity domestic hot water with pumped heating

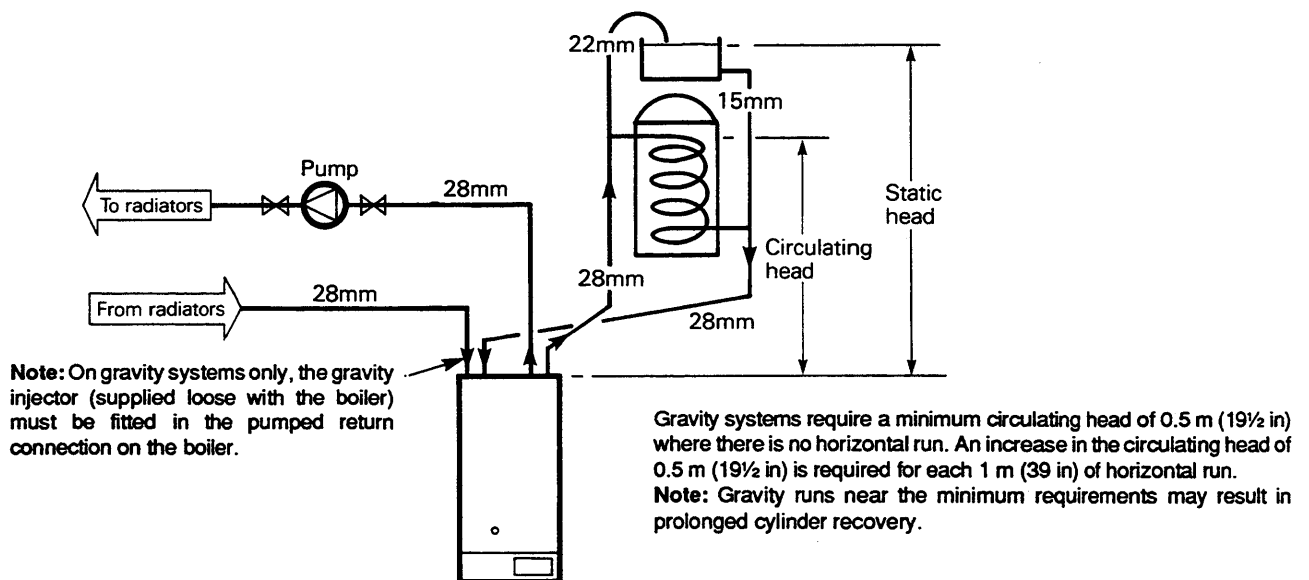

**b. Fully pumped system**

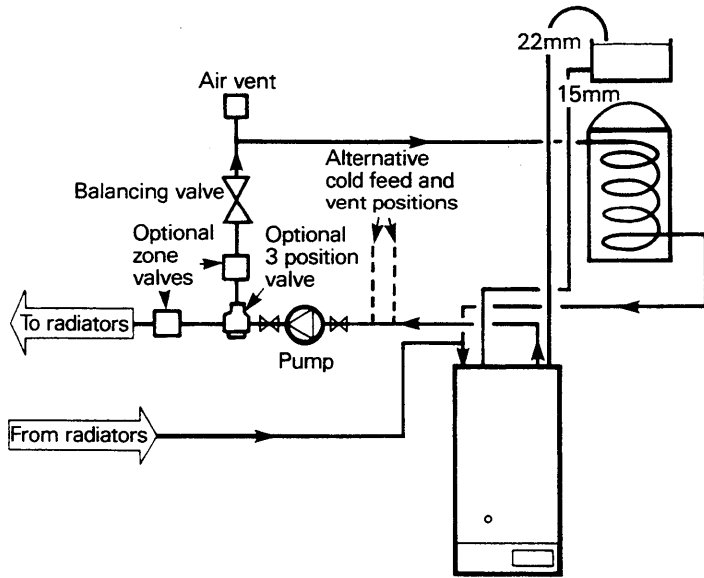

Two blanking caps, to be used with the 28 mm nuts and olives, are supplied to blank off two of the 28 mm connections if the feed and vent are not connected directly to the boiler.

If the cold feed and vent connections are on the flow pipe, they should be as close to the boiler as practicable and no more than 150 mm apart.

For use with thermostatic radiator valves, zone valves or 3 position valve.

**c. Low head system**

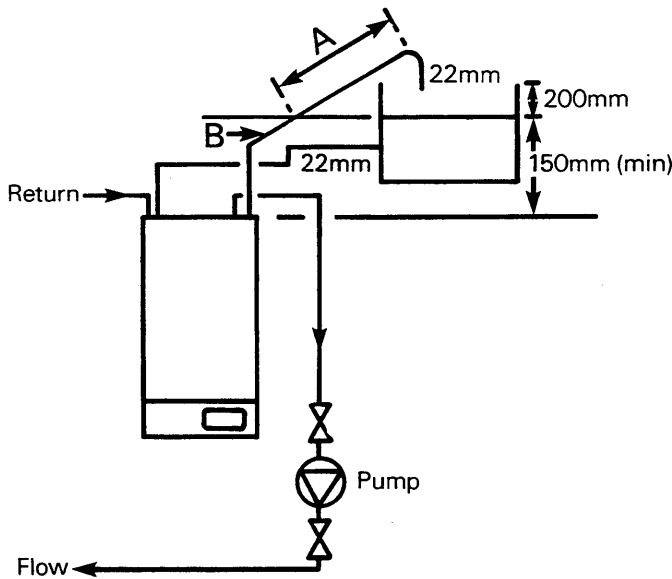

A - length of dry vent  
B - length of water filled vent

HEATING LOAD Btu/h	VENT LENGTH	
	A (mm)	B (mm)
75 000	630	460
60 000	520	400

**Note:** The cold feed and vent must be connected directly to the boiler as shown.

**d. Water connections**

All dimensions in mm

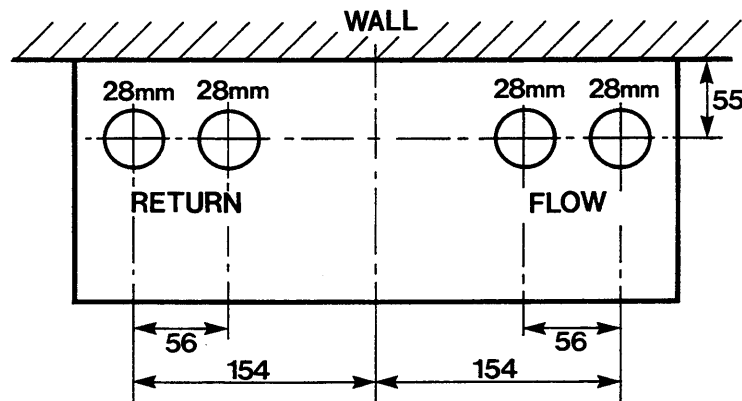

Top view of boiler showing water connections

**11. SEALED SYSTEM REQUIREMENTS**

- The installation must comply with the requirements of BS5449:1 and BS6798. Maximum water temperature is  $82^{\circ}\text{C} \pm 3^{\circ}\text{C}$ .
- A safety valve set to operate at 3 bar (45 lbf/in<sup>2</sup>) shall be fitted in the flow pipe close to the boiler. There must not be any valves between the safety valve and the boiler. This valve should be positioned on a discharge pipe fitted to prevent any discharge creating a hazard to occupants or cause damage to electrical components and wiring.
- A pressure gauge covering at least the range 0 to 4 bar (0 to 60 lbf/in<sup>2</sup>) shall be fitted in the system.

- d. A diaphragm type expansion vessel, to BS4814, shall be connected at a point close to the inlet side of the pump. The vessel must be chosen to suit the volume of water in the system and the charge pressure must not be less than the static head at the point of connection. Further details can be obtained from "Material and Installation Specification for Domestic Central Heating and Hot Water" published by British Gas.

Sizing table:

Air or Nitrogen charge pressure (bar)	0.5		1.0	
Pre-pressurisation pressure (bar)	None	1.0	None	1.5
Expansion vessel volume (litres)	A x 0.07	A x 0.120	A x 0.088	A x 0.160

A = System volume (litres)

- e. The hot water cylinder shall either be the indirect coil type or a cylinder fitted with an immersion calorifier.
- f. Water lost from the system shall be replaced from a make-up vessel, and non return valve, mounted higher than the top of the system on the return side of the cylinder or radiators. Where access to a make-up vessel would be difficult, make-up can be provided by pre-pressurisation of the system.
- g. The system may be filled from the mains via a temporary hose connection from a draw-off tap supplied from the service pipe under mains pressure, provided that this procedure is acceptable to the local water authority. The following fittings should form a permanent part of the system and fitted in the order stated:
- a stop valve complying with the requirements of BS1010:2,
  - a test cock,
  - an anti-vacuum valve of a type approved by the National Water Council and
  - a non-return valve of an approved type.
- h. Fill the system until the pressure gauge registers 1.5 bar (22 lbf/in<sup>2</sup>). Examine for leaks and rectify where necessary.
- i. Refer to the commissioning instructions, light the boiler and allow the system to reach its maximum working temperature. Examine for leaks then turn off the boiler. Drain the system while it is still hot. Refill, vent and adjust the cold fill pressure to the required value.

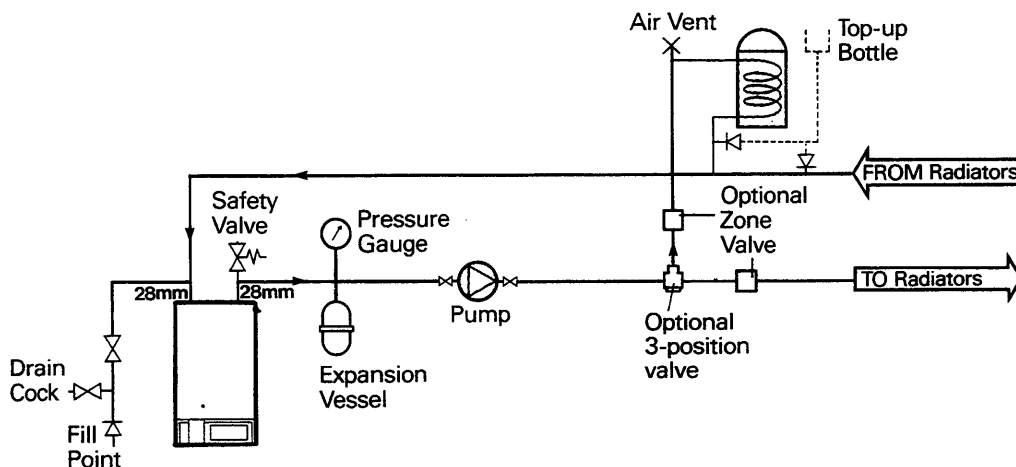

## 12. INSTALLATION PROCEDURE

**Note: For REAR FLUE applications refer to frames 1 to 12.  
For SIDE FLUE applications refer to frames 1 to 4 and 13 to 19.**

### 1 UNPACK THE BOILER

Carefully unpack the boiler. Do not discard the packing until all the items are found.

- Flue tube sleeve (supplied loose behind bottom cover)
- M6 boiler fixing screws (4 off)
- 28mm blanking caps (2 off)
- Wall mounting plate (1 off)
- Flue gasket
- Lifting handles (2 off)
- 28mm nuts and olives (4 off each)
- Gravity injector (1 off)
- M6 large washers (4 off)

**Find these parts in the pack.**

### 2 REMOVE THE BOILER CASE

Remove the bottom cover by pulling it forwards to disengage the fixing pins. Remove the two screws securing the case bottom panel to the side panels and slide out the bottom panel. Unscrew the three case front panel fixing screws (two at the top and one at the bottom) and lift off the front panel. Remove the two screws securing the side panel at the top and remove by sliding the panel towards the top of the boiler and lifting it off. Repeat for the other side. Keep all the panels in a safe place so as not to damage them before refitting. Discard all the polystyrene packing pieces.

**REMOVE AND KEEP THE FLUE TUBE SLEEVE SUPPLIED LOOSE BEHIND THE BOTTOM COVER.**

### 3 BOILER DIMENSIONS AND GAS CONNECTION

All dimensions in mm

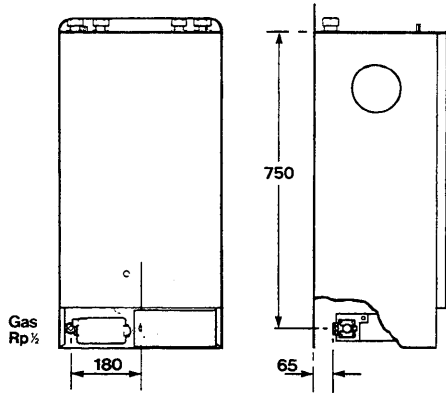

Overall cased dimensions.

Height: 790 mm  
Width: 400 mm  
Depth: 310 mm

Clearances required for servicing.

Top: 150 mm  
Bottom: 150 mm  
Front: 450 mm  
Side: 15 mm

### 4 MINIMUM BOILER CLEARANCES

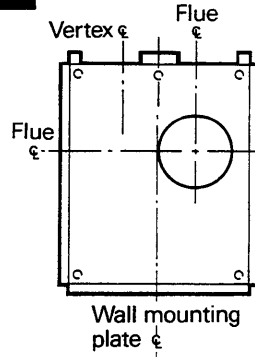

To determine the position of the boiler measure the following distances from the raised edges of the wall mounting plate. These distances include the required minimum clearances.

Top: 146 mm  
Bottom: 579 mm  
Side: See note below

**Note:** If the boiler is installed adjacent to an internal corner, with side exit flue the minimum side clearance is 130 mm from the raised edge of the wall mounting plate. If the boiler is installed using the internal flue fixing kit, and side exit flue the minimum side clearance is 97 mm from the raised edge of the wall mounting plate. Additional clearances for installation will be required, these are to be left to the discretion of the installer.

### 5 PREPARE THE WALL

All dimensions in mm

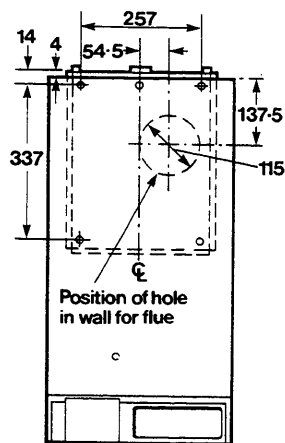

1. Decide upon the position of the boiler ensuring that the flue terminal position will meet the requirements given on page 5.
2. Remove and discard the four screws, sealing plate and gasket from the wall mounting plate.
3. Using the wall mounting plate as a template mark the position of the hole for the flue and the five fixing holes for the wall mounting plate. Ensure the plate is level and the right way up.
4. Cut the 115 mm (4½ in) dia. hole in the wall and drill and plug the fixing holes to accept 2½" lg. No. 12 woodscrews.
5. Make a note of the finished wall thickness, this is very important and is required for frame 7 when adjusting the flue/terminal assembly.

6. Secure the wall mounting plate in position with five 2½" lg. No. 12 woodscrews (not supplied). Ensure it is level, the right way up and that the hole for the flue is centralised over the hole cut in the wall.

### 6 UNPACK THE FLUE TERMINAL ASSEMBLY

Carefully unpack the flue/terminal assembly. Do not discard the packing until all the items are found.

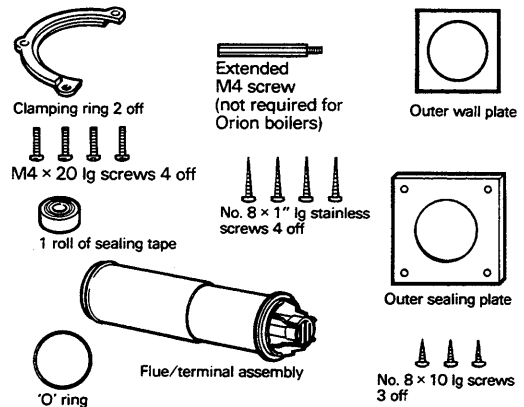

Find these parts in the pack

### 7 ADJUST THE LENGTH OF THE FLUE / TERMINAL ASSEMBLY

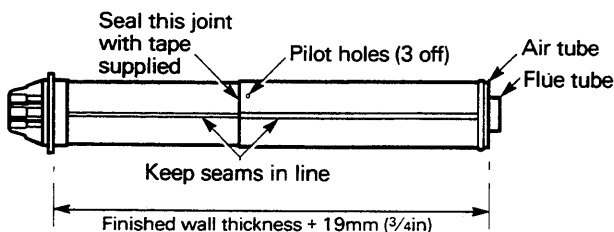

1. Using the measurements noted in frame 5 adjust the length of the flue/terminal assembly so that it is 19 mm (¾ in) + finished wall thickness, from the back of the terminal flange to the end of the OUTER air tube as shown.  
**Note:** Ensure that the seams in the outer air tubes are in line.
2. Drill through the three pilot holes, shown above, with a 2.8 mm drill and secure the two tubes together using the three No.8 x 10 lg screws supplied with the flue/terminal assembly.  
**Note:** When drilling through the outer air tube take care not to damage the inner flue tube with the drill.
3. Seal the centre joint with the tape supplied.

### 8 FIT THE FLUE / TERMINAL ASSEMBLY

**Note:** If the wall is to be made good up to the terminal the outer wall plate need not be used.

1. Fit the outer wall plate over the flue/terminal assembly.

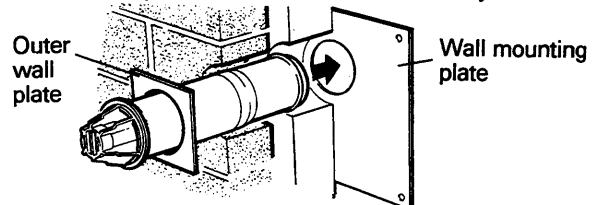

2. From outside the building insert the flue/terminal assembly into the wall. Ensure that the slots in the end of the terminal are vertical.
3. From inside the building fit the flue gasket, supplied with the boiler, in position over the outer air tube and behind the flared section. Fit the 'O' ring, supplied with the flue, over the outer air tube and in front of the flared section. See frame 9.
4. Secure the flue/terminal assembly to the wall mounting plate using the two halves of the clamping ring as shown in frame 9. Ensure that the recessed side of the clamping ring is against the flared section of the air tube.
5. Secure with four M4 screws supplied, tightening to seal the flue assembly to the mounting plate.



**9** Flue / Terminal Assembly - *continued*

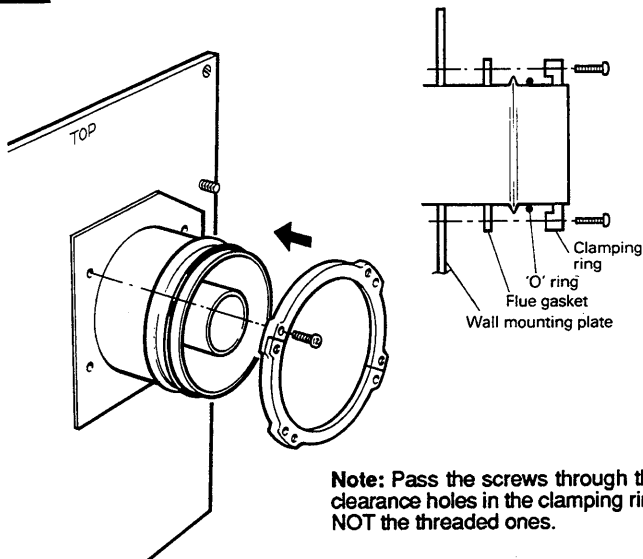

**Note:** Pass the screws through the clearance holes in the clamping ring NOT the threaded ones.

**10** PREPARE THE BOILER

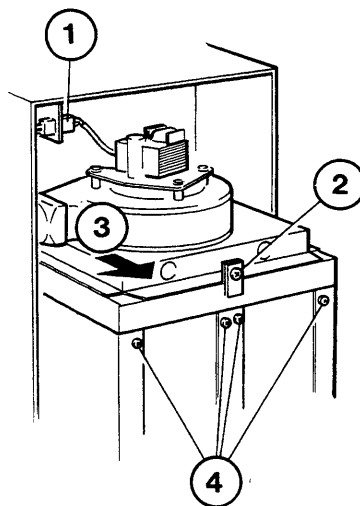

1. Disconnect the 3-way plug and socket for the fan leads.
2. Remove the screw securing the front of the flue hood to the heat exchanger top frame.
3. Slide out the flue hood and fan assembly.
4. Remove the four screws indicated.
5. Fit the two lifting handles supplied, to the front of the heat exchanger using the screws previously removed.

**11** SECURE THE BOILER TO THE WALL PLATE

**Note:** Due to the weight of the boiler it is recommended that two people lift it onto the wall mounting plate.

1. Using the lifting handles and the base of the heat exchanger as lifting points position the boiler over the wall mounting plate.
2. The boiler has two brackets on the back of the chassis at the top, these should be located on top of the wall mounting plate to take the weight of the boiler.
3. Secure the boiler to the mounting plate using the four large washers and M6 screws supplied with the boiler. Before the screws are tightened ensure that the line marked on the wall mounting plate and the notch at the top of the circular opening in the back of the chassis are aligned.
4. Remove and discard the lifting handles and replace the screws.

**NOTE:** ALL FOUR FIXINGS MUST BE USED.

**12** REASSEMBLE THE BOILER

1. Fit the flue tube sleeve (supplied loose behind the bottom cover) over the fan outlet and push fully home.
2. Refit the flue hood and fan assembly by sliding the flue hood under the returns on the sides of the heat exchanger top frame. Take care to ensure that the pressure switch sensing pipe is engaged in its guide bracket on the rear of the flue hood.
3. Check that the flue tube sleeve fits over the inner flue tube and push the flue hood fully home.
4. Secure the flue hood to the heat exchanger top frame using the one screw at the front, previously removed.
5. Reconnect the 3-way plug and socket for the fan leads.
6. Proceed to frame 19.

**13** PREPARE THE WALL AND FIT THE BOILER

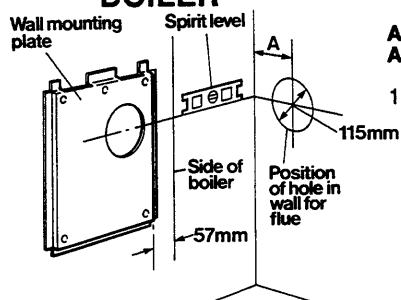

A = 215 mm for R.H. flue  
A = 167 mm for L.H. flue

1. Decide upon the position of the boiler. Note that the maximum distance (using the longest flue/terminal assembly and one flue extension) from the side of the white case to the OUTSIDE wall is 2012 mm (79.6 in).
2. Using the wall mounting plate as a template mark the position of the five fixing holes, side of the boiler (see frame 4) and the horizontal centre line of the flue. Ensure that the plate is level and the right way up.
3. Continue the horizontal flue centre line across the wall until it reaches the side wall and continue it around onto the side wall. Ensure these lines are level. If left hand flue is to be used the flue centre line is 167 mm (6½ in) from the rear wall. If right hand flue is used the flue centre line is 215 mm (8½ in) from the rear wall.
4. Mark the position of the flue centre line on the side wall and check that the terminal position will meet the requirements given on page 5.

**14** Fit the Boiler - *continued*

5. Drill and plug the five wall mounting plate fixing holes to accept 2½" lg No. 12 woodscrews.
6. Cut the 115 mm (4½ in) dia. hole in the side wall for the flue/terminal assembly in the position previously marked, ensuring it is horizontal.
7. Make a note of the finished wall thickness and the distance from the side wall to the side of the white case. The side of the boiler white case is 57 mm from the raised section of the wall mounting plate as shown in frame 13. These measurements are very important and are required in frame 15 when adjusting the flue/terminal assembly.
8. Secure the wall mounting plate in position with five 2½" lg No. 12 woodscrews (not supplied). Ensure it is level and the right way up.
9. Prepare the boiler and secure to the wall as described in frames 10 and 11.
10. Select the side panel appropriate to LH or RH exit flue, remove the edge clips and push out the round infill panel.
11. Secure the side panel to the chassis top using the two screws previously removed.
12. Unpack the flue/terminal assembly as described in frame 6.

15

## ADJUST THE LENGTH OF THE FLUE / TERMINAL ASSEMBLY

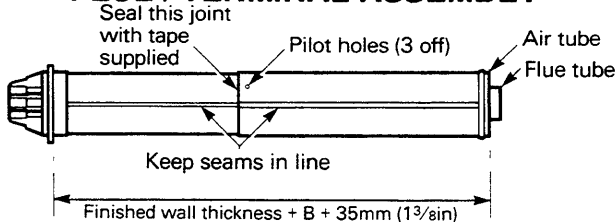

(B is the distance between the wall and the side of the boiler white case)

- Using the measurements noted in frame 14, adjust the length of the flue/terminal assembly so that it is 35 mm (1.4 in) + finished wall thickness + distance between the wall and the side of the boiler white case from the back of the terminal flange to the end of the OUTER air tube as shown.  
**Note:** Ensure that the seams in the outer air tubes are in line.
- Drill through the three pilot holes shown above, with a 2.8 mm drill and secure the two tubes together using the three No. 8 x 10 lg screws supplied with the flue/terminal assembly.  
**Note:** When drilling through the outer air tube take care not to damage the inner flue tube with the drill.
- Seal the centre joint with the tape supplied.

16

## FLUE EXTENSION

The flue extension kit allows the standard flue/terminal assembly to be extended by 965 mm (38 in).

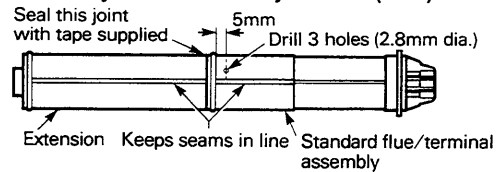

- If the flue extension kit is used, connect the plain end of the extension to the swaged end of the standard flue/terminal. Ensure that the inner flue tube of the standard flue/terminal fits **INSIDE** the inner flue tube of the extension and the outer air tube fits **OVER** the air tube of the extension. Push fully home.  
**Note:** Ensure that the seams in the outer air tubes are in line.
- Drill three equally spaced holes using a 2.8 mm drill in the position shown, through both the standard flue/terminal and the extension tube sleeve. Secure the two tubes together using three No. 8 x 10 lg screws supplied with the flue extension.  
**Note:** When drilling through the outer air tube take care not to damage the inner flue tube with the drill.
- Seal the joints with the tape supplied with the flue extension.
- Adjust the **OVERALL** length as described in frame 15. Secure and seal the joints.

17

## FIT THE FLUE / TERMINAL ASSEMBLY

- Remove and discard the four screws, sealing plate and gasket from the chassis side through which the flue is to exit.
- The flue is fitted in the same way as described in frames 8 and 9 but is secured to the chassis side from inside the fan compartment.

Ensure that the flue gasket has the edge with the corners removed towards the front of the boiler.

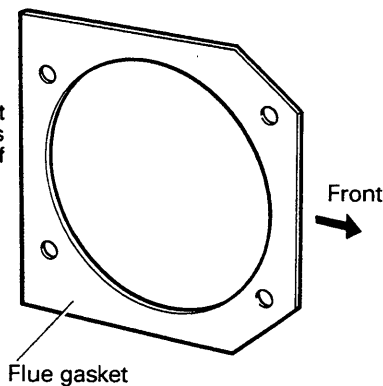

Flue gasket

18

## REASSEMBLE THE BOILER

- Remove the two screws securing the fan assembly to the flue hood and remove the fan assembly. Take care not to damage the gasket on the base of the fan.
- For right hand flue:** With the opening in the top of flue hood at the rear, slide the flue hood under the returns on the sides of the heat exchanger top frame. Take care to ensure that the pressure switch sensing pipe is engaged in its guide bracket on the rear of the flue hood.  
  
2a. Fit the flue tube sleeve (supplied loose behind the bottom cover) over the fan outlet and push fully home. Position the fan assembly so that the flue tube sleeve fits over the inner flue tube. Push the fan assembly onto the inner tube and secure to the flue hood using the two screws previously removed. **Note:** The extended hex hd screw should be used at the rear of the fan assembly.  
  
2b. Secure the flue hood to the heat exchanger top frame using the one screw at the front, previously removed. Reconnect the 3-way plug and socket for the fan leads.
- For left hand flue:** With the opening in the top of the flue hood at the front, slide the flue hood under the returns on the sides of the heat exchanger top frame. Take care to ensure that the pressure switch sensing pipe is engaged in its guide bracket on the rear of the flue hood. Refit the fan assembly as described above in 2a and 2b.
- Make good the gap on the inside wall around the flue tube.

19

## FIT THE OUTER SEALING PLATE

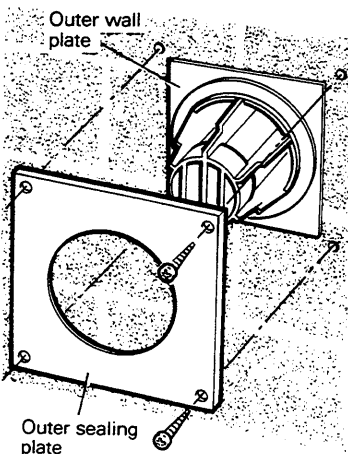

- Remove any covering from the terminal. Position the sealing plate over the terminal and secure to the wall with four 1" lg No. 8 screws (supplied with the flue assembly).

- Make good the outside wall around the flue duct.  
**Note:** The outer sealing plate need not be used if the wall is made good up to the terminal.
- Place the outer sealing plate over the terminal and mark the position of the four fixing holes.
- Remove the sealing plate and drill and plug the fixing holes, suitable for 1" lg No. 8 woodscrews.  
**Note:** The terminal should be covered before drilling to prevent debris entering the terminal.

20

## CONNECT THE GAS SUPPLY

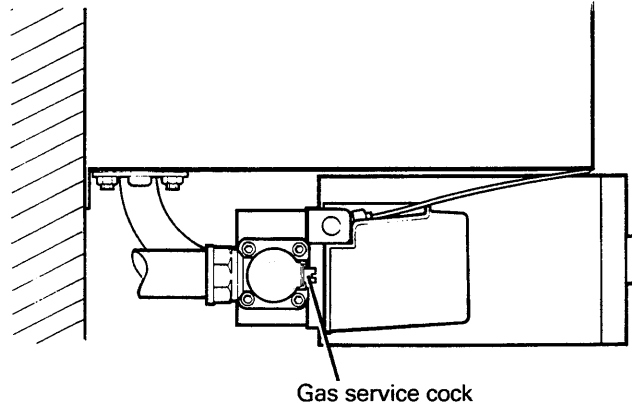

Gas service cock

- Connect a 15 mm gas supply to the service cock.  
**Note:** The gas supply must be directly out of the wall or from below as the case side panels extend below the service cock. See frame 3.
- Pressure test the gas supply for soundness and purge the supply in accordance with BS6891.

## 21 CONNECT THE POWER SUPPLY CABLE

1. Remove the three screws (one at the left hand side and two underneath) securing the control box front and pull it forward and lower.
2. Slacken the two screws in the cable clamp from below the control box. Feed the power supply cable through the large grommet in the back of the control box and under the clamp.
3. Connect the wires, brown to L and blue to N on the terminal block and green and yellow to the earthing stud ( $\perp$ ). See wiring diagram and frame 22.
4. Keep the control box front in the open position, take up excess slack in the power supply cable between the the terminal block and the cable clamp, then tighten the cable clamp screws. Check that the control box front will open and close freely without straining the power supply cable.  
**Note:** When connecting the power supply cable to the terminal block and earthing stud, ensure that the length of the earth wire is such, that if the power supply cable slips out of the cable clamp the live and neutral wires become taut before the earth wire.
5. The pump lead and any external controls wiring should be passed through the large grommet and connected to the terminal block. See wiring diagram.
6. If a room thermostat is to be fitted remove link Pump L - 2 on the terminal block and connect the room thermostat in its place. See wiring diagram.
7. Close the control box and secure with three screws if the programmer kit is not to be fitted.

## 22 FIT THE PROGRAMMER KIT

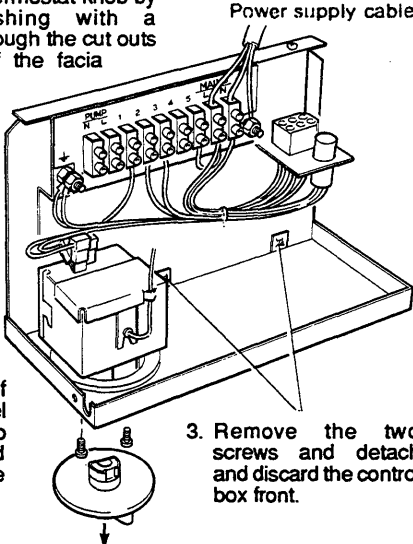
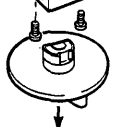
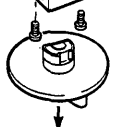
1. Remove the thermostat knob by carefully pushing with a screwdriver through the cut outs in the back of the facia panel.  

2. From the front of the facia panel remove the two screws and remove the thermostat.  

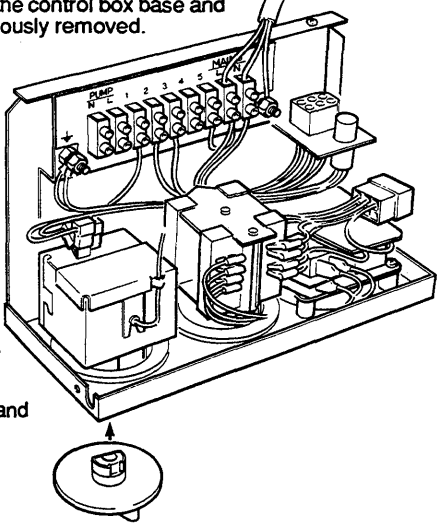
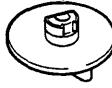
3. Remove the two screws and detach and discard the control box front.  

## 23 Programmer Kit - continued

4. Fit the programmer panel to the control box base and secure with two screws previously removed.  

5. Fit the thermostat to the programmer panel ensuring that the capillary is uppermost. Secure with two screws.
6. Replace the thermostat knob.
7. Connect the 6-way programmer plug and socket.
8. Remove links 5 - 4 and 4 - 2. See wiring diagram.
9. Close the control panel and secure with three screws.  

## 12. COMPLETE THE INSTALLATION

After connecting the water connections, see water system schematics, page 5 thoroughly flush the whole system without the pump in position. Ensure that all valves are open. With the pump fitted, fill, vent and check for water soundness, rectifying where necessary.

## 13. COMMISSIONING

See page 12 for boiler controls.

Ensure that the electricity supply is OFF and the boiler thermostat set at O. If an Orion programmer is fitted set the programme selector to 'Constant'. Remove the screw securing the gas valve cover and lift off cover. Loosen the gas valve inlet pressure test point screw one turn. Turn on the gas supply and open the gas service cock (the cock is closed when the operating slot is vertical) to purge in accordance with BS6891. Retighten the test point screw and test for gas soundness around the screw. Close the gas service cock.

With the gas supply isolated check the ignition sequence as follows:

Check that all system controls are calling for heat. Switch on the electricity supply and set the boiler thermostat to 7. The automatic ignition sequence will start. The fan will start and after a purge period of about 10 seconds a click will be heard indicating that the start gas solenoid has opened, the ignition sparks will also be heard. The ignition sparks will continue until the pilot is lit. As the gas supply is not yet turned on the ignition sparks will continue until either the electricity supply is switched off or the boiler thermostat is set to O.

Having checked the above sequence the pilot flame and burner setting pressure must be checked.

1. Set the boiler thermostat to O.
2. Remove the burner setting pressure test point screw on the gas valve manifold and connect a pressure gauge.
3. Turn on the gas supply and set the boiler thermostat to 7. The boiler will go through the ignition sequence and the pilot will light. A second or so after the pilot is lit the main gas solenoid will open and the main burner will light. Test for gas soundness around the pilot connections using a suitable leak detecting fluid.

**Note:** The pilot burner is turned off every time the main burner is off. The ignition sequence is automatically activated when the boiler thermostat requires heat.

4. The pilot flame is not adjustable. Check that the flame (35 to 40 mm long) envelops the electrode and extends to 10 mm past it.
5. With the main burner alight, test the integral gas supplies and joints for soundness using a suitable leak detection fluid.
6. Check the operation of the full sequence control and boiler thermostat by setting the boiler thermostat to O, the main burner and pilot will go out, and then setting it to 7 and the pilot and main burner will light.
7. Allow the burner to run for 10 minutes and if necessary adjust the burner setting pressure to give the heat input required. Turn the governor adjusting screw anticlockwise to decrease the burner setting pressure.

**Note:** The main burner setting pressure is factory set to the maximum input. See Technical Data, page 3 for the boiler ratings and setting pressure.

8. Set the boiler thermostat to O, disconnect the pressure gauge and replace the pressure test point screw. Set the boiler thermostat to 7 to light the main burner and test for gas soundness around the pressure test point screw using a suitable leak detecting fluid.
9. Ensure the seal is intact around the case front panel, place it in position over the boiler and secure with three screws. Tighten sufficiently to form a seal.
10. Replace the gas valve plastic cover and secure with its screw. Ensure the cable clamp is located correctly in the cover.
11. Check that the arrow on the data label (on the case bottom panel) is against the correct boiler rating.
12. When the system has been tested turn the boiler off (set the boiler thermostat to O), drain the water while it is still hot in order to complete the flushing process. Refill, vent and make a final check for water soundness.

#### 14. BOILER CONTROLS

(case front panel and gas valve cover removed)

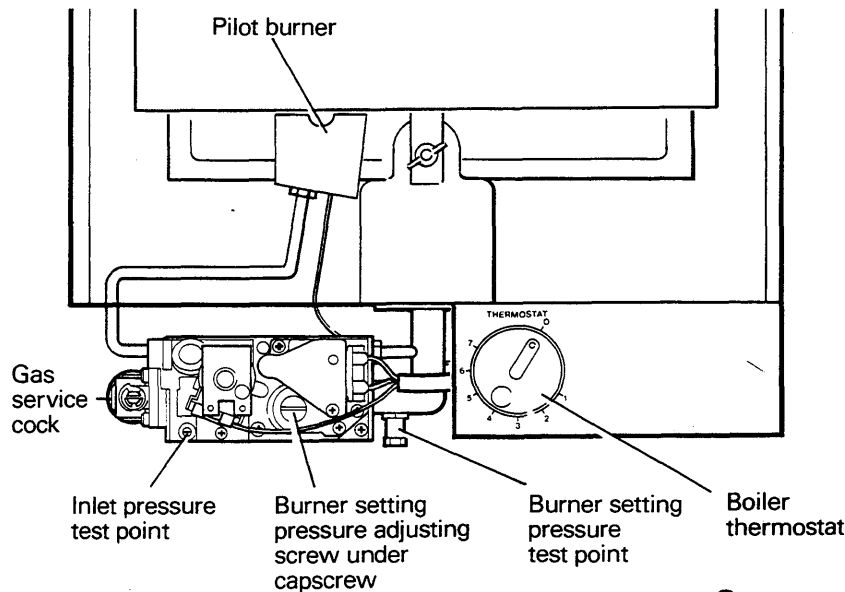

#### 15. FINAL ASSEMBLY AND HANDING OVER THE INSTALLATION

1. Secure the side panel(s) to the chassis top with the screws previously removed.
2. Slide the bottom case panel into the returns on the side panels ensuring that the data label is on the inside and secure to the side panels with two screws previously removed.
3. Place the bottom cover in position and push fully home to engage the fixing pins.
4. If a programmer is fitted, set the clock to the correct time (do not rotate the dial anticlockwise) and set the programme selector switches to the required settings. See User instructions.
5. Hand the User instructions to the User and instruct in the safe operation of the boiler and controls.
6. Advise the User of the precautions necessary to prevent damage to the system and to the building in the event of the system remaining inoperative during frost conditions.
7. Advise the User that for continued efficient and safe operation of the boiler it is important that adequate servicing is carried out at least once a year by a qualified service engineer or the local Gas Region.
8. Leave a permanent card attached to the boiler giving:
  - a. Name and address of installer.
  - b. Date of installation.
  - c. A wiring diagram of the system.

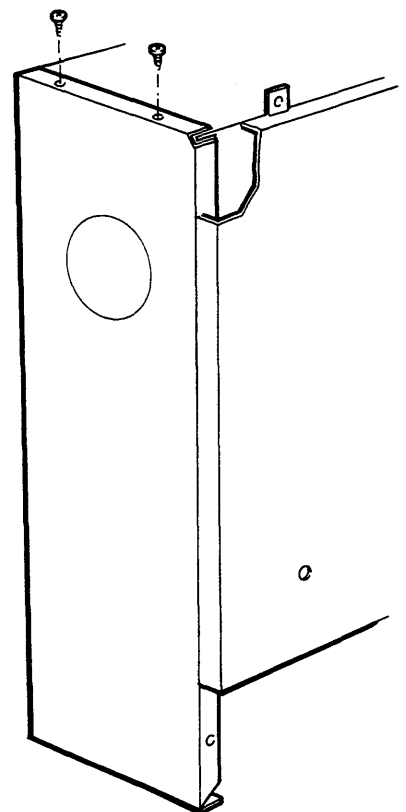

## 16. ANNUAL SERVICING

The following aspects of the boiler and installation should be examined, and rectified as necessary.

1. Run the boiler and check the operation of its controls, observe the flame picture and ensure that the boiler responds to any switches and programmer.
2. Check the installation of the flue terminal and ensure it is not obstructed.
3. Remove the combustion fan and ensure that it is clean and free of debris. Check the impellor for freedom of rotation.
4. Remove the flue hood and check if the heat exchanger or burner requires cleaning.
5. Examine the main injector orifice and ensure it is clear and undamaged.
6. If a sufficiently large pilot flame cannot be achieved examine the pilot injector orifice to ensure it is clear and undamaged.
7. When refitting the case front panel check that the seal is in good condition and compresses satisfactorily.

On completion of the service run the boiler and ensure that it operates satisfactorily.

The boiler data label is positioned on the case bottom panel.

The procedure for Annual Servicing is given in frames 24 to 29.

**WARNING:** Before commencing work set the boiler thermostat to O. Allow the boiler to cool and isolate the electricity supply. Pull the bottom cover forwards to disengage the fixing pins and turn off the gas supply at the gas service cock.

**IMPORTANT:** Always test for gas soundness after completing any servicing of gas carrying components and carry out functional checks of controls.

24

### DISMANTLING

1. Unscrew the three case front panel fixing screws (two at the top and one at the bottom) and lift off the case front.
2. Remove the two screws securing the case bottom panel to the side panels and slide out the bottom panel.
3. Place the case parts safely aside to avoid possible damage.
4. If side exit flue is used remove the two screws securing the fan to the flue hood (an extended hex hd screw is used to secure the rear of the fan) and slide it away from the flue to disengage the flue tube sleeve (on the fan outlet) from the flue. Take care not to damage the gasket on the base of the fan.
5. Disconnect the 3-way plug and socket for the fan leads and remove the fan. Remove the screw securing the front of the flue hood to the heat exchanger top frame and slide out the flue hood, see frame 10.
6. Remove the screw securing the gas valve cover and lift off cover.

25

### Dismantling - continued

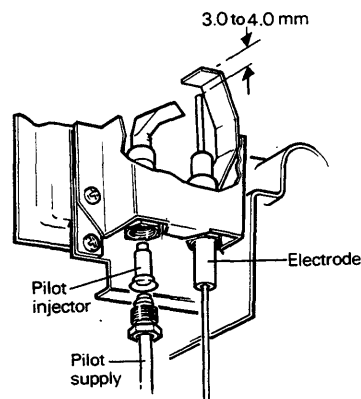

7. Undo the securing nut and remove the electrode from the pilot assembly.
8. Undo the tubing nuts and disconnect the pilot supply from both the pilot assembly and gas valve.
9. Carefully remove and retain the pilot injector.

26

### Dismantling - continued

10. From underneath the base of the chassis remove the two pozi screws securing the burner manifold and the one screw securing the front of the burner and withdraw the burner.
11. Remove the thermostat capillary clip from the bottom left hand corner of the heat exchanger.
12. Support the base of the heat exchanger side insulation tray. Remove the three screws securing the retaining angle to the heat exchanger and heat exchanger top frame. Remove the angle by lowering slightly and withdrawing it.
13. Remove the side insulation tray by sliding it down out of the heat exchanger top frame and withdrawing it forwards.
14. Repeat for the opposite side insulation tray.
15. Remove the three pozi screws and washers securing the motor assembly to the fan housing and carefully withdraw the motor complete with impellor from the fan housing.

27

### CLEANING THE BOILER

1. Examine the fan impellor and carefully clean if necessary.
2. Brush both sides and centre section of the heat exchanger using a suitable brush. Remove any fallen deposits from the boiler base.
3. Turn the burner upside down and tap gently to remove any debris.
4. Clean the pilot burner and electrode with a fine wire brush if necessary.
5. Unscrew the injector from the burner manifold, clean by blowing through or washing. Do NOT clear the injector with a pin or wire. Clean the pilot injector in a similar manner.
6. To clean or replace the pilot filter in the gas valve refer to frame 41.
7. Examine the condition of the side insulation material and replace if necessary by sliding it out of the tray.

**28****REASSEMBLY**

1. Replace the burner injector using a small amount of jointing compound.
2. Replace the side insulation trays (slide in and up to engage them in the heat exchanger top frame) and retain with the retaining angles, one side at a time (the top of the retaining angles go under the heat exchanger top frame).
3. Locate the thermostat capillary with the clip previously removed.
4. Replace the burner assembly and secure with three screws previously removed.
5. Replace the pilot injector, reconnect the pilot supply to the gas valve and pilot assembly and replace the electrode.
6. Remove the two screws securing the pilot shield, lift off the pilot shield and check that the spark gap, see frame 25, is 3.0 to 4.0 mm. Replace the pilot shield.
7. Replace the fan motor and impellor assembly.
8. Refit the flue hood by sliding it under the returns on the sides of the heat exchanger top frame. Take care to ensure that the pressure switch sensing pipe is engaged in its guide bracket on the rear of the flue hood. **Note:** For RH or rear flue exit the opening in the top of the flue hood should be at the rear, for LH flue exit it should be at the front.
9. Ensure that the flue tube sleeve is in position over the fan outlet and engage the fan assembly into the flue.

**29****Reassembly - continued**

10. If the fan was removed ensure that the gasket on its base is intact, renew if necessary. Secure the fan assembly to the flue hood using the two screws previously removed. **Note:** The extended hex hd screw should be used at the rear of the fan assembly.
11. Secure the flue hood to the heat exchanger top frame using the screw previously removed. Reconnect the 3-way plug and socket for the fan leads.
12. Refer to the commissioning instructions, page 11. Check the pilot flame, test for gas soundness and check the burner setting pressure.
13. Ensure the seal is intact around the case front panel. Place it in position over the boiler and secure with three screws. Tighten sufficiently to form a seal.
14. Slide the bottom case panel into the returns on the side panels ensuring that the data label is on the inside and secure to the side panels with two screws previously removed.
15. Place the bottom cover in position and push fully home to engage the fixing pins.

**17. REPLACEMENT OF PARTS**

The procedure for the replacement of parts is given in frames 30 to 45.

**WARNING:** Before commencing work set the boiler thermostat to O. Allow the boiler to cool and isolate the electricity supply. Pull the bottom cover forwards to disengage the fixing pins and turn off the gas supply at the gas service cock.

**IMPORTANT:** Always test for gas soundness after completing any exchange of gas carrying components and carry out functional checks of controls.

**30****TO REPLACE THE ELECTRODE**

1. Remove the case front panel and bottom panel. See frame 24.
2. Undo the securing nut and remove the electrode from the pilot assembly.
3. Remove the three screws (one at the left hand side and two underneath) securing the control box front. Pull it forward and lower.
4. Disconnect the electrode lead from the circuit board inside the control box. Withdraw the electrode lead through the side of the control box.
5. Fit the new electrode in reverse order ensuring that the grommet is fitted in the side of the control box.
6. Remove the two screws securing the pilot shield, lift off the pilot shield and check that the spark gap, see frame 25, is 3.0 to 4.0 mm. Replace the pilot shield.
7. Refer to the commissioning instructions, page 11. Light the boiler to ensure correct operation.
8. Replace the case front panel, bottom panel (ensuring that the data label is on the inside) and bottom cover.

**31****TO REPLACE THE PILOT INJECTOR**

1. Remove the case front panel and bottom panel. See frame 24.
2. Undo the tubing nut at the pilot supply and carefully disconnect the pilot supply.
3. Carefully remove the pilot injector. See frame 25.
4. Fit a new injector and reconnect the pilot supply.
5. Refer to the commissioning instructions, page 11. Light the boiler, test the pilot supply for gas soundness and check the pilot flame.
6. Replace the case front panel, bottom panel (ensuring that the data label is on the inside) and bottom cover.

**32****TO REPLACE THE PILOT BURNER**

1. Remove the case front panel and bottom panel. See frame 24.
2. Undo the securing nut and remove the electrode from the pilot assembly.
3. Undo the tubing nut and carefully disengage the pilot supply from the pilot assembly. Carefully remove the pilot injector. See frame 25.
4. Remove the two screws securing the pilot shield and lift off the pilot shield.
5. Remove the remaining screw securing the pilot burner and remove the pilot burner.
6. Fit a new pilot burner and secure with two screws. Replace the injector, pilot supply and electrode. Check that the spark gap, see frame 25, is 3.0 to 4.0 mm.
7. Remove the uppermost screw securing the pilot burner and replace the pilot shield securing it with two screws.
8. Refer to the commissioning instructions, page 11. Light the boiler, test the pilot supply for gas soundness and check the pilot flame.
9. Replace the case front panel, bottom panel (ensuring that the data label is on the inside) and bottom cover.

**33****TO REPLACE THE BURNER**

**NOTE:** The burner fitted may be either Furigas (silver) or Bray (blue) either may be used as a replacement for the other.

1. Remove the case front panel and bottom panel. See frame 24.
2. Remove the burner as described in frames 24, 25 and 26, paras 6 to 10.
3. Remove the pilot burner as described in frame 32 and fit it to the new burner.
4. Fit the new burner and reassemble as described in frame 28 paras 4 to 6.
5. Refer to the commissioning instructions, page 11. Light the boiler, test for gas soundness and check the pilot flame.
6. Replace the case front panel, bottom panel (ensuring that the data label is on the inside) and bottom cover.

**34****TO REPLACE THE BOILER THERMOSTAT**

1. Remove the case front panel and bottom panel. See frame 24.
2. Remove the thermostat capillary clip from the bottom left hand corner of the heat exchanger.
3. Remove the thermostat phial fixing (screw or split pin) from the thermostat pocket in the heat exchanger and withdraw the phial from the pocket.
4. Remove the three screws (one at the left hand side and two underneath) securing the control box front. Pull it forward and lower.
5. Remove the thermostat knob by carefully pushing with a screwdriver through the cut outs in the back of the facia panel.
6. Disconnect the leads from the thermostat, noting their position.
7. From the front of the facia panel remove the two fixing screws and remove the thermostat.
8. When fitting the new thermostat to the facia panel ensure that the capillary is uppermost.

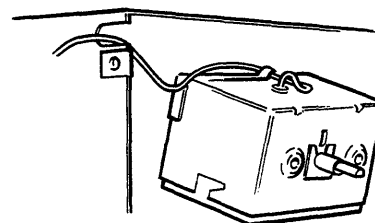
**35****Boiler Thermostat - *continued***

9. Reassemble in reverse order ensuring that the thermostat leads are correctly fitted, see wiring diagram, and that the capillary follows the same route as the discarded one. **Note:** A cut out is provided in the control box side for the capillary.
10. Refer to the commissioning instructions, page 11 and light the boiler. Allow it to heat up and check that the thermostat will switch the boiler off when turned to a low setting.
11. Replace the case front panel, bottom panel (ensuring that the data label is on the inside) and the bottom cover.

**36****TO REPLACE THE IGNITION CIRCUIT BOARD**

1. Remove the case bottom panel. See frame 24.
2. Remove the three screws (one at the left hand side and two underneath) securing the control box front. Pull it forward and lower.
3. Disconnect the electrode lead and three wiring connectors from the circuit board. Remove the ignition circuit board from the four plastic pillars securing it to the back of the control box.
4. Reassemble in reverse order with a new board. Refer to the commissioning instructions, page 11 and light the boiler to check operation.
5. Replace the case bottom panel (ensuring that the data label is on the inside) and bottom cover.

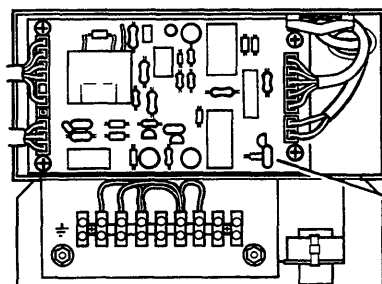

Ignition circuit board

**37****TO REPLACE THE GAS VALVE**

**ENSURE THAT THE GAS SUPPLY IS OFF**

1. Remove the case front panel and bottom panel, see frame 24. Remove the two screws securing the left hand side panel to the top of the boiler and remove the panel. If the flue exits from the left, slide the side panel along the flue.
2. Remove the screw securing the gas valve cover and lift off cover.
3. Disconnect the push-on terminals and unscrew the earth terminal. The polarity of these wires is not important but the grey and blue lead must go to the inlet (pilot) solenoid and the white and black lead to the outlet (main) solenoid. See wiring diagram.
4. Disconnect the pilot supply from both the pilot assembly and gas valve.
5. Remove the eight 3 mm socket screws securing the gas valve (four to the service cock and four to the burner manifold).
6. Withdraw the gas valve and discard the 'O' rings in the service cock and burner manifold flanges.

38

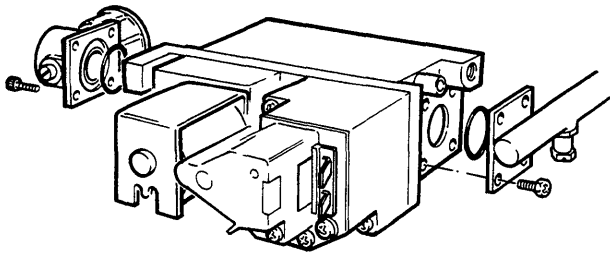
**Gas valve - continued**

- Using new 'O' rings in the service cock and burner manifold flanges (both 'O' rings are the same size) reassemble the new valve to the boiler in reverse order. Do not replace the plastic gas valve cover at this stage.
- Refer to the commissioning instructions, page 11. Check the pilot flame, test for gas soundness, check the burner setting pressure and replace the gas valve cover.
- Replace the case side panel, front panel, bottom panel (ensuring that the data label is on the inside) and bottom cover.

40

**TO REPLACE THE GAS VALVE SOLENOID**

Retaining clip

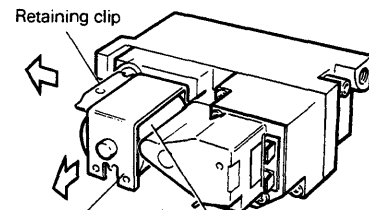

Mounting bracket Solenoid

- Remove the case bottom panel. See frame 24.
- Remove the screw securing the gas valve plastic cover and lift off cover.
- Disconnect the push-on terminals and unscrew the earth terminal. The polarity of these wires is not important but the grey and blue lead must go to the inlet (pilot) solenoid and the white and black lead to the outlet (main) solenoid. See wiring diagram.

- Carefully prise out the retaining clip from behind the solenoid and lift off the solenoid and its mounting bracket.
- Position the new solenoid into the mounting bracket and reassemble in reverse order.
- Refer to the commissioning instructions, page 11. Light the boiler to check the gas valve operation.
- Replace the case bottom panel (ensuring that the data label is on the inside) and bottom cover.

42

**TO REPLACE THE PROGRAMMER (if fitted)**

Refer to illustration in frame 23.

- Remove the case bottom panel. See frame 24.
- Remove the three screws (one at the left hand side and two underneath) securing the programmer and pull it forward and lower.
- Remove the thermostat knob by carefully pushing with a screwdriver through the cutouts in the back of the fascia panel.
- Disconnect the 6-way programmer plug and socket.
- From the front of the fascia panel remove the two fixing screws and remove the thermostat.
- Remove the two screws securing the programmer to the control box and remove the programmer.
- Reassemble in reverse order using a new programmer. Ensure the thermostat capillary is uppermost when fitting it to the programmer.
- Refer to the commissioning instructions, page 11. Light the boiler and check controls. Set the programmer clock to the correct time and the selector switch to its previous setting.
- Replace the case bottom panel (ensuring that the data label is on the inside) and bottom cover.

39

**TO REPLACE THE BURNER INJECTOR**

- Remove the case front panel and bottom panel. See frame 24.
- Remove the burner assembly as described in frames 24, 25 and 26, paras 6 to 10.
- Unscrew the injector from the burner manifold.
- Screw in a replacement injector, using a small amount of jointing compound.
- Replace the burner as described in frames 28, paras 4 to 6.
- Refer to the commissioning instructions, page 11. Check the pilot flame and test for gas soundness.
- Replace the case front panel, bottom panel (ensuring that the data label is on the inside) and bottom panel.

41

**TO REPLACE THE PILOT FILTER**

**NOTE: It is extremely unlikely that the pilot filter will become blocked. If the pilot injector and pilot supply are clear and the filter is still suspect proceed as follows:**

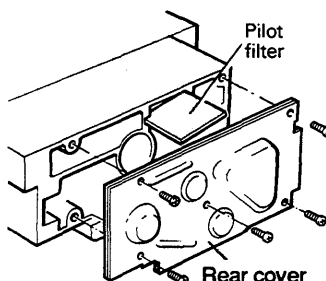
**ENSURE THAT THE GAS SUPPLY IS OFF**

- Remove the gas valve as described in frame 37.
- Remove the five screws securing the rear cover plate and carefully remove it. Discard the gasket.
- Carefully remove the pilot filter and replace with a new one.
- Replace the rear cover using a NEW gasket and secure by evenly tightening the five screws.

- Replace the gas valve in reverse order to frame 37.
- Refer to the commissioning instructions, page 11. Light the boiler and test for gas soundness.
- Replace the case side panel, front panel, bottom panel (ensuring that the data label is on the inside) and bottom cover.

43

**TO REPLACE THE AIRFLOW PRESSURE SWITCH**

**The airflow pressure switch is mounted on the underside of the chassis top plate.**

- Remove the case front panel and flue hood and fan assembly. See frame 24.
- Carefully disconnect the flexible tube from the pressure switch and disconnect the three leads, noting their position.
- Remove the two screws securing the pressure switch mounting bracket to the underside of the chassis top plate.
- Using a new pressure switch (supplied with mounting bracket) secure the mounting bracket to the underside of the chassis top plate.
- Reconnect the leads to the pressure switch. See wiring diagram.
- Reconnect the flexible tube.
- Replace the flue hood and fan assembly as described in frames 28 and 29, paras 8 to 11.
- Refer to the commissioning instructions, page 11. Light the boiler and check that the pressure switch allows the main burner to light.
- Replace the case front panel and bottom cover.



**44**

## **TO REPLACE THE FAN MOTOR AND IMPELLOR ASSEMBLY**

1. Remove the case front panel. See frame 24.
2. Remove the two screws securing the fan assembly to the flue hood and slide it away from the flue to disengage the flue tube sleeve (on the fan outlet) from the flue. Take care not to damage the gasket on the base of the fan, renew if necessary.
3. Disconnect the 3-way plug and socket for the fan leads and remove the fan assembly.
4. Remove the three pozi hd screws and washers securing the motor assembly to the fan housing and carefully withdraw the motor complete with impellor from the fan housing.
5. Reassemble in reverse order using the new assembly.
6. Refer to the commissioning instructions, page 11. Light the boiler and check that the fan switches on and off as the main burner cycles on and off respectively.
7. Replace the case front panel and bottom cover.

**45**

## **TO REPLACE THE HIGH LIMIT THERMOSTAT**

**The high limit thermostat is positioned behind the control box. The mounting bracket is secured to the base of the control box with two screws.**

1. Remove the case front panel and bottom panel, see frame 24. Remove the two screws securing the right hand side panel to the top of the boiler and remove the panel. If the flue exits from the right, slide the side panel along the flue.
2. Remove the two screws securing the thermostat mounting bracket to the base of the control box.
3. Remove the nut securing the thermostat body to its mounting bracket and disconnect the two wires. The polarity of these wires is not important.
4. Remove the split pin and thermostat phial from the thermostat pocket in the right hand flow manifold.
5. Carefully push out the large black sealing grommet in the top right hand corner of the chassis and remove the thermostat capillary. Unclip the capillary from the clips on the side of the chassis.
6. When fitting the new thermostat reassemble in reverse order and check that the manual reset button on the thermostat is depressed.
7. Refer to the commissioning instructions, page 11 and light the boiler.
8. Replace the case front panel, bottom panel (ensuring that the data label is on the inside) and bottom cover.

# 18. WIRING DIAGRAMS

## a. Illustrated wiring diagram

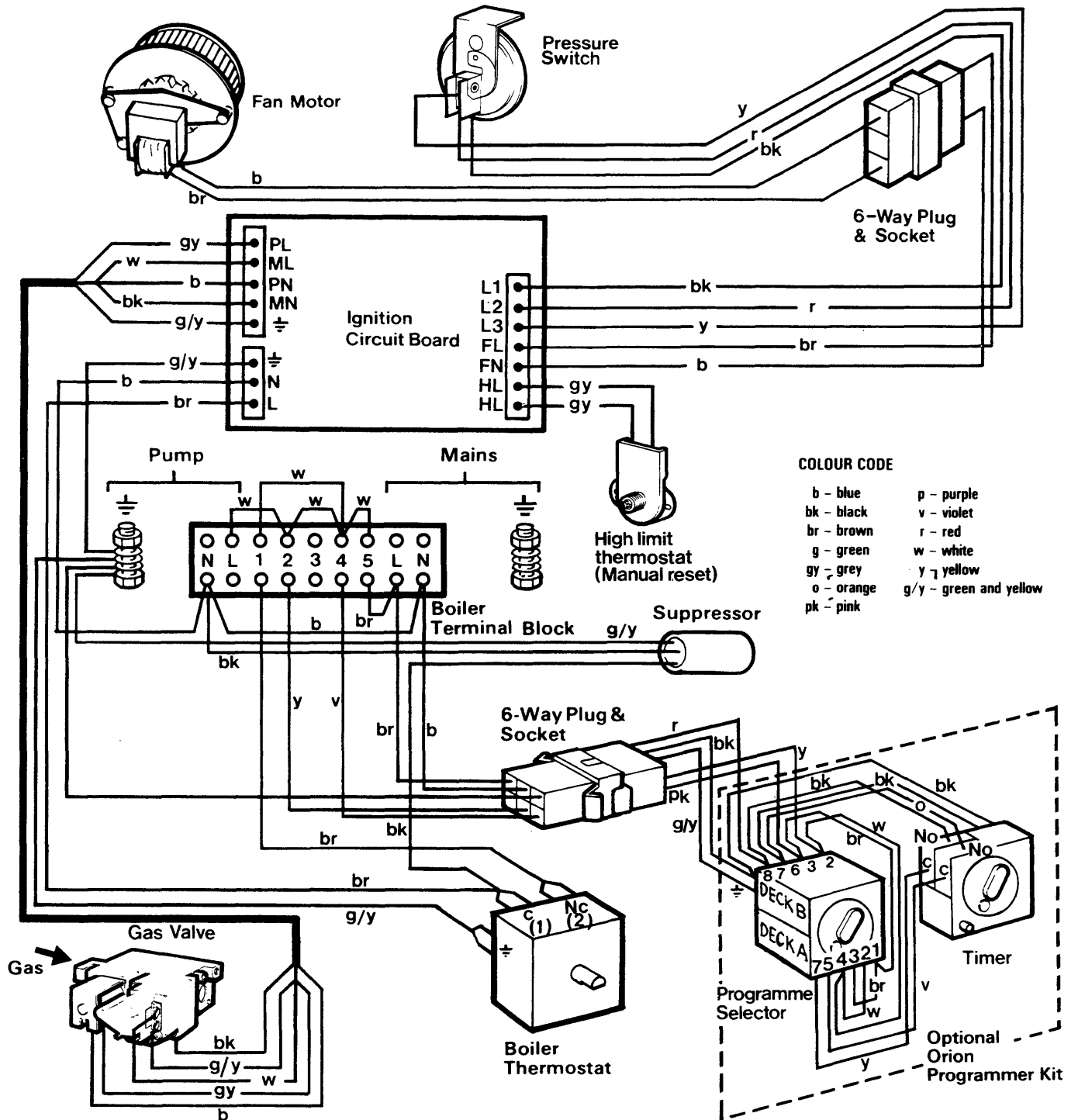

Note: If an Orion programmer is fitted remove links 5-4 and 4-2.  
 If a room thermostat is fitted remove link pump L-2 and connect the room thermostat in its place.

b. Functional flow wiring diagram without programmer

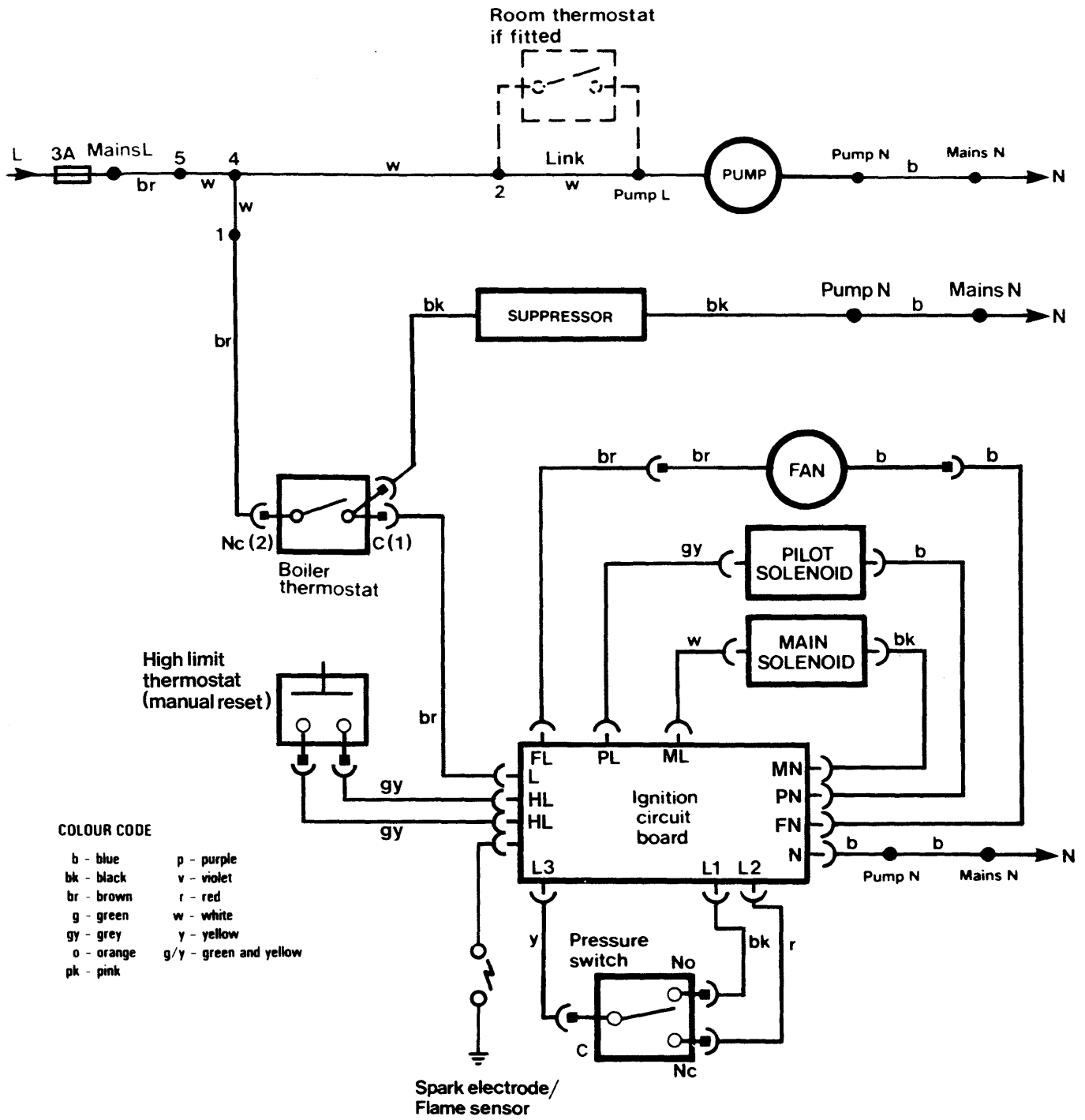

If a room thermostat is fitted, remove link Pump L-2 and connect the room thermostat in its place.

c. Functional flow wiring diagram with Orion programmer

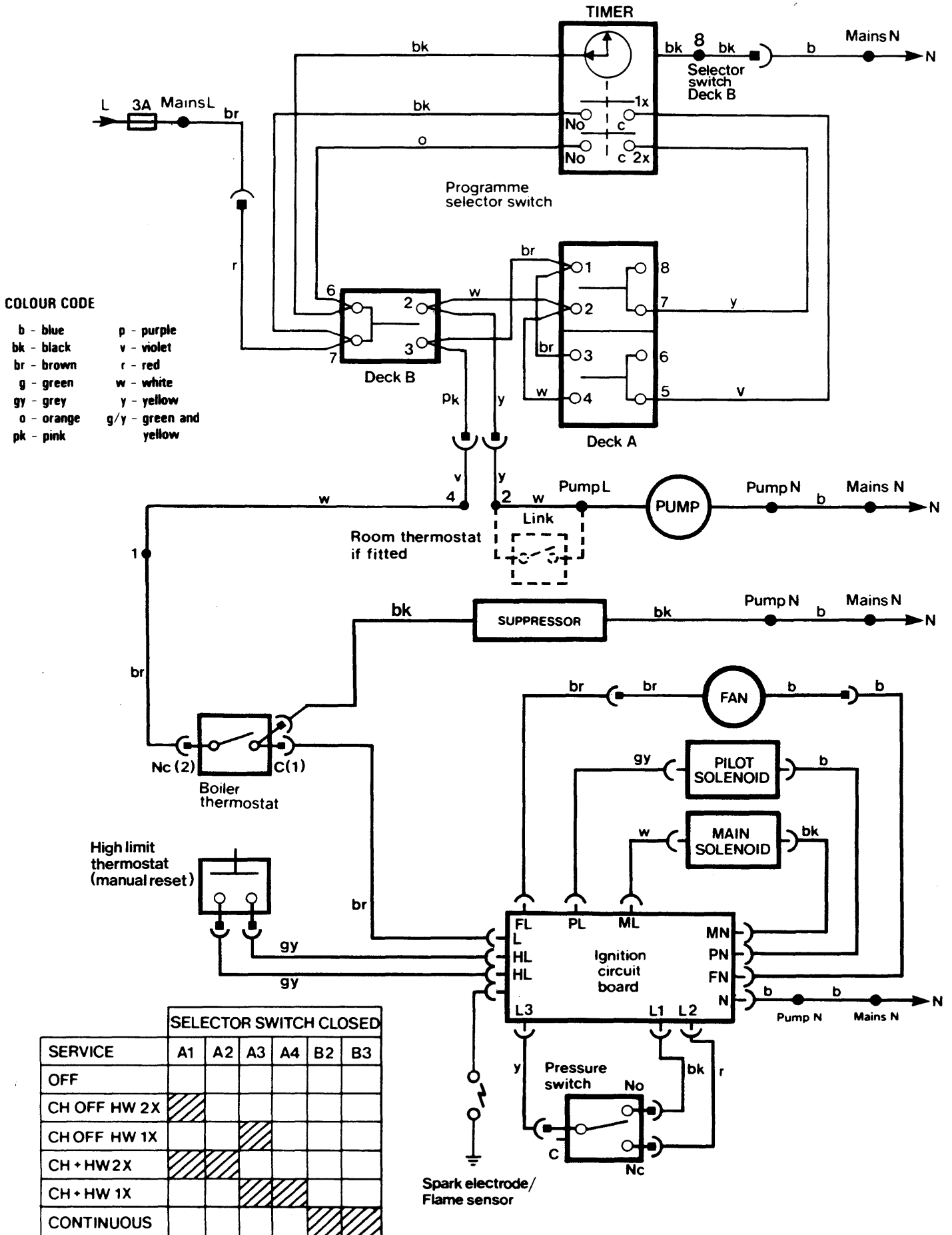

Preliminary electrical system checks as contained in the BGC multimeter instructions book are the first electrical checks to be carried out during a fault finding procedure. On completion of the service/fault finding task which has required the breaking and remaking of electrical connections, then the checks — A. Earth Continuity, C. Polarity and D. Resistance to Earth — must be repeated.

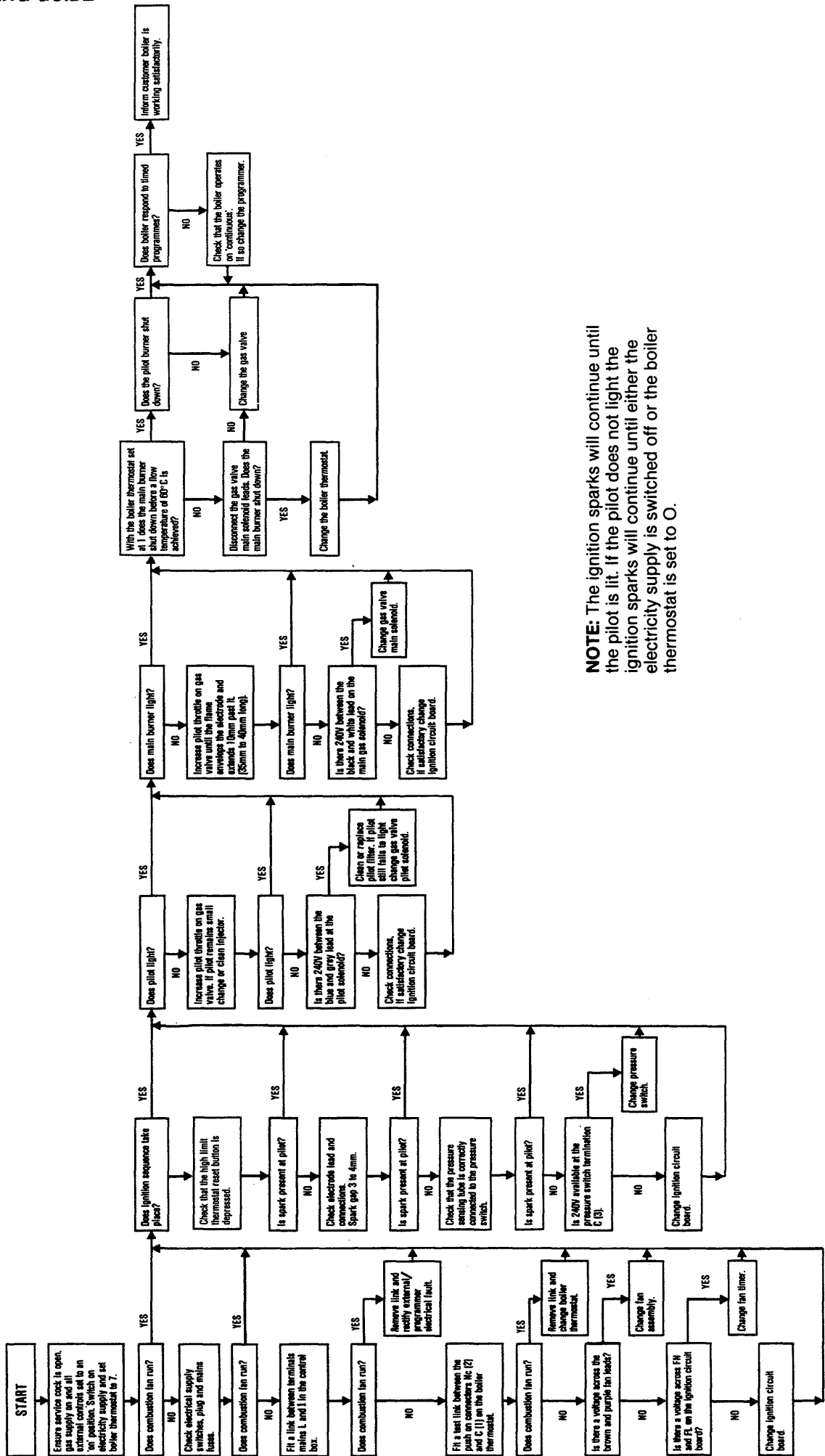

**NOTE:** The ignition sparks will continue until the pilot is lit. If the pilot does not light the ignition sparks will continue until either the electricity supply is switched off or the boiler thermostat is set to O.

20. EXPLODED VIEW

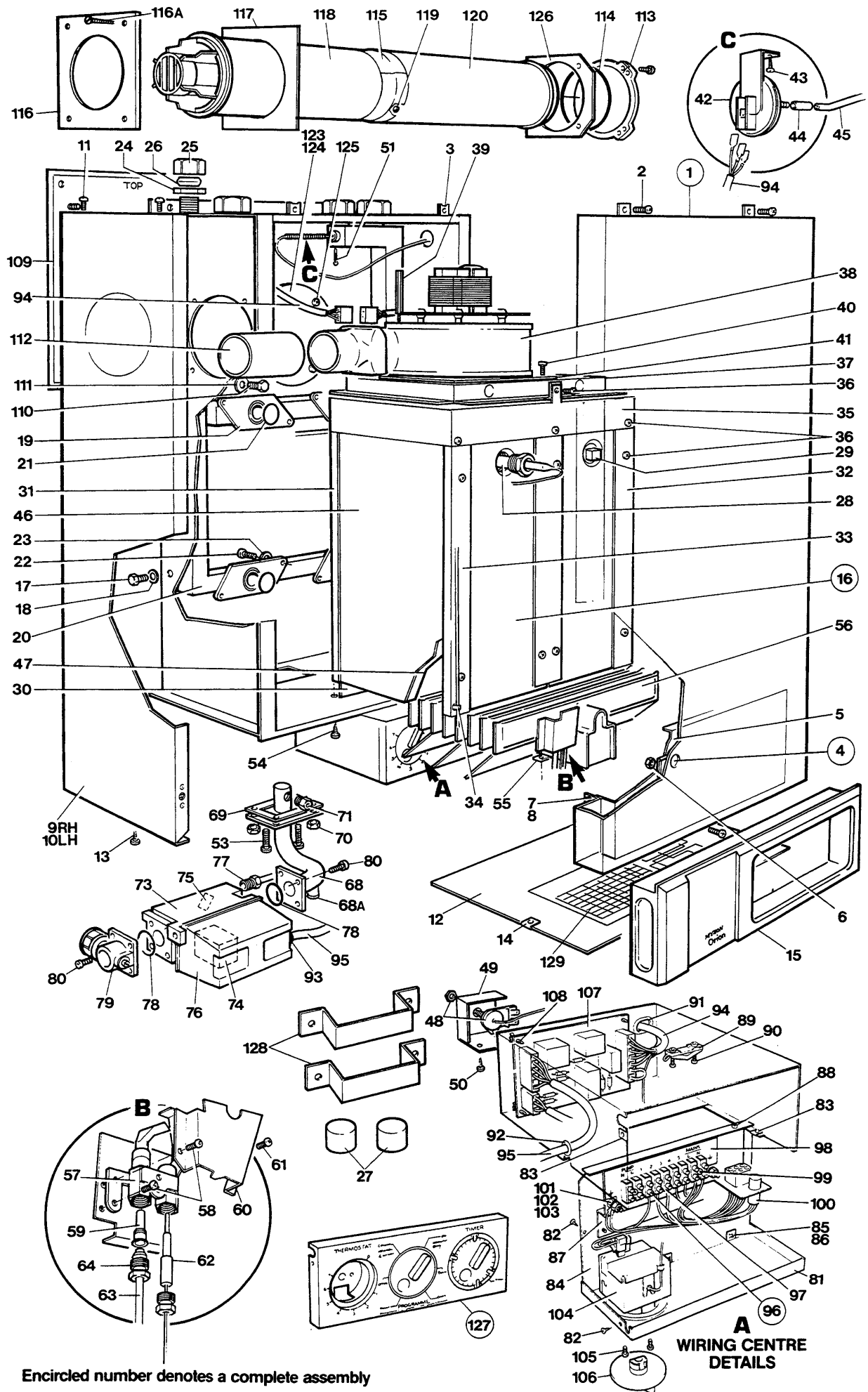

Encircled number denotes a complete assembly

21. SHORT LIST SPARE PARTS

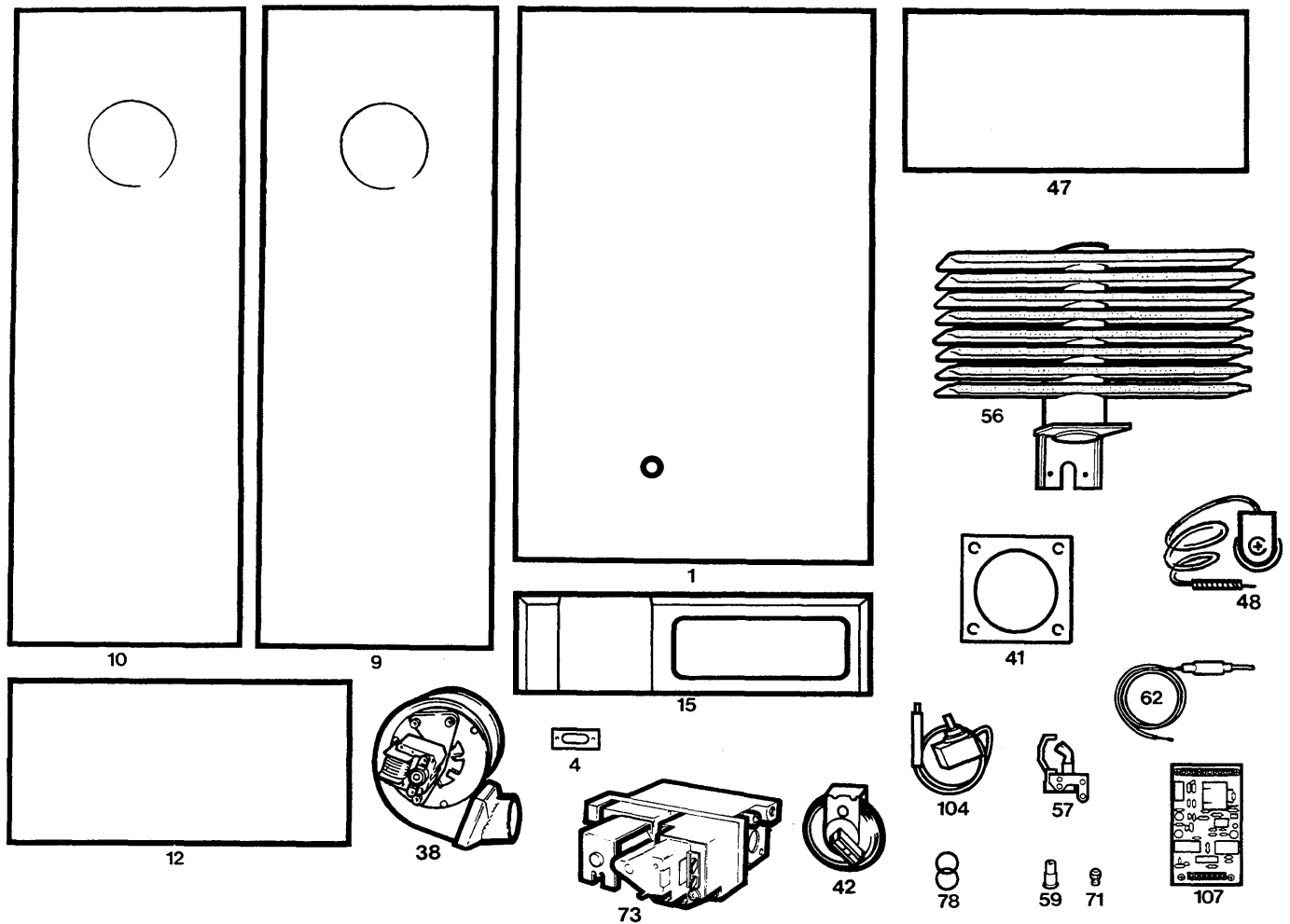

Key No.	GC No.	Description	Qty.	Part No.
1	377 025	Case front panel assembly	1	309A268
4	332 640	Window assembly	1	309A169
9		R/H side panel assembly	1	309A589
10		L/H side panel assembly	1	309A588
12	332 639	Bottom panel	1	309C102
15	332 641	Bottom cover	1	309A277
38		Fan assembly	1	309A634
41		Fan gasket	1	309C626
42	386 608	Pressure switch	1	309S503
47	332 657	Insulation block	2	309C128
48		High limit thermostat	1	309S564
56		Burner	1	309S617
57	386 532	Pilot burner	1	Q395A1003
59	381 702	Pilot injector, 56/42A	1	45004108-005
62	377 073	Spark electrode and lead	1	402S2529
71		Main injector, 400	1	309S633
73		Gas valve	1	VR4700C4022
78	359 211	Gas valve 'O' ring	2	400-0016-7-32
104	381 677	Boiler thermostat	1	CL6P0143
106	332 666	Thermostat knob with clip	1	309S371
107	377 046	Ignition control circuit board	1	309S374

**SALES INQUIRIES:**

Sales Department  
Eastern Avenue  
Team Valley Trading Estate  
Gateshead  
Tyne & Wear  
NE11 0PG

Tel: 0191 4917500  
Fax: 0191 491 7568

**SERVICE INQUIRIES:**

Service Department  
Brooks House  
Coventry Road  
Warwick  
CV34 4LL

Tel: 01926 496896  
Fax: 01926 410006

**SPARES INQUIRIES:**

Curzon Components  
National Sales Office  
Unit 382F  
Jedburgh Court  
Eleventh Avenue  
Team Valley Trading Estate  
Gateshead  
NE11 0BQ

Tel: 0990 103030  
Fax: 0191 4876688

**TECHNICAL HELPLINE:**

Technical Department  
Brooks House  
Coventry Road  
Warwick  
CV34 4LL

Tel: 01926 410044  
Fax: 01926 410006

**TRAINING ADMINISTRATION**

Unit 5  
Titan Business Centre  
Spartan Close  
Tachbrook Park  
Leamington Spa  
Warwickshire  
CV34 6RS

Tel: 01926 430481  
Fax: 01926 882971

Registered Office: 84 Eccleston Square . London SW1V 1PX

Registered in England No. 412935

304

"All descriptions and illustrations contained in this catalogue have been carefully prepared, but we reserve the right to make changes and improvements in our products which may affect the accuracy of the information contained in this catalogue"

**OMYSON**