



## **Compact HRE**

**18 OV** (G.C. 41-291-04)

**24 OV** (G.C. 41-291-05)

**30 OV** (G.C. 41-291-06)

## **Installation, service and user instructions**

Please read these installation instructions carefully before installing and using the appliance. Keep these installation instructions with the appliance.

Always act in accordance with the instructions indicated.



Benchmark places responsibilities on both manufacturers and installers. The purpose is to ensure that customers are provided with the correct equipment for their needs, that it is installed, commissioned and serviced in accordance with the manufacturer's instructions by competent persons and that it meets the requirements of the appropriate Building Regulations. The Benchmark Checklist can be used to demonstrate compliance with Building Regulations and should be provided to the customer for future reference. Please read the Benchmark Checklist carefully, page 45, and complete all sections, as required by law, relevant to the appliance and installation. The details within the Checklist will be required in the event of any warranty work. On completion the Checklist must be left with the end user. The relevant sections of the Service Record, page 46, must be completed on each subsequent Service visit.

Installers are required to carry out installation, commissioning and servicing work in accordance with the Benchmark Code of Practice which is available from the Heating and Hotwater Industry Council who manage and promote the scheme. Visit [www.centralheating.co.uk](http://www.centralheating.co.uk) for more information.

## CONTENT



		<b>2</b>
<b>1</b>	<b>Preface</b>	<b>4</b>
1.1	Regulation.....	4
1.2	Warnings.....	4
1.3	Manual handling.....	4
1.4	Warnings on the box.....	4
1.5	Pictograms.....	4
1.6	Abbreviations and descriptions used.....	5
1.7	This manual.....	5
1.8	Service and technical support.....	5
1.9	Product identification.....	5
<b>2</b>	<b>SafEty regulations</b>	<b>6</b>
2.1	General.....	6
2.2	The installation.....	6
2.3	Approvals.....	6
2.4	Technical data.....	7
2.5	Product FiChE according to CELEX-32013R0811, ANNEX iv.....	8
2.6	Components.....	9
<b>3</b>	<b>General boiler information</b>	<b>10</b>
3.1	General.....	10
3.2	Boiler controller.....	10
3.3	Parameter list.....	10
3.4	Heat transfer.....	10
3.5	Central heating system.....	10
3.6	Room temperature control.....	10
3.7	Integrated clock.....	10
<b>4</b>	<b>OPERATION</b>	<b>11</b>
4.1	General.....	11
4.2	Central heating mode.....	11
4.3	Operating modes.....	11
4.4	Clock function.....	12
4.5	PC interface.....	12
4.6	Test programs.....	13
4.7	Frost protection.....	13
<b>5</b>	<b>Installer important points</b>	<b>14</b>
<b>6</b>	<b>Accessories</b>	<b>15</b>
<b>7</b>	<b>Installation</b>	<b>18</b>
7.1	Overall dimensions.....	18
7.2	Installation location.....	19
7.3	Installing the appliance.....	20

<b>8</b>	<b>Connection</b>	<b>21</b>
8.1	Connecting CH installation .....	21
8.2	Gas connection .....	21
8.3	Electrical connection .....	22
8.4	Condensate disposal.....	24
8.5	Flue system .....	25
<b>9</b>	<b>Commissioning the appliance</b>	<b>31</b>
9.1	Filling and venting the appliance and the installation .....	31
9.2	Commissioning the appliance .....	33
9.3	Setting and adjusting the clock functions .....	34
9.4	Additional functions .....	34
9.5	Shutting down.....	35
<b>10</b>	<b>Setting and adjustment</b>	<b>36</b>
10.1	Directly via the operating panel .....	36
10.2	Setting via the service code .....	36
10.3	Parameters .....	37
10.4	Setting maximum CH power.....	38
10.5	Adjusting pump setting .....	38
10.6	Weather– compensation adjustment.....	38
10.7	Gas-Air ratio control .....	39
10.8	Checking the gas air ratio control.....	40
10.9	Conversion to different gas type.....	44
<b>11</b>	<b>FAults</b>	<b>45</b>
11.1	Fault codes .....	45
11.2	Other faults.....	46
<b>12</b>	<b>Maintenance</b>	<b>49</b>
12.1	Disassembly .....	49
12.2	Cleaning .....	49
12.3	Assembly .....	50
12.4	Combustion .....	50
<b>13</b>	<b>Electrical Connections</b>	<b>51</b>
13.1	Wiring diagram .....	51
13.2	NTC resistances.....	51
13.3	Typical Y Plan connection .....	52
13.4	Typical S Plan connection .....	52
<b>14</b>	<b>short spares list</b>	<b>53</b>
<b>15</b>	<b>Warranty CoNDiTions</b>	<b>54</b>
<b>16</b>	<b>CE DECLARATION</b>	<b>54</b>
<b>17</b>	<b>SERVICE RECORD</b>	<b>56</b>

© 2018 Intergas Heating Ltd. All rights reserved.

The information provided applies to the standard version of the product. Intergas Heating Ltd cannot therefore be held liable for any loss or damage arising from product specifications deviating from the standard version. The available information has been compiled with all possible care, but Intergas Heating Ltd cannot be held liable for any errors in the information or for the consequences thereof.

Intergas Heating Ltd cannot be held liable for any loss or damage arising from work performed by third parties.

Subject to change.

# 1 PREFACE

## 1.1 Regulation

The Intergas boiler meets the requirements of Statutory Instrument 'The Boiler (Efficiency) Regulations'.

Intergas declares that the materials used in the manufacturing of this appliance are non-hazardous and that no substances harmful to health are contained within the appliance.

## 1.2 Warnings

Intergas accepts no responsibility for the unsatisfactory performance of the appliance or flue arising from the failure to comply with the installation and user instructions. Incorrect installation could invalidate your guarantee and may lead to prosecution.

The appliance cannot be removed from the original place of installation and transferred to another site or re-sold without prior consent from Intergas to re-register the appliance with Intergas in order to maintain the warranty.

The boiler must be installed in accordance with these instructions and the regulations currently in force. Read these instructions carefully before installing or using the appliance. It is the installers responsibility that the installation conforms to the current legislation and Standard Codes of Practice.

## 1.3 Manual handling

When moving the boiler always keep your back straight, bend your knees, don't twist, move your feet. Avoid bending forwards or sideways and keep the load as close to your body as possible. Where possible transport the boiler using a suitable trolley, sack truck or get some assistance. Grip the boiler firmly and before lifting establish where the weight is concentrated to determine the centre of gravity, repositioning yourself if necessary.

## 1.4 Warnings on the box



**This is a fragile piece of equipment: Please provide a dry storage for the appliance.**



**This is a fragile piece of equipment: Please be very careful not to drop.**



**Store the appliance upright as indicated on the box.**



**No more than three boxes should be stacked on top of each other.**

## 1.5 Pictograms

The following pictograms are used in this manual:



**CAUTION**  
Procedures which – if they are not performed with the necessary caution – can result in damage to the product, the surrounding area or the environment, or in physical injury.



**WARNING HIGH VOLTAGE**  
Risk of electrical shock.



**FROST PROTECTION**  
Procedures which must be followed to prevent frost damage.

## 1.6 Abbreviations and descriptions used

Description	Referred to as
High efficiency	HE
Intergas Compact HRE OV wall mounted gas fired boiler	Appliance
Appliance plus pipe work for central heating	CH installation
Appliance plus pipe work for domestic hot water	DHW installation

## 1.7 This manual

This manual will guide you through, installation, service and maintenance of the appliance safely. Follow the instructions carefully. In case of doubt contact the manufacturer. Keep these installation instructions with the appliance.

## 1.8 Service and technical support

For information about specific adjustments, installation, maintenance and repair work, please contact:

Intergas Heating Ltd

Unit 2

Easter Park

Worcester Road

Kidderminster

DY11 7AR

Tel: 01527 888000

Fax: 01384 279480

[info@intergasheating.co.uk](mailto:info@intergasheating.co.uk)

[www.intergasheating.co.uk](http://www.intergasheating.co.uk)

## 1.9 Product identification

You will find the appliance data on the data plate on the underside of the appliance.

- A. Model
- B. G.C. registration number
- C. Heat input (net) [kW]
- D. Heat output CH [kW]
- E. Appliance category
- F. Gas type
- G. Gas supply pressure [mbar]
- H. NOx class
- I. Appliance type
- J. Maximum CH pressure [bar]
- K. Maximum Flow temperature [°C]
- L. Electrical supply
- M. Protection
- N. PIN
- O. Serial number
- P. Production year

### Compact HRE \*\* OV

No:

Anno:

#### Condensing boiler

Type	C13,C33,C43,C53,C63,C83	
NOx classe	5	
PIN	0063 BT 3576	
G.C.	41-291-04	

**GB, IE**                      **G20 - 20mbar**                      **II2H3P**

 Qn (Hi)	** - **	kW
Pn	** - **	kW
PMS	3	bar
Tmax	90	°C



~230V-50Hz, 80W, IP44

**INTERGAS®**

Intergas Heating Ltd  
Building 94, Bay 1  
Vantage Point, The Pensnett, Kingswinford  
DY6 7FS, United Kingdom

**CE**  
0063

Made in Holland

## 2 SAFETY REGULATIONS

The manufacturer Intergas Heating Ltd accepts no liability whatsoever for damage or injury caused by failure to adhere (strictly) to the safety regulations and instructions, or carelessness during installation of the Intergas Compact HRE OV High Efficiency wall mounted gas fired boiler and any associated accessories.

### 2.1 General

It is law that all gas appliances are installed by a Gas Safe registered competent engineer and in accordance with the following recommendations:

- Current Gas Safety (Installation and Use) Regulations
- All current building regulations
- Building Standards (Scotland) Consolidated
- This appliance must be installed in accordance with the Gas (Safety and Use) Regulations, current Building Regulations, Building Standards (Scotland), I.S.813 Installation of Gas Appliances (Ireland), IEE Wiring Regulations (BS 7671), Health and Safety Document No. 635 (Electricity at Work Regulations) and Local Water Authority Bye Laws
- UK Water Regulations and Bye Laws
- Health & Safety



### 2.2 The installation

The installation must comply with the following British Standards codes of practice:

- BS 5440: Flues and Ventilation for gas appliances of rated input not exceeding 70kW (Part 1 Flues)
- BS 5440: Flues and Ventilation for gas appliances of rated input not exceeding 70kW (Part 2 Air Supply)
- BS 5546: 2000 Installation of gas hot water supplies for domestic purposes.
- BS 5549: 1990 Forced circulation hot water systems
- BS 6700: 1997 Design, Installation, testing and maintenance of services supplying hot water
- BS 6798: 2000 Specification for installation of gas fired hot water boilers of rated input not exceeding 70kW
- BS 6891: 1998 Installation of low pressure gas pipe-work installations up to 35mm (RI)
- BS 7593: 1992 Code of practice for treatment of water in heating systems
- BS 7671: 2001 Requirements for electrical installations, IEE Wiring regulations



#### Reference should also be made to:

- Guide to condensing boiler installation assessment procedures for dwellings
- The institute of Gas Engineers document IGE/UP/7 for timber frame dwellings

### 2.3 Approvals

Natural Gas

Intergas Compact HRE OV Pre-mix Condensing Open Vent Boiler

British Gas Service Listing:

Compact HRE 30 OV	G.C.N. 41-291-06
Compact HRE 24 OV	G.C.N. 41-291-05
Compact HRE 18 OV	G.C.N. 41-291-04

Notified /Body

Gastec	0063PT3576	Directive 90/396/EEC
		Directive 92/42/EEC

**CAUTION**

The Intergas Compact HRE OV are intended for domestic use only (special conditions apply for commercial use. Please contact Intergas Heating for additional information)

The Intergas Compact HRE OV range of central heating boilers are manufactured from high quality materials and designed for reliability and optimum performance.

Intergas is committed to the continual development of their appliances and reserves the right to make changes without notification to ensure their customers benefit from the latest advances in combustion technology and energy conservation.

**2.4 Technical data**

Appliance category	C13; C33; C43; C53; C83
Gas supply pressure	20 mbar -G20 ; 37 mbar – G31
Gas Category	II2H3P

<b>Technical data Compact HRE OV</b>	<b>18</b>	<b>24</b>	<b>30</b>
--------------------------------------	-----------	-----------	-----------

SEDBUK Rating	A	A	A
Gas Council number	G.C. 41-291-04	G.C. 41-291-05	G.C. 41-291-06

CH				
Nom. Input rating (lower value)*	kW	5.6 – 18.7	7.1 – 23.7	7.6 – 27.0
Rated power*	kW	6.1 – 18.2	7.7 – 23.1	8.2 – 26.6
Max. CH-water pressure	Bar	2.5	2.5	2.5
Max. CH water temperature	°C	90	90	90

Other data				
Gas consumption (G20)	m <sup>3</sup> /h	0.58 – 1.94	0.75 – 2.46	0.79 – 2.80
Gas consumption (G31)	m <sup>3</sup> /h	0.22 – 0.74	0.28 – 0.94	0.30 – 1.07
Appliance pressure loss (CH)	mWk	See § 10.5	See § 10.5	See § 10.5
NOx class natural gas		6	6	6
NOx class LPG		6	6	6
Flue gas mass flow	g/s	10,3	13,1	15,3
Maximum back-pressure	Pa	75	75	75

Electrical data				
Mains power	V	230	230	230
Safety class	IP	IP44	IP44	IP44
Power consumption : full load	W	130	130	130
Power consumption: partial load	W	40	40	40
Power consumption: standby	W	2	2	2

Boiler dimensions and weight				
Height	mm	590	650	710
Width	mm	450	450	450
Depth	mm	240	240	240
Weight	kg	30	33	36

We have a policy for continual improvement and development, therefore we reserve the right to change specifications without prior notice.

2.5 Product FICHe according to CELEX-32013R0811, ANNEX iV

Supplier			Intergas Heating Ltd Unit 2 Easter Park Worcester Road Kidderminster DY11 7AR		
Type designation	Symbol	Unit	Compact HRE		
			18	24	30
Seasonal space heating energy efficiency class	-	-	A	A	A
Heat rated output (power)	P <sub>rated</sub>	kW	18	23	27
Seasonal space heating energy efficiency	$\eta_s$	%	93	93	93
Annual energy consumption	Q <sub>HE</sub>	GJ	55	69	80
Sound power level	L <sub>WA</sub>	dB	45	45	50



**CAUTION**

- Please read all instructions before fitting this appliance.
- This appliance is not intended for use of persons (including children) with diminished physical, sensory or mental ability, or lack of experience and knowledge, unless supervised by, or instruction about the use of the appliance by a person who is responsible for their safety.
- The appliance and installation should every year be inspected by an qualified installer and cleaned when necessary. See annual cleaning § 12.
- The appliance can be cleaned with a damp cloth. Don't use aggressive or abrasive cleaning- or solvent products.



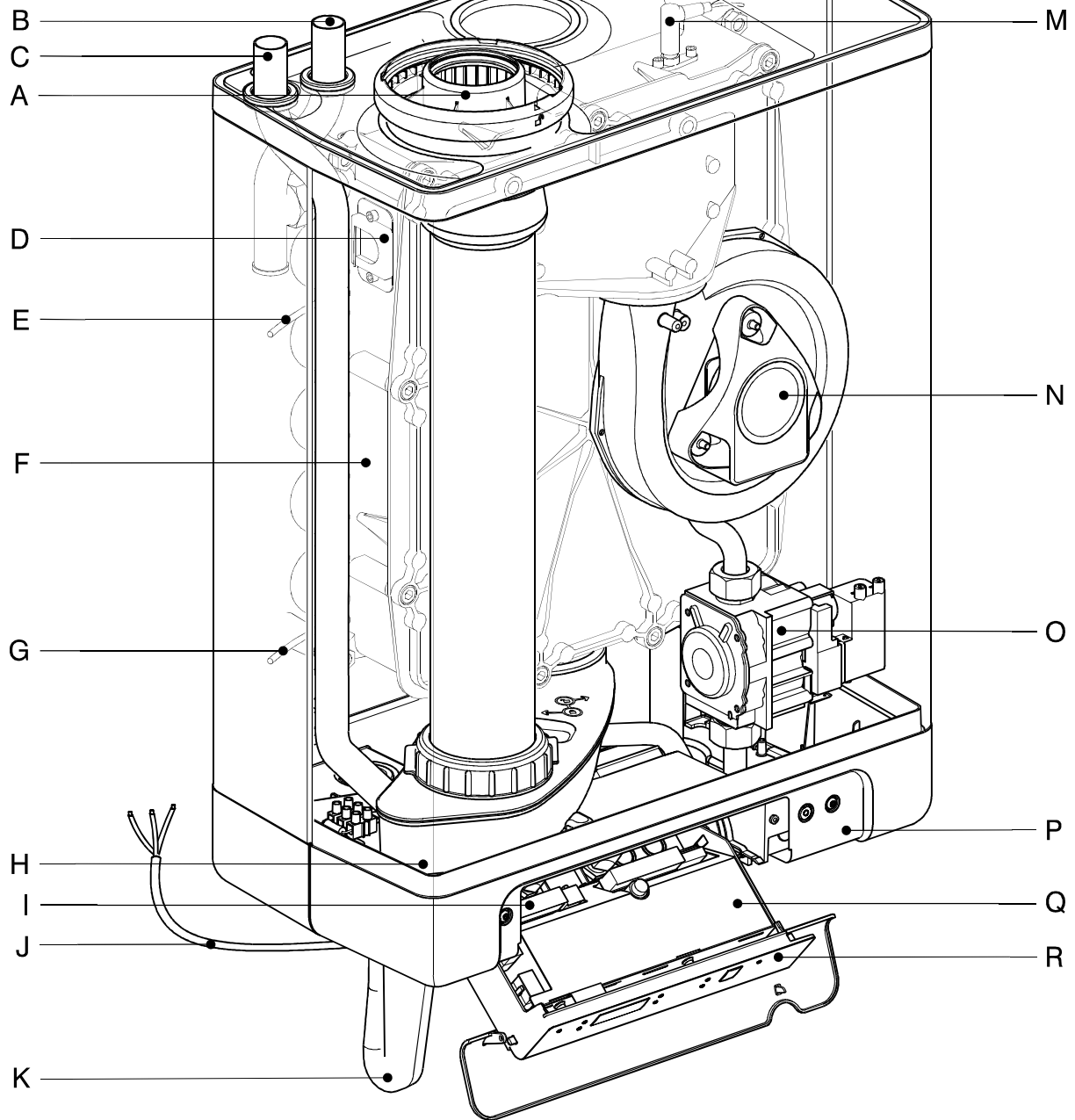

- |    |  |    |   |
|----|--|----|---|
| A. | Flue adapter (only to be used in combination with the accompanying elbow in flue sets) | J. | Mains lead 230 V AC without plug (stripped) |
| B. | Flow CH  | K. | Condensate trap                             |
| C. | Return CH  | M. | Ionisation / Ignition electrode             |
| D. | Sight glass  | N. | Fan   |
| E. | Sensor S1  | O. | Gas valve                                   |
| F. | Heat exchanger   | P. | Position of data plate                      |
| G. | Sensor S2  | Q. | Boiler controller                           |
| H. | Condensate drain pan   | R. | Operating panel and read-out                |
| I. | Connection block / terminal strip X4   |    |   |

## 3 GENERAL BOILER INFORMATION

### 3.1 General

The Intergas Compact HRE OV wall mounted, gas fired boiler is suitable for use in open vent systems with a heating system feed tank. The appliance is designed to transfer heat to the water circuit in a CH system and when an indirectly heated domestic hot water (DHW) storage cylinder is installed, apply heat to the DHW installation.

The air supply and combustion gas flue connection is as standard prepared for a concentric 60/100 flue system. The Intergas Compact HRE OV wall mounted gas fired boiler carries the CE rating and IP44 electrical protection.

The appliance has been set to natural gas (G20) by the manufacturer as standard.

For usage of LPG (G31) the boiler can be converted by changing the gas restrictor ring. A gas conversion kit can be ordered at Intergas Heating Ltd.

#### Note

*Modification of the boiler can only be done by a qualified competent person.*

### 3.2 Boiler controller

An electronic control unit, consisting of a boiler controller and separate ignition module which is placed on the gas valve, provides direct burner ignition and flame supervision along with continuous modulation of the burner's gas supply.

### 3.3 Parameter list

All boiler adjustments are accessible through the parameter list in the software.

### 3.4 Heat transfer

Heat transfer to the boiler's heating circuit is obtained via a primary, gas to water heat exchanger within a hermetically sealed combustion chamber. A modulated speed fan blows the gas/air mixture into the combustion chamber and expels the products of combustion to outside air via an associated flue system.

### 3.5 Central heating system

An external pump can be connected on terminal X2/7-8, see chapter 13.

### 3.6 Room temperature control

Room temperature can be controlled by the use of an external room thermostat and thermostatic radiator valves.

#### Note

*Connection of the room thermostat is dependant on the operating voltage of the thermostat.*

### 3.7 Integrated clock

The boiler incorporates an integral clock, which allows the setting of central heating periods (See the User Instructions, 'Operation and display read-out' for details) and the boiler's control panel incorporates an LED display, which indicates the state of operation and fault defect codes. When an external controller is used the integral clock must be set onto c-on (See § 4.4).



## 4 OPERATION

### 4.1 General

The Intergas Compact HRE OV wall mounted, gas fired open vent boiler is a modulating high efficiency boiler. This means that the power is adjusted in line with the desired heat requirement. It is designed to be used in an open vented system with heating system feed tank.

The appliance is equipped with an electronic boiler controller which, each time heat is requested from the heating supply, starts the fan, opens the gas valve, ignites the burner and continuously monitors and controls the flame, depending on the requested output.

### 4.2 Central heating mode

When a heating demand is requested (power is on, the timer and thermostat are calling for heat) the external pump is energised and the boiler will fire automatically. The hot water is now circulated around the central heating system. When the end of the central heating demand is reached (the thermostat reaches temperature or the time clock reaches the end of its set period) the burner will shut down while the pump remains functioning during a preset period of time to dissipate any excess heat from within the boiler's heat-exchanger. After that the boiler will revert to stand-by, waiting to respond to the next heating demand.

### 4.3 Operating modes

A code on the service display of the operating panel indicates the appliance's operating mode.

#### Off

The appliance is out of operation but is supplied with electrical power. No response occurs to calls for DHW or CH. The appliance frost protection is active. This means that the external pump operates and the exchanger is heated up if the temperature of the water present in it falls too far.

If the frost protection is actuated, code  is displayed (heating the exchanger).

In this operating mode the pressure in the CH installation (in Bar) can also be read on the temperature display.

#### Waiting mode

The LED at the  button is lit and possibly one of the LEDs for the DHW comfort function. The appliance is ready to respond to a request for CH or DHW.

#### Pump overrun of CH

After the end of CH operation the external pump continues to run. The running time is factory set at the value in accordance with § 10.3. This setting can be changed.

In addition, the pump runs automatically for 10 seconds once every 24 hours in order to prevent seizing. This automatic switching on of the pump occurs at the time of the last call for heat. To change the time, the room thermostat setting should be increased briefly at the desired time.

#### Boiler shutdown when required temperature reached

The boiler controller can temporarily shut down the request for heat. The burner is then stopped. Shutdown occurs because the requested temperature has been reached. When the temperature has fallen sufficiently and the anti cycle time has passed the shutdown is cancelled.

#### Self-test

The connected sensors are checked regularly by the boiler controller. During the check the boiler controller does not perform any other tasks.

#### Ventilation

When the appliance is started the fan is first brought to starting speed. When the starting speed has been reached the burner is lit. Code  is also visible when post-ventilation is taking place after the burner has stopped.

## **4** Ignition

When the fan has reached the starting speed, the burner is ignited by means of electrical sparks. During ignition the code **4** is visible. If the burner does not ignite, a new ignition attempt occurs after approximately 15 seconds. If after 4 ignition attempts the burner is not yet burning, the boiler controller goes into fault mode (See § 11.1).

## **5** CH operation

An on/off thermostat, an OpenTherm thermostat, an external sensor or a combination of the latter can be connected to the boiler controller.

When a request for heat is received from a thermostat, the fan is started (code **3**), followed by ignition (code **4**) and CH operating mode (code **5**).

During CH operation the fan speed and hence the appliance power are controlled by the boiler controller so that the CH water temperature reaches the desired CH supply temperature.

If an on/off thermostat is connected, this is the CH supply temperature set on the display. In the case of an OpenTherm thermostat the desired CH supply temperature is determined by the thermostat. In the case of an external sensor the desired CH supply temperature is determined by the heating line programmed in the boiler controller. For the latter two, however, the maximum is the temperature set on the display.

During CH operation the requested CH supply temperature is indicated on the operating panel.

The CH supply temperature is set to 75°C and can be adjusted between 30°C and 80°C. If, under circumstances a flow temperature is needed up to 90°C the value of parameter 5. (max. value for flow temperature in display) needs to be adjusted.

### **4.4 Clock function**

The boiler is equipped with a digital clock and offers the possibility to program 4 points in time to switch from CH off or CH on.

During the "clock active" periods the boiler will respond on CH demands from the room thermostat. During the "clock inactive" periods the boiler will not respond on CH demands.

When an external controller is used the internal clock must be set onto c-on.

Additionally the following special modes can be chosen:

1. t-on (temporary on).  
The boiler will respond to every CH demand from the room thermostat or external controls until the next switch moment.
2. c-on (continuous on).  
The boiler will respond to every CH demand from the room thermostat or external controls without any time limit.
3. OFF.  
The boiler will not respond to any CH demand from the room thermostat or external controls..

#### **Note**

*For setting and adjusting the clock see § 9.3 Setting and adjusting the clock functions.*



### **4.5 PC interface**

The boiler controller is equipped with an interface for a PC, which can be connected by means of a special cable and associated Intergas Diagnostic Software (IDS). This facility allows the behaviour of the boiler controller, the appliance and the heating installation to be monitored over a longer period.

#### 4.6 Test programs

The boiler controller has a facility for placing the appliance in test mode. Activation of a test program will result in the appliance starting operation at a fixed fan speed, without the control functions being actuated. The safety functions do remain active. The test program is ended by pressing the **+** and **-** simultaneously or will end automatically after 10 minutes.

#### Test programs

Program description	Button combinations	Display reading
Burner on at minimum power	 and <b>-</b>	"L"
Burner on with maximum CH power setting (See § 10.3, parameter 3)	 and <b>+</b> (1x)	"h"
Burner on with maximum DHW power (See § 10.3, parameter 4)	 and <b>+</b> (2x)	"H"
Switch off test program	<b>+</b> and <b>-</b>	Actual situation

#### Addition readings :

During test mode the following data can be read :

- By pressing the **-** button continuously in the display the CH water pressure is shown.
- By pressing the **-** button continuously in the display the ionisation current is shown.

#### 4.7 Frost protection



##### FROST PROTECTION

To prevent freezing the appliance is equipped with an internal frost protection. If the heat exchanger temperature falls too low, the burner switches on and the external pump runs until the heat exchanger temperature is sufficient. When the appliance frost protection is activated the symbol code **7** is displayed (pre heating the heat exchanger).

If the installation (or a part of it) is in danger of freezing, an (external) frost thermostat must be fitted to the return line at the coldest location. This must be connected in accordance with the wiring diagram (See § 8.2.1).

#### Note





If the appliance is out of operation ( **-** on the service display) the appliance 's internal frost protection is still active. However, this means there will be no response to a request for heat from an (external) frost thermostat.

## 5 INSTALLER IMPORTANT POINTS

### **Please read all instructions before fitting this appliance**

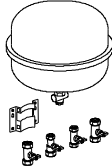
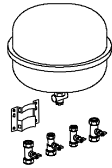

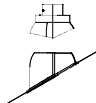
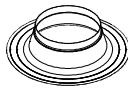

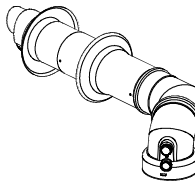
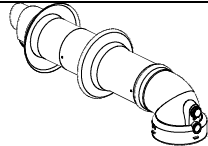
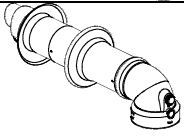
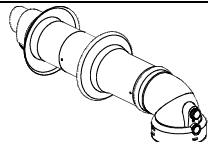

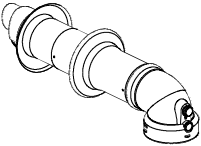
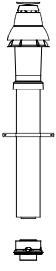
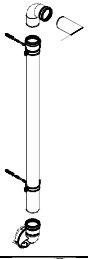
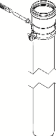





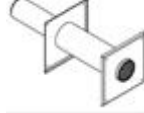

- The installer shall instruct the user on the operation of the boiler, safety devices contained within the boiler and on the location of the filling loop and how to re-pressurise the system if the water pressure falls.
- The installer should hand over the installation and user instructions upon completion with the completed Benchmark Commissioning Checklist.
- The service engineer must complete the service record on the Benchmark Checklist after each service.
- It is required under Gas Safe Regulations for the installation to be notified to and registered with Gas Safe, Intergas and Building Control (Gas Safe Notification).
- Before proceeding to commission the boiler check the gas inlet pressure is 20mbar (NG) or 37mbar for LPG.
- Combustion analysis with a correctly calibrated and certificated analyser is essential for safe commissioning of the boiler.
- A pressure reducing valve set to 3.5 bar must be fitted if supply mains pressure is above 4 bar.
- In hard water areas where the PH is 200ppm or above, appropriate protection actions must be taken in accordance with BS 7593 in line with building regulations Part L. (See T&C)
- The user should be instructed to keep the instructions in a safe place for servicing and future reference.
- It is important to keep the boiler clear of dust during the installation. In particular, do not allow debris to enter the flue connection at the top.
- Before fitting the boiler ensure that the pipe work that you are installing is connected to the appropriate connections on the boiler.  
It is important to thoroughly flush the water circuits after isolating the boiler, in order to remove any fluxes, debris and all cleansing chemicals from the system. This should be done particularly where boilers are being fitted to existing radiator circuits (please refer to current Standard Codes of Practice).
- Intergas recommend water treatment in accordance with the Benchmark Guidance on Water Treatment in Central Heating Systems, we recommend the use of FERNOX, SENTINEL or ADEY inhibitors. It is most important that correct concentration of water treatment is maintained for the life of the boiler, a water sample is required on installation and to be verified by the aforementioned manufacturers should we attend a warranty call a water sample may be required to keep the warranty valid. (BS 7593:2006)
- This boiler has been factory set but adjustment may be required to the heating input in order to match the individual heating demand. This can be done by changing parameter 3 (= max. power CH) or parameter 4 (= max. power domestic water).
- Please do not use the pressure relief valve as a means of flushing the system.
- Remember that after hot water draw of a possible delay may occur before the heating system will fire up.
- All fluxes, residues and cleaner must be flushed from pipe-work and radiators prior to commissioning.
- External expansion vessels are best connected water side downwards to allow correct draining/cleaning of system and to prolong the life of the vessel diaphragm.
- Note: an anti-cycle delay time can be set up to a maximum of 15 minutes by adjusting parameter P as described in § 10.3.
- If you experience any problems please refer to the installation and commissioning guidelines within the boiler instruction manual. If necessary, please contact Intergas Heating Ltd (See § 1.8).
- Remember it is a requirement to complete the Benchmark code of practice logbook before leaving the installation. You are also required to register the boiler through the Gas Safe registration scheme and with Intergas.

## 6 ACCESSORIES

Description	Article number	
Pipe cover set (incl. mounting material)	093217	
Outside sensor	203207	
DHW storage cylinder sensor	065117	
Diverter valve 230 V	092647	
Sampling cap	847000	
Robo kit 8 ltr.	090100	
Robo kit 12 ltr.	090000	
Deflector kit	081295	
Weather slate (steep roof)	087910	
Weather slate (flat roof)	087372	
Extension L = 100 incl. wall bracket	082975	
Extension L = 500 incl. wall bracket	082979	
<b>Horizontal telescopic offset wall terminal</b> <i>Only to be used in combination with the base adapter on the boiler</i>	081298	
<b>Horizontal straight wall terminal extended</b> <i>Only to be used in combination with the base adapter on the boiler</i>	082980	
<b>Horizontal telescopic wall terminal</b> <i>Only to be used in combination with the base adapter on the boiler</i>	081297	
<b>Horizontal wall terminal, thick wall WL=1000</b> <i>Only to be used in combination with the base adapter on the boiler</i>	082969	

<p><b>Horizontal wall terminal, thick wall WL=2000</b>  <i>Only to be used in combination with the base adapter on the boiler</i></p>	082986	
<p><b>Vertical roof terminal</b>  <i>(incl. boiler adapter 60/100)</i></p>	082973	
<p><b>Plume management kit</b></p>	081294	
<p><b>Extension L = 100 incl. wall bracket (for plume management kit)</b></p>	081286	



Description	Article number	
Weather Slate Steep 80/125 25°- 45°	087909	
Weather Slate Flat 80/125	075333	
Horizontal Wall Terminal 80/125	076355	
Wall Terminal 80/80	187921	
Roof terminal 80/80 PP	086883	
High Level Horizontal Plume kit Terminal 80/125	081738	
Air Terminal 80	082856	
Air Cover Terminal 80/125	075438	
Flue Extension 80 x 250mm inc Bracket	453973	
Flue Extension 80 x 500mm inc Bracket	453975	
Flue Extension 80 x 1000mm inc Bracket	453977	
Flue Extension 80 x 2000mm inc Bracket	453979	
Elbow 80 90° (2pcs) inc Brackets	453992	
Elbow 80 45° (2pcs) inc Brackets	453990	
Wall Bracket 80	452203	
Boiler Flue Adapter 80 mm	090767	

# 7 INSTALLATION

## 7.1 Overall dimensions

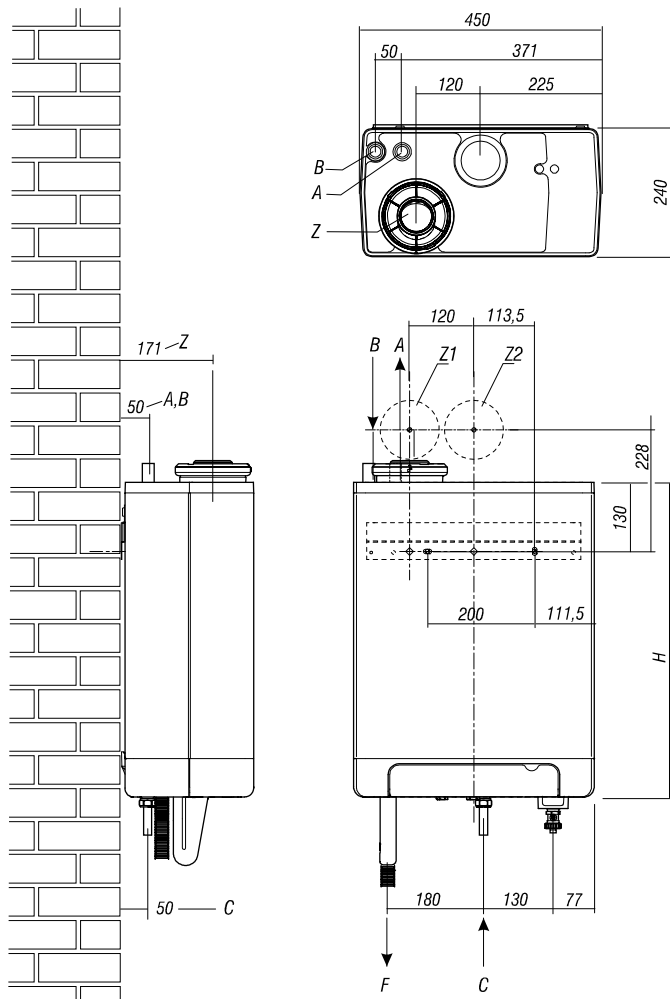

A =	Supply CH	Ø22
B =	Return CH	Ø22
C =	Gas	½"
F =	Condensate drain	Ø25 (flexible)
G =	Drain PRV	Ø15
H =	710	Compact HRE OV 30
H =	650	Compact HRE OV 24
H =	590	Compact HRE OV 18
Z1 =	Standard flue pipe	Ø60/100 (concentric)
Z2 =	Standard off-set flue pipe	Ø60/100 (concentric) pipe

## 7.2 Installation location

- If the boiler is to be installed in any room or compartment, it does not require any purpose made ventilation for combustion air. If sited in a room containing a bath or shower then particular reference is drawn to the current I.E.E. Wiring Regulations, local Building Regulations or any other local regulations currently in service.
- The boiler is not suitable for external installation unless protected by a purpose made building such as a boiler house.
- The following clearances are recommended for installation purposes: 200mm above, 300mm below and 10mm at each side. 500mm is required at the front but this may be realized by opening a cupboard door.
- Flammable fluids and materials must be stored at least 1m away from the boiler
- The wall on which the boiler is mounted must be sufficiently strong to support the weight of the boiler.

### 7.2.1 Installing in a kitchen cupboard

The appliance can be installed between two kitchen cabinets or in a cabinet. Ensure sufficient ventilation at top and bottom. When installed in a cabinet, ventilation openings of at least 50 cm<sup>2</sup> must be created at the top and bottom of the appliance to ensure free flow of air.

### 7.2.2 Removing cover plate and front panel

For various work on the appliance the cover plate and front panel should be removed from the appliance. Proceed as follows:

- If cover plate (A), is used, remove to the front.
- Unscrew the two screws (1) behind the appliance display window.
- Pull the bottom of the front panel (2) forwards.

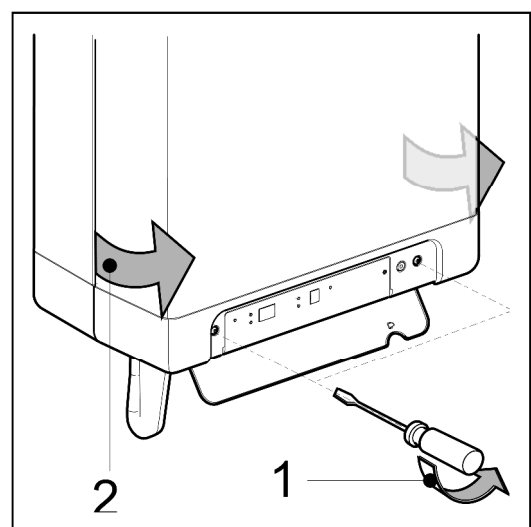
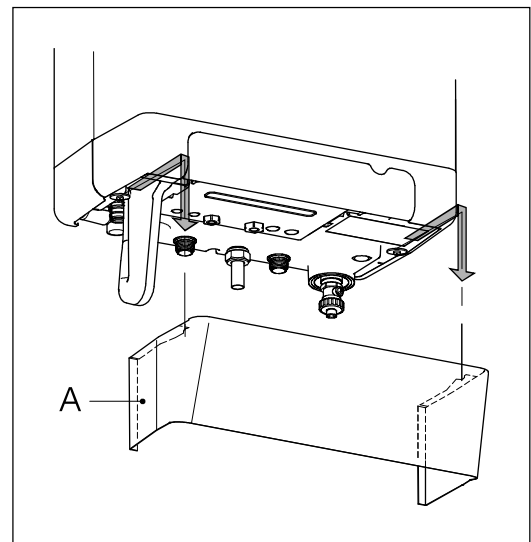
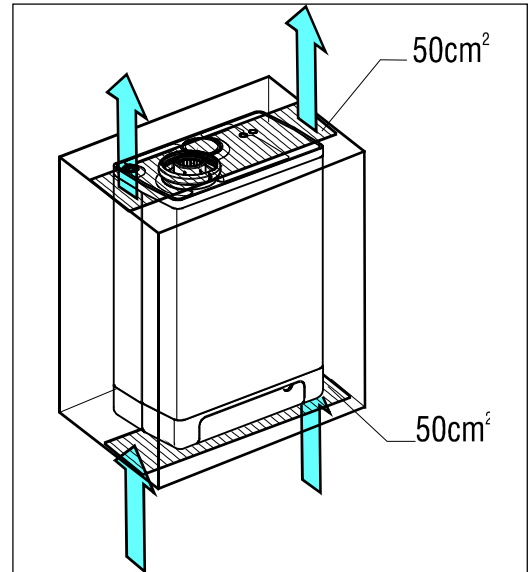

### 7.3 Installing the appliance

1. Unpack the appliance.
2. Check the contents of the packaging. It consists of:
  - Appliance (A)
  - Wall mounting strip (B)
  - Condensate trap (C)
  - Pressure fitting 22 mm (2 pcs)
  - Gas isolation valve 15/22 mm compression
  - Installation instructions
  - Operating instructions
  - Warranty card
  - Template for wall mounting
3. Check the appliance for possible damage: report damage immediately to the supplier.
4. If the wall mounting strip is secured to the wall then slide the boiler down until latched.
5. Connect the flue and return pipe to the installation using the enclosed compression fittings 22 mm.
6. Connect the gas isolation valve to the gas pipe.
7. Fit the flexible tube to the condensate trap outlet.
8. Fill the condensate trap with water and slide it as far as possible upwards on to the condensate drain connector below the appliance.
9. Connect the flexible tube from the condensate trap to the drain via an open connection. The condensate discharge system must be made of plastic, no other materials may be used. The discharge duct must have a minimum gradient of 5 – 20 mm/m. Condensate discharge via the gutter is not allowed given the risk of frost and the possible damage to materials.
10. Fit the flue.



#### CAUTION

Always fill the condensate trap with water and place it on the boiler before powering up the boiler.

Not placing or filling up the condensate trap may cause flue gases to come into the installation room and can lead to dangerous situations!

In order to place the condensate trap the front cover must be pulled forward or removed entirely.



#### Note

It is recommended that any external condensate pipe is insulated and increased to 32mm diameter in order to prevent the condensate from freezing.

#### 7.3.1 Fitting the cover plate

Hang the flanged upper edge of the cover plate on the washers under the base of the appliance and slide the cover plate as far as possible towards the rear.

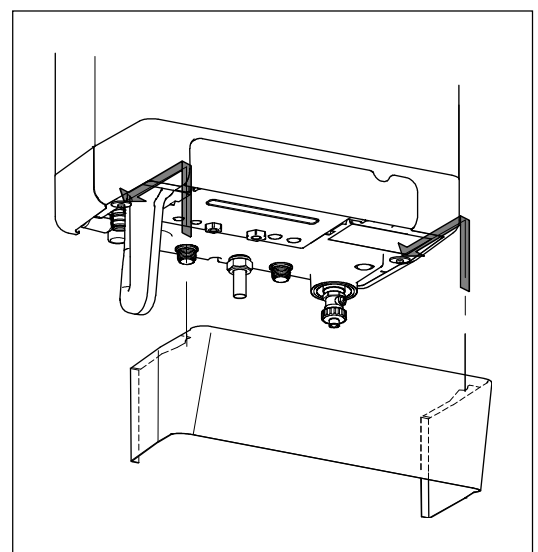
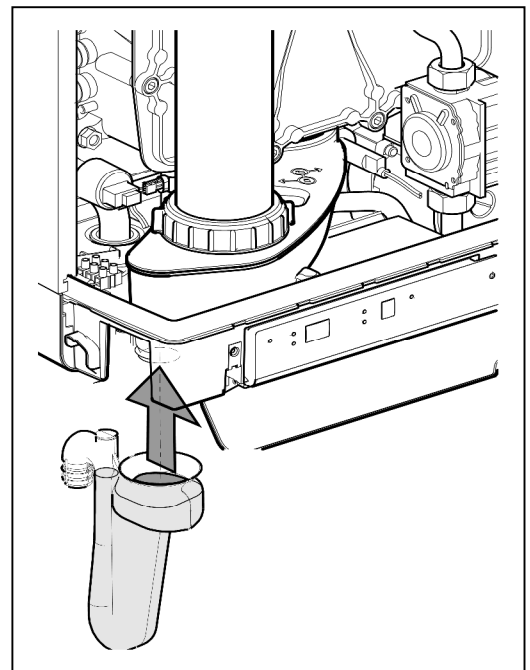
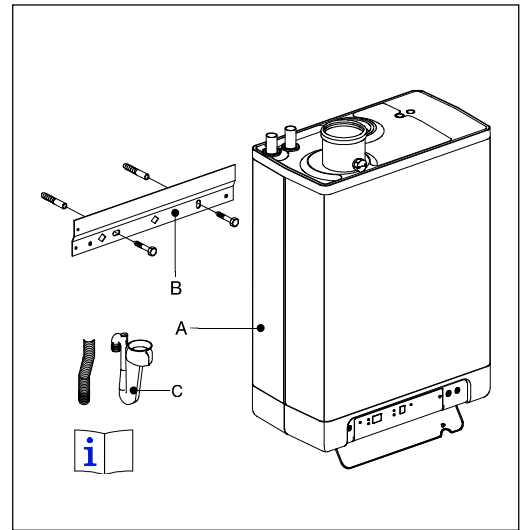

## 8 CONNECTION

### 8.1 Connecting CH installation

1. Flush the CH system thoroughly to clean.
2. Connect the flue and return pipe to the installation using the enclosed press fittings 22 mm.
3. All pipes must be fitted unstressed in order to prevent the pipes from ticking. Make sure the compression fittings are tightened thoroughly to prevent leakage.



#### CAUTION

**Under no circumstances is it allowed to connect the flow and return of the boiler to the installation by means of a soldered connection.**

**Always use the enclosed compression fittings !**

#### 8.1.1 The CH system should be equipped with:

- A drain tap at the lowest point(s) of the installation.
- A heating system feed tank.

#### 8.1.2 Thermostatic radiator valves

If all radiators are equipped with thermostatic or radiator valves, an auto bypass must be fitted in order to guarantee minimum water circulation. The auto bypass must be at a distance of at least 20 ft from the appliance in order to prevent overheating of the appliance.

### 8.2 Gas connection

1. Fit the enclosed gas isolation valve on the gas pipe under the boiler.
2. Connect the appliance to the gas supply.
3. Check the gas carrying parts for leakage at a maximum pressure of 500 mm H<sub>2</sub>O.

### 8.3 Electrical connection



#### CAUTION

A fused spur or an unswitched socket must be located no more than 1 metre from the appliance.

Correct earthing in accordance to applicable regulations is obligatory for the safety and functionality of the boiler.



For installation in damp rooms a fixed connection is obligatory.

When working on the electrical circuit always isolate the electric supply.

1. Slide the cover plate (A) (if present) to the front to remove.
2. Open the display cover and unscrew both screws to remove the front cover.
3. Pull the boiler controller unit forwards; the boiler controller will tip downwards to provide access.
4. Consult sections § 8.3.1 and chapter 13 for making the connections.
5. After making the desired connections plug the appliance into an earthed wall socket.

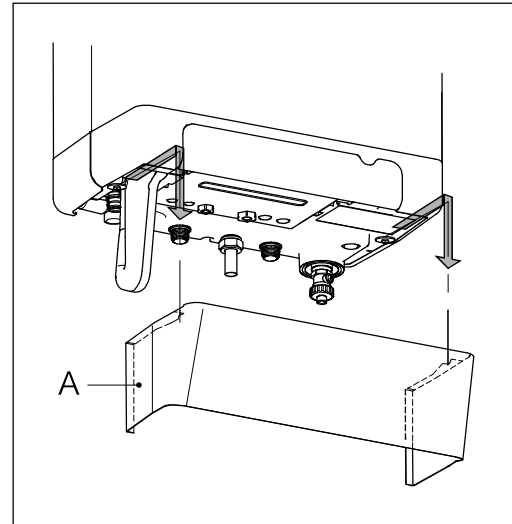

#### 8.3.1 Electrical connections

Temperature control	Connector X4	Notes
Room thermostat	6 – 7	Voltage free. <b>Remove link 6-7</b>
Outside temperature sensor	8 – 9	-
Frost protection thermostat	6 – 7	Parallel to room thermostat
Open Therm (OT)	11 – 12	<b>Remove link 6-7</b>

Temperature control	Connector X2	Notes
Room thermostat 230 V or external control 230 V.	1 – 3	<b>Remove link 6 – 7 (connector X4)</b>
Frost thermostat 230 V	1 – 3	<b>Remove link 6 – 7 (connector X4)</b>

Switch live from S-plan or Y-plan onto connector X2, no.1.  
See chapter 13.3 and 13.4 for complete electrical schedules.

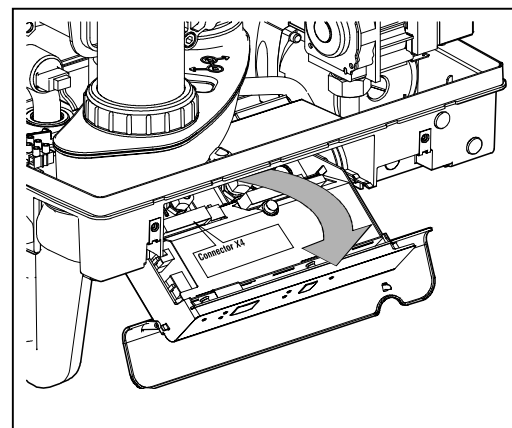
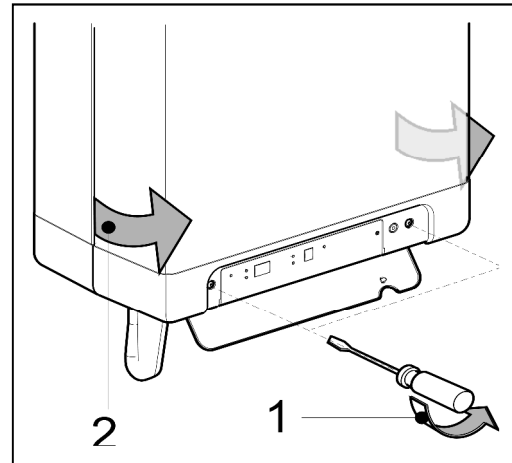

### 8.3.2 On / off room thermostat (low voltage)

To be connected to contacts 6 and 7 of connector X4.  
This is a 24 volt connection and no mains power must be applied to these terminals.  
See chapter 13, electrical diagram.



#### Note

***When a 24 volt thermostat is connected to contacts 6 and 7, the loop in 6 – 7 must be removed.***

1. The on/off room thermostat has to be connected to the contacts 6 and 7 of connector X4.
2. Adjust the feedback resistance of the room thermostat to 0.1 A. In case of doubt measure
3. the current and adjust this accordingly.
4. The allowed maximum electrical resistance of the room thermostat and wiring is 15 Ohm.

### 8.3.3 Open Therm room thermostat

Open therm is a protocol that enables the boiler and the room thermostat to communicate. Based on the information from the room thermostat the flow temperature of the boiler is adjusted to the most optimal value.

The Open Therm (OT) room thermostat has to be connected to the contacts 11 and 12 of connector X4 (see chapter 13, electrical diagram).



#### CAUTION

**Connecting the Open Therm room thermostat to other contacts than 11 – 12 may damage the room thermostat !**



#### NOTE

***When an Open Therm thermostat is connected to contacts 11 and 12, the loop in 6 – 7 must be removed.***

### 8.3.4 Outside temperature sensor

The appliance is equipped with a connection for an outside temperature sensor. The outside temperature sensor can be used in combination with an on/off room thermostat or an OpenTherm thermostat.

Connect the outside temperature sensor (See § 8.3.1).

For the heating line setting, see weather-dependent regulation (See § 10.6).



#### Warning High Voltage

**Isolate the appliance from the electrical supply before connecting the thermostat.**

### 8.3.5 230 volt room thermostat

To be connected to contacts 1 and 3 of connector X2.  
See electrical diagram.

### 8.3.6 S and Y zone plans

Any combination of external controls for time /temperature and heating of external DHW cylinders or CH zones can be connected to the boiler.

All controls/ zones should be connected in an external wiring centre and a switched live connected to 1 on X2. Set in-built timer to C-ON.



#### NOTE

***When a 230V thermostat is connected, link in 6 - 7 of connector X4 must be removed***

## 8.4 Condensate disposal

The appliance is provided with a 25 mm flexible pipe from its condensate trap. Connect the flexible tube from the condensate trap to the drain via an open connection.



### CAUTION

**Always fill the condensate trap with water and place it on the boiler before powering up the boiler.**

**Not placing or filling up the condensate trap may cause flue gases to come into the installation room and can lead to dangerous situations!**

**In order to place the condensate trap the front cover must be pulled forward or removed entirely.**



The condensate discharge system, pipework and fittings must be made of plastic. No other materials may be used. The discharge duct must have a minimum gradient of 5 – 20 mm/m throughout its length. Condensate discharge via the gutter is not allowed given the risk of frost and the possible damage to materials

- A. Internal stack pipe (see diagram)
- B. Gully
- C. Condensate discharge from boiler
- D. Servicable waste trap
- E. 5 – 20 mm/meter
- F. > 100 mm
- G. > 110 mm
- H. > 450 mm

If an externally-run condensate drainage pipe is used the following measures should be adopted to prevent freezing:

- the pipe should be run internally as far as possible before going externally, the pipe diameter should be increased to a minimum of 30mm ID (typically 32mm OD) before it passes through the wall
- the external run should be kept as short as possible, taking the most vertical route possible to the discharge point, with no horizontal sections in which condensate might collect
- the external pipe should be insulated using suitable waterproof and weatherproof insulation ("Class O" pipe insulation is suitable for this purpose)
- the use of fittings, elbows etc should be kept to a minimum and any internal "burrs" on cut pipework should be removed so that the internal pipe section is as smooth as possible.

For more information about preventive measures against freezing please visit the HHIC website <http://www.centralheating.co.uk/checklists/frozen-condensate-pipes>.

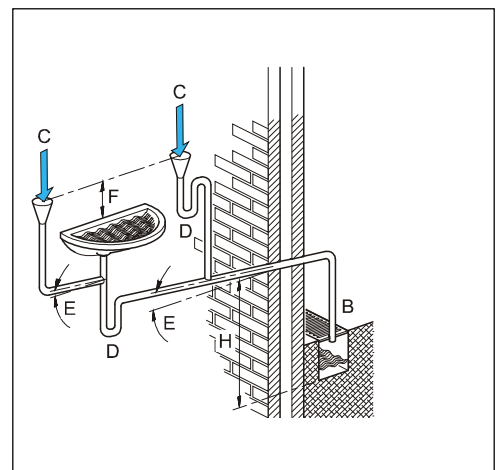
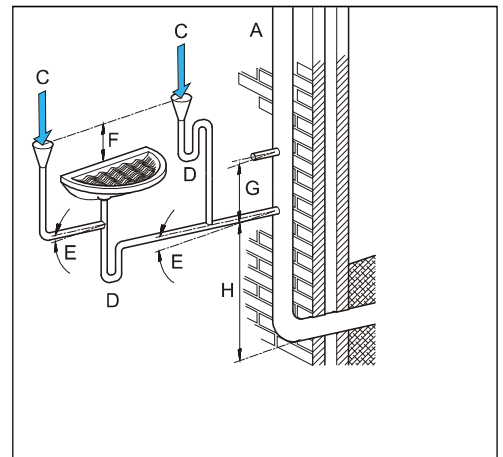



## 8.5 Flue system

### General

- The boiler is prepared to be connected to a concentric flue system 60/100.
- The flue system must be connected to the flue adapter of the boiler.  
The internal seals ensure the air tightness of the connection.
- By replacing the standard adapter for a flue adapter 80mm and removing the plastic cap from the air inlet in the top of the boiler, the boiler can be made suitable for connecting to a 80/80 twin flue system

### Explanation flue system category

Category	Explanation
C13	The terminal is located in the façade; the inlet for the air supply duct is located in the same pressure area as the terminal. Example: combined wall terminal
C33	The terminal is located above the roof; the inlet for the air supply duct is located in the same pressure area as the terminal of the flue piping.
C53	Closed unit, connected to separate air supply duct and flue pipes, terminated in various pressure zones.

### Draft, materials and insulation

Flue type	Diameter	Material
Concentric	60/100	Aluminium, Stainless steel or PP (T120)
Air inlet	ø 80 mm	According to (local) regulations of the fire department and/or energy supply company. Approved material incl. seals - Aluminium - Plate steel (galvanised) - Stainless steel - Plastic. N.B. Rain water drainage pipes are not allowed
Flue gas	ø 80 mm	- Aluminium in accordance to EN 1856-1 or EN 1856-2 - Plastic in accordance to EN 14471 N.B. Temperature class T120
Insulation	-	10 mm vapour-tight insulation material. Applicable when risk on condensation on the outside is present.

#### 8.5.1 Sealed flue system .

##### Twin flue connection

1. Mount the flue pipe in the flue adapter of the boiler. The integrated seal will secure an air-tight connection.
2. Mount the air inlet pipe in the air inlet opening at the top of the boiler. The integrated seal will secure an air-tight connection.

##### Concentric connection.

1. Mount the concentric flue pipe in the flue adapter of the boiler. The integrated seal will secure an air-tight connection.

### 8.5.1 Flue pipe and air supply

The boiler utilises a special concentric flue adapter which can only be used with the elbow that is part of the horizontal or vertical flue pipes. For the appropriate types see chapter 6 Accessories.

#### Note

**Only use approved Intergas flue products with this boiler, which can be sourced from the supplier of your boiler or Intergas stockist**

### 8.5.2 Flue pipe position

	Terminal Position	Min. distance
A	Directly below an open able window or other opening e.g. air brick	300 mm
B	Below gutters, soil pipes or drain pipes can be reduced to 25mm, as long as the flue terminal is extended to clear any overhang. External flue joints must be sealed with suitable silicon seal.	25 mm
C	Below eaves	200 mm
D	Below balconies or car front roofs	200 mm
E	From vertical drain pipes and soil pip	150 mm
F	From internal or external corners	300 mm
G	Above ground, roof or balcony level, Terminal guards must be fitted if less than 2 metres from the ground.	300 mm
H	From a surface facing a terminal	600 mm
I	From a terminal discharging towards another terminal	1200 mm
J	From an opening in a car port (e.g. door, window) into a dwelling	1200 mm
K	Vertically from a terminal on the same wall	1500 mm
L	Horizontally from a terminal on the same wall	300 mm
M	Above an opening, air brick, opening windows, etc.	300 mm
N	Horizontally to an opening, air brick, opening windows, etc.	300 mm
P	Above roof level (to base of terminal)	300 mm
Q	From adjacent wall to flue	300 mm
R	From an adjacent opening window	1000 mm
S	From another roof terminal	600 mm
-	From an external boundary. Note: if the terminal is facing a boundary it is recommended that an anti-plume kit be fitted	600 mm
T	Terminals adjacent to windows or openings on pitched and flat roofs:	
T1	The flue should not penetrate this area	2000 mm
T2		600 mm

#### Note

*Intergas cannot be held responsible for atmospheric conditions when siting flue terminals.*



#### CAUTION

Once the flue has been installed and the appliance commissioned, installer should observe the plume direction. Particular attention should be drawn to plume vapour re-entering the boiler via the air intake. If this occurs, it is highly possible the flue is fitted within a negative pressure area and therefore a plume management kit (PMK) must be fitted.

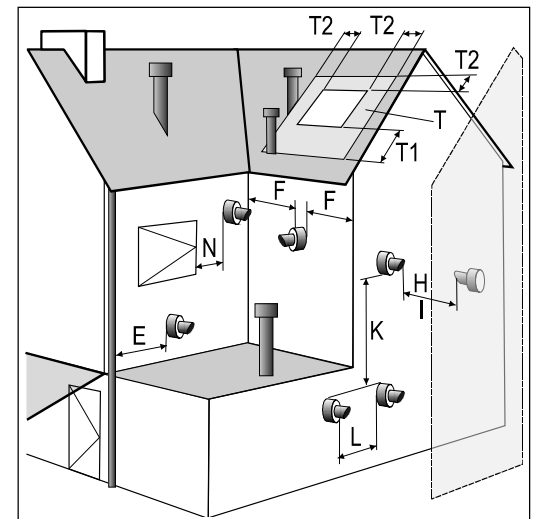
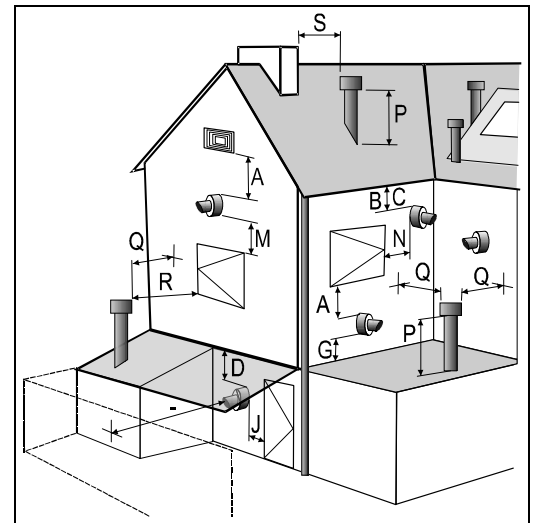

### 8.5.3 Length flue pipe and air inlet

#### Concentric Ø60/100

	C13	C33
Compact HRE 18 OV	10 m	11 m
Compact HRE 24 OV	10 m	10 m
Compact HRE 30 OV	10 m	10 m

#### Twin flue Ø80 (total combined length of combustion air and flue gas)

	C13	C33	C53
Compact HRE 18 OV	100 m	100 m	100 m
Compact HRE 24 OV	85 m	85 m	85 m
Compact HRE 30 OV	80 m	80 m	80 m

#### Replacement lengths

Curve 90°	R/D=1	2 m
Curve 45°	R/D=1	1 m
Knee 90°	R/D=0,5	4 m
Knee 45°	R/D=0,5	2 m

Please contact the supplier for the calculations regarding the resistance of the air inlet and flue pipe and for the maximum wall temperature at the end of the flue pipe.

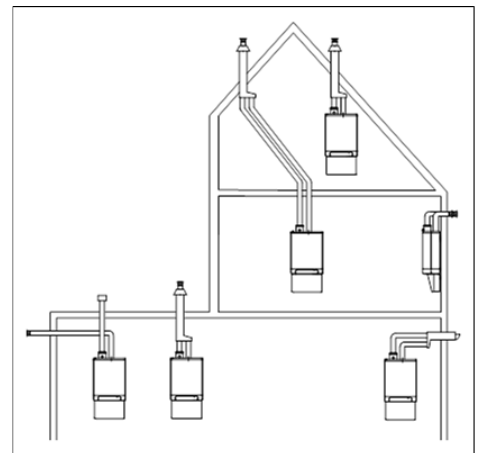
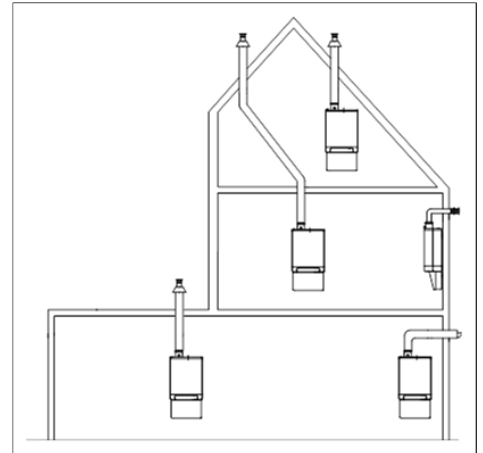

### 8.5.4 Horizontal flue system

The 60/100 mm horizontal flue system may be extended up to a maximum length as mentioned in the table above. No white part of the flue should be visible externally.



#### CAUTION

Only an Intergas approved flue is to be used with this product.

Failure to comply with this requirement will invalidate your guarantee and may lead to a dangerous situation!

The horizontal wall terminal must be installed level as the flue terminal already has a 3 degree rise built in. If the use of flue extensions are needed then they must be fitted with a 3 degree fall back to the boiler and have a bracket fitted every meter to support the flue. Best recommended position of the bracket is just before the joint.

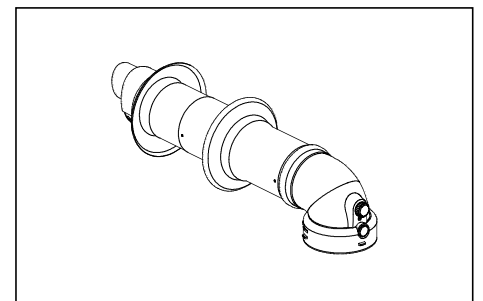

### 8.5.5 Vertical flue system

A vertical 60/100 mm flue kit is also available, which can be extended up to a maximum of 10 metres, excluding the initial boiler connection, using additional components available from the supplier of your boiler or Intergas stockist.

The vertical flue system contains a flue adapter concentric 60/100 to replace the standard adapter on the boiler. You must install the vertical flue adapter with the o-ring to keep the boiler room sealed.

Please note that the terminal is suitable for a flat or pitched roof and only approved Intergas flue products can be used with this boiler.

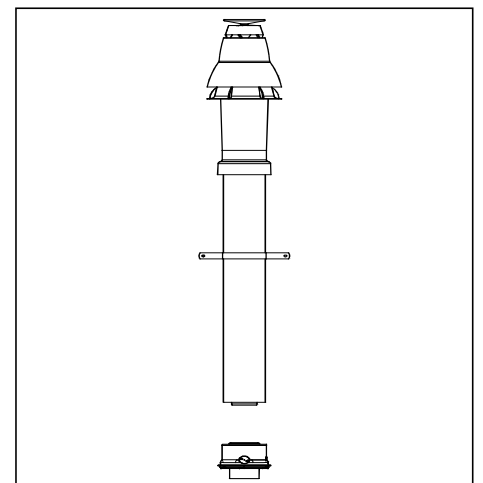

### 8.5.6 Plume management kit

The plume management kit comprises of a flue connector elbow to connect the 500mm vertical condensing tube, which has a horizontal or vertical terminal dependant on your requirements. The maximum length of horizontal flue including the terminal but excluding the initial elbow from the boiler and 1 metre vertical condensing tube is 8 metre.

#### Note

For each additional 90° elbow used the maximum flue length must be reduced by 1.5 metre, whilst the use of 2 x 45° bends warrants a reduction of 2 metre.



#### CAUTION

- Sealing rings should only be moisturized with water before use. Do not use soap or other detergents.
- When installing flues in voids make sure they are connected and fixed correctly. If in an existing situation a visual inspection is not possible the boiler must not be commissioned and remain disconnected from the gas supply until suitable access has been realised.
- Make sure to follow the manufacturer's instructions regarding maximum length of the flue system, the appropriate flue material, correct jointing methods and the maximum distance between flue support.
- Ensure that all joints and seams are gastight and watertight.
- Ensure the flue system has a uniform gradient back to the boiler.

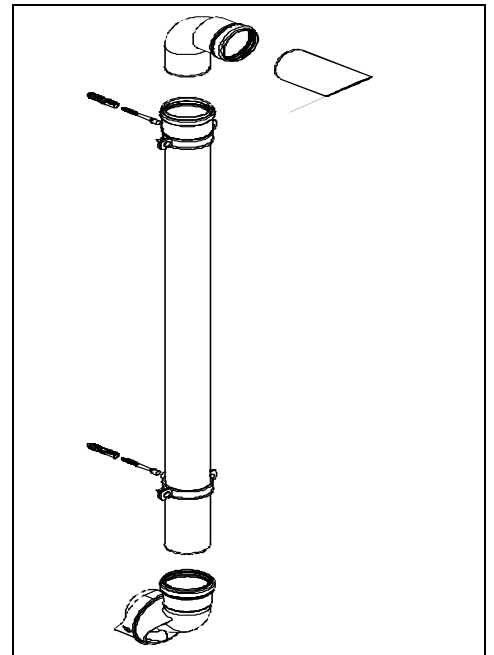

#### Concealed Flue Joints:

##### Acceptable Installations:

**Telescopic Flue & terminal:** The telescopic overlap in Intergas horizontal flue is not considered as a flue joint. The flue section must be adjusted to the correct length then the telescopic joint must be secured and sealed with the screw and tape provided in line with manufacturers instructions. It is acceptable for this secured, sealed overlapping connection to be sited within the building fabric.

##### Non- acceptable Installations

**Flue Extensions & Elbows:** Flue joints between flue extensions & elbows must not be sited within the building fabric. Where necessary flue extensions should be cut to suit to avoid this.

##### Flue Integrity:

The flue should be inspected under its annual service and at the initial commissioning of the appliance to confirm:

- All joints in the flue system are sound and correctly assembled according to manufacturers instructions.
- The flue is continuous without any breaks.
- All flue joints should be visible for visual inspection.
- Checked by means of sampling the air intake at the flue air intake sample point with a calibrated flue gas analyser.
- All voids containing concealed flues should have inspection hatch measuring no less 300mm square. (Ref TB 008Ed3)

### 8.5.7 Flues in voids

The flue system must be connected in accordance with the manufacturers instructions BEFORE firing the boiler.

The term void includes ceiling voids, floor voids, purpose built enclosures, service risers, roof spaces or any other enclosure that will restrict access to inspect the flue.

To allow visual inspection, without reliance on devices such as endoscopes, cameras and mirrors, inspection hatches must be provided along the entire length of the flue.

Hatches must be a minimum of 300mm x 300mm and positioned with the edge of the inspection hatch to 1.5m of any joint and at changes of direction. Bends should be viewable from both directions where the inspection hatch cannot be positioned at the bend.

Where suitable access is not provided the appliance MUST NOT be commissioned and must be disconnected from the gas supply.

Additionally the entire flue and all flue seals must be installed in accordance with the requirements of BS5440:

1. Check condensate trap is filled with water and correctly connected to boiler.
2. All flue joints are correctly made, unstressed and adequately supported.
3. All parts of the flue can be visually inspected -ensure suitable access where flue is positioned within voids-

### 8.5.8 Securing the flue system



#### IMPORTANT

- These regulations are typical for both concentric and Twin flue flue systems.
- The flue system must be secured to a solid structure.
- The flue system should have a continuous fall back to the boiler (1.5° to 3°). N.B. Wall terminals must be installed leveled..
- Only use accompanying brackets.
- Every elbow must be secured by using the bracket.  
Exception at connecting on boiler: If the length of the pipes before and after the first elbow, are no more than 250 mm, the second element after the first elbow has to contain a bracket.  
Note: The bracket must be positioned on the elbow!
- Every extension must be secured per metre with a bracket.  
This bracket must not be clamped around the pipe ensuring free movement of the pipe..
- Make sure bracket is locked into the correct position depending on the position of the bracket on the pipe or elbow:
- Do not mix flue parts or clamps of different suppliers.

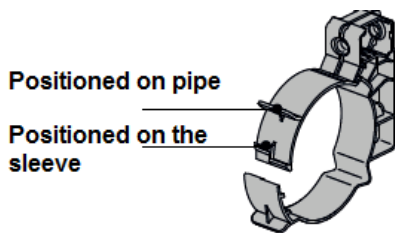

#### Max. distance between clamps

Vertical	Others
2000 mm	1000 mm

- Divide the lengths between the brackets evenly.
- Every system must contain at least 1 bracket.
- Position the first clamp at a maximum of 500 mm from the boiler.

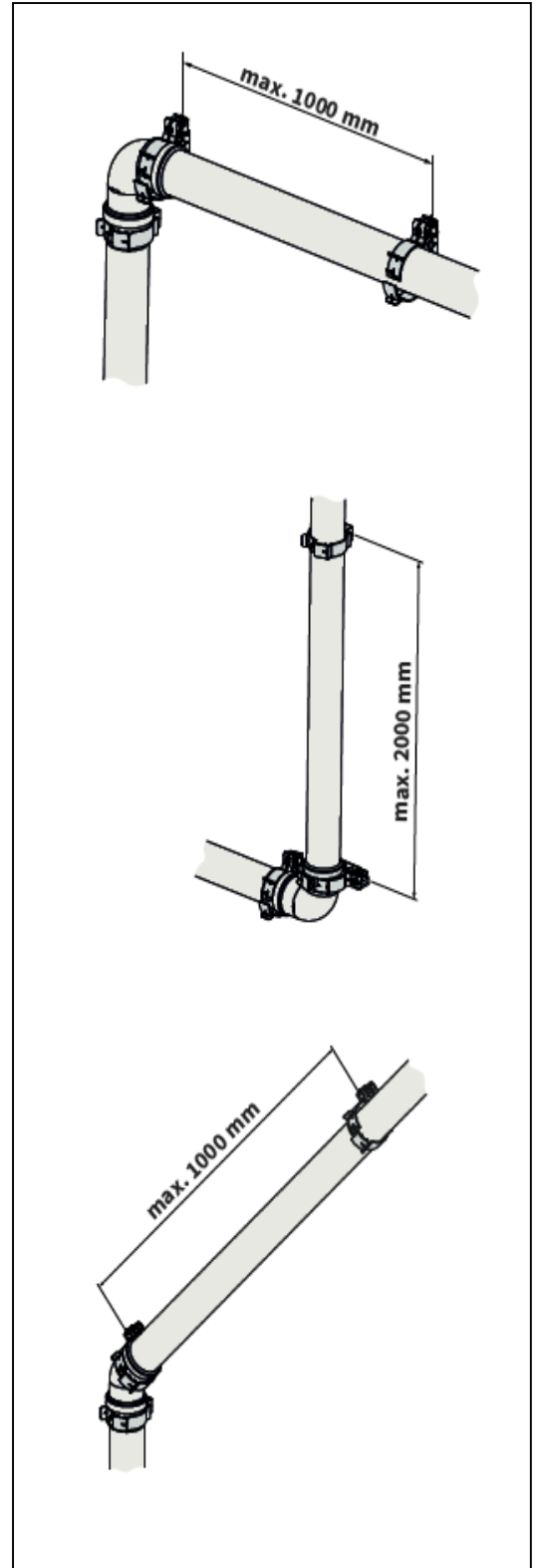

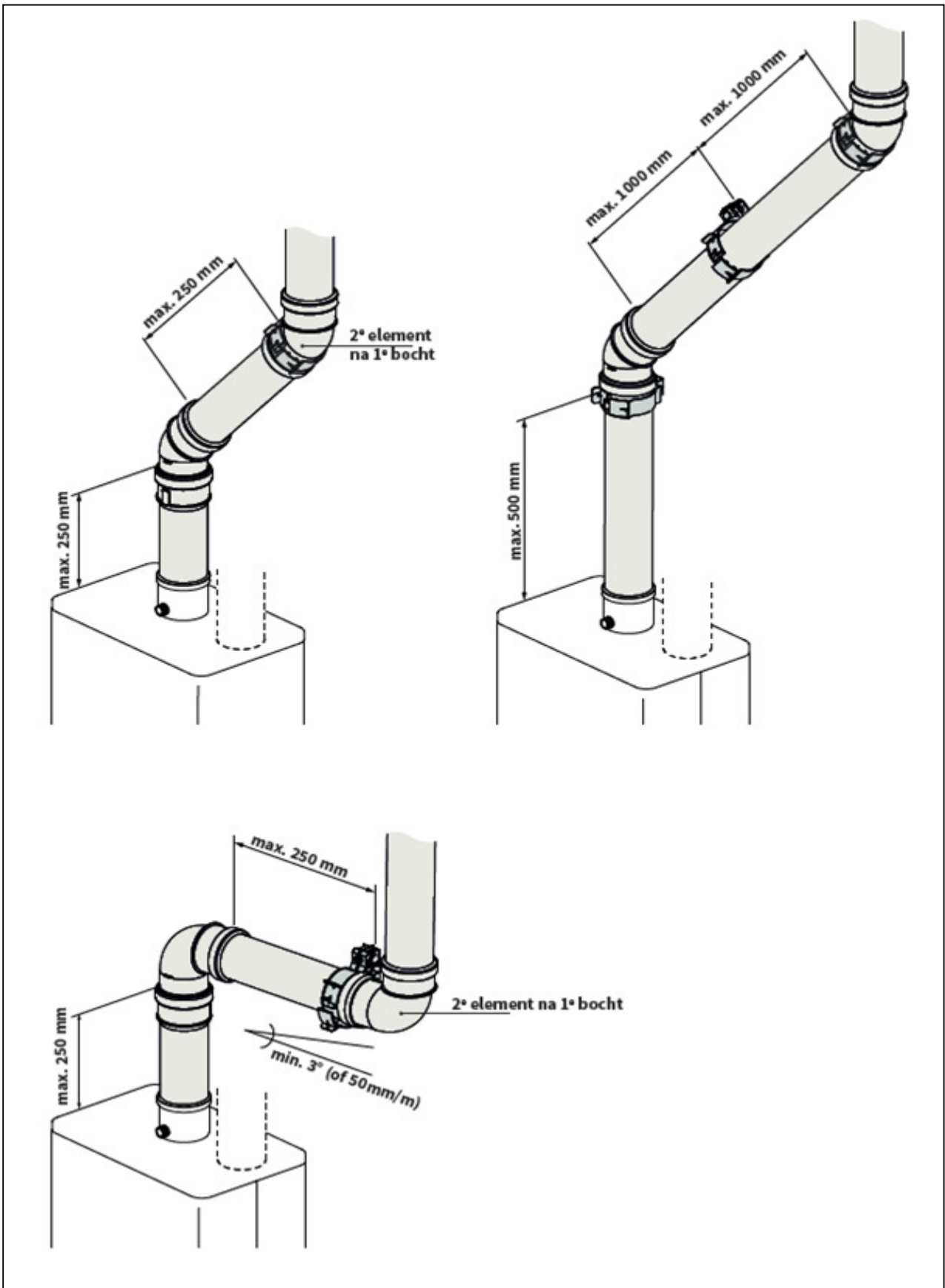

## 9 COMMISSIONING THE APPLIANCE

At the time of commissioning, complete all relevant sections of the Benchmark Checklist located in section 0 of this document.

### 9.1 Filling and venting the appliance and the installation

#### 9.1.1 CH system



#### CAUTION

When an additive is added to the CH water, ensure it is suitable for the materials used in the appliance, such as copper, brass, stainless steel, steel, plastic and rubber.

1. Connect to 3 amp fused spur or an unswitched socket with 3 amp fuse.
2. Fill the heating system feed tank and system.
3. Vent the air in the installation with the manual vent screws on the radiators.
4. Connect the appliance to mains.

The appliance may perform a self test:  (on service display).

The appliance will then go into wait mode:  (on service display).

5. Check all fittings for leaks.
6. Fill the condensate trap with water.

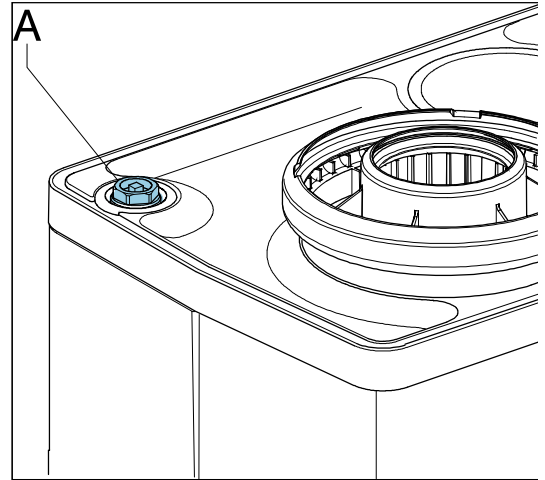

#### 9.1.2 Gas supply

1. Gas supply purged of air via test point D on gas valve (see illustration )
2. Connect a suitable gauge to test point D .  
Static or standing pressure must be 20mb.  
**If 20mb is not obtained DO NOT proceed with commissioning until supply is rectified.**
3. If static pressure is correct fire the boiler and allow to reach working temperature.
4. Test working pressure by selecting test program "H". See § 10.8.1, High Setting.  
Working pressure must be 20 mb.



#### NOTE

The inlet working pressure must be obtained with all other gas appliances at the property working.

5. Please refer to the Benchmark commissioning Checklist on page 58

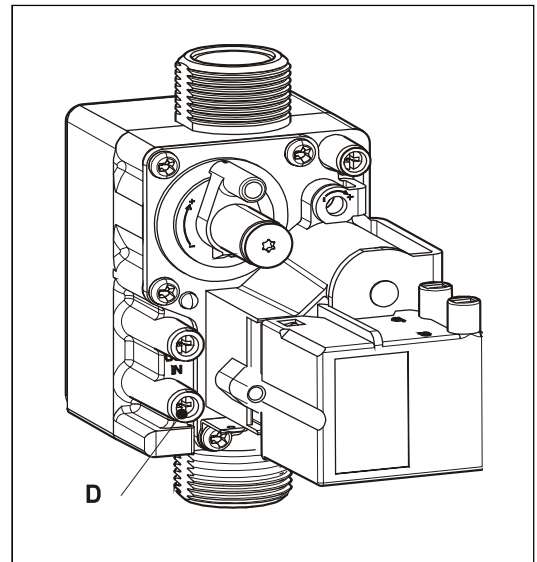

### 9.1.3 Combustion

The combustion for this appliance has been checked, adjusted and preset at the factory for operation on the gas type defined on the appliance data plate. Although the combustion is factory set please check the combustion as required by the Benchmark Guidelines. If adjustment is necessary please refer to page 32. Do not adjust the air/gas ratio valve. Having checked:

- That the boiler has been installed in accordance with these instructions;
  - The integrity of the flue system and the flue seal, as described in § 8.5 and the British Standards codes of practices, specifically BS 5440;
  - The integrity of the boiler combustion circuit and the relevant seals, as described in § 12.3 eg with a flue spillage mirror;
- proceed to put the boiler into operation as follows:
1. Set up the boiler to operate at maximum rate as described in § 10.8.1.  
With the boiler operating in the maximum rate condition check that the CO<sub>2</sub> value measured at sampling point (X) complies with the requirements as described in the table under § 10.8.1  
Ensure that this inlet pressure can be obtained with all other gas appliances in the property working.

### 9.1.4 Flue system

The flue system must be connected correctly to the appliance in accordance with the manufacturer's instructions. The flue termination should also be checked. Where suitable access for a visual inspection of an existing flue system has not been provided the appliance must not be commissioned and it must be disconnected from the gas supply.

Allow 15mm of white tube externally to ensure the black external sealing ring is fitted correctly. No white parts of the flue pipe should be visible externally. Correct fitting of the flue seal as shown in the flue fitting instruction included in the flue package.

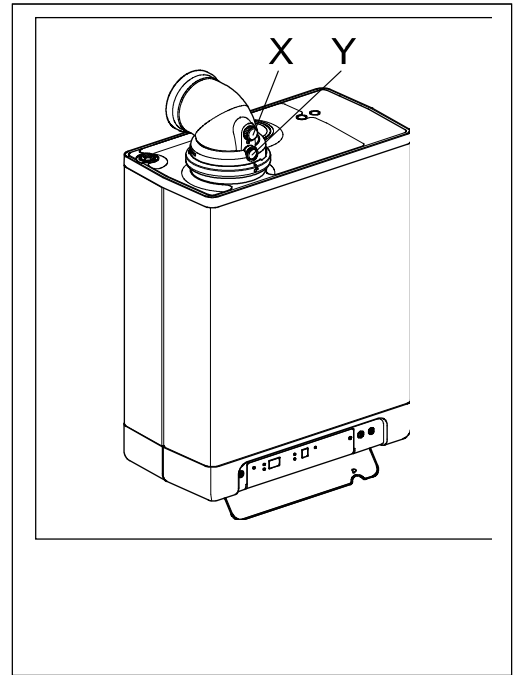



## 9.2 Commissioning the appliance

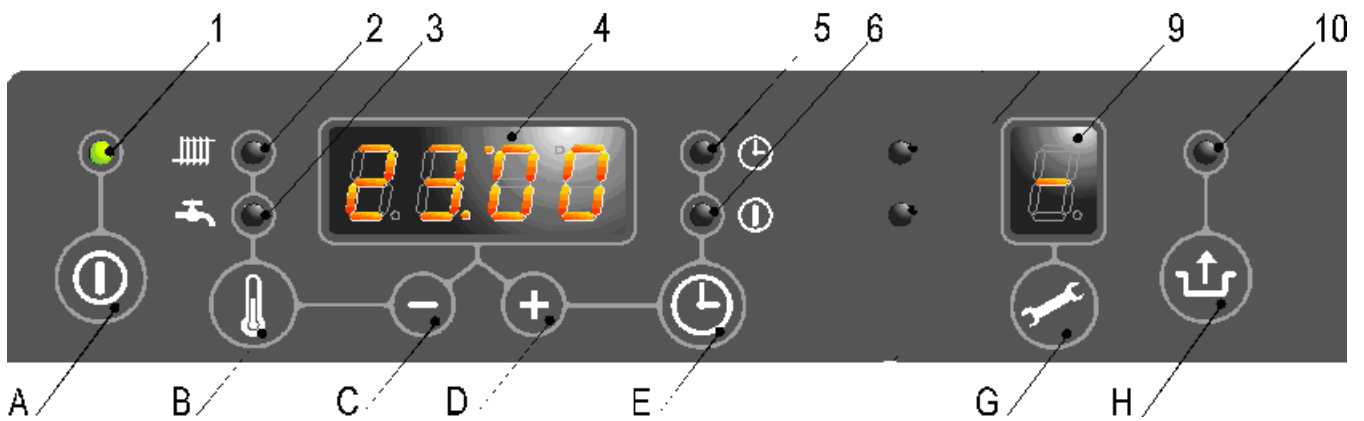

### Read-out

- 1 On / off
- 2 CH operation or setting maximum CH temperature
- 3 DHW operation or setting DHW temperature (**not applicable for Compact HRE OV**)
- 4 Desired temperature of CH or DHW in °C / Fault code/ Time
- 5 Clock "on" CH enabled
- 6 Clock "off" CH disabled
- 7 N/a
- 8 N/a
- 9 Operating code
- 10 Flashes to indicate fault

### Operation

- A On / Off button
- B DHW / CH button, for setting desired temperature
- C - button
- D + button
- E Clock function setting
- F N/a
- G Service button
- H Reset button

Once the preceding actions have been carried out, the appliance may be started up.

1. Press the **A** button, to start the appliance.  
When an indirectly heated DHW storage cylinder is connected the storage cylinder is heated up and the service display will show **3**, **4** and **5** (depending on the status of the DHW disabling switch and/or Open Therm regulation).
2. Adjust the pump setting depending on the maximum power set and the resistance in the CH installation. For the water head of the pump and the pressure loss of the appliance see § 10.5.
3. Set the room thermostat higher than the room temperature. The appliance will now switch to CH operation: **5** will show on the display.
4. Heat the installation and the appliance to approximately 80°C.
5. Check the temperature difference between the supply and return for the appliance and the radiators. This must be approximately 20°C. For this purpose set the maximum power on the service panel. See setting maximum power. If necessary adjust the pump setting and/or the radiator valves. For the minimum flow see § 10.5.
6. Switch the appliance off.
7. Bleed the appliance and the installation after cooling.
8. Check correct operation of the heating and hot water supply.
9. Instruct the user on filling, bleeding and the operation of the clock, heating and hot water supply. For setting the clock see § 9.3.

### Notes







- *The appliance is equipped with an electronic boiler controller, which ignites the burner and continuously monitors the flame during each request for heat from the heating or from the hot water supply.*

## 9.3 Setting and adjusting the clock functions

### 9.3.1 Setting the clock

- Press the  button for less than 1 second and repeat this until "Clock" appears. For adjusting the clock to the correct time press the [+] or [-] button.  
Note: Holding the button for more than 1 second will make the clock run fast.

### 9.3.2 Setting the timer function

- On pressing the  button for more than 2 seconds the clock display will flash.
- The time for each on/off shows in the clock display and the service display shows which on 1 and 3 OR off 2 and 4 time is being set.
- Pressing the  button again will change between the different on/off switching periods.  
The pre-set times are as follows:  
Display :      [06:00] and [1] → Start first period CH on.  
                  [09:00] and [2] → End first period CH off.  
                  [16:00] and [3] → Start second period CH on.  
                  [22:00] and [4] → End second period CH off.
- By pressing the  button the new times will be stored in the boiler controller. In the service display [P] appears.
- When the clock is in period [1] or [3] (CH ON) the clock symbol LED is on.
- When the clock is in period [2] or [4] (CH not active) the  LED is on.
- By pressing the  button over 5 seconds the default setting for the switch moments will be restored.  
In the service display "F-set" appears.
- By pressing the  button the boiler controller will return to the normal situation without storing any changes.

## 9.4 Additional functions

Pressing the  button for less than 1 second the following additional functions can be activated:

1. t-on (temporary on).  
The boiler will respond on every CH demand from the room thermostat or external controls until the next switch moment
2. c-on (continuous on).  
The boiler will respond on every CH demand from the room thermostat or external controls without any time limit.
3. OFF  
The boiler will not respond on any CH demand from the room thermostat or external controls..

## 9.5 Shutting down



### CAUTION



Drain the appliance and the installation if mains power has been interrupted and there is a possibility of freezing.

1. Drain the appliance at the drain tap.
2. Drain the installation at the lowest point.

#### 9.5.1 Frost protection

- To avoid freezing of the condensate drain pipe the appliance must be installed in a frost-free area.
- To avoid freezing of the appliance it is equipped with frost protection. If the temperature of the heat exchanger becomes too low, the burner switches on until the temperature of the heat exchanger is sufficient. If there is a possibility of the installation (or part of it) freezing, an (external) frost thermostat must be installed at the coldest point of the return pipe. This must be connected in accordance with the wiring diagram (See chapter 13).

#### Note

*If an (external) frost thermostat has been fitted to the installation and connected to the appliance, this will not be active when the appliance is switched off at the operating panel (  on service  display).*

## 10 SETTING AND ADJUSTMENT



The functioning of the appliance is determined primarily by the (parameter) settings in the boiler controller. Part of this can be set directly via the operating panel; another part can only be adjusted using the installer code.

### 10.1 Directly via the operating panel



The following functions can be operated directly:

#### 10.1.1 Appliance on/off







The appliance is started using the  key.

When the appliance is in operation the green LED above the  key will light up. When the appliance is off a single dash lights up on the service display () to indicate that supply voltage is present. In this mode the pressure in the CH installation (in bar) can also be read on the temperature display.

#### 10.1.2 Resetting

When a lock-out is indicated by means of a flashing LED above the  key and a code on the temperature display, the appliance can be restarted by pressing the  key. Check the nature of the fault on the basis of the fault codes in § 11.1 and resolve the cause of the fault if possible before resetting the appliance.

#### 10.1.3 Changing the settings of the various functions:



Holding the  key pressed in for 2 seconds takes you to the user settings menu (LED at  and the figure display start to flash). Pressing the  key repeatedly results in a different function LED flashing each time. When the LED is flashing the indicated function can be set with the  and  key. The value set is shown on the  display.



The  on/off key closes the settings menu without storing the changes.

The reset  key closes the settings menu and the changes are stored.

If no key is pressed during a period of 30 seconds, the settings menu is closed automatically and the changes are stored.

#### 10.1.4 Maximum CH supply temperature











Press the  key until the LED at  starts to flash.

With the  and  keys set the temperature between 30°C and 90°C (default value 80°C).

### 10.2 Setting via the service code

The boiler controller in the appliance is factory set in accordance with the parameters.

These parameters can only be changed using the service code. Proceed as follows to activate the program memory:

1. Press the  and  keys simultaneously until a  appears on the service- and temperature display.
2. Using the  and  keys set  (service code) on the temperature display.
3. Using the  key set the parameter to be set on the service display.
4. Using the  and  keys set the parameter to the desired value (visible) on the temperature display.
5. Once all desired changes have been entered, press the  key until a  appears on the service display.

The boiler controller has now been reprogrammed.

- Pressing the  key in takes you out of the menu without storing the parameter changes.

### 10.3 Parameters

Setting	Compact HRE OV Factory settings			Description	Parameter
	18	24	30		
Service code [15]	-	-	-	Access to installer settings The service code must be entered (= 15)	0
Installation type	3	3	3	0= Combi 1= Heating only + external DHW tank 2= DHW only (no heating system required) 3= Heating only	1
CH pump continuous	0	0	0	0= post purge period only 1= pump continuously active 2= pump continuously active with MIT switch 3= pump on with external switch	2
Maximum CH power set	85	85	85	Adjustment range of set value parameter c up to 85% or up to 99 (HRE 36/40 only)	3
Max. power modulating pump	80	80	80	Not applicable	3.
Maximum DHW power set	85	85	85	Adjustment range of set value parameter d up to 99% or 75 % (HRE 36/40 only)	4
Min. supply temperature of the heat curve	25	25	25	Adjustment range 10°C to 25°C	5
Max. value flow temperature in display (end user setting)	80	80	80	Adjustment range 30°C to 90°C	5.
Min. outside temperature of the heat curve	-7	-7	-7	Adjustment range -9°C to 10°C	6
Max. outside temperature of the heat curve	25	25	25	Adjustment range 15°C to 30°C	7
CH pump post purge period	1	1	1	Adjustment range 0 to 15 minutes	8
CH pump post purge period after DHW operation	1	1	1	Adjustment range 0 to 15 minutes (N.a. for Combi Compact appliance)	9
Booster	0	0	0	N.a.	b
Step modulation	1	1	1	0= step modulation off during CH operation 1= step modulation on during CH operation	C
Minimal CH rpm	30	30	30	Adjustment range 25 to 50 %	C
External switch keep hot facility	40	40	40	Not applicable	c.
Minimal DHW rpm	25	25	25	Adjustment range 25 to 50%	D
Min. Supply temperature during OT demand (OT= OpenTherm thermostat)	40	40	40	Adjustment range 10°C to 60°C	E
OT response	1	1	1	0= ignore OT if < E 1= limit OT if < E 2= OT on-off	E.
Start rpm CH	70	70	70	Adjustment range 50 to 99% of the set maximum rpm	F
Start rpm DHW	70	70	70	Adjustment range 50 to 99% of the set maximum rpm	F.
Max. fan rpm (factory setting)	45	44	84	Adjustment range: nominal value ± 200 rpm. With this parameter the maximum rpm can be set	H
Legionella prevention (only applicable when using external tank and W-plan)	0	0	0	0 = Legionella prevention disabled 1 = Legionella prevention weekly 2 = Legionella prevention daily	L
Set point CH (flow temperature) during heating external DHW tank	85	85	85	Adjustment range 60°C to 90°C	n
Keep hot temperature Eco/Comfort mode	0	0	0	Not applicable	n.
Delay time for responding on CH demand	0	0	0	Not applicable	O.
Waiting time after a DHW demand before a CH demand is answered	0	0	0	Adjustment range 0 to 15 minutes	O
Eco days	3	3	3	Not applicable	o.
Anti cycle time (Delay time reacting on CH demand after exceeding maximum setting CH temp.)	5	5	5	Adjustment range 0 to 15 minutes	P
Ref.value DHW	0	0	0	Not applicable	P.
Summer mode	0	0	0	Not applicable	q
Heating curve coefficient	0	0	0	Not applicable	r

### 10.4 Setting maximum CH power

The maximum CH power is set at 70% in the factory. If more or less power is necessary for the CH installation, the maximum CH power can be changed by changing the fan rpm. See table Setting CH power.

This table shows the relationship between the fan rpm and the appliance power.

#### Setting CH power

Desired CH power (in kW approx.)			Setting on service display (in % of max. rpm)
18 OV	24 OV	30 OV	
17,8	22,8	26,3	± 83
14,8	19,1	22,6	70
12,7	16,4	19,0	60
10,6	13,7	15,8	50
8,3	11,0	12,7	40
6,4	8,3	8,5	30
5,4	6,9	7,1	25

#### Note

The power during burning is increased slowly and is reduced as soon as the set supply temperature is reached (modulate on T flow).

### 10.5 Adjusting pump setting

If an external pump is used, depend on the type used the pump setting can be adjusted. Consult the manual of the external pump for advice.

Check the temperature difference between the appliance supply and return: this must be approximately 20°C.

The minimum flow quantity	Power setting
155 l/h	5,4 kW
510 l/h	17,8 kW
650 l/h	22,8 kW
750 l/h	26,3 kW

#### Appliance pressure loss graph, CH side

- A. Compact HRE 18 OV
- B. Compact HRE 24 OV
- C. Compact HRE 30 OV
- X Flow in l/h
- Y Pressure loss / water head in mH<sub>2</sub>O

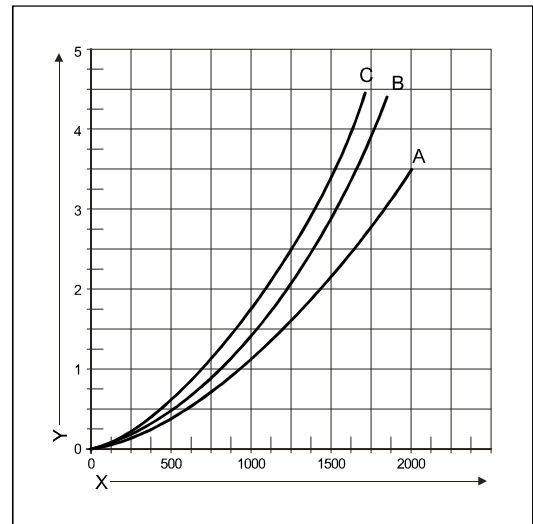

### 10.6 Weather-compensation adjustment

When an external sensor is connected the supply temperature is adjusted automatically depending on the outside temperature, in accordance with the heating line set.

The maximum supply temperature (Tmax) is set via the temperature display. If desired, the heating line can be changed in the parameter list. See § 10.3.

#### Heating line graph

- X. Outside T in °C
- Y. Supply T in °C
- A. Factory setting  
(Tmax CH = 80°C, Tmin CH = 25°C, Tmin out = -7°C, Tmax out = 25°C)
- B. Example  
(Tmax CH = 60°C, Tmin CH = 25°C, Tmin out = -7°C, Tmax out = 25°C)

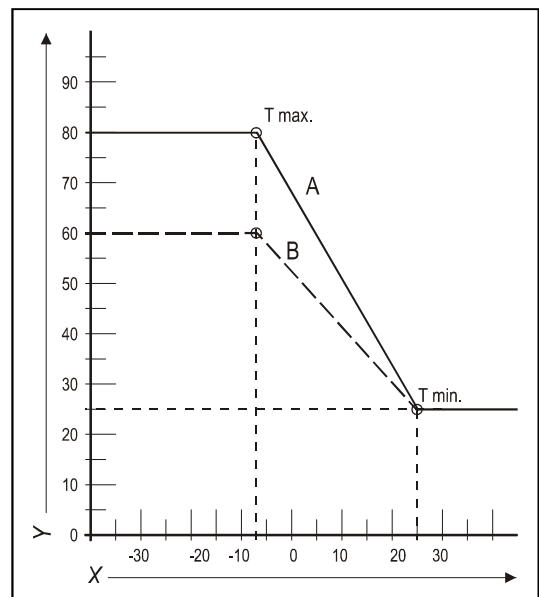

## 10.7 Gas-Air ratio control

The gas air ration control of the boiler is set to the correct value in the factory and does not need to be adjusted. The gas type of the boiler on which the boiler has been set is noted on the data plate.

The boiler is only to be used in combination with this gas type.

When necessary the boiler can be converted to another gas type using the appropriate conversion set. See the table below for the correct gas ring.

**Table 1, inserts and associated gas rings per boiler type.**

Model	Insert number	Gas category	
		Natural gas G20 20 mBar	LPG G31 37 mBar
		Gas ring	
18 OV	471	505	410
24 OV	406	600	480
30 OV	362	655	525

The correct setting of the Gas-Air ratio can be checked by measuring the flue gases using a calibrated O<sub>2</sub> measuring device. The measurement must be performed first at maximum power and thereafter on the minimum power. (see § 10.8.1 and § 10.8.2). For reference reasons the tables below contain O<sub>2</sub> and CO<sub>2</sub> values.

When the CO<sub>2</sub> or O<sub>2</sub> value is incorrect only the setting on minimum power can be adjusted (see § 10.8.3 ) by changing the setting of the gas valve.

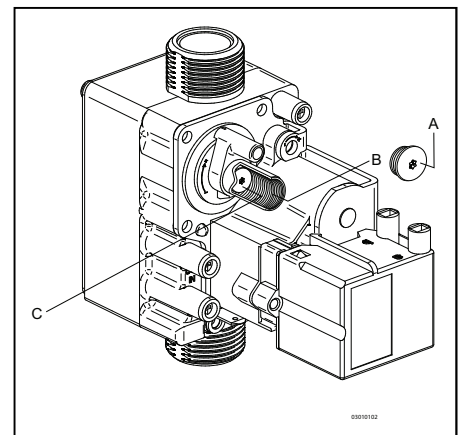
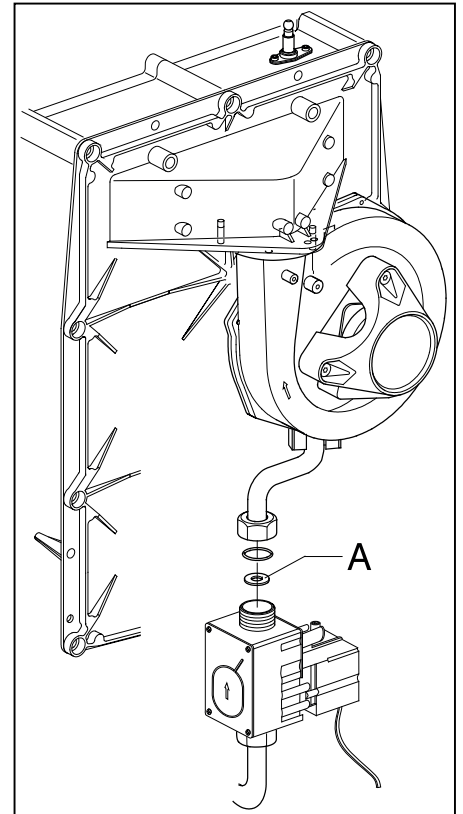

### Important



- During the CO<sub>2</sub> or O<sub>2</sub> check the front casing of the boiler needs to be removed.
- The deviation of the O<sub>2</sub> analyser must be restricted to +/- 0.3%
- A reliable measurement is only guaranteed when no extreme vacuum in the flue pipe is present (i.e. draft due to hard wind).
- A deviation at maximum power can not be adjusted with the gas valve setting. When the value measured at maximum power is without the prescribed range the boiler has to be checked on gas tightness and usage of the correct components, in particular the gas ring and the fan.
- When replacing parts or converting the boiler to another gas type the correct functioning of the gas air ration always has to be checked.

## 10.8 Checking the gas air ratio control

### 10.8.1 Checking flue gas at maximum power.

1. Switch the appliance off with the **⏻** button .  
[-] will appear in service display.
2. Remove the front panel by untightening the 2 screws.
3. Remove the cap X of the flue gas sampling point on the adapter.
4. Position the measuring probe or the flue gas analyser into the sampling point.

#### Important



- Ensure yourself that the analyser start up procedure has been finalised before placing the probe.
- The probe needs to close the sampling point fully to ensure an accurate measurement
- The end (tip) of the probe must be completely in the flue gasses (in the middle of the flue pipe)

5. Switch the appliance on with the **⏻** button .
6. Activate the test program for maximum output by simultaneously pressing the buttons **↶** and **+** twice. A capital **H** appears in service display.

#### Important



- Make sure a capital **H** is shown in the display to ensure the appliance to run at maximum power.

7. Wait until the reading of the flue gas analyser is stable (minimal 3 minutes)
8. Note the measured value  $O_2(H)$  or  $CO_2(H)$   
 $O_2(H)$  = measured  $O_2$  value at maximum power  
 $CO_2(H)$  = Measured  $CO_2$  value at maximum power
9. Check if the measured value is in accordance with the data noted in table 2a or 2b .

**Table 2a: Limits  $O_2(H)$  at maximum power (open casing)**

Limits	Gas category	
	Natural gas G 20	LPG G31
	$O_2$ [%]	$O_2$ [%]
Maximum value	5.60	6.05
Minimum value	3.85	4.50

**Table 2b: Limits  $CO_2(H)$  at maximum power (open casing)**

Limits	Gas category	
	Natural gas G 20	LPG G31
	$CO_2$ [%]	$CO_2$ [%]
Maximum value	9.6	10.8
Minimum value	8.6	9.8



#### Important

- A deviation at maximum power can not be adjusted with the gas valve setting. When the value measured at maximum power is without the prescribed range the boiler has to be checked on gas tightness and usage of the correct components, in particular the gas ring, the insert and the fan.

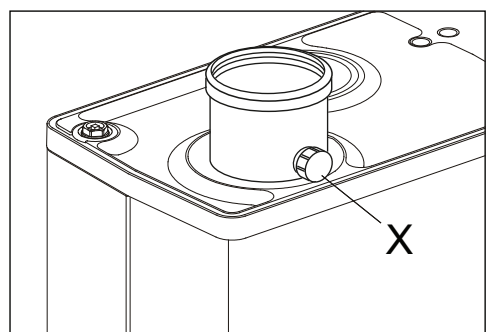
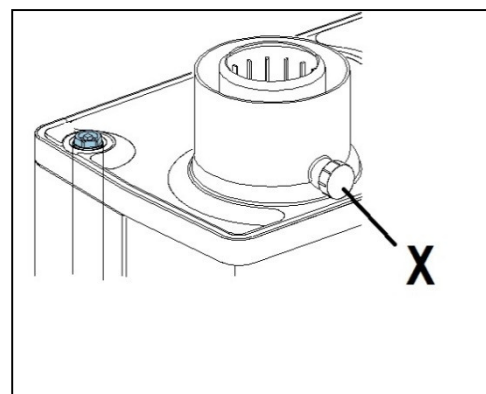
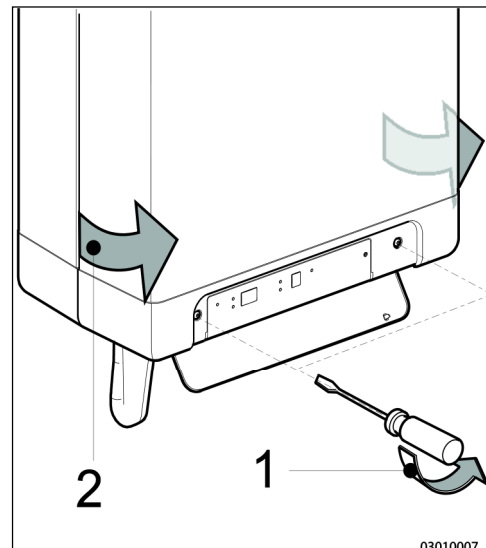

10. Proceed performing the measurement on minimum output (see § 10.8.2).





## 10.8.2 Checking flue gas at minimum output

Before measuring the flue gasses at minimum output the measurement of the maximum output must be completed. The measured O<sub>2</sub> or CO<sub>2</sub> value at maximum output is important for determining the correct value for the measurement at minimum output. See § 6.8.1 for measuring at maximum output

1. Activate the test program for maximum output by simultaneously pressing the buttons  and . A capital L appears in service display.
2. Wait until the reading of the analyser is stable (min. 3 minutes)
3. Note the measured value O<sub>2</sub>(L) orf CO<sub>2</sub>(L).  
O<sub>2</sub>(L) = is the measured value of O<sub>2</sub> at minimum power  
CO<sub>2</sub>(L) = is the measured value of CO<sub>2</sub> at minimum power
4. Check if the measured value is in accordance to the data in table 3a or 3b



The O<sub>2</sub> lower limit is the value of O<sub>2</sub>(H) noted during the measurement at maximum output .  
The CO<sub>2</sub> upper limit is the value of CO<sub>2</sub>(H) noted during the measurement at maximum output.  
(See § 10.8.1 )

**Table 3a: limits O<sub>2</sub>(L) at minimum output (open casing)**

Limits	Gas category	
	Natural gas G20	LPG G31
	O <sub>2</sub> [%]	O <sub>2</sub> [%]
Maximum value	6.00	6.65
Minimum value	O <sub>2</sub> (H)	O <sub>2</sub> (H) + 0.5

**Table 3b: limits CO<sub>2</sub>(L) at minimum output (open casing)**

Limits	Gas category	
	Natural gas G20	LPG G31
	CO <sub>2</sub> [%]	CO <sub>2</sub> [%]
Maximum value	CO <sub>2</sub> (H)	CO <sub>2</sub> (H) – 0.3
Minimum value	8.4	9.4







### Important

- The gas-air ratio is set correctly when the measured value at minimum output is within the upper and lower limit. Adjusting the gas-air ratio is not advised.
- The gas-air ratio needs to be adjusted in accordance to § 10.8.3 when the measured value at minimum output is not within the upper and lower limit.





### For example (Natural gas G20)

During maximum output a O<sub>2</sub>(H) value of 4.0 % has been measured. In that case the O<sub>2</sub>(L) value at minimum output must be in-between 4 % (= value O<sub>2</sub>(H)) and 6.05% as stated in the table. When during minimum output a value out of this range is measured the gas-air ratio must be adjusted..

5. Proceed, in case of a deviating value by adjusting the gas valve in accordance to § 10.8.3.  
In case of a correct setting continue with point 6.
6. Fit the front panel to the appliance and tighten the 2 screws.  
Check the values for CO at minimum output (= max. 160 ppm)
7. Activate the test program for maximum output by simultaneously pressing the button  and  twice.  
A capital H appears in service display.  
Check the values for CO at maximum output (= max. 160 ppm)
8. Switch the appliance off with the  button .
9. Remove the measuring probe of the flue gas analyser and replace the cap on the sampling point.
10. Check the tightness of the sampling point
11. Switch the appliance off with the  button and check that the appliance is functioning well.

### 10.8.3 Correction gas air ratio on minimum power

Before the correction of the gas air ratio on minimum output the measurement of the maximum output must be completed. The measured O<sub>2</sub> or CO<sub>2</sub> value at maximum output is important for determining the correct value for the measurement at minimum output. See § 10.8.1 and § 10.8.2 for measuring at maximum output.

1. Remove the cover cap (A) on the gas valve so setting screw B will become attainable.
2. Activate the test program for minimum output by simultaneously pressing the buttons  and . A capital L appears in service display.
3. Wait until the reading of the analyser is stable (min. 3 minutes).
4. Measure the O<sub>2</sub>(L) or CO<sub>2</sub>(L) value
5. Set, using adjustment screw B de correct value for O<sub>2</sub>(L) or CO<sub>2</sub>(L).  
See table 5a or 5b for the correct value



- Choose the correct table (4a and 5a is for natural gas, 4b and 5b is for Propane).
- The value measured at maximum output as noted during the measurement on maximum output (CO<sub>2</sub>(H) or O<sub>2</sub>(H) )  
Turning clockwise of the adjustment screw will raise the CO<sub>2</sub> value and lower the O<sub>2</sub> value. Turing anti clockwise will raise the O<sub>2</sub> value and lower the CO<sub>2</sub> value.
- Change the setting in small steps and wait until the reading is stable before continue.

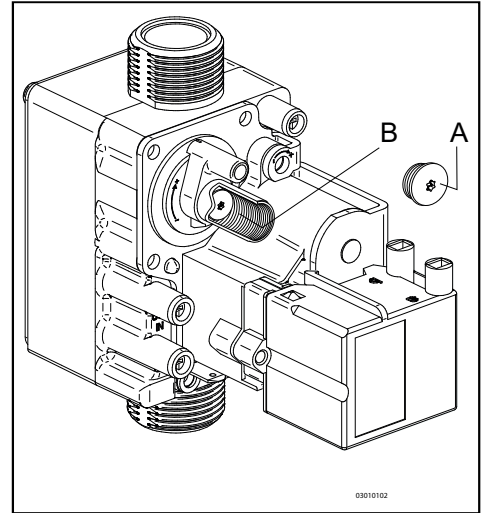

**Table 4a: Determining the correct setting of O<sub>2</sub> at minimum output for natural gas G20 (open casing)**

Natural gas G20 (20 mBar)	
Measured value am maximim power (See § 10.8.1)	Prescribed value at minimum power (= 0.5 x O <sub>2</sub> (H) + 3.0)
O <sub>2</sub> (H) [%]	O <sub>2</sub> (L) [%]
5.60	5.80 ±0.2
5.30	5.65 ±0.2
5.00	5.50 ±0.2
4.70	5.35 ±0.2
4.40	5.20 ±0.2
4.10	5.05 ±0.2
3.85	4.90 ±0.2

**Table 4b: Determining the correct setting of O<sub>2</sub> at minimum output for LPG G31 (open casing)**

LPG G31 (37 mBar)	
Measured value am maximim power (See § 10.8.1)	Prescribed value at minimum power (= O <sub>2</sub> (H) + 0.5)
O <sub>2</sub> (H) [%]	O <sub>2</sub> (L) [%]
6.05	6.55 ±0.2
5.70	6.20 ±0.2
5.40	5.90 ±0.2
5.10	5.60 ±0.2
4.80	5.30 ±0.2
4.50	5.00 ±0.2

**Table 5a: Determining the correct setting of CO<sub>2</sub> at minimum output for natural gas G20 (open casing)**

Natural gas G20 (20 mBar)	
Measured value at maximum power (See § 10.8.1)	Prescribed value at minimum power (= 0.5 x CO <sub>2</sub> (H) + 4.2)
CO <sub>2</sub> (H) [%]	CO <sub>2</sub> (L) [%]
9.6	9.0 ±0.1
9.4	8.9 ±0.1
9.2	8.8 ±0.1
9.0	8.7 ±0.1
8.8	8.6 ±0.1
8.6	8.5 ±0.1

**Table 5b: Determining the correct setting of CO<sub>2</sub> at minimum output for G31 (open casing)**

LPG G31 (37 mBar)	
Measured value at maximum power (See § 10.8.1)	Prescribed value at minimum power (= CO <sub>2</sub> (H) - 0.3)
CO <sub>2</sub> (H) [%]	CO <sub>2</sub> (L) [%]
10.8	10.5 ±0.1
10.6	10.3 ±0.1
10.4	10.1 ±0.1
10.2	9.9 ±0.1
10.0	9.7 ±0.1
9.8	9.5 ±0.1

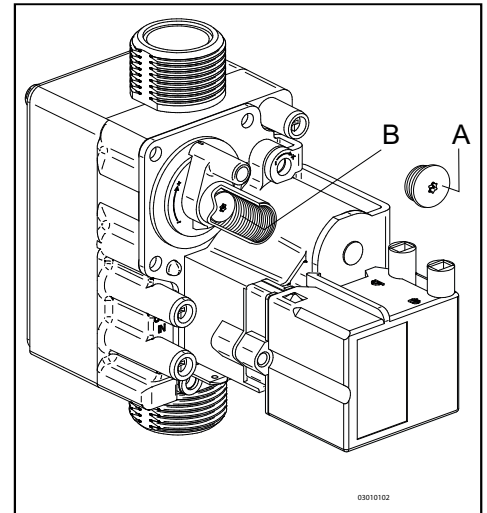

03010102



**Example (when using natural gas G20)**

During the measurement at maximum output the value of O<sub>2</sub>(H) was 4.1 %.  
The setting for O<sub>2</sub>(L) at minimum output will then be 5.05 ± 0,2 %

1. Replace the cap A of the adjustment screw B for protection
2. Repeat the measurement at maximum and minimum output (§ 10.8.1 and § 10.8.2) to ensure the correct operation of the boiler.



**Important**

Work on gas carrying parts may only be carried out by a qualified competent person.

## 10.9 Conversion to different gas type



### CAUTION

Work on gas carrying parts may only be carried out by a qualified competent person.

If a different type of gas is connected to the appliance than that for which the appliance has been set by the manufacturer, the gas metering ring should be replaced. Conversion sets for other types of gas are available to order.

#### 10.9.1 Converting the gas restriction.

1. Switch the boiler off and isolate the boiler from the mains power.
2. Close the gas isolation valve.
3. Remove the front panel from the appliance.
4. Unscrew the coupling (A) above the gas valve and twist the gas mixing tube towards the rear (B).
5. Replace the O-ring (C) and the gas restriction (D) with the rings from the conversion set.
6. Re-assemble in reverse sequence.
7. Open the gas isolation valve.
8. Check the gas connections before the gas valve for gas-tightness.
9. Switch on the mains power.
10. Check the gas connections after the gas valve for gas-tightness (during operation).
11. Now check the setting of the CO<sub>2</sub> percentage at high setting (H in display) and low setting (L in display).



### CAUTION

It is not possible to adjust the CO<sub>2</sub> level at high setting. When the CO<sub>2</sub> percentage at high setting is not within the prescribed tolerance band please contact Intergas Heating.

For adjusting CO<sub>2</sub> level at low setting see § 10.8.

12. Place a sticker for the gas type set over the existing sticker next to the gas valve.
13. Place a sticker for the gas type set next to the identification plate.

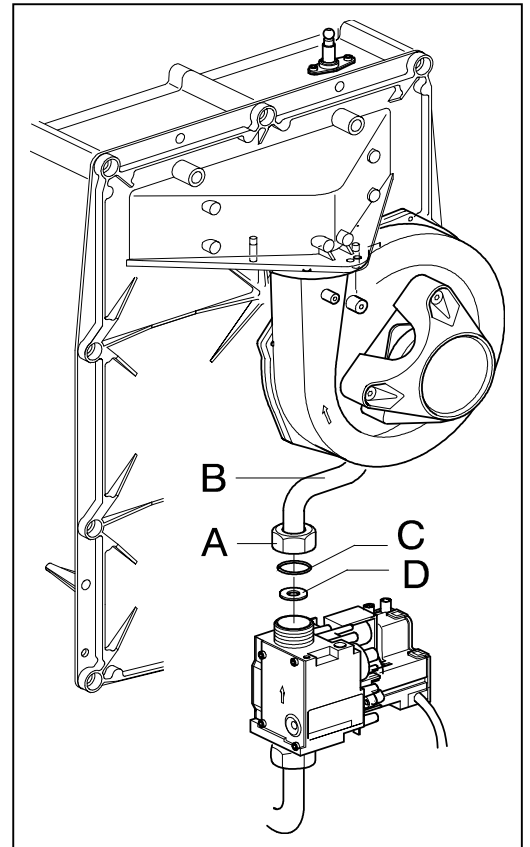

# 11 FAULTS

## 11.1 Fault codes

If the fault LED is flashing, the boiler controller has detected a fault. A fault code will be indicated on the temperature display.

Once the fault has been rectified the boiler controller can be restarted.

Press the reset  key on the operating panel.

The following faults are distinguished

Temperature display	Display Fault	Possible Solution
10, 11, 12, 13, 14	Sensor fault S1	<ul style="list-style-type: none"> <li>Boiler needs venting (manual air vent top left of boiler)</li> <li>Check wiring for break, check for break or trapped wires</li> <li>Replace S1</li> <li>DHW flowswitch or flowsensor</li> </ul>
20, 21, 22, 23, 24	Sensor fault S2	<ul style="list-style-type: none"> <li>Check wiring for break</li> <li>Replace S2</li> </ul>
0	Sensor fault after self check	<ul style="list-style-type: none"> <li>Replace S1 and/or S2</li> </ul>
1	Temperature too high	<ul style="list-style-type: none"> <li>Air in installation</li> <li>Pump not running</li> <li>Unsuufficient flow in installation, radiators closed, pump setting too low</li> <li>Flow switch sticking</li> </ul>
2	S1 and S2 interchanged	<ul style="list-style-type: none"> <li>Check cable loom</li> <li>Replace S1 or S2</li> </ul>
4	No flame signal	<ul style="list-style-type: none"> <li>Gas isolation valve closed, No gas at meter</li> <li>No or incorrect ignition gap, replace ignition pin</li> <li>Faulty burner</li> <li>Check for earth fault</li> <li>Gas supply pressure too low, faulty governor at gas meter</li> <li>Gas valve or ignition module not powered</li> <li>Boiler controller (PCB)</li> </ul>
6	Flame detection fault	<ul style="list-style-type: none"> <li>Replace ignition cable + spark plug cap</li> <li>Replace ignition unit</li> <li>Replace boiler controller (PCB)</li> </ul>
8	Incorrect fan speed	<ul style="list-style-type: none"> <li>Fan catching on casing</li> <li>Wiring between fan and casing</li> <li>Check wiring for poor wire contact</li> <li>Replace fan*</li> </ul>
27	Shortcut outside sensor	<ul style="list-style-type: none"> <li>Replace the outside sensor</li> </ul>
29,30	Gas valve relay faulty	<ul style="list-style-type: none"> <li>Replace boiler controller</li> <li>Replace ignition module</li> </ul>



### CAUTION

Always use original Intergas spare parts when replacing components.

Failure to fit the sensors S1 and/or S2, or to fit them correctly can result in serious damage.



### CAUTION

\* The boiler is equipped with a non-return valve (A), positioned above the fan. Check that the valve is still in good condition and ensure the non-return valve is repositioned correctly when replacing the fan.

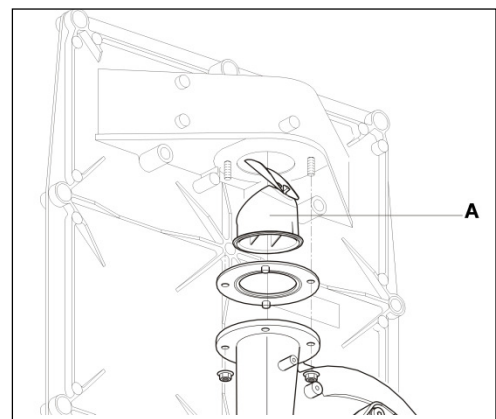

## 11.2 Other faults

### 11.2.1 Burner does not ignite

Possible causes:

Gas tap is closed.

No ↓

Air in the gas pipe.

No ↓

Gas supply pressure too low.

No ↓

No ignition.

No ↓

No spark. Ignition unit on gas valve faulty.

No ↓

Gas/air adjustment not correctly set.

No ↓

Fan faulty.

No ↓

Fan dirty.

No ↓

Gas valve faulty.

Solution:

Open gas tap.

Remove air from gas pipe.

Contact the gas supply company.

Replace ignition electrode.

Check the cabling. Check the spark plug cap. Replace the ignition unit.

Check adjustment. See gas/air adjustment.

Check the wiring. Check the fuse, if necessary, replace the fan.

Clean the fan.

Replace the gas valve. Re-adjust the gas valve, see gas/air adjustment.

### 11.2.2 Burner ignites noisily

Possible causes:

Gas supply pressure too high.

No ↓

Incorrect ignition gap.

No ↓

Gas/air adjustment not correctly set.

No ↓

Weak spark.

Solution:

The house pressure switch may be faulty. Contact the gas company.

Replace the ignition pin.  
Check the ignition electrode gap.

Check the setting. See gas/air adjustment.

Check the ignition gap.  
Replace the ignition electrode.  
Replace the ignition unit on the gas valve.

Checking ignition pin position using test tool

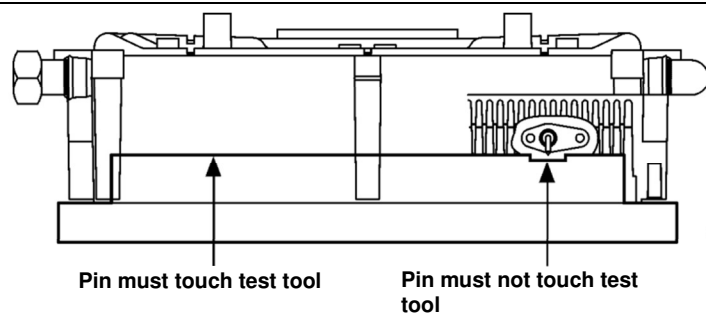

### 11.2.3 Burner resonating

Possible causes:

Gas supply pressure too low.

No ↓

Recirculation of combustion gasses.

No ↓

Gas/air adjustment not correctly set.

Solution:

The house pressure switch may be faulty. Contact the gas company.

Check the gas flue and the air supply.

Check the setting, see gas/air adjustment.

### 11.2.4 No heating (CH)

Possible causes:

Room thermostat / weather-dependent adjustment not closed or faulty.

No ↓

No current (24 V).

No ↓

Pump not running.

No ↓

Burner not firing on CH: sensor S1 or S2 faulty.

No ↓

Burner does not ignite.

Solution:

Check the wiring.  
Replace the thermostat.  
Replace the weather-dependant adjustment.

Check the wiring against the diagram.  
Check the connector X4.  
Replace the faulty manager.

Check the power supply.  
Check connector X2.  
Replace faulty pump.

Replace sensor S1 or S2. See fault code.

See burner does not ignite.

### 11.2.5 The power is reduced

Possible causes:

At high rpm the power has fallen by more than 5%.

Solution:

Check appliance and flue system for fouling.  
Clean the appliance and flue system.

### 11.2.6 CH does not reach temperature

Possible causes:

Room thermostat setting incorrect.

No ↓

Temperature is too low.

No ↓

Pump not running correctly. Pump setting is too low.

No ↓

No circulation in the installation.

No ↓

The boiler power has not been correctly set for the installation.

No ↓

No heat transfer as a result of lime scale or fouling in the heat exchanger.

Solution:

Check the setting and if necessary adjust: Set to 0.1A.

Increase the CH temperature. See Operating CH . Check outside sensor for short-circuiting. Rectify.

Increase pump setting, or replace the pump.

Check whether there is circulation: at least 2 or 3 radiators must be open.

Adjust the power. See setting maximum CH power.

De-scale or flush the heat exchanger on the CH side.

### 11.2.7 No hot water (only when an indirectly heated DHW storage cylinder is applied)

Possible causes:

No current at the diverter valve.

No ↓

Diverter valve does not switch.

No ↓

No current at the DHW storage cylinder sensor/thermostat.

No ↓

Burner does not ignite on DHW: DHW storage cylinder sensor/thermostat defect.

No ↓

Burner does not ignite.

Solution:

Check the wiring according to the diagram.

Replace diverter valve.

Check the wiring according to the diagram.

Replace DHW storage cylinder sensor/thermostat.

See burner does not ignite.

**11.2.8 Hot water does not reach temperature (only when an indirectly heated DHW storage cylinder is applied)**

Possible causes:

No ↓

Temperature setting for DHW storage cylinder too low.



Solution:

Set the DHW storage cylinder temperature. See 10 Setting and adjustment.



## 12 MAINTENANCE

The appliance and the installation should be checked and if necessary cleaned every year by a registered expert.

For assembly and disassembly the following tools can be used:

1. Cross head screwdriver
2. Allen key 6 mm
3. Adjustable spanner

After servicing, complete the relevant Benchmark Service Record section located on page 57 of this document.



### CAUTION

Work on gas carrying parts may only be carried out by an authorised installer.

When the appliance has just been operating parts may be hot. Domestic use only. Service intervals may need to be increased depending on commercial usage. This includes seals being replaced more frequently. For additional information please contact Intergas Heating Ltd.



### CAUTION

The integrated insulation and burner seal contain ceramic fibres.

### 12.1 Disassembly

1. Switch the boiler off and isolate the boiler from the mains power.
2. Close the gas isolation valve.
3. Open the display cover and turn the two screws on the left- and right-hand side of the display and remove the front panel.
4. Wait until the appliance has cooled down.
5. Unscrew the coupling nut at the base of the flue pipe anti-clockwise.
6. Slide the flue pipe upwards (1) turning it anti-clockwise until the bottom of the pipe is above the condensate drain pan connection. Pull the bottom of the pipe forwards (2) and remove the pipe downwards (3) turning it anti-clockwise.
7. Lift the condensate drain pan on the left-hand side from the connection to the condensate trap (4) and turn it to the right with the condensate trap connection over the edge of the base tray (5). Push the back of the condensate drain pan downward from the connection to the heat exchanger (6) and remove it from the appliance.
8. Remove the connector from the fan and the ignition unit from the gas valve.
9. Unscrew the coupling below the gas valve.
10. Unscrew the shoulder bolts from the front cover and remove this complete with gas valve and fan to the front (NB ensure that the burner, insulation plate, gas valve, gas supply and fan do not get damaged).



### CAUTION

The boiler is equipped with a non-return valve (A), positioned above the fan. Check that the valve is still in good condition and ensure the non-return valve is repositioned correctly when replacing the fan.

### 12.2 Cleaning

1. Clean the heat exchanger from top to bottom with a plastic brush or compressed air.
2. Clean the underside of the heat exchanger.
3. Clean the condensate drain pan with water.
4. Clean the condensate trap with water.

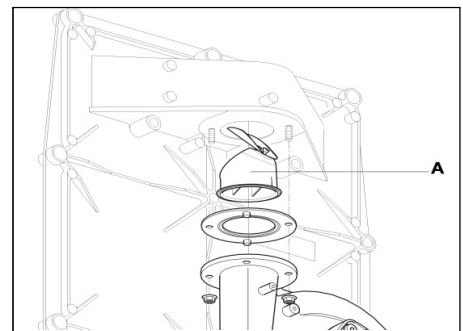
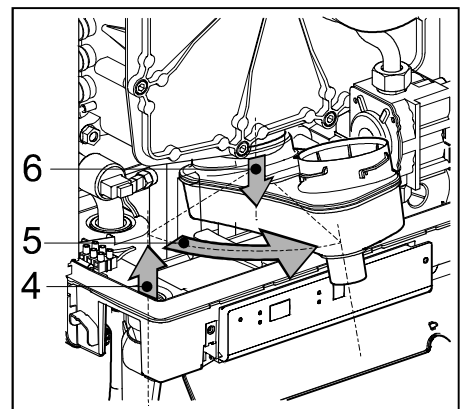
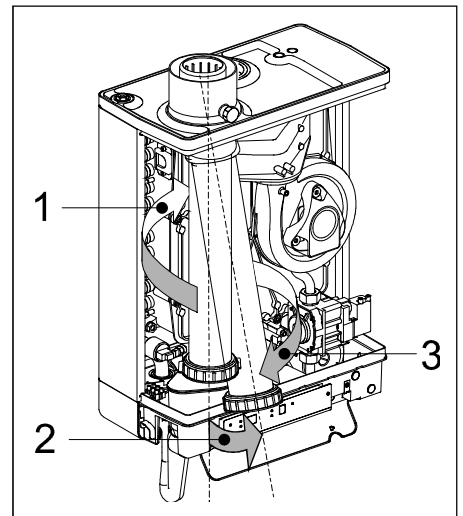
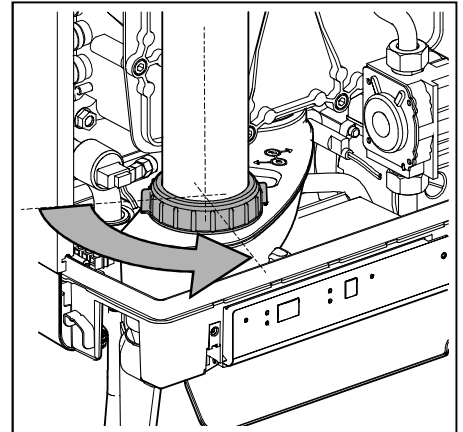

### 12.3 Assembly



#### CAUTION

When fitting the various seals check for damage, hardening, tears or hairline tears and/or discoloration. Where necessary fit a new seal. Also check whether seals are still correctly positioned.

Warranty will be void by not correctly replacing removed parts!

1. Check if there is a small layer of ceramic grease on the contact surface between the shoulder bolt and the front plate.
2. Ensure that the seal around the front cover is installed correctly. Place the front cover on the heat exchanger and secure it using the socket head screws plus serrated lock washers. Tighten the shoulder bolts equally hand-tight (10 – 12 Nm), working crosswise. See the picture for the correct sequence.  
N.B. The picture is showing a front plate with 11 shoulder bolts (Compact HRE 24 OV or, HRE 30 OV). The front plate for the Compact HRE 18 OV has 9 shoulder bolts.
3. Fit the gas connection below the gas valve.
4. Fit the connector to the fan and the ignition unit to the gas valve.
5. Fit the condensate drain by sliding on to the exchanger outlet stump (1) with the condensate trap connection still in front of the base tray. Then turn it to the left (2) and push it downwards into the condensate trap connection (3). Make sure in doing this that the back of the condensate drain pan comes to rest on the lug at the back of the base tray (A).
6. Fill the condensate trap with water and fit it to the connection below the condensate drain pan.
7. Slide the flue pipe, turning it anti-clockwise, with the top around the flue adapter, into the top cover. Insert the bottom into the condensate drain pan and tighten the coupling nut clockwise.
8. Open the gas tap and check all related gas connections
9. Check the CH and, if applicable, the water pipes for leakage.
10. Switch on the mains power.
11. Switch the appliance on with the **ⓘ** key.
12. Check the front cover, the fan connection on the front cover and the flue pipe components for leakage.
13. Check the gas/air adjustment.
14. Fit the casing, tighten the two screws left and right of the display and close the display cover.
15. Check the heating and, if applicable, the hot water supply.

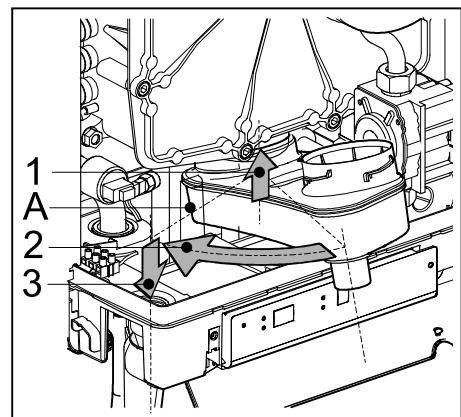
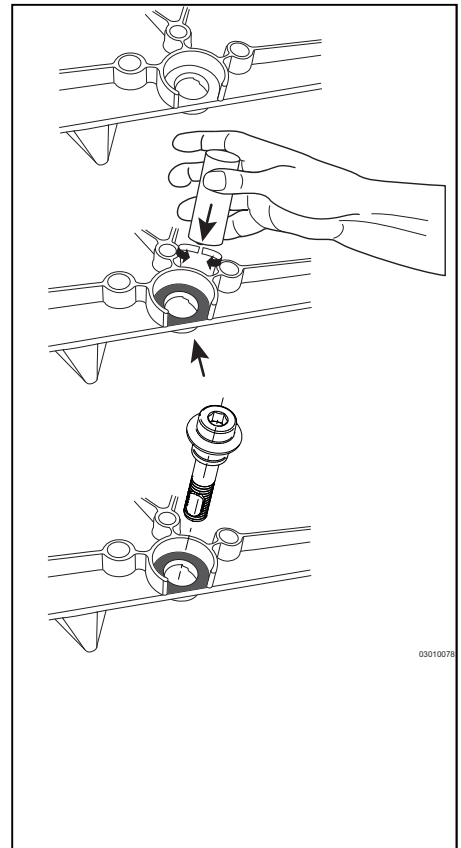

### 12.4 Combustion

During routine servicing, and after any maintenance or change of part of the combustion circuit the following must be checked:

- The integrity of the flue system and the flue seals, as described in § 8.5 and the British Standards codes of practices, specifically BS 5440.
- The integrity of the boiler combustion circuit and the relevant seals, as described in § 12.3.
- The operational (working) gas inlet pressure at maximum rate, as described in § 10.7.2.
- The combustion performance, as described in § 10.7. and § 10.8.

BS 6798: 2009 Specification for installation and maintenance of gas-fired boilers of rated input not exceeding 70 kW net advises that:

- The person carrying out a combustion measurement should have been assessed as competent in the use of a flue gas analyser and the interpretation of the results;
- The flue gas analyser used should be one meeting the requirements of BS7927 or BS-EN50379-3 and be calibrated in accordance with the analyser manufacturers' requirements, and
- Competence can be demonstrated by satisfactory completion of the CPA1 ACS assesment, which covers the use of electronic portable combustion gas analysers in accordance with BS7967, Parts 1 to 4.

Connect the flue gas analyser to the flue gas sampling point (X) and check combustion as described in § 10.7. If the CO<sub>2</sub> percentage reading of the combustion gases at low setting falls into the bandwidth stated in § 10.8 the combustion setting is correct and no further adjustment is needed. If the combustion reading falls outside the prescribed tolerance band and the integrity of the complete flue system and combustion circuit seals have been verified as well as the inlet gas pressure proceed to adjust the gas/air ratio as described in § 10.8. When the CO<sub>2</sub> level at high setting is not within the prescribed tolerance band please contact Intergas Heating.

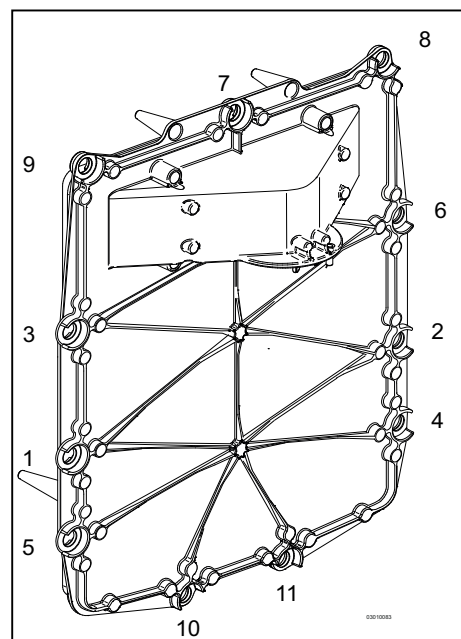

# 13 ELECTRICAL CONNECTIONS

## 13.1 Wiring diagram

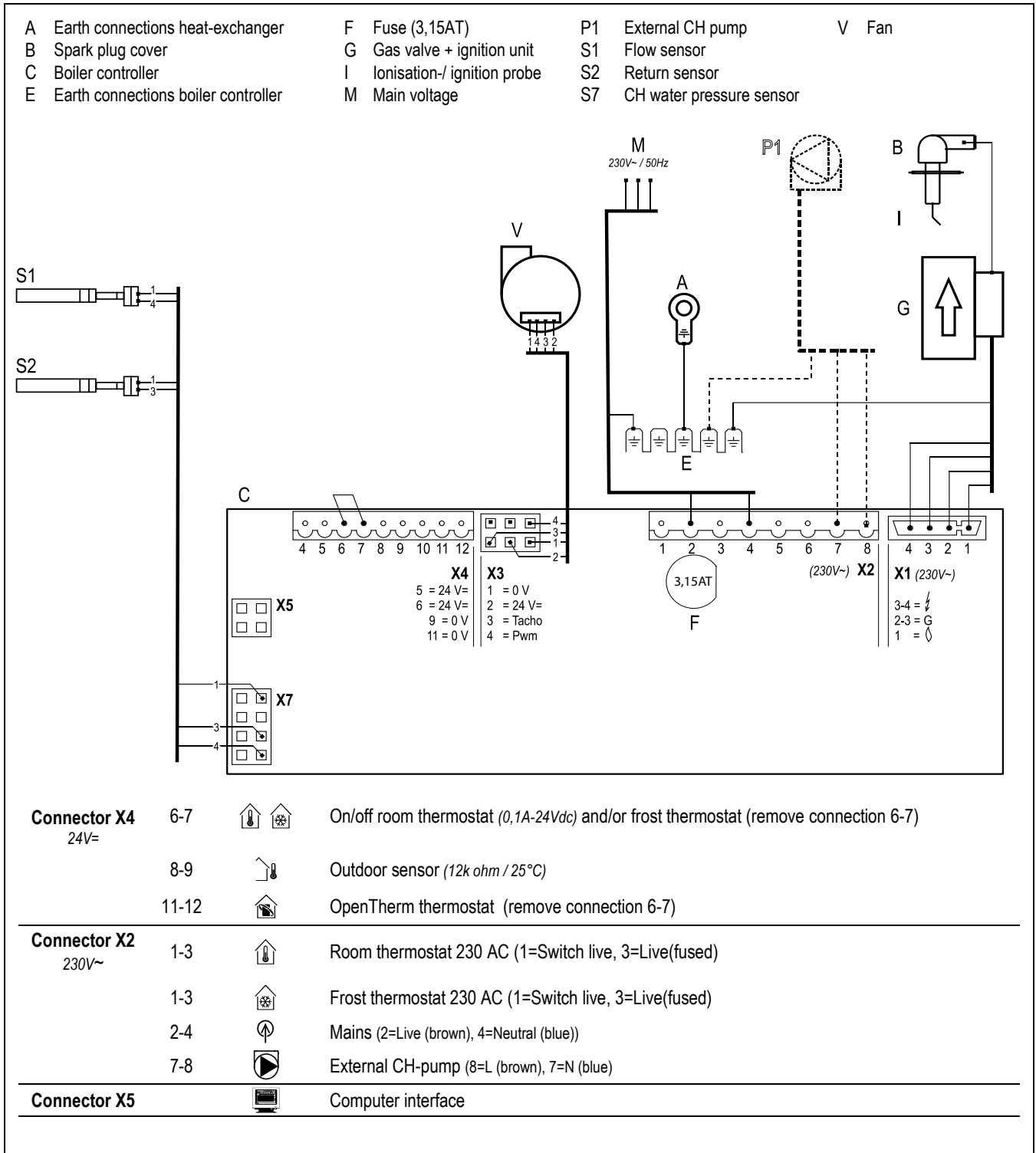

## 13.2 NTC resistances

NTC 12kOhm					
T [°C]	R[ohm]	T [°C]	R[ohm]	T [°C]	R[ohm]
-15	76020	25	12000	65	2752
-10	58880	30	9805	70	2337
-5	45950	35	8055	75	1994
0	36130	40	6653	80	1707
5	28600	45	5522	85	1467
10	22800	50	4609	90	1266
15	18300	55	3863	95	1096
20	14770	60	3253	100	952

13.3 Typical Y Plan connection

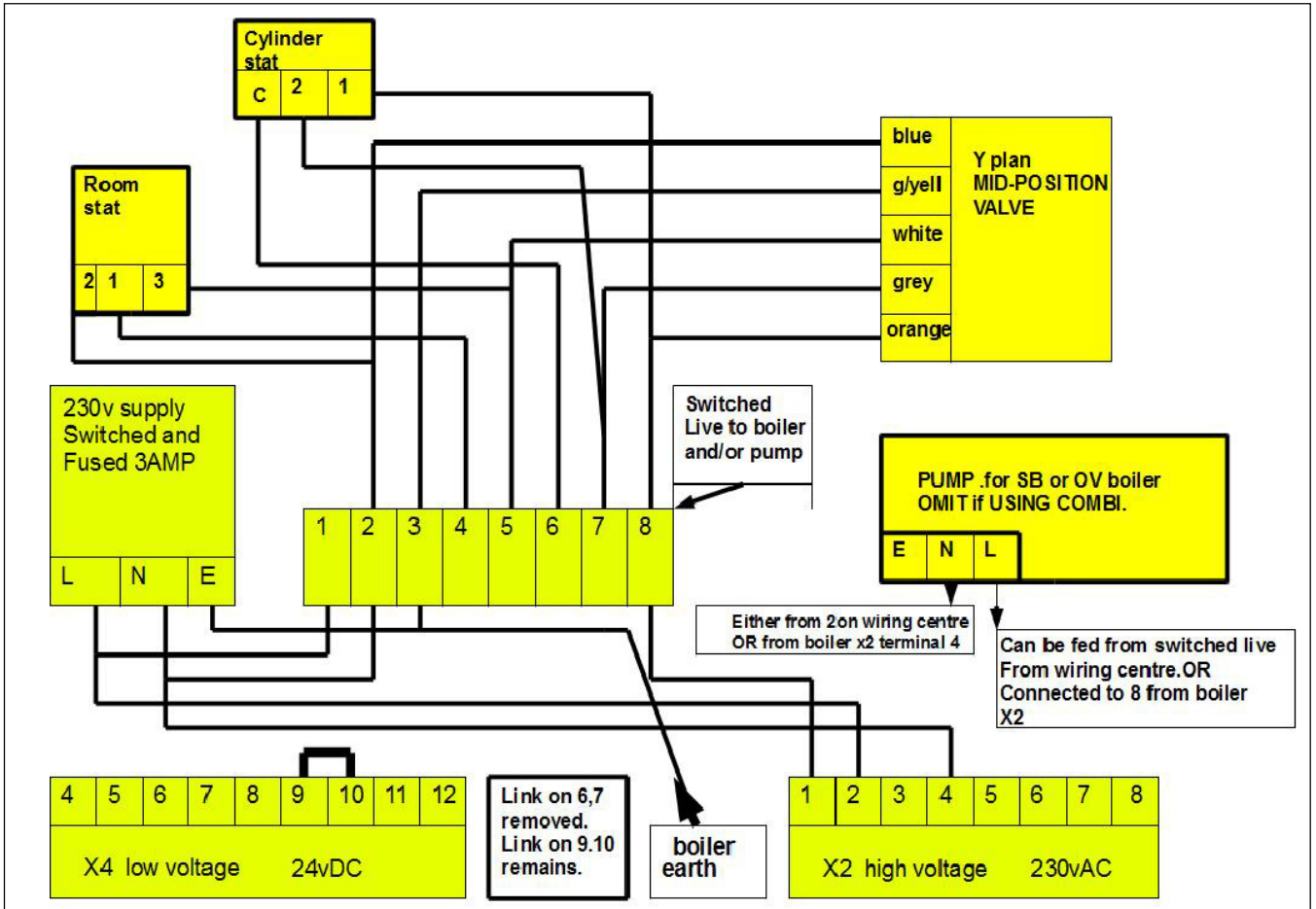

13.4 Typical S Plan connection

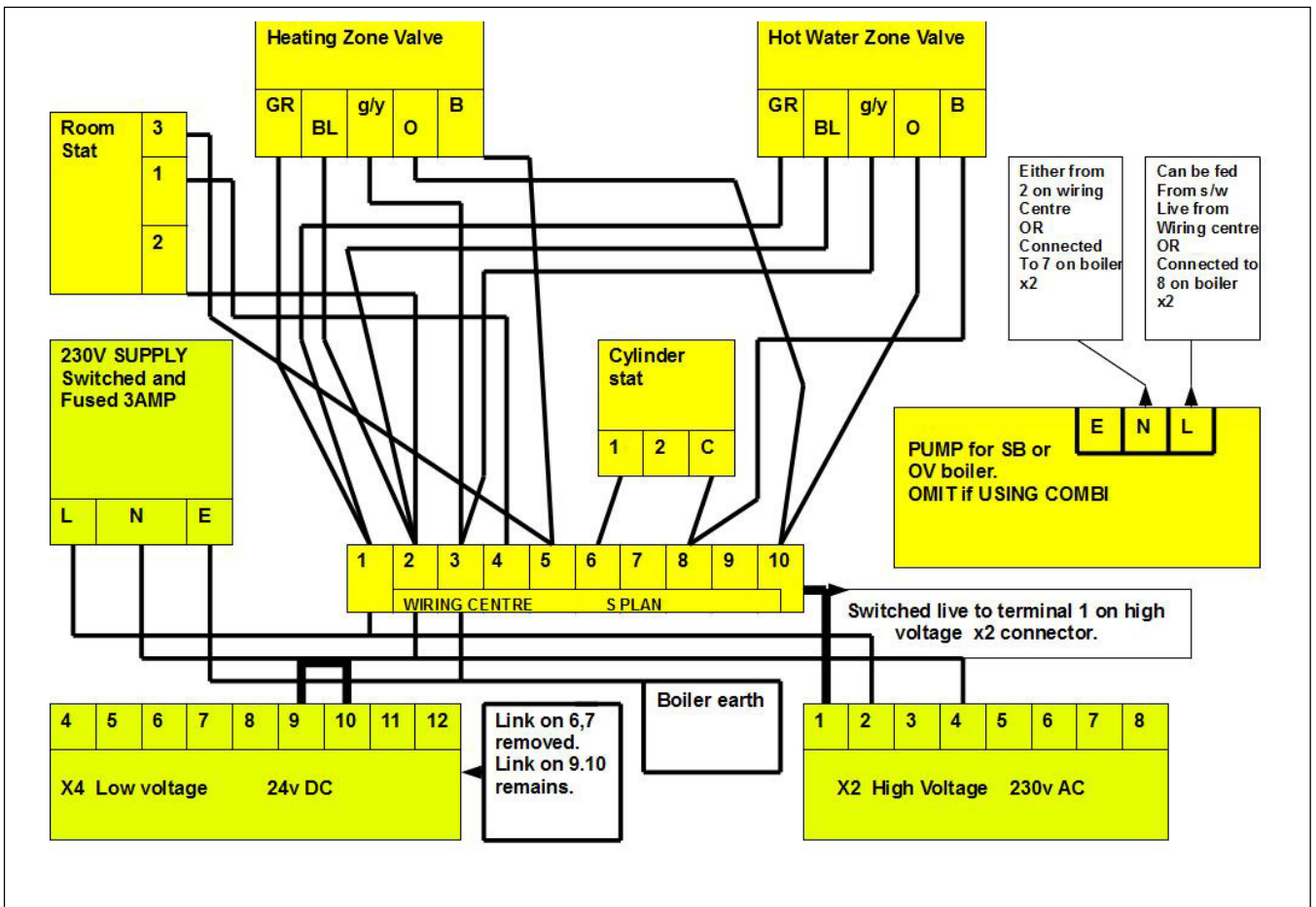

## 14 SHORT SPARES LIST

Description	Article number
Fan 24 V	074507
Temperature sensor (heat exchanger)	200117
Ignition / ionisation electrode service set	074337
Ignition cable	074607
Gas valve Siemens	801597
Ignition module	801537
Condensate trap	844187
Condensate collector	847037
Seal gas valve (inlet)	875757
O-ring gas restriction ring	875827
O-ring front plate Compact HRE OV 30	620274
O-ring front plate Compact HRE OV 24	877927
O-ring front plate Compact HRE OV 18	876467
Seal ring condensate collector (heat exchanger connection)	878147
O-ring flue pipe dia 68*4	878537
Seal ring flue pipe (outlet side)	878547
Condensate trap connection	878577
Sampling cap	847000
Boiler controller (PCB)	074448

## 15 WARRANTY CONDITIONS

1. The installer must be registered with Gas Safe, installer must complete the Benchmark Commissioning Checklist in full at the time the boiler is installed. The Benchmark must be made available and can be found at the back of the installation instructions. The Benchmark Commissioning Checklist must be retained on site by the owner/occupier for inspection during an engineers visit.
2. The boiler warranty must be registered with Intergas by either the installer or you the householder, within 30 days of the boiler being installed. For the new build properties, this must be done within 30 days of the sale being completed.  
If these conditions are not met, the warranty will not be valid.

**The product must be registered via the internet at [www.intergasheating.co.uk](http://www.intergasheating.co.uk) or on the Intergas MiREG website [www.myintergasregistration.co.uk](http://www.myintergasregistration.co.uk) or by returning the warranty card.**

3. The boiler must be serviced annually by a registered Gas Safe Engineer in accordance with manufacturer's instructions.
4. Service details must be recorded in the Benchmark Checklist or provide proof of service which must be available for inspection.
5. The cost of the annual service is not included in the warranty.

**If the above conditions are not meet this warranty will be limited to 12 months from the date of installation or date of Manufacture, as recorded on the Benchmark commissioning checklist.**



### Important

Warranty terms mentioned above are based on domestic use only. Any non-domestic applications will be covered by a 12 months warranty. Service intervals may need to be increased depending on commercial usage. For additional information please contact *Intergas Heating Ltd.*

6. Only boiler component failures are covered by the warranty. The warranty does not cover any connected system or accessories such as time switches, thermostats, motorised valves, external pumps and so on.
7. Any repair carried out under the terms of this warranty does not extend the warranty beyond its original period.
8. If the boiler breaks down, Intergas may ask you\* (Homeowner or Installer) to pay a deposit before we visit to complete the repair. We will return the deposit in full if we find a fault that is covered by the warranty. We may keep the deposit if we cannot access the property at the time we have arranged with you to visit or we find other conditions of this warranty have not been met.
9. The system must be flushed and cleansed in accordance with BS7593.
10. If any failure is caused by contaminated water in the system the engineer visit becomes chargeable.
11. All installation, non boiler or external system faults calls will be charged to the home owner/occupier.
12. Roof space installation BS6798 2009 Require a permanently fixed access ladder must service installations in lofts or attics. Adequate lighting and permanently fixed flooring must also be available.
13. Engineers will not carry out repairs if they think accessing the boiler would be a risk to Health and Safety. A responsible adult must be at the property to give our engineer access to the boiler.
14. If your boiler is in a cupboard, there must be enough room for the engineer to work (the minimum area as set out in the installation instructions). We are not responsible for removing cupboards, kitchen units, trims etc to gain access for repairs.
15. In hard water areas of 200ppm or above, appropriate protection actions must be taken in accordance with BS 7593 in line with

building regulations Part L1.

(Above 200ppm we recommend Combimate\*, Adey Electroscale or Hydroflow HS38 should be installed. 300ppm and above we recommend a Combimate\* or Water softener\* should be installed.) (\*serviceable item)

16. The central heating system must be maintained in accordance with the Benchmark Guidance on Water Treatment in Central Heating Systems & BS7593, we recommend the use of FERNOX, or ADEY inhibitors and Filters. It is important that correct concentration of water treatment is maintained for the life of the boiler, should we attend a warranty call we have the right to take a water sample. Should this fail the warranty will not be valid and will become chargeable. (BS 7593:2006)
17. If the boiler suffers a breakdown you should contact Intergas on 01527 888000 selecting option 2.  
Our normal working hours, excluding Bank Holidays are:  
8.00am – 5.00pm Monday to Friday and  
8.00am – 12.00pm Saturday mornings.



*Installers are required to carry out installation, commissioning and servicing work in accordance with the Benchmark Code of Practice which is available from the Heating and Hot Water Industry Council who manage and promote the scheme.  
Visit [www.centralheating.co.uk](http://www.centralheating.co.uk) for more information.*

## 16 CE DECLARATION

Manufacturer	Intergas Heating Ltd
Address	Unit 2 Easter Park Worcester Road Kidderminster DY11 7AR

Hereby declares that the CH appliances:

Compact HRE 30 OV  
Compact HRE 24 OV  
Compact HRE 18 OV

meets the provisions of the following directives:

- Low Voltage Directive (2014/35/EC)
- Gas Appliances Regulation (2016/426/EC)
- Boiler Efficiency Directive for new oil- and gas-fired central heating boilers (92/42/EC)
- EMC Directive (2014/30/EC)
- RED Directive (2014/53/EC)
- Ecodesign (2009/125/EG)
- Energy labelling 2010/30/EU

Stephen Zouch, March 2018

GAS BOILER SYSTEM COMMISSIONING CHECKLIST

**GAS BOILER SYSTEM COMMISSIONING CHECKLIST**

This Commissioning Checklist is to be completed in full by the competent person who commissioned the boiler as a means of demonstrating compliance with the appropriate Building Regulations and then handed to the customer to keep for future reference.

Failure to install and commission according to the manufacturer's instructions and complete this Benchmark Commissioning Checklist will invalidate the warranty. This does not affect the customer's statutory rights.

Customer name:		Telephone number:	
Address:			
Boiler make and model:			
Boiler serial number:			
Commissioned by (PRINT NAME):		Gas Safe register number:	
Company name:		Telephone number:	
Company address:			
		Commissioning date:	
<b>To be completed by the customer on receipt of a Building Regulations Compliance Certificate*</b>			
Building Regulations Notification Number (if applicable):			
<b>CONTROLS</b> (tick the appropriate boxes)			
Time and temperature control to heating	Room thermostat and programmer/timer Load/weather compensation		Programmable room thermostat Optimum start control
Time and temperature control to hot water	Cylinder thermostat and programmer/timer		Combination Boiler
Heating zone valves	Fitted		Not required
Hot water zone valves	Fitted		Not required
Thermostatic radiator valves	Fitted		Not required
Automatic bypass to system	Fitted		Not required
Boiler interlock			Provided
<b>ALL SYSTEMS</b>			
The system has been flushed and cleaned in accordance with BS7593 and boiler manufacturer's instructions			Yes
What system cleaner was used?			
What inhibitor was used?			Quantity litres
Has a primary water system filter been installed?			Yes No
<b>CENTRAL HEATING MODE</b> measure and record:			
Gas rate	m <sup>3</sup> /hr	OR	ft <sup>3</sup> /hr
Burner operating pressure (if applicable)	mbar	OR Gas inlet pressure	mbar
Central heating flow temperature			°C
Central heating return temperature			°C
<b>COMBINATION BOILERS ONLY</b>			
Is the installation in a hard water area (above 200ppm)?			Yes No
If yes, and if required by the manufacturer, has a water scale reducer been fitted?			Yes No
What type of scale reducer has been fitted?			
<b>DOMESTIC HOT WATER MODE</b> Measure and Record:			
Gas rate	m <sup>3</sup> /hr	OR	ft <sup>3</sup> /hr
Burner operating pressure (at maximum rate)	mbar	OR Gas inlet pressure at maximum rate	mbar
Cold water inlet temperature			°C
Hot water has been checked at all outlets			Yes Temperature °C
Water flow rate			l/min
<b>CONDENSING BOILERS ONLY</b>			
The condensate drain has been installed in accordance with the manufacturer's instructions and/or BS5546/BS6798			Yes
<b>ALL INSTALLATIONS</b>			
Record the following:	At max. rate:	CO ppm	AND CO/CO <sub>2</sub> Ratio
	At min. rate: (where possible)	CO ppm	AND CO/CO <sub>2</sub> Ratio
The heating and hot water system complies with the appropriate Building Regulations			Yes
The boiler and associated products have been installed and commissioned in accordance with the manufacturer's instructions			Yes
The operation of the boiler and system controls have been demonstrated to and understood by the customer			Yes
The manufacturer's literature, including Benchmark Checklist and Service Record, has been explained and left with the customer			Yes
Commissioning Engineer's Signature			
Customer's Signature			
(To confirm satisfactory demonstration and receipt of manufacturer's literature)			

\*All installations in England and Wales must be notified to Local Authority Building Control (LABC) either directly or through a Competent Persons Scheme. A Building Regulations Compliance Certificate will then be issued to the customer.



# 17 SERVICE RECORD

## SERVICE RECORD

It is recommended that your heating system is serviced regularly and that the appropriate Service Interval Record is completed.

### Service Provider

Before completing the appropriate Service Record below, please ensure you have carried out the service as described in the manufacturer's instructions. Always use the manufacturer's specified spare part when replacing controls.

<table border="1" style="width: 100%; border-collapse: collapse;"> <tr> <td colspan="2"><b>SERVICE 01</b></td> <td colspan="2">Date:</td> </tr> <tr><td colspan="4">Engineer name:</td></tr> <tr><td colspan="4">Company name:</td></tr> <tr><td colspan="4">Telephone No:</td></tr> <tr><td colspan="4">Gas safe register No:</td></tr> <tr> <td>Record:</td> <td>At max. rate:</td> <td>CO ppm</td> <td>AND CO<sub>2</sub> %</td> </tr> <tr> <td></td> <td>At min. rate: (Where Possible)</td> <td>CO ppm</td> <td>AND CO<sub>2</sub> %</td> </tr> <tr><td colspan="4">Comments:</td></tr> <tr><td colspan="4">Signature</td></tr> </table>	<b>SERVICE 01</b>		Date:		Engineer name:				Company name:				Telephone No:				Gas safe register No:				Record:	At max. rate:	CO ppm	AND CO <sub>2</sub> %		At min. rate: (Where Possible)	CO ppm	AND CO <sub>2</sub> %	Comments:				Signature				<table border="1" style="width: 100%; border-collapse: collapse;"> <tr> <td colspan="2"><b>SERVICE 02</b></td> <td colspan="2">Date:</td> </tr> <tr><td colspan="4">Engineer name:</td></tr> <tr><td colspan="4">Company name:</td></tr> <tr><td colspan="4">Telephone No:</td></tr> <tr><td colspan="4">Gas safe register No:</td></tr> <tr> <td>Record:</td> <td>At max. rate:</td> <td>CO ppm</td> <td>AND CO<sub>2</sub> %</td> </tr> <tr> <td></td> <td>At min. rate: (Where Possible)</td> <td>CO ppm</td> <td>AND CO<sub>2</sub> %</td> </tr> <tr><td colspan="4">Comments:</td></tr> <tr><td colspan="4">Signature</td></tr> </table>	<b>SERVICE 02</b>		Date:		Engineer name:				Company name:				Telephone No:				Gas safe register No:				Record:	At max. rate:	CO ppm	AND CO <sub>2</sub> %		At min. rate: (Where Possible)	CO ppm	AND CO <sub>2</sub> %	Comments:				Signature			
<b>SERVICE 01</b>		Date:																																																																							
Engineer name:																																																																									
Company name:																																																																									
Telephone No:																																																																									
Gas safe register No:																																																																									
Record:	At max. rate:	CO ppm	AND CO <sub>2</sub> %																																																																						
	At min. rate: (Where Possible)	CO ppm	AND CO <sub>2</sub> %																																																																						
Comments:																																																																									
Signature																																																																									
<b>SERVICE 02</b>		Date:																																																																							
Engineer name:																																																																									
Company name:																																																																									
Telephone No:																																																																									
Gas safe register No:																																																																									
Record:	At max. rate:	CO ppm	AND CO <sub>2</sub> %																																																																						
	At min. rate: (Where Possible)	CO ppm	AND CO <sub>2</sub> %																																																																						
Comments:																																																																									
Signature																																																																									
<table border="1" style="width: 100%; border-collapse: collapse;"> <tr> <td colspan="2"><b>SERVICE 03</b></td> <td colspan="2">Date:</td> </tr> <tr><td colspan="4">Engineer name:</td></tr> <tr><td colspan="4">Company name:</td></tr> <tr><td colspan="4">Telephone No:</td></tr> <tr><td colspan="4">Gas safe register No:</td></tr> <tr> <td>Record:</td> <td>At max. rate:</td> <td>CO ppm</td> <td>AND CO<sub>2</sub> %</td> </tr> <tr> <td></td> <td>At min. rate: (Where Possible)</td> <td>CO ppm</td> <td>AND CO<sub>2</sub> %</td> </tr> <tr><td colspan="4">Comments:</td></tr> <tr><td colspan="4">Signature</td></tr> </table>	<b>SERVICE 03</b>		Date:		Engineer name:				Company name:				Telephone No:				Gas safe register No:				Record:	At max. rate:	CO ppm	AND CO <sub>2</sub> %		At min. rate: (Where Possible)	CO ppm	AND CO <sub>2</sub> %	Comments:				Signature				<table border="1" style="width: 100%; border-collapse: collapse;"> <tr> <td colspan="2"><b>SERVICE 04</b></td> <td colspan="2">Date:</td> </tr> <tr><td colspan="4">Engineer name:</td></tr> <tr><td colspan="4">Company name:</td></tr> <tr><td colspan="4">Telephone No:</td></tr> <tr><td colspan="4">Gas safe register No:</td></tr> <tr> <td>Record:</td> <td>At max. rate:</td> <td>CO ppm</td> <td>AND CO<sub>2</sub> %</td> </tr> <tr> <td></td> <td>At min. rate: (Where Possible)</td> <td>CO ppm</td> <td>AND CO<sub>2</sub> %</td> </tr> <tr><td colspan="4">Comments:</td></tr> <tr><td colspan="4">Signature</td></tr> </table>	<b>SERVICE 04</b>		Date:		Engineer name:				Company name:				Telephone No:				Gas safe register No:				Record:	At max. rate:	CO ppm	AND CO <sub>2</sub> %		At min. rate: (Where Possible)	CO ppm	AND CO <sub>2</sub> %	Comments:				Signature			
<b>SERVICE 03</b>		Date:																																																																							
Engineer name:																																																																									
Company name:																																																																									
Telephone No:																																																																									
Gas safe register No:																																																																									
Record:	At max. rate:	CO ppm	AND CO <sub>2</sub> %																																																																						
	At min. rate: (Where Possible)	CO ppm	AND CO <sub>2</sub> %																																																																						
Comments:																																																																									
Signature																																																																									
<b>SERVICE 04</b>		Date:																																																																							
Engineer name:																																																																									
Company name:																																																																									
Telephone No:																																																																									
Gas safe register No:																																																																									
Record:	At max. rate:	CO ppm	AND CO <sub>2</sub> %																																																																						
	At min. rate: (Where Possible)	CO ppm	AND CO <sub>2</sub> %																																																																						
Comments:																																																																									
Signature																																																																									
<table border="1" style="width: 100%; border-collapse: collapse;"> <tr> <td colspan="2"><b>SERVICE 05</b></td> <td colspan="2">Date:</td> </tr> <tr><td colspan="4">Engineer name:</td></tr> <tr><td colspan="4">Company name:</td></tr> <tr><td colspan="4">Telephone No:</td></tr> <tr><td colspan="4">Gas safe register No:</td></tr> <tr> <td>Record:</td> <td>At max. rate:</td> <td>CO ppm</td> <td>AND CO<sub>2</sub> %</td> </tr> <tr> <td></td> <td>At min. rate: (Where Possible)</td> <td>CO ppm</td> <td>AND CO<sub>2</sub> %</td> </tr> <tr><td colspan="4">Comments:</td></tr> <tr><td colspan="4">Signature</td></tr> </table>	<b>SERVICE 05</b>		Date:		Engineer name:				Company name:				Telephone No:				Gas safe register No:				Record:	At max. rate:	CO ppm	AND CO <sub>2</sub> %		At min. rate: (Where Possible)	CO ppm	AND CO <sub>2</sub> %	Comments:				Signature				<table border="1" style="width: 100%; border-collapse: collapse;"> <tr> <td colspan="2"><b>SERVICE 06</b></td> <td colspan="2">Date:</td> </tr> <tr><td colspan="4">Engineer name:</td></tr> <tr><td colspan="4">Company name:</td></tr> <tr><td colspan="4">Telephone No:</td></tr> <tr><td colspan="4">Gas safe register No:</td></tr> <tr> <td>Record:</td> <td>At max. rate:</td> <td>CO ppm</td> <td>AND CO<sub>2</sub> %</td> </tr> <tr> <td></td> <td>At min. rate: (Where Possible)</td> <td>CO ppm</td> <td>AND CO<sub>2</sub> %</td> </tr> <tr><td colspan="4">Comments:</td></tr> <tr><td colspan="4">Signature</td></tr> </table>	<b>SERVICE 06</b>		Date:		Engineer name:				Company name:				Telephone No:				Gas safe register No:				Record:	At max. rate:	CO ppm	AND CO <sub>2</sub> %		At min. rate: (Where Possible)	CO ppm	AND CO <sub>2</sub> %	Comments:				Signature			
<b>SERVICE 05</b>		Date:																																																																							
Engineer name:																																																																									
Company name:																																																																									
Telephone No:																																																																									
Gas safe register No:																																																																									
Record:	At max. rate:	CO ppm	AND CO <sub>2</sub> %																																																																						
	At min. rate: (Where Possible)	CO ppm	AND CO <sub>2</sub> %																																																																						
Comments:																																																																									
Signature																																																																									
<b>SERVICE 06</b>		Date:																																																																							
Engineer name:																																																																									
Company name:																																																																									
Telephone No:																																																																									
Gas safe register No:																																																																									
Record:	At max. rate:	CO ppm	AND CO <sub>2</sub> %																																																																						
	At min. rate: (Where Possible)	CO ppm	AND CO <sub>2</sub> %																																																																						
Comments:																																																																									
Signature																																																																									
<table border="1" style="width: 100%; border-collapse: collapse;"> <tr> <td colspan="2"><b>SERVICE 07</b></td> <td colspan="2">Date:</td> </tr> <tr><td colspan="4">Engineer name:</td></tr> <tr><td colspan="4">Company name:</td></tr> <tr><td colspan="4">Telephone No:</td></tr> <tr><td colspan="4">Gas safe register No:</td></tr> <tr> <td>Record:</td> <td>At max. rate:</td> <td>CO ppm</td> <td>AND CO<sub>2</sub> %</td> </tr> <tr> <td></td> <td>At min. rate: (Where Possible)</td> <td>CO ppm</td> <td>AND CO<sub>2</sub> %</td> </tr> <tr><td colspan="4">Comments:</td></tr> <tr><td colspan="4">Signature</td></tr> </table>	<b>SERVICE 07</b>		Date:		Engineer name:				Company name:				Telephone No:				Gas safe register No:				Record:	At max. rate:	CO ppm	AND CO <sub>2</sub> %		At min. rate: (Where Possible)	CO ppm	AND CO <sub>2</sub> %	Comments:				Signature				<table border="1" style="width: 100%; border-collapse: collapse;"> <tr> <td colspan="2"><b>SERVICE 08</b></td> <td colspan="2">Date:</td> </tr> <tr><td colspan="4">Engineer name:</td></tr> <tr><td colspan="4">Company name:</td></tr> <tr><td colspan="4">Telephone No:</td></tr> <tr><td colspan="4">Gas safe register No:</td></tr> <tr> <td>Record:</td> <td>At max. rate:</td> <td>CO ppm</td> <td>AND CO<sub>2</sub> %</td> </tr> <tr> <td></td> <td>At min. rate: (Where Possible)</td> <td>CO ppm</td> <td>AND CO<sub>2</sub> %</td> </tr> <tr><td colspan="4">Comments:</td></tr> <tr><td colspan="4">Signature</td></tr> </table>	<b>SERVICE 08</b>		Date:		Engineer name:				Company name:				Telephone No:				Gas safe register No:				Record:	At max. rate:	CO ppm	AND CO <sub>2</sub> %		At min. rate: (Where Possible)	CO ppm	AND CO <sub>2</sub> %	Comments:				Signature			
<b>SERVICE 07</b>		Date:																																																																							
Engineer name:																																																																									
Company name:																																																																									
Telephone No:																																																																									
Gas safe register No:																																																																									
Record:	At max. rate:	CO ppm	AND CO <sub>2</sub> %																																																																						
	At min. rate: (Where Possible)	CO ppm	AND CO <sub>2</sub> %																																																																						
Comments:																																																																									
Signature																																																																									
<b>SERVICE 08</b>		Date:																																																																							
Engineer name:																																																																									
Company name:																																																																									
Telephone No:																																																																									
Gas safe register No:																																																																									
Record:	At max. rate:	CO ppm	AND CO <sub>2</sub> %																																																																						
	At min. rate: (Where Possible)	CO ppm	AND CO <sub>2</sub> %																																																																						
Comments:																																																																									
Signature																																																																									
<table border="1" style="width: 100%; border-collapse: collapse;"> <tr> <td colspan="2"><b>SERVICE 09</b></td> <td colspan="2">Date:</td> </tr> <tr><td colspan="4">Engineer name:</td></tr> <tr><td colspan="4">Company name:</td></tr> <tr><td colspan="4">Telephone No:</td></tr> <tr><td colspan="4">Gas safe register No:</td></tr> <tr> <td>Record:</td> <td>At max. rate:</td> <td>CO ppm</td> <td>AND CO<sub>2</sub> %</td> </tr> <tr> <td></td> <td>At min. rate: (Where Possible)</td> <td>CO ppm</td> <td>AND CO<sub>2</sub> %</td> </tr> <tr><td colspan="4">Comments:</td></tr> <tr><td colspan="4">Signature</td></tr> </table>	<b>SERVICE 09</b>		Date:		Engineer name:				Company name:				Telephone No:				Gas safe register No:				Record:	At max. rate:	CO ppm	AND CO <sub>2</sub> %		At min. rate: (Where Possible)	CO ppm	AND CO <sub>2</sub> %	Comments:				Signature				<table border="1" style="width: 100%; border-collapse: collapse;"> <tr> <td colspan="2"><b>SERVICE 10</b></td> <td colspan="2">Date:</td> </tr> <tr><td colspan="4">Engineer name:</td></tr> <tr><td colspan="4">Company name:</td></tr> <tr><td colspan="4">Telephone No:</td></tr> <tr><td colspan="4">Gas safe register No:</td></tr> <tr> <td>Record:</td> <td>At max. rate:</td> <td>CO ppm</td> <td>AND CO<sub>2</sub> %</td> </tr> <tr> <td></td> <td>At min. rate: (Where Possible)</td> <td>CO ppm</td> <td>AND CO<sub>2</sub> %</td> </tr> <tr><td colspan="4">Comments:</td></tr> <tr><td colspan="4">Signature</td></tr> </table>	<b>SERVICE 10</b>		Date:		Engineer name:				Company name:				Telephone No:				Gas safe register No:				Record:	At max. rate:	CO ppm	AND CO <sub>2</sub> %		At min. rate: (Where Possible)	CO ppm	AND CO <sub>2</sub> %	Comments:				Signature			
<b>SERVICE 09</b>		Date:																																																																							
Engineer name:																																																																									
Company name:																																																																									
Telephone No:																																																																									
Gas safe register No:																																																																									
Record:	At max. rate:	CO ppm	AND CO <sub>2</sub> %																																																																						
	At min. rate: (Where Possible)	CO ppm	AND CO <sub>2</sub> %																																																																						
Comments:																																																																									
Signature																																																																									
<b>SERVICE 10</b>		Date:																																																																							
Engineer name:																																																																									
Company name:																																																																									
Telephone No:																																																																									
Gas safe register No:																																																																									
Record:	At max. rate:	CO ppm	AND CO <sub>2</sub> %																																																																						
	At min. rate: (Where Possible)	CO ppm	AND CO <sub>2</sub> %																																																																						
Comments:																																																																									
Signature																																																																									

\*All installations in England and Wales must be notified to Local Authority Building Control (LABC) either directly or through a Competent Persons Scheme. A Building Regulations Compliance Certificate will then be issued to the customer.











## Intergas Heating Ltd

---

Intergas Heating Ltd  
Unit 2  
Easter Park  
Worcester Road  
Kidderminster  
DY11 7AR

Tel: 01527 888000  
Fax: 01384 279480  
[info@intergasheating.co.uk](mailto:info@intergasheating.co.uk)  
[www.intergasheating.co.uk](http://www.intergasheating.co.uk)

88324803

