

# **sime** **HALSTEAD** *Trio*

WALL MOUNTED FAN ASSISTED COMBINATION GAS BOILER  
G.C. NO. 47 283 01



INSTALLATION AND SERVICING INSTRUCTIONS

# CONTENTS

	Page		Page		
<b>1</b>	<b>INTRODUCTION</b>	<b>4</b>	<b>7</b>	<b>FAULT FINDING</b>	<b>23</b>
			7.1	Earth Continuity Check	23
			7.2	Short Circuit Check	23
			7.3	Polarity Check	23
			7.4	Resistance to Earth Check	23
			7.5	CH Mode-Fault Finding	24
			7.6	DHW Mode-Fault Finding	25
<b>2</b>	<b>TECHNICAL SPECIFICATIONS</b>	<b>5</b>	<b>8</b>	<b>INTERNAL WIRING DIAGRAMS</b>	<b>26</b>
2.1	General Data	5	8.1	Functional Flow Wiring Diagram	26
2.2	Exploded Diagrams	7	8.2	Illustrated Wiring Diagram	27
<b>3</b>	<b>INSTALLATION REQUIREMENTS</b>	<b>8</b>	<b>9</b>	<b>REPLACEMENT OF PARTS</b>	<b>29</b>
3.1	Statutory Requirements	8	9.1	Heat Exchanger	29
3.2	Boiler Position	8	9.2	Heat Exchanger Insulation	29
3.3	Flue Terminal Position	8	9.3	Fan Assembly	29
3.4	Ventilation Requirements	9	9.4	Main Burner	30
3.5	Gas Supply	9	9.5	Pilot Burner Assembly and Electrode	30
3.6	Electricity Supply	10	9.6	Gas Valve	30
3.7	External Controls	10	9.7	Pressure Switch	31
3.8	Water Systems - General	10	9.8	Limit Thermostat	31
3.9	Requirements for Sealed Water Systems	10	9.9	Overheat Thermostat	32
3.10	Domestic Hot Water Systems	12	9.10	CH Thermistor	32
			9.11	D.H.W. Thermistor	32
			9.12	Ignition PCB	32
<b>4</b>	<b>INSTALLING THE APPLIANCE</b>	<b>12</b>	9.13	Driver PCB	32
4.1	Unpacking the Appliance	12	9.14	Pump	33
4.2	Fixing the Wall Mounting Bracket	13	9.15	DHW Heat Exchanger	33
4.3	Hanging the Appliance	13	9.16	Divertor Valve Complete	33
4.4	Flue and Terminal Preparation	14	9.17	Divertor Valve Microswitch Assembly	33
4.5	Flue and Terminal Installation	16	9.18	C.H. Expansion Vessel	34
4.6	Water Connections	17	9.19	Summer / Winter Switch	34
4.7	Gas Connections	17	9.20	Pressure / Temperature Gauge	34
4.8	Safety Valve Connection	17	9.21	Safety Valve	34
4.9	Wiring Instructions	18	9.22	Automatic Air Vent	35
			9.23	Viewing Window	35
<b>5</b>	<b>COMMISSIONING AND TESTING</b>	<b>18</b>	9.24	DHW Expansion Vessel (If Fitted)	35
5.1	Filling The Water System	18	9.25	Time Clock	35
5.2	Commissioning The Boiler	19	9.26	Time Clock Override Switch	35
5.3	Setting The CH Input	19			
5.4	Setting The DHW Flowrate	20			
5.5	Final Checks	20			
5.6	User's Instructions	20			
<b>6</b>	<b>ROUTINE SERVICING INSTRUCTIONS</b>	<b>21</b>	<b>10</b>	<b>REPLACEMENT PARTS</b>	<b>36</b>

## 1 INTRODUCTION

The Sime Halstead Combi 30/90 is a fully automatic, wall mounted, fan assisted balanced flue combination boiler.

The appliance is range rated to provide central heating outputs of between 9.7kW (33,000Btu/h) and 23.4kW (80,000Btu/h) with instantaneous domestic hot water priority at outputs between 8.79kW (30,000Btu/h) and 26.4kW (90,000 Btu/h). Heat output is varied according to demand by the modulating gas control on both DHW and CH.

The appliance is supplied with a concentric air and flue duct suitable for flue lengths of upto 0.83m (32 $\frac{1}{2}$ in) although extension duct kits are available and may be used upto a flue length of 2.4m (94 $\frac{1}{2}$ in). The combined flue and air duct can exit the boiler from either side or from the rear of the appliance. A vertical extension and additional flue elbow may be fitted (see separate specification sheet for details).

The boiler is designed for use with sealed primary water systems and is supplied fully assembled and incorporates a circulation pump, diverter valve, pressure and temperature gauge, safety valve and CH expansion vessel. All service connections have isolation valves, and a DHW expansion vessel is available as an optional extra if required. (Part No 62451)

If the wall thickness is less than 0.5m (19in) the appliance can be installed from inside the room without access to the external wall although a wall liner is required. This is available as an optional extra, and full details are given in section 4.

A time clock and override switch is fitted as standard equipment, and the boiler may be used with a 24V room thermostat. (A 240V room thermostat may be fitted if a 24V model is not available, but its sensitivity will be inferior. - Refer to section 3.7 for details.)

If the boiler is sited in a position where the temperature could fall below 2 °C, we strongly recommend fitting a frost thermostat protection device. A suitable kit is available from your stockist.

The Sime Halstead Combi features an attractive white enamelled casing with a recessed control fascia panel.

## 2 TECHNICAL SPECIFICATIONS

### 2.1 GENERAL DATA

Performance data

Nominal Boiler Ratings (2 minutes after lighting)

MODE	OUTPUT		INPUT		BURNER PRESSURE	
	kW	(Btu/h)	kW	(Btu/h)	mbar	(inwg)
CENTRAL HEATING RANGE	9.7	(33,000)	13.8	(47,000)	1.9	(0.8)
	10.6	(36,000)	14.8	(50,400)	2.2	(0.9)
	12.3	(42,000)	16.8	(57,300)	3.1	(1.2)
	14.1	(48,000)	18.9	(64,500)	4.1	(1.6)
	15.8	(54,000)	20.9	(71,300)	5.1	(2.0)
	17.6	(60,000)	22.9	(78,100)	6.3	(2.5)
	19.3	(66,000)	24.8	(84,700)	7.5	(3.0)
	21.1	(72,000)	26.7	(91,100)	8.7	(3.5)
	23.4	(80,000)	29.3	(100,000)	10.4	(4.1)
DHW. Max ONLY Min (Modulation)	26.4 8.8	(90,000) (30,000)	32.6 12.5	(111,200) (42,600)	12.9 1.5	(5.2) (0.6)

Approximate DHW Flowrate 45°C Temperature rise = 8.4 l/min (1.9gpm)  
 Approximate DHW Flowrate 40°C Temperature rise = 9.5 l/min (2.1gpm)  
 Approximate DHW Flowrate 35°C Temperature rise = 10.8 l/min (2.4gpm)

### General specifications

Main Burner Injectors	No off	13	
	Dia	1.3mm	
Water capacity	l (Galls)	2.3	(1/2)
Minimum CH water flow	l/min (gpm)	22	(5)
Minimum DHW water flow	l/min (gpm)	2.81	(0.62)
Minimum static head	bar (psi)	0.5	( 7.3)
Maximum static head	bar (psi)	3	(43.5)
Minimum DHW Pressure	bar (psi)	0.9	(13.0)
Maximum DHW Pressure	bar (psi)	7.0	(102)
Empty weight	kg (lb)	48	(106)
Max lift weight	kg (lb)	45	( 99)
Total weight (Full)	kg (lb)	50	(110)
Electrical Supply	220 - 240 Volts ~ 50 Hz,	Fused at 3A.	
Internal Fuses	Line : F1.6A,	PCB : T100mA	
Max Power Consumption	Watts	150	
Max Gas Consumption DHW	m³/h (ft³/h)	3.10	(109)
Max Gas Consumption CH	m³/h (ft³/h)	2.8	( 99)
Max Working Temperature	°C (F)	85	(180)
Integral expansion vessel capacity	l (gall)	7	(1.5)

Flue lengths Subtract desired side clearances (if applicable) to determine Available Wall Thickness.

Standard Flue kit:

Rear Outlet	745mm	(29 <sup>1</sup> / <sub>4</sub> in)
L.H. Side Outlet	690mm	(27 <sup>1</sup> / <sub>4</sub> in)
R.H. Side Outlet	630mm	(24 <sup>3</sup> / <sub>4</sub> in)

Standard Flue plus One Extension Duct kit.

Rear Outlet	1560mm	(61 <sup>1</sup> / <sub>2</sub> in)
L.H. Side Outlet	1505mm	(59 <sup>1</sup> / <sub>4</sub> in)
R.H. Side Outlet	1445mm	(56 <sup>3</sup> / <sub>4</sub> in)

Standard Flue plus Two Extension Duct kits.

Rear Outlet	2375mm	(93 <sup>1</sup> / <sub>2</sub> in)
L.H. Side Outlet	2320mm	(91 <sup>1</sup> / <sub>4</sub> in)
R.H. Side Outlet	2260mm	(89 in)

Overall appliance dimensions and connection sizes

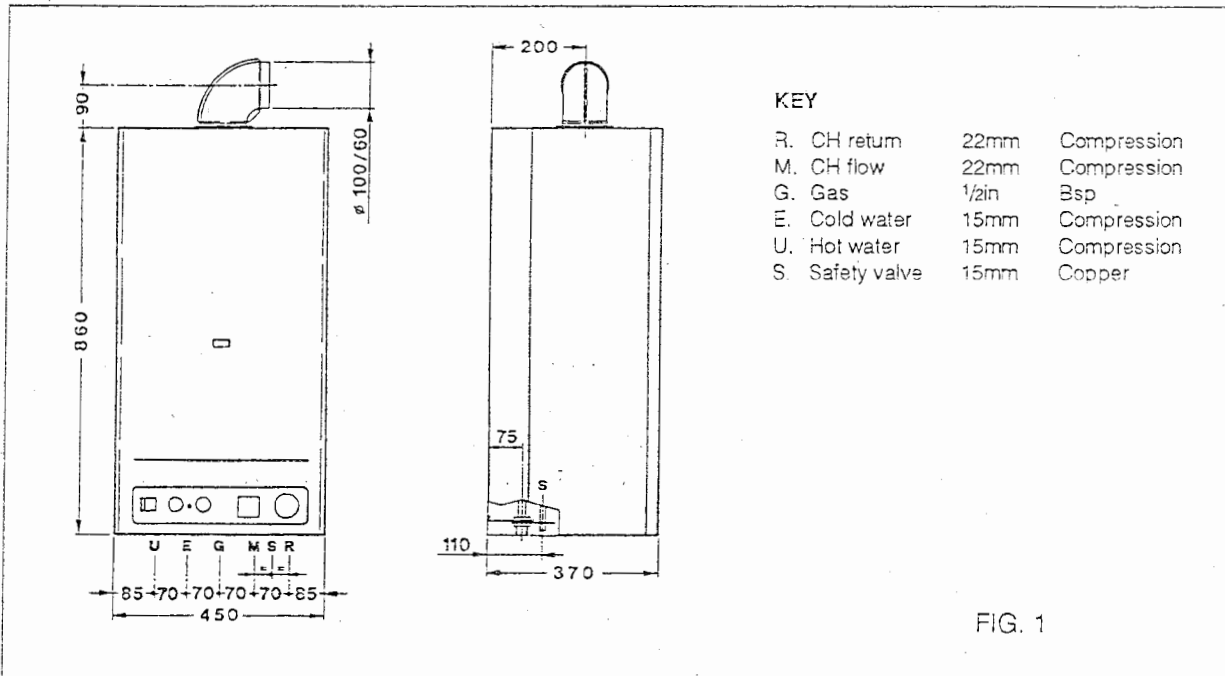

Minimum clearances

The following minimum clearances must be maintained for installation and servicing.

Above the appliance casing	200 mm	8 in
At the R.H.S	90 mm	3 <sup>1</sup> / <sub>2</sub> in
At the L.H.S	5 mm	1/4 in
Below the appliance casing	200 mm	8 in
In front of the appliance.	450 mm	18 in

## 2.2 EXPLODED DIAGRAMS

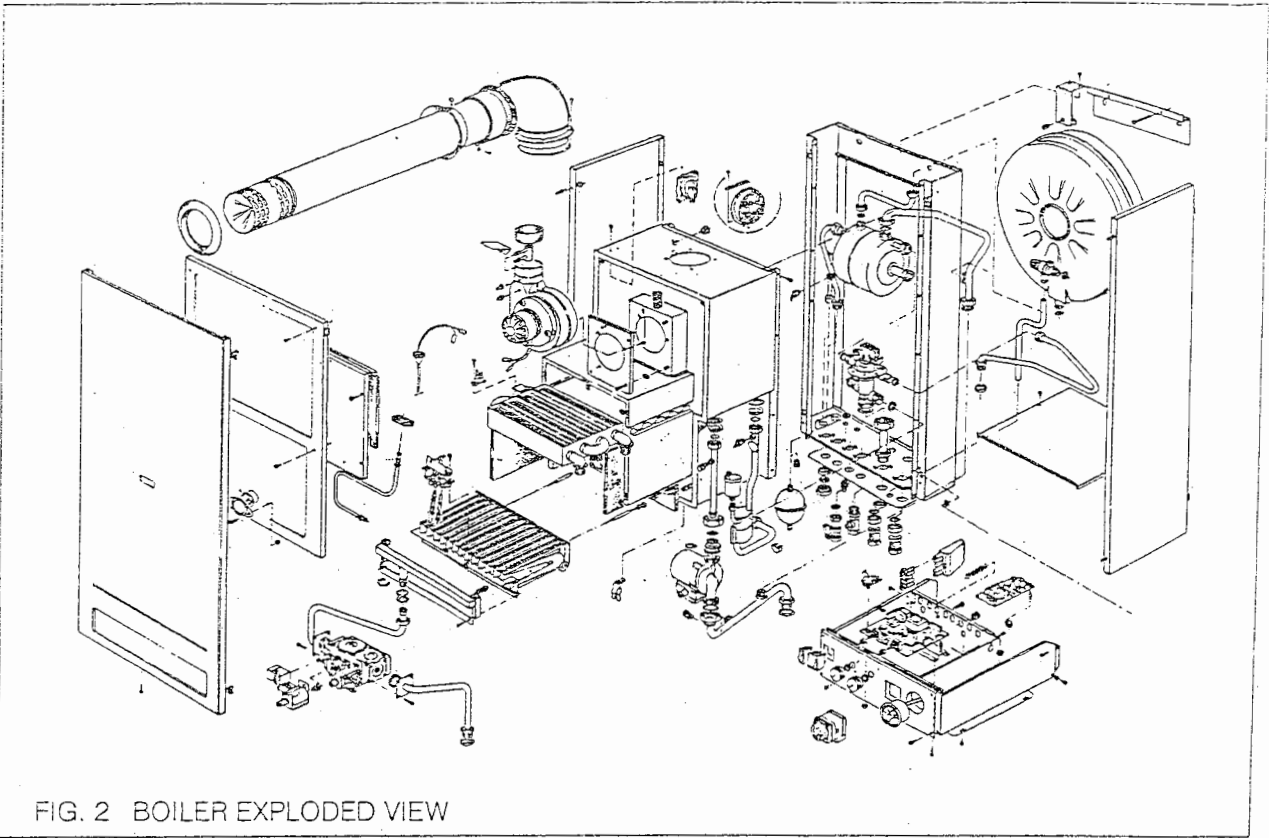

FIG. 2 BOILER EXPLODED VIEW

FIG. 3 HYDRAULIC CIRCUIT

### KEY

- 1 Air Pressure Switch
- 2 Fan
- 3 Flue Hood
- 4 Primary Heat Exchanger
- 5 Combustion Chamber
- 6 C.H. Expansion Vessel
- 7 Divertor Valve
- 8 D.H.W. Heat Exchanger (Calorifier)
- 9 Multifunctional Gas Control
- 10 Safety Valve
- 11 Combined Pressure & Temperature Gauge
- 12 Drain Cock
- 13 Circulating pump
- 14 Automatic Air Vent
- 15 D.H.W. Expansion Vessel (Optional)
- 16 D.H.W. Isolation Valve
- 17 Gas Cock
- 18 C.H. Isolation Valves
- 19 Manual Air Vent

### CONNECTIONS

- A Domestic Hot Water Outlet
- B Domestic Cold Water Inlet
- C Gas Connection
- D Central Heating Flow
- E Safety Valve discharge pip
- F Central Heating Return

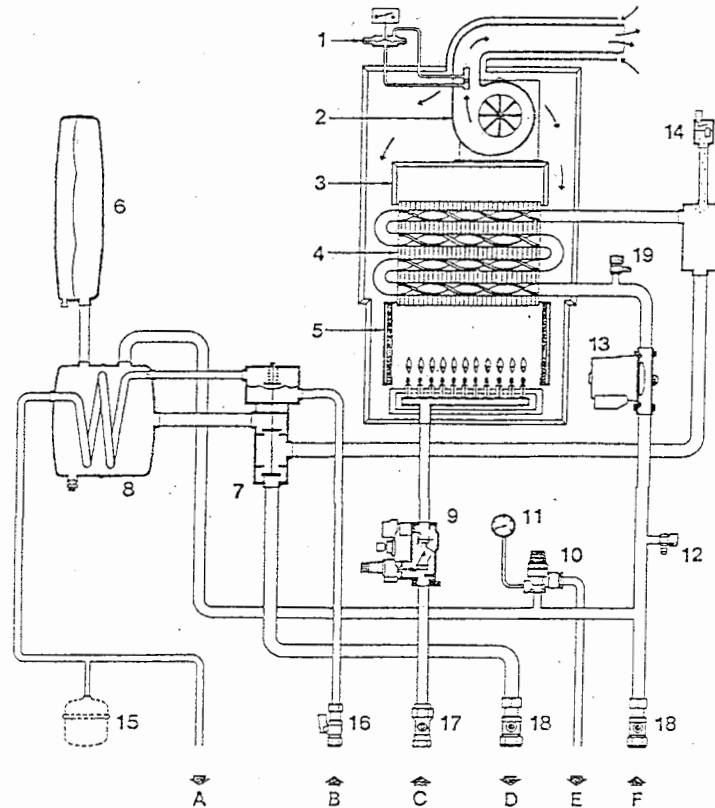

### 3 INSTALLATION REQUIREMENTS

#### 3.1 STATUTORY REQUIREMENTS

##### GAS SAFETY (INSTALLATION AND USE) REGULATIONS 1984.

It is the law that all gas appliances are installed by a competent person, in accordance with the above regulations. Failure to install appliances correctly could lead to prosecution. It is in your own interest, and that of safety, to ensure that the law is complied with.

In addition to the above regulations, this appliance must be installed in accordance with the current IEE Wiring Regulations, local building regulations, the Building Standards (Scotland) and bye laws of the local water undertaking.

It should also be in accordance with the relevant recommendations in the current editions of the following British Standards and Codes of Practice: BS5449, BS5546, BS5440:1, BS5440:2, BS6798, BS6891, and BG.DM2

**IMPORTANT NOTE:** *Manufacturer's instructions must NOT be taken in any way as over-riding statutory obligations.*

#### 3.2 BOILER POSITION

In siting the combination boiler, the following limitations MUST be observed:

- a) The boiler is not suitable for external installation. The position selected for installation should be within the building, unless otherwise protected by a suitable enclosure, and MUST allow adequate space for installation, servicing, and operation of the appliance, and for air circulation around it. (Section 2.3)
- b) This position MUST allow for a suitable flue termination to be made. The combination boiler must be installed on a flat vertical wall which is capable of supporting the weight of the appliance, and any ancillary equipment.
- c) If the combination boiler is to be fitted in a timber framed building it should be fitted in accordance with the British Gas publication Guide for Gas Installations In Timber Frame Housing, Reference DM2. If in doubt, advice must be sought from the Local Gas Region.
- d) If the appliance is installed in a room containing a bath or shower, any electrical switch or control utilising mains electricity must be so situated that it cannot be touched by a person using the bath or shower. Attention is drawn to the requirements of the current I.E.E. Wiring Regulations, and in Sco-

otland the electrical provisions of the Building Regulations applicable in Scotland.

- e) A compartment used to enclose the appliance MUST be designed and constructed specifically for this purpose. An existing cupboard, or compartment, may be used provided it is modified accordingly.
- f) Where installation will be in an unusual location, special procedures may be necessary. BS 6798 gives detailed guidance on this aspect.

#### 3.3 FLUE TERMINAL POSITION

Detailed recommendations for flue installation are given in BS 5440:1. The following notes are for general guidance.

- a) The boiler MUST be installed so that the terminal is exposed to the external air.
- b) It is important that the position of the terminal allows free passage of air across it at all times.
- c) It is ESSENTIAL TO ENSURE, in practice that products of combustion discharging from the terminal cannot re-enter the building, or any other adjacent building, through ventilators, windows, doors, other sources of natural air infiltration, or forced ventilation / air conditioning. If this does occur, the appliance MUST be turned OFF IMMEDIATELY and the Local Gas Region consulted.
- d) The minimum acceptable dimensions from the terminal to obstructions and ventilation openings are specified in Fig. 4.
- e) If the terminal discharges into a pathway or passageway check that combustion products will not cause nuisance and that the terminal will not obstruct the passageway.
- f) Where the lowest part of the terminal is fitted less than 2m (78ins) above ground, above a balcony or above a flat roof to which people have access, the terminal MUST be protected by a purpose designed guard. Terminal guards are available from Quinnell, Barrett, and Quinnell, Old Kent Road, London. State model C2, (G.C. Part No 382946).
- g) Where the terminal is fitted within 850mm (34in) of a plastic or painted gutter, or 450mm (18in) of painted eaves, an aluminium shield at least 1500mm (59in) long must be fitted to the underside of the painted surface.
- h) The air inlet / flue outlet duct MUST NOT be closer than 25mm (1in) to combustible material.

- i) In certain weather conditions the terminal may emit a plume of steam. This is normal but positions where this would cause a nuisance should be avoided.

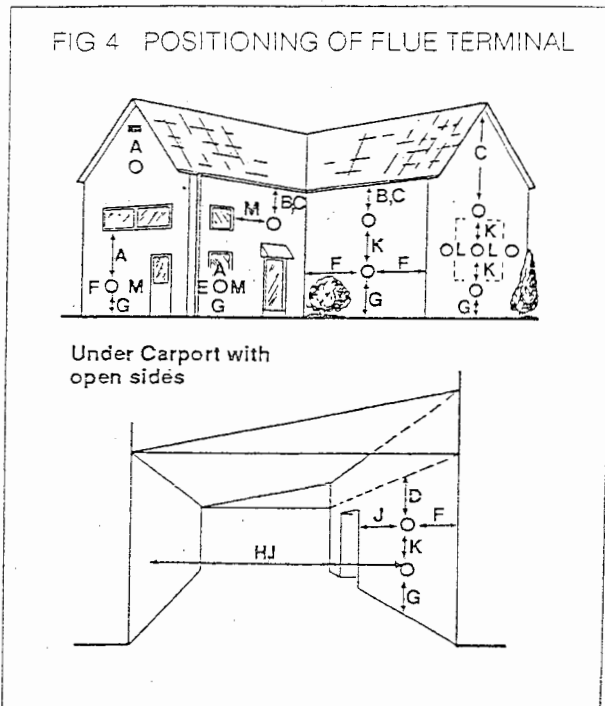

Terminal Position	Minimum Spacing
A Directly below an openable window, air vent or any other ventilation opening	300mm (12in)
B Below guttering, drain pipes or soil pipes	75mm (3in)
C/D Below eaves, balconies or carport roof	200mm (8in)
E From vertical drain pipes or soil pipes	75mm (3in)
F From internal or external corners	300mm (12in)
G Above adjacent ground, roof or balcony level	300mm (12in)
H From a surface facing the terminal	600mm (24in)
I From a terminal facing the terminal	1200mm (48in)
J From an opening in the carport (eg door, window) into dwelling)	1200mm (48in)
K Vertically from a terminal on the same wall	1500mm (60in)
L Horizontally from a terminal on the same wall	300mm (12in)
M Adjacent to opening	300mm (12in)

### 3.4 VENTILATION REQUIREMENTS

Detailed recommendations for air supply are given in BS 5440:2.

The following notes are for general guidance.

- a) It is not necessary to have a purpose provided air vent in the room or internal space in which the appliance is installed.
- b) If the boiler is to be installed in a cupboard or compartment, permanent air vents are required for cooling purposes in the cupboard or compartment at both high and low levels. Both air vents must communicate with either the same internal room / space or be on the same wall to external air. The following table gives the minimum effective areas of the vents.

Position of air vent	Air from room / int. space cm <sup>2</sup> (in <sup>2</sup> )	Air direct from outside. cm <sup>2</sup> (in <sup>2</sup> )
HIGH LEVEL	293 (48)	147 (24)
LOW LEVEL	293 (48)	147 (24)

### 3.5 GAS SUPPLY

- a) The Local Gas Region should be consulted at the installation planning stage in order to establish the availability of an adequate supply of gas.
- b) An existing service pipe **MUST NOT** be used without prior consultation with the Local Gas Region.
- c) A gas meter can only be connected by the Local Gas Region or by a Local Gas Region Contractor.
- d) An existing meter should be of sufficient size to carry the maximum boiler input plus the demand of any other installed appliance. BS 6891: 1988  
The gas required for the boiler is  
3.1m<sup>3</sup>/h (109ft<sup>3</sup>/h)
- e) The governor at the meter must give a constant outlet pressure of 20 mbar (8 in.wg) when the appliance is running.
- f) The gas supply line should be purged.

**WARNING:** Before purging open all doors and windows, also extinguish any cigarettes, pipes, and any other naked lights.



- g) The complete installation must be tested for gas soundness.
- h) It is important to ensure an adequate gas supply to the appliance. No more than 3m of 15mm pipe should be used. Where the supply exceeds 3m the pipe should be suitably sized only reducing to 15mm for the last 3m prior to the appliance.

### 3.6 ELECTRICITY SUPPLY

- a) Wiring external to the appliance must be in accordance with the current I.E.E. Wiring Regulations and any local regulations which apply.
- b) The mains cable must be at least 0.75mm (24/0.2mm) PVC insulated to BS6500 table 16.)
- c) THIS APPLIANCE MUST BE EARTHED. (Failure to do so may result in appliance malfunction.)
- d) The method of connection to the mains supply must facilitate complete electrical isolation of the appliance. Either a 3A Fused three pin plug and unswitched shuttered socket outlet, both complying with BS1363, or a 3A fused double pole switch having a 3mm contact separation in both poles and serving only the boiler (and its external controls) may be used.

### 3.7 EXTERNAL CONTROLS

If it is desired, a 24V room thermostat may be wired to the appliance between terminals 40 and 41 in the mains connector plug. Refer to section 4.9 'Wiring instructions'. The voltage between terminals 40 and 41 is 24V, hence for satisfactory operation of the compensating resistor in the thermostat it is necessary to use a 24V room thermostat. A mains room thermostat can be used, but the compensator would not function correctly, hence the room temperature swing would be greater.

### 3.8 WATER SYSTEMS - GENERAL

- a) This appliance is designed for connection to sealed central heating water systems.
- b) Check that the mains water pressure is sufficient to produce the required DHW flow rate, but does not exceed the maximum DHW pressure (Section 2.1). If necessary, a pressure reducing valve must be fitted to the mains supply before the DHW inlet connection.

### 3.9 REQUIREMENTS FOR SEALED WATER SYSTEMS.

The heating system design should be based on the following information:

- a) The available pump head is given in Fig. 5.

The type of pump fitted is easily identified after removal of the front panel.

- b) A minimum flow rate corresponding to a heating differential of 11°C must be obtained at all times.
- c) A heating by-pass should be fitted to ensure condition (b) is satisfied. If thermostatic radiator valves are to be installed, at least one radiator should be without a thermostatic valve (usually the bathroom radiator).
- d) A sealed system must only be filled by a competent person using one of the approved methods shown in Fig. 7. The system design should incorporate the connections appropriate to one of these methods.
- e) The following paragraphs outline the specifications of the items fitted to the boiler.

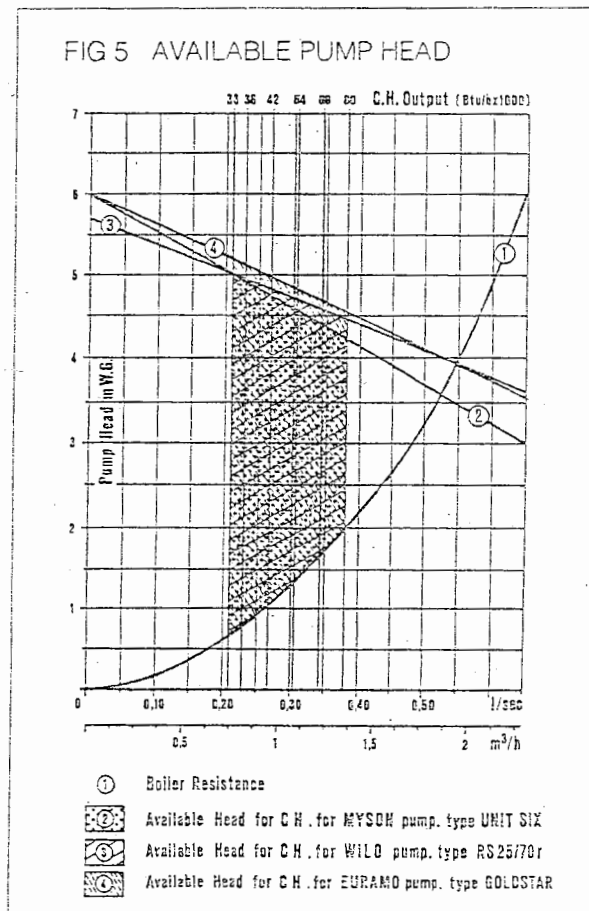

### Pump

The available head shown in fig. 5 is that in excess of the appliance hydraulic resistance, i.e. that available for the system at any given heating load up to 23.4 kW (80,000 Btu/h). Never reduce the pump speed below maximum as this will reduce DHW output. The pump speed is indicated on the side of the pump speed selector switch. (If fitted).

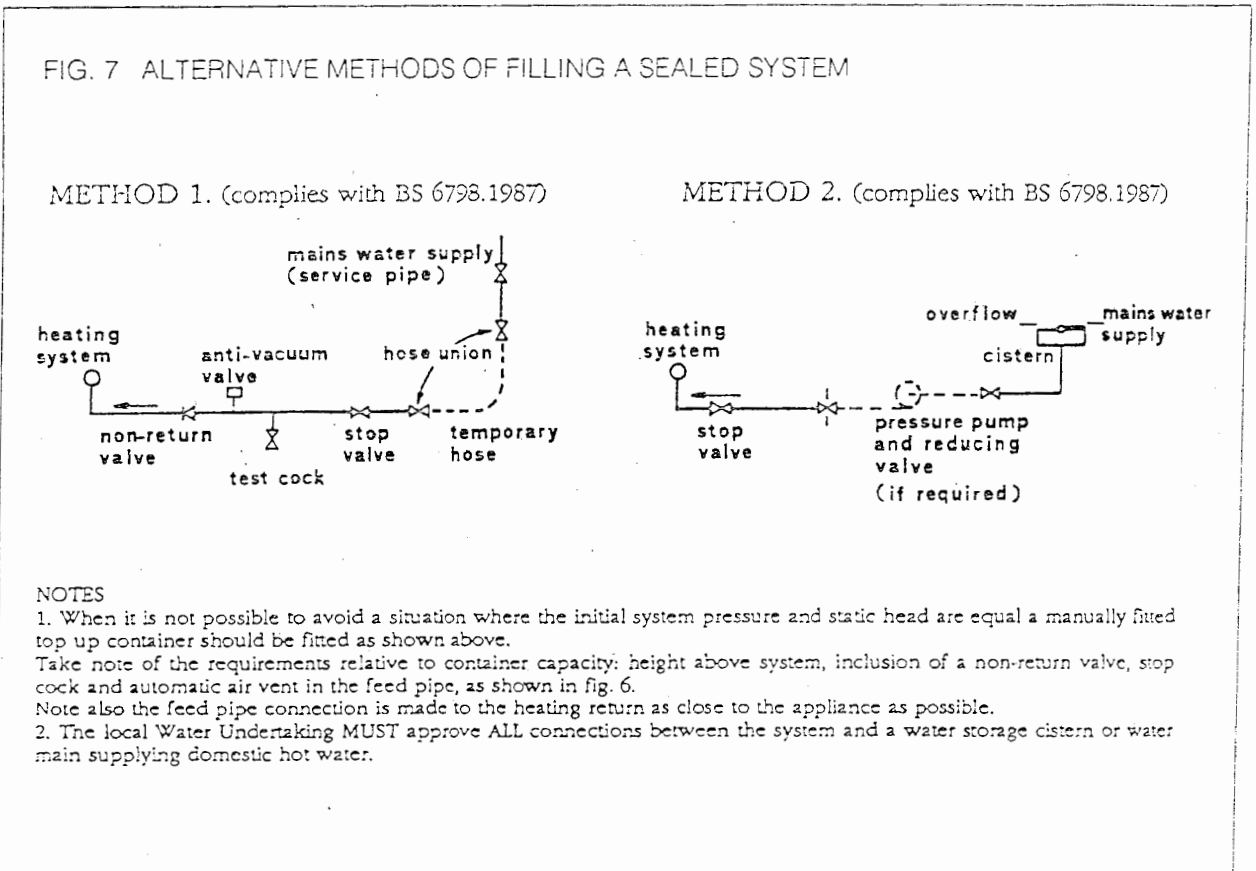
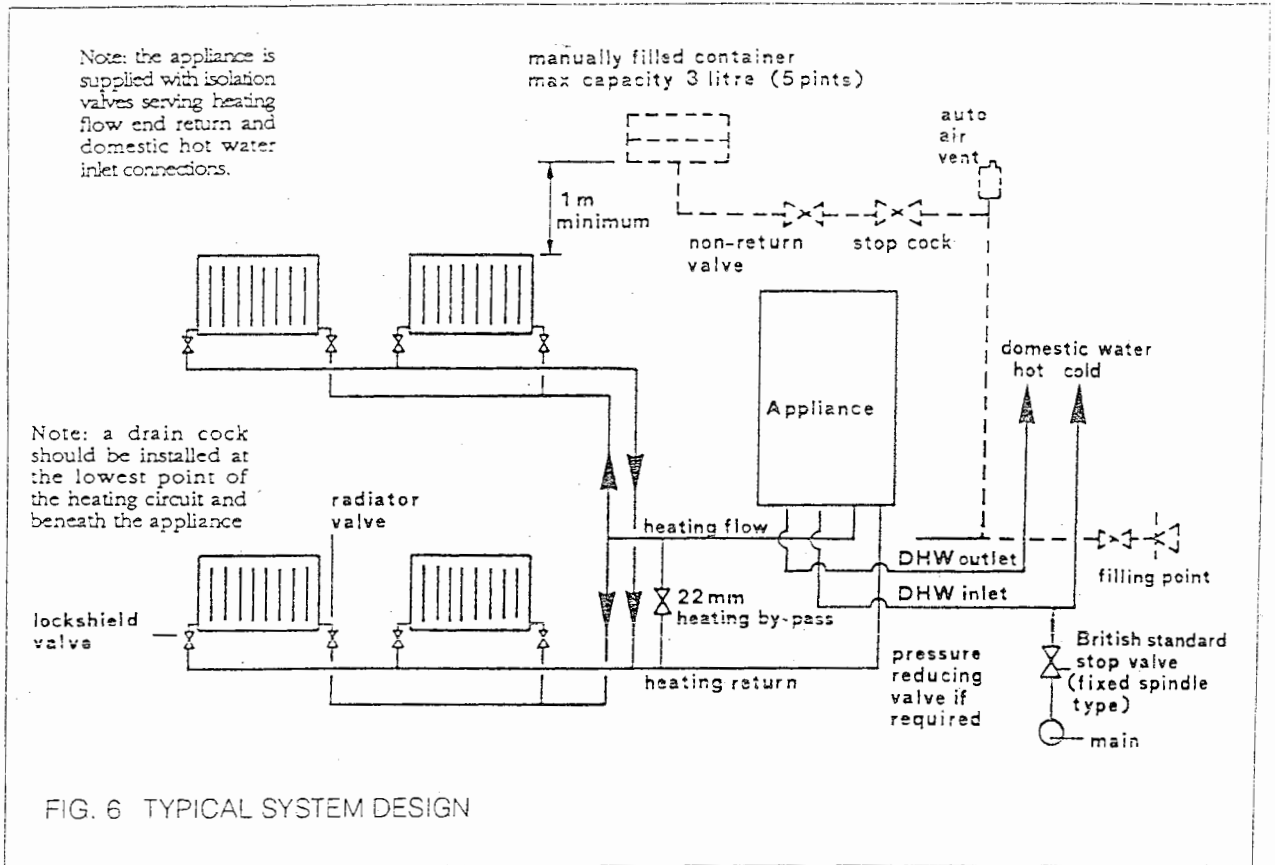

### System Volume (Total Water Content)

The following table gives the maximum system volume that the integral 7 litre expansion vessel can sustain under different charge pressure conditions. If the system volume exceeds that shown, an additional expansion vessel must be fitted and connected to the heating system primary return pipe as close as possible to the appliance.

Vessel charge and initial system pressure	bar psi	0.5 7.3	1.0 14.5	1.5 21.8
Total water content of system using 7 l (1.54 gal) capacity expansion vessel supplied with appliance	l gal	87 18.5	64 14.0	44 9.7
For systems having a larger capacity MULTIPLY the TOTAL system capacity in litres (gallons) by the factor to obtain the TOTAL MINIMUM expansion vessel capacity required litres (gallons)		.0833	.109	.156

if an extra vessel is required, ensure that the total capacity of both vessels is adequate. Further details are available in the current issues of BS5449 and BS6798.

*NOTE: If the pressure gauge indicates 2.65 bar or greater when the appliance is at maximum temperature with all radiators in circulation an extra expansion vessel is required.*

### Pressure Gauge

A combined pressure / temperature gauge is situated on the appliance fascia panel.

### Safety Valve

A safety valve set at 3 bar (43.5 psi) is fitted to the appliance and a discharge pipe is routed to outside of the appliance. This discharge pipe should be extended to terminate safely away from the appliance and where a discharge would not cause damage to persons or property but would be detected. The pipe should be able to withstand boiling water, be a minimum of 15mm in diameter, and not include any horizontal runs prone to freezing.

## 3.10 DOMESTIC HOT WATER SYSTEMS

- The authority of the local Water Company should be obtained before the appliance is connected to the cold water mains supply. Check that the mains supply pressure is within the prescribed limits (Section 2.1). If necessary, a pressure reducing valve should be fitted (Section 3.8).
- The final 600mm (24in) of the mains supply pipe to the boiler must be copper.
- A maximum DHW flow rate of 11 l/m (2.4gpm) is recommended. Higher flow rates will not damage the appliance but may lower the water temperature below an acceptable level.
- If the appliance is installed in an area where

the temporary hardness of the water supply is high, say over 150ppm, the fitting of an in line scale inhibitor may be an advantage. Consult the Local Water Undertaking if in doubt.

- Devices capable of preventing the flow of expansion water
  - e.g. non-return valves and/or loose-jumpered stop cocks
  - should not be fitted unless separate arrangements are made for expansion water.
- If a non-return valve is fitted in the incoming water supply - e.g. in line with a scale inhibitor then the optional DHW expansion vessel MUST be obtained and fitted at the connection provided in the domestic hot water circuit within the casing of the appliance (section 4.6.2.).
- For specific information relating to fittings (eg. Showers, washing machines etc) suitable for connection in the DHW circuit, consult the Local Water Undertaking, however the following information is given for guidance:

### Domestic hot/cold water supply taps and mixing taps

All equipment designed for use at mains water pressure is suitable.

### Showers

Any mains pressure shower is suitable, but if the unit has a loose head which may become immersed in bath water either an anti-syphonage device must be fitted, or the length of the flexible hose must be reduced so that it cannot fall closer than 13mm (1/2 in) to the top of the bath.

### Bidets

Providing that the appliance is of the over-rim flushing type, the outlets are shrouded and it is impossible to attach a temporary hand held spray, no anti syphonage device is necessary.

## 4 INSTALLING THE APPLIANCE

### 4.1 UNPACKING THE APPLIANCE

The standard appliance is supplied in two separate cardboard cartons. In addition up to two extension duct kits (Part No 80848.00) may be used. If the appliance is to be installed without access to the outside wall, the wall liner (Part No 60342.12) will also be required. Unpack each carton and check the contents against the following lists.

#### Appliance Package:

Combination Boiler (Assembled.)  
 Installation, Servicing, and Users instructions.  
 Wall mounting templates (Paper)  
 Wall mounting bracket assembly & Fixing screws with wall plugs  
 Safety valve discharge pipe.

Plastic bags containing:  
 Gas Service Cock.  
 CH F/R Isolation valves  
 DHW Isolation valve  
 DHW Compression fitting  
 'O' Ring seal (For elbow)  
 Aluminium ring  
 Associated fixing screws  
 Associated gaskets

**Flue Package:**

Inner duct (flue) c/w flue terminal and centering springs.  
 Outer duct (air)  
 Junction collar  
 Flue elbow  
 Sealing Ring  
 Protective metal sleeve

**Extension duct kit (s) (Optional)**

Inner duct c/w springs  
 Outer duct  
 2 Self tapping screws

**4.2 FIXING THE WALL MOUNTING BRACKET**

*Before installing the appliance ensure that the chosen location is suitable (Section 3.2) and that the requirements for flue position, (Section 3.3), & minimum clearances, (Section 2.1) are satisfied. These minimum clearances are essential to provide access for servicing, and are included on the wall mounting templates.*

- a) Open the paper wall mounting templates. If a rear flue is to be used, discard the side templates and secure the rear template in the desired position. For a side flue application, secure both the rear and appropriate side template in position.
- b) Mark the position of the two wall mounting bracket fixing holes, the two lower frame fixing holes, and the flue / air duct hole on the appropriate wall(s).
- c) Remove the template(s) and drill the top two fixing holes using a 10mm masonry drill and the bottom two fixing holes using a 6mm masonry drill. Fit the plastic plugs provided.
- d) Cut the hole in the wall for the flue / air duct. The diameter should not be less than 100mm (4in) and must be horizontal. If the hole is not accessible from the outside of the building, it's minimum diameter should be sufficient to

allow the insertion of the wall liner (130mm (5 1/4in) diameter) which will be sealed with mortar. Refer to fig 14.  
 (The wall liner (Part No 60342.12) is available as an optional extra.)

- e) Accurately measure the wall thickness, and note this dimension for use later.
- f) Secure the wall mounting bracket in position using the screws provided. Ensure that it is the correct way up, as indicated in fig 8.

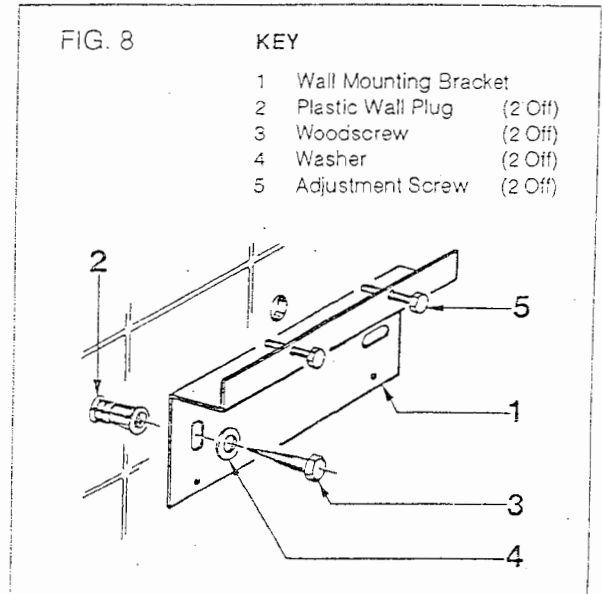

**4.3 HANGING THE APPLIANCE**

- a) Remove the outer casing as follows with reference to fig 9.
  - Remove the front panel fixing screw (6)
  - Remove the front panel (5) by pulling forwards, starting at the top corners.
  - Unscrew the fixing screws (1) securing each side panel (3) and (4) (Two each), and remove the panels by sliding upwards to release the supporting hooks.
- b) Lift the appliance into position. The upper cross member locates onto the wall mounting bracket. Slide the appliance sideways (if necessary) until the lower frame fixing holes line up with the wall plugs.
- c) Screw in the wall mounting bracket adjusting screws until the appliance is secure and vertical, then pivot the control box downwards by removing the two rear screws as shown in fig 15 and fit the two lower fixing screws to

prevent any further movement using a long screwdriver through the clearance holes provided. Pivot the control box back into position and resecure with the two screws

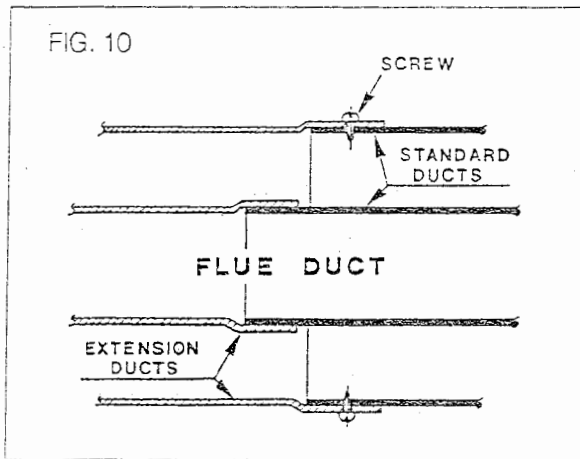
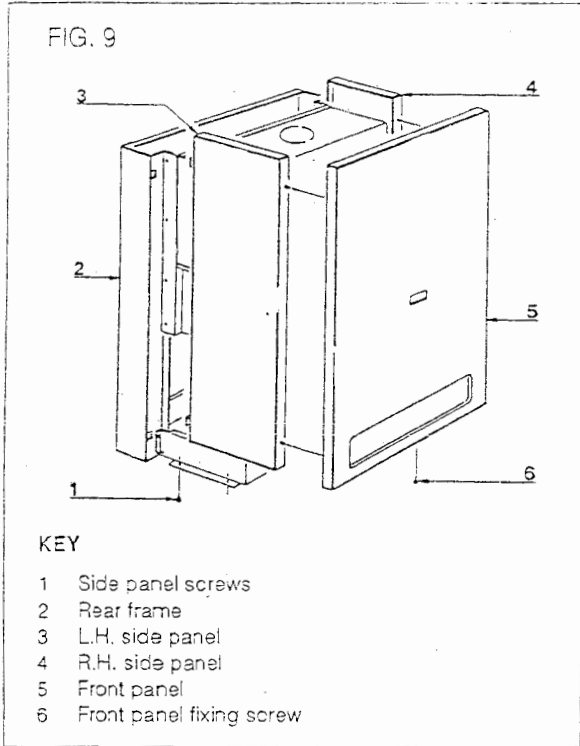

#### 4.4 FLUE AND TERMINAL PREPARATION

If the wall thickness is less than 0.5m (19in) the flue/air duct may be fitted without access to the outside wall providing that the optional wall liner kit is used. (This consists of a steel pipe, 0.5m long and 129mm outside diameter with a 1mm wall thickness.)

#### 4.4.1 Flue/air duct lengths

a) Determine whether an extension duct is required with reference to the "Z" dimension shown in Fig. 11 (Rear Flue), Fig. 12 (Side Flue) and Fig. 14 (Flue Assembly). Alternatively wall thickness information is given in section 2.1.

"Z" Dimension UP TO 945mm  
No Extension duct Required.

"Z" Dimension greater than 945mm and up to 1760mm.  
One Extension duct kit required.

"Z" Dimension greater than 1760mm and up to 2575mm.  
Two Extension duct kits required.

"Z" Dimension greater than 2575mm.  
NOT PERMITTED.

b) If no extension ducts are required, proceed to 4.4.2.

c) If an extension duct or ducts is/are to be used, the flue and air ducts should be joined before proceeding to the next section. The extension ducts should be joined to each other and to the standard ducts using the following procedure (Fig. 10):

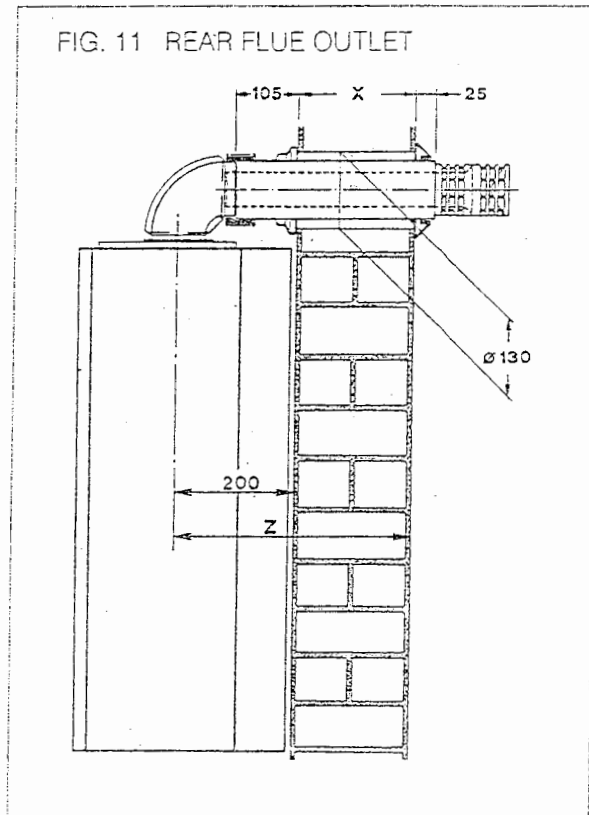

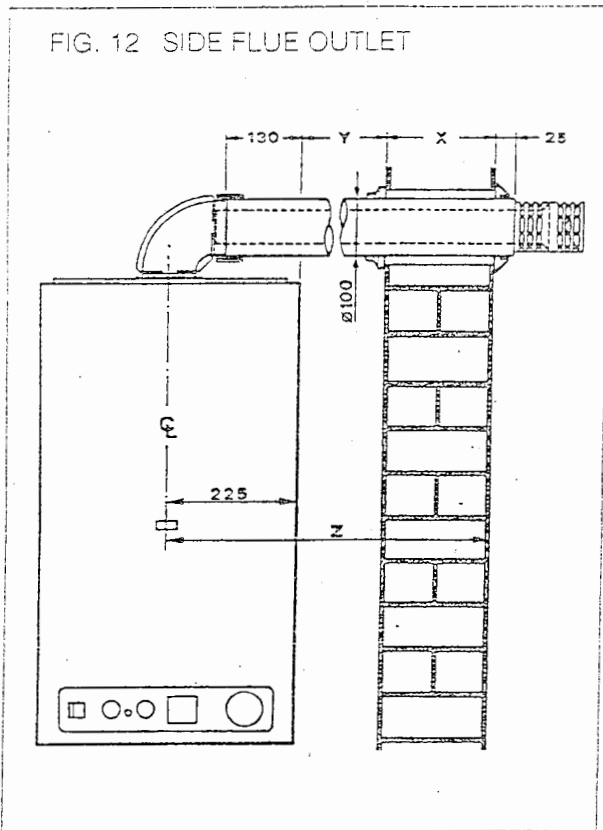

- d) For both the flue and air duct in turn, push the plain end of the standard and (if using two extensions) extension duct into the swaged end of the extension duct(s).
- e) Drill two 3.3mm diameter holes in the air duct (larger duct) as shown in Fig. 10. Screw the two self tapping screws provided with each kit into the holes to secure the joint.

**4.4.2 Cutting the flue/air duct to the correct length**

**(A) Rear flue outlet (Only) (Fig. 11)**

- a) Select the air duct (larger duct) and starting at the formed end, 'mark off' the length to be cut which is the wall thickness 'X' + 130mm (5 3/16 in).

**(B) Side flue outlet (Only) (Fig. 12)**

- a) Select the air duct (larger duct) and starting at the formed end, 'mark off' the length to be cut which is the wall thickness 'X' + the clearance 'Y' plus 155mm (6 3/16 in).

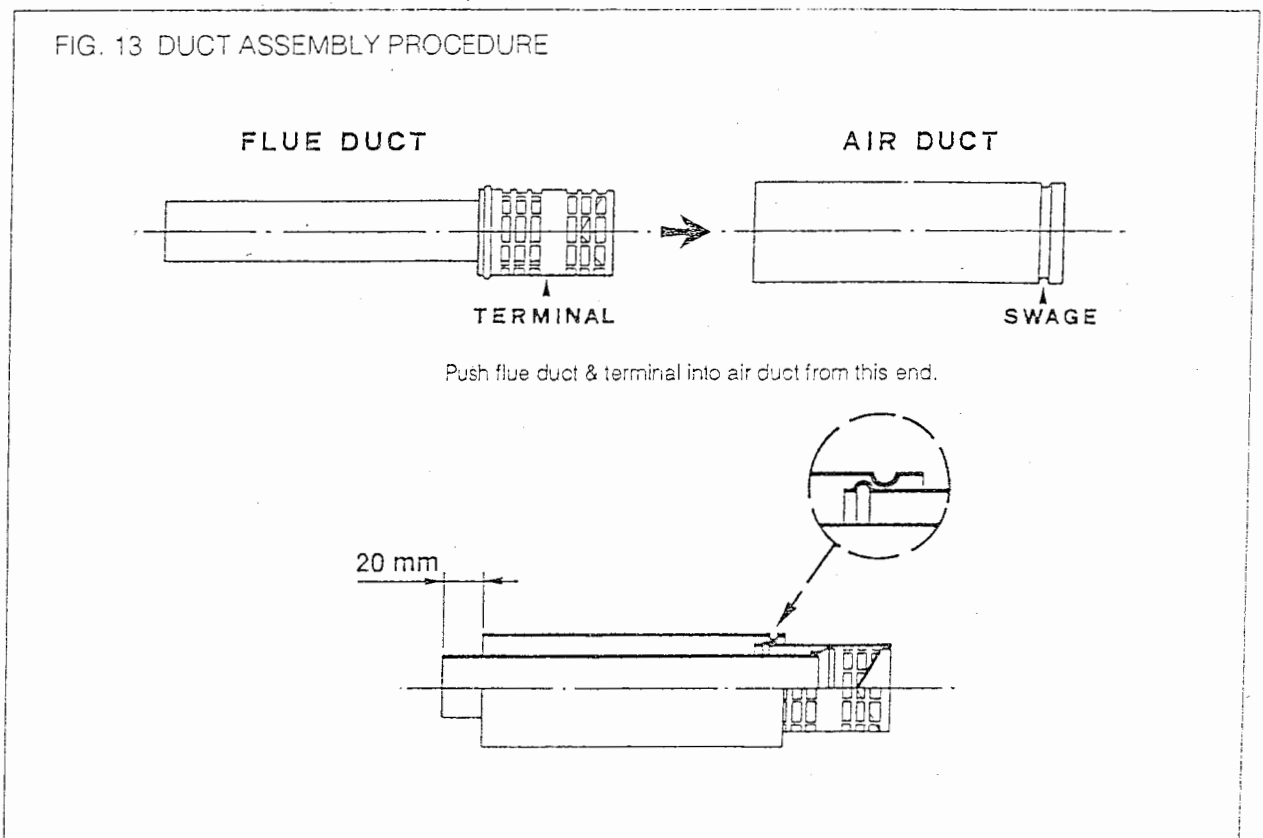
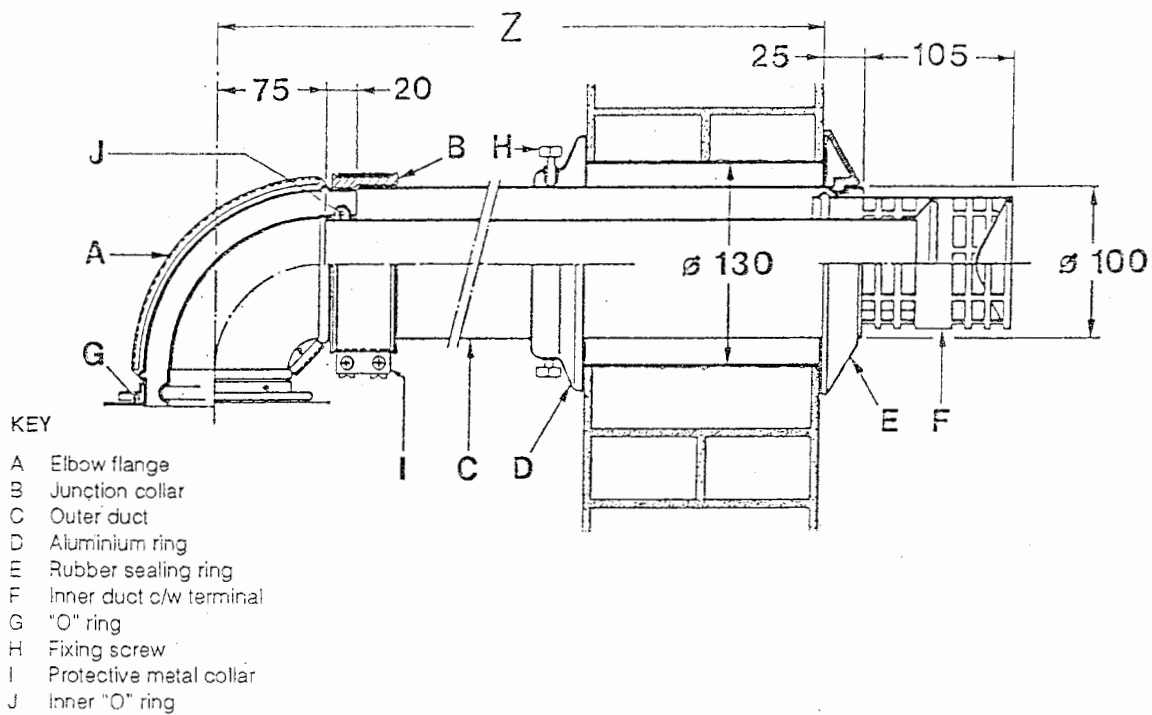

FIG. 14 STANDARD DUCT ASSEMBLY



#### All installations

- b) Cut the air duct square to the mark and remove all burrs and sharp edges.
- c) Refer to Fig. 13. Hold the air duct at the plain end, and slide the flue duct (small duct) inside the air duct (terminal first) until the external swage of the terminal stops against the internal swage of the air duct, then mark off the length to be cut which leaves 20mm protruding flue duct.
- d) Remove and cut the flue duct square to the mark and remove all burrs and sharp edges.

#### 4.5 FLUE AND TERMINAL INSTALLATION

##### 4.5.1 Installations from inside the room

(Wall thicknesses upto 0.5m (19in) only), Hole diameter sufficient to accept wall liner. (130mm (5 1/4in) if optional kit is used). Fig. 14.

- a) A wall liner, 127mm (5 in) internal diameter, 500mm (19 in) long is available as an optional extra for use when fitting the flue/air duct

from inside the building, (or where it is required to seal the hole through a cavity wall). Cut the liner to the wall thickness, insert into the hole, and seal with mortar at inner and outer wall faces. Access to the outside can be made by inserting ones hand through the liner.

- b) Fit the rubber sealing ring into the swaged groove in the air duct as shown in fig. 14. Ensure that it is the correct way around and spray the outside surface with talcum powder or soap solution to reduce friction.
- c) Push the flue duct assembly into the air duct until the external swaged ring on the flue terminal stops against the internal swage on the air duct. (Fig. 13)
- d) From inside the building slide the duct assembly into the wall liner until the sealing ring passes completely through the wall, then pull the air duct back until the ring is pulled up to the wall surface.
- e) Proceed to section 4.5.3.

#### 4.5.2 Installations from outside the building only

(Hole diameter 100mm (4in))

- a) Push the flue duct assembly into the air duct until the external swaged ring on the flue terminal stops against the internal swage on the air duct. (Fig.13)
- b) From inside or outside the building, slide the duct assembly into the wall until the sealing ring forms a good seal against the outside wall.
- c) Fit the rubber sealing ring into the swaged groove in the air duct as shown in fig. 14. Ensure that it is the correct way around.

#### 4.5.3 Connecting the duct assembly - All installation

- a) With reference to fig 14, slide on the aluminium retention ring (D), check that the rubber sealing ring (E) is pulled up to the wall and that the duct assembly is horizontal, then secure the aluminium retention ring to the air duct using the two screws (H) provided. Do not overtighten the screws.
- b) Push the junction collar (B) over the air duct until the air duct touches the inner part of the collar where the diameter becomes smaller (Fig. 14).
- c) Push the elbow socket into the junction collar and onto the flue duct.
- d) Fit the protective metal collar (I Fig. 14) over the junction collar.
- e) Release the two spring clips and remove the four fixing screws securing the sealed chamber front panel (Fig. 2) then remove the panel.
- f) Place the "O" ring (G, Fig. 14) under the flange of the elbow and fit the elbow onto the top of the appliance, taking care to ensure that the silicon seal on the fan outlet correctly engages and forms a seal at its joint with the elbow. This must be checked from inside the sealed chamber.
- g) Secure the elbow onto the top of the appliance using the four screws and washers provided, and refit the sealed chamber front panel.

## 4.6 WATER CONNECTIONS

### 4.6.1 Central heating connections

- a) Fit the two CH isolation valves using the gaskets supplied to the connections as shown in Fig. 3. The pipe connections are labelled underneath the boiler.
- b) Connect the central heating pipework as required.

### 4.6.2 D.H.W connections

- a) Fit the DHW isolation valve on the cold water inlet connection as shown in Fig. 3.
- b) Fit the union connection to the DHW outlet.
- c) Connect the DHW pipework as required.
- d) If a DHW expansion vessel is to be fitted, remove the screwed plug from the DHW expansion vessel connection on the left of the appliance (Fig. 3), and screw the vessel into position using a jointing compound suitable for potable water.

## 4.7 GAS CONNECTIONS

- a) Screw the gas cock into the **internal thread** in the gas inlet connection using a suitable jointing compound.
- b) Connect the gas supply pipe.

## 4.8 SAFETY VALVE CONNECTION

- a) The appliance safety valve is located towards the RHS of the boiler and the discharge pipe is supplied loose. Remove the two screws (2) fig 15 and lower the control box to improve access.
- b) Screw the discharge pipe to the valve outlet using a suitable jointing compound, and extend the pipe to ensure that any discharge from the safety valve is safely routed to a drain. The discharge pipe should be a minimum of 15mm copper, and should avoid sharp corners or upward pipe runs where water may be retained.



#### 4.9 WIRING INSTRUCTIONS (REFER TO SECTION 3.6/3.7)

The external wiring is connected to the boiler via a plug situated behind the control box at the LHS.

- a) Access the plug by removing the two screws ((2), Fig. 15) and lowering the box until it rests against its stops.
- b) Disconnect the plug by sliding backwards, and lifting clear.
- c) Pass the supply cable through one of the strain relief bushes in the connection plate at the bottom of the boiler on the LHS and connect to the terminals marked L,N, and - inside the plastic plug (Fig. 16). ENSURE that the earth conductor length is such that if pulled from its anchorage the current carrying conductors become taut before the earth conductor. All cables must be secured in the anchorage.

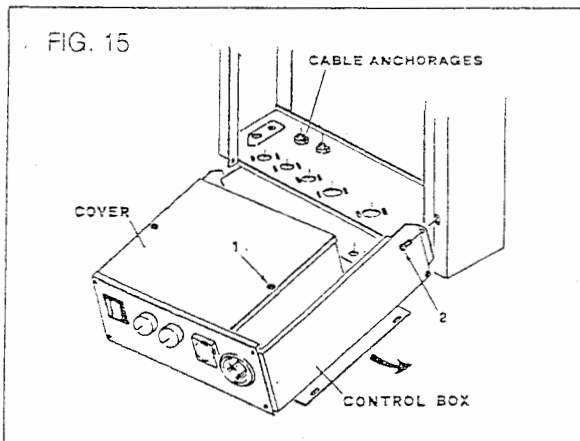

- d) If a room thermostat is to be used, remove the link between terminals 40 and 41 in the connector plug and replace it with the room thermostat.
- e) Connect the mains plug as illustrated in Fig. 17.
- f) Carry out electrical systems checks with a suitable test meter: Earth continuity, polarity, resistance to earth, and short circuit.
- g) Resecure control box.

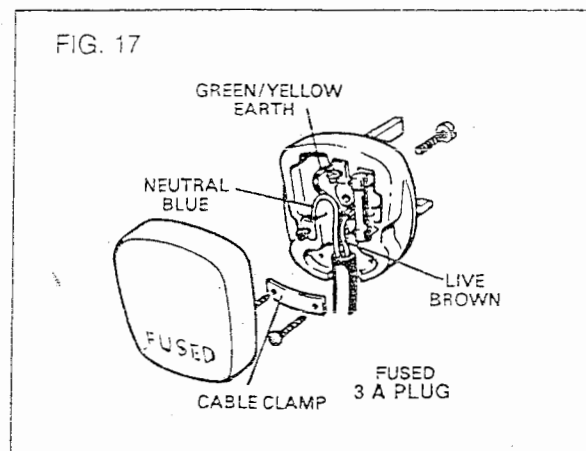
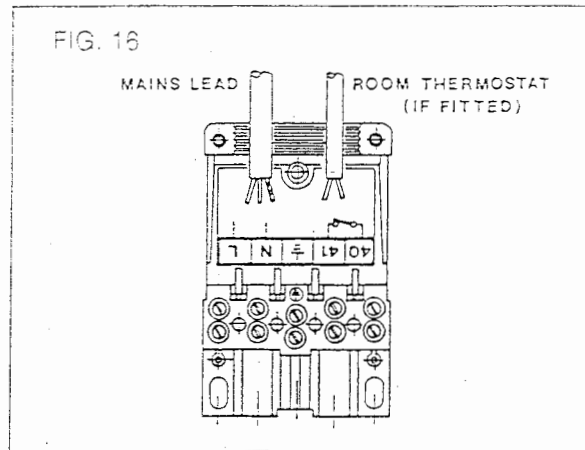

## 5 COMMISSIONING AND TESTING

Before commissioning the appliance, the whole gas installation including the meter MUST be purged and tested for gas soundness in accordance with BS 6891:1988.

**IMPORTANT:** Open all doors and windows, extinguish naked lights, and DO NOT SMOKE whilst purging the gas line.

Before commencing the commissioning procedure, ensure that the gas service cock is turned on, the electricity supply is isolated, and that the DHW and CH isolation valves are in the closed position.

### 5.1 FILLING THE WATER SYSTEM

- a) Open the CH flow and CH return valves. Items 18 Fig. 3.
- b) Loosen the automatic air vent cap on the flow pipe near the heat exchanger, and the manual vent above the pump. Items 14 & 19 Fig. 3.

- c) Open all radiator valves and system air vents. Fill the system with water using one of the approved methods described in section 3.9 to about 0.5 bar greater than the system design pressure. Close all air vents. Do not forget the one near the pump!
- d) Check the system for water soundness.
- e) Completely drain the appliance and heating system, thoroughly flush the system, and refill as in (c) to the system design pressure.
- f) Open the DHW Inlet valve (Item B Fig. 3), open any hot tap, clear of air bubbles. Close hot tap.

### 5.2 COMMISSIONING THE BOILER

- a) Remove the screw and connect a pressure gauge to the burner pressure test point on the gas valve. (Fig. 18).

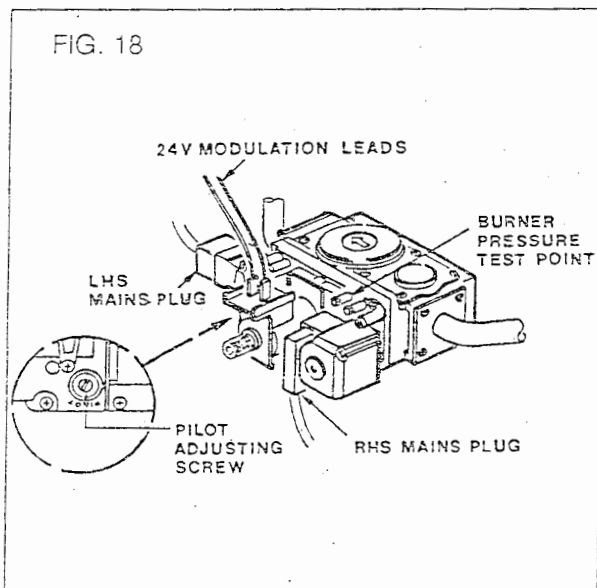

- b) Ensure that the summer / winter switch on the fascia panel (Fig. 24) is set to the summer position ☀ (DHW Only), turn the DHW thermostat (3 Fig. 19) to maximum (fully clockwise), and turn on the electrical supply. Fully open any DHW tap and the burner will light.
- c) Allow the boiler to run for at least 2 minutes and check that the burner pressure is as stated in Section 2.1. The DHW burner pressure is factory set and should not require adjusting. If the burner pressure is low, check that the appliance has not begun to modulate (This will

occur if the DHW flow rate is low. If modulation is suspected, open all DHW taps to maximise flow and recheck burner pressure.) If it is necessary to adjust the DHW burner pressure the method is described in section 9.6 - Gas valve replacement, steps 8 b) i to vii

- d) Reduce the DHW draw off rate to the minimum necessary to maintain the burner alight by carefully adjusting the DHW Inlet valve and check that the burner pressure decreases in response to DHW temperature rise. Fully open the inlet valve.
- e) Close the DHW tap and ensure that the burner is extinguished and the pump stops.

### 5.3 SETTING THE C.H. INPUT

- a) Turn the Summer/Winter switch to the Winter position ❄ and turn the time clock override switch (Next to the Summer/Winter switch in the fascia panel) to the override position ☒. Ensure that the room thermostat (If fitted) is calling for heat. Turn the CH thermostat knob (1, Fig. 19) to maximum (fully clockwise) and the burner will light.
- b) Allow the boiler to run for at least 2 minutes and check the burner pressure. The heating input is factory set at 29.3kW (100,000Btu/h) which is required to give 23.4kW (80,000Btu/h) output and this is the maximum permitted.
- c) If the heating output is to be adjusted, proceed as follows:
  - Refer to section 2.1 and establish the desired burner pressure.

FIG. 19

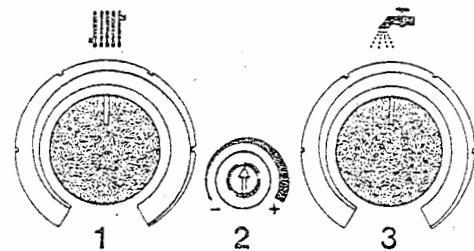

FACIA PANEL THERMOSTATS AND POTENTIOMETER (2)

- Remove the black plastic cover protecting potentiometer 2. (Fig. 19).

- Set the burner pressure as required using a small screwdriver on potentiometer 2. Rotate the screw anti-clockwise to reduce the burner pressure.

- Operate the Summer/Winter switch a few times and check that the correct burner pressure is maintained.

d) Replace the black plastic cover over potentiometer 2.

e) Check that the pilot flame is the correct length (12mm (1/2 in)) and touches the electrode. To do this isolate the electrical supply, remove the LH mains plug from the gas valve (Fig. 18) and restore the mains supply. The pilot will light, but not the main burner. Check the pilot flame and adjust if necessary. See Fig. 18 for the pilot adjusting screw. (Anticlockwise rotation increases pilot length), then isolate the electrical supply, refit the LH mains plug and restore the electricity supply again.

f) Turn the time clock override switch to 'Clock' position and check the operation of the time clock and room thermostat (if fitted).

#### g) SETTING THE TIME CLOCK.

To set the time clock proceed as follows:

- Remove the plastic cover from the front of the clock by rotating clockwise 1/8 of a turn and pulling forwards.

- 6 tabs are supplied, 3 green to turn the heating on, and 3 red to turn the heating off. Push them into the clock dial at the times corresponding to when the heating is desired on and off. Spaces are available near the centre of the clock to store spare tabs if three time periods are not required.

- Set the clock to the correct time by rotating the dial clockwise until the arrow at the top RHS corresponds to the current time.

### 5.4 SETTING THE DHW FLOWRATE

A restrictor screw (Fig. 20) is fitted to reduce the DHW flow to that which will give an acceptable DHW temperature. To set the DHW flow, proceed as follows.

a) Select Summer position  and turn the DHW thermostat to max. ('3', Fig. 19).

FIG. 20 DIVERTOR VALVE



b) Fully open the DHW tap furthest from the boiler.

c) Check that the boiler is firing at maximum burner pressure.

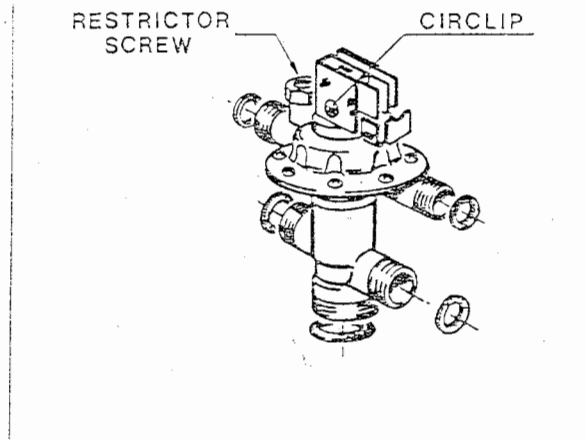
d) Adjust the DHW flowrate by turning the restrictor screw on the divertor valve until a DHW temperature rise of approx 35°C is achieved. This corresponds to a flowrate of approximately 10.8 l/min (2.4 gpm).

e) Turn off the tap.

f) Remove the pressure gauge and refit the sealing screw.

g) Relight and test for gas soundness.

### 5.5 FINAL CHECKS

a) Re-fit the casing in reverse order.

b) Set the CH and DHW thermostats to the required settings.

c) Ensure that the clock override switch is in the clock position, and check that the time clock is set at the desired time periods. Set the room thermostat (if fitted) to the required setting.

### 5.6 USER'S INSTRUCTIONS

Upon completion of commissioning and testing the system, the installer should hand over to the user, with reference to the following.

- a) Give the 'Users Instructions' to the householder and emphasise their responsibilities under the 'Gas Safety (Installation and Use) Regulations 1984.'
- b) Explain and demonstrate the lighting and shutdown procedures.
- c) Advise the householder on the efficient use of the system, including the use and adjustment of all system controls for both DHW and CH.
- d) Advise the user of the precautions necessary to prevent damage to the system, and to the building, in the event of the system remaining inoperative during frost conditions.
- e) Explain the function of the boiler over-heat thermostat, and how to reset it. Emphasise that if cut-out persists, the boiler should be turned off and the installer or service engineer consulted.
- f) Stress the importance of an annual service by a competent heating engineer.

## 6 ROUTINE SERVICING INSTRUCTIONS

To ensure continued efficient operation of the appliance, it is recommended that it is checked and serviced as necessary at regular intervals. The frequency of servicing will depend upon the particular installation conditions and usage but in general once a year should be adequate. It is the law that any service work must be carried out by a competent person such as British Gas or other CORGI registered personnel. Before commencing any service operation, ISOLATE the mains electrical supply, and TURN OFF the gas supply at the main service cock. Service the appliance by following the full procedure detailed below :

### a) Main burner assembly

- 1 Remove the front casing panel by unscrewing the retaining screw situated underneath the front panel, and pulling the panel forwards from the top corners whilst holding the side panels in place.
- 2 Remove both casing side panels by unscrewing the two screws in each situated underneath the side panel, and lifting the panels vertically upwards to release them. (Fig. 9).

- 3 Release the two spring clips and remove the four fixing screws securing the sealed chamber front panel (Fig. 21) then remove the panel.
- 4 Unscrew the 5 screws securing the combustion chamber front panel and remove the panel, taking care not to damage the insulation. (Fig. 21).
- 5 Unscrew the spark electrode and withdraw.
- 6 Unscrew the pilot pipe from the pilot burner and withdraw the pipe. Carefully remove the pilot injector. It may be necessary to remove the pilot bracket to do this.
- 7 Unscrew the burner manifold union. (Fig. 21)
- 8 Remove the burner assembly locking nut. (Fig. 21)
- 9 Lift the front of the burner sufficiently to disengage the manifold thread. Carefully slide the burner forwards and withdraw the burner.
- 10 Remove the burner manifold by disconnecting the four posi-head screws. (Fig. 24)
- 11 Inspect and if necessary, clean the injectors.
- 12 Inspect and if necessary, clean the main burner bars.

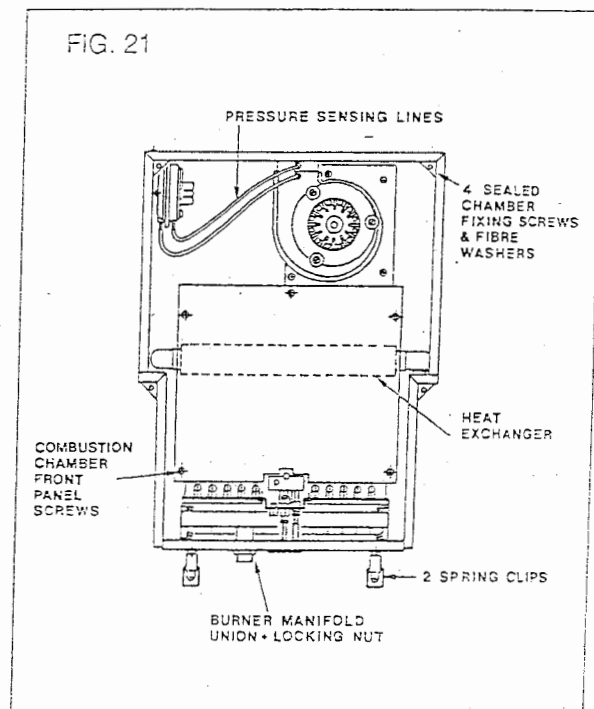

### b) Pilot assembly

- 13 Inspect the pilot injector. Clean if necessary.
- 14 Inspect and clean (if necessary) the pilot burner. Ensure that it is free from debris.
- 15 Re-assemble the burner assembly in reverse order ensuring that the baffle is correctly re-positioned. Do not reassemble any other components until the service is completed.

### c) Fan assembly

- 16 Disconnect the electrical connections to the fan. Note the position of the earth conductor.
- 17 Pull off the two pressure sensing lines.

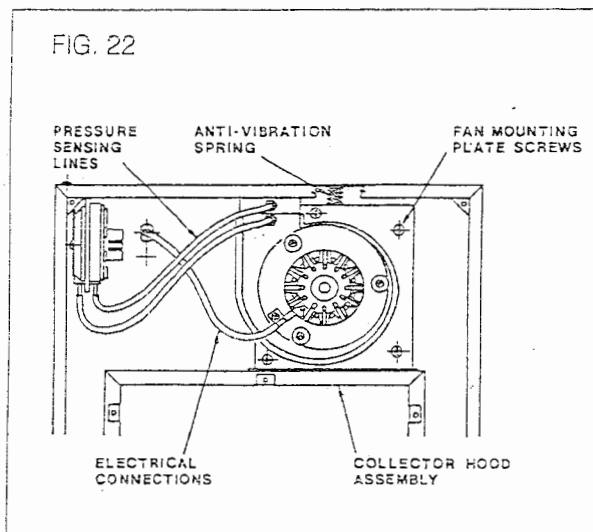

- 18 Remove the four screws securing the fan mounting plate.
- 19 Tilt the fan assembly forwards and remove in a downwards direction.
- 20 Inspect the fan assembly and clean if necessary.

### d) Heat exchanger

- 21 Remove the anti-vibration spring on the top of the collector hood (Fig. 22)
- 22 Lift the collector hood assembly, tilt forwards and remove the hood.
- 23 Inspect the heat exchanger, and clean if necessary.

### e) Re - Assembly

- 24 Reassemble all components in reverse order. Check for gas soundness before fitting the outer case. Ensure that all seals are correctly fitted and that the pressure sensing lines are correctly fitted as shown in Fig. 23. (Red dot to Red dot.) Ensure that the earth connection is correctly refitted. Note that the polarity (Live & Neutral) is immaterial.

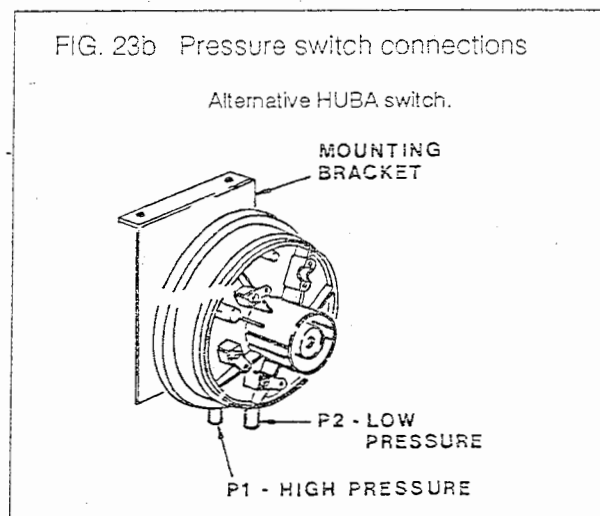
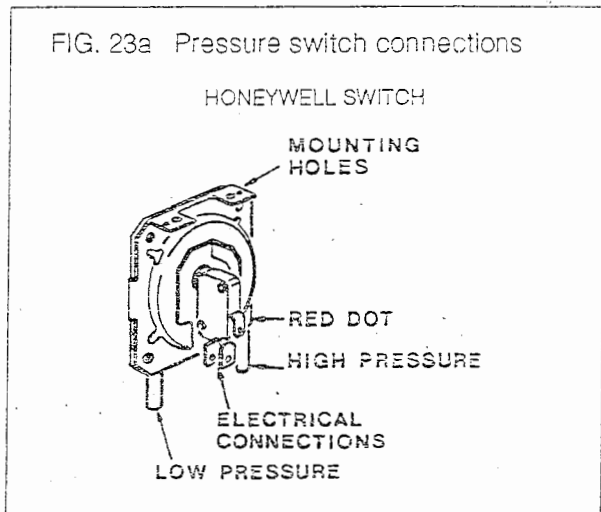

### e) Re-Commissioning

- a) Turn on the gas supply, and check for gas soundness whilst the appliance is running.
- b) Check the operation of the appliance in both CH and DHW mode and ensure in both cases that the burner pressure after at least 2 minutes running is as stated on the data plate or in section 2.1. Adjust if necessary as described in section 5.

## 7 FAULT FINDING

### Important Notice

If an electrical fault occurs on the appliance the preliminary electrical system checks contained in the British Gas Multimeter Instruction Booklet must be carried out first.

When any service or replacement of electrical components which has required the breaking and re-making of electrical connections has taken place, the following tests must be repeated:

- 1 Earth Continuity
- 2 Short circuit
- 3 Polarity
- 4 Resistance to Earth

### 7.1 EARTH CONTINUITY CHECK

Appliances must be electrically disconnected, meter set on  $\Omega$  (ohms)  $\times 1$  scale and adjust zero if necessary.

Test leads from any appliance earth point (e.g. inside control box) see wiring diagrams (Sect. 8) to earth pin on plug. Resistance should be less than  $1\Omega$  (ohm). If the resistance is greater than  $1\Omega$  (ohm) check all earth wires for continuity and all contacts are clean and tight.

If the resistance to earth is still greater than  $1\Omega$  (ohm) then this should be reported to your supervisor.

### 7.2 SHORT CIRCUIT CHECK

Switches turned FULL ON – meter set on  $\Omega$  (ohm)  $\times 1$  scale. Test leads from L to N on appliance terminal block, if meter reads 0 then there is a short circuit. Meter set on  $\Omega$  (ohms)  $\times 100$  scale.

Repeat it with leads from L to E. If meter reads less than infinity ( $\infty$ ) there is a fault.

**NOTE:** Should it be found that the fuse has failed but no fault is indicated, a detailed continuity check (i.e. by disconnecting and checking each component) is required to trace the faulty component.

It is possible that a fault could occur as a result of local burning/arcing but no fault could be found under test. However, a detailed visual inspection should reveal evidence of burning around the fault.

### 7.3 POLARITY CHECK

Appliance reconnected to mains supply and meter set on 300V ac scale. Test at appliance terminal block.

(a) Test leads from L to N meter reads approx: 240V ac.

(b) Test leads from L to E (  ) meter reads approx. 240V ac.

(c) Test leads from N to E (  ) meter reads from 0 to 15V ac.

### 7.4 RESISTANCE TO EARTH CHECK

Appliance must be disconnected from main supply and meter on  $\Omega$  (ohms)  $\times 100$  scale. All switches including thermostaton-test leads from L to E - if meter reads other than infinity ( $\infty$ ) there is a fault which should be isolated. A detailed continuity check is required to trace the faulty component.

**IMPORTANT:** These series of checks are the first electrical checks to be carried out during a fault finding procedure. On completion of the service/fault finding task which has required the breaking and remaking of electrical connections then the checks 7.1. Earth Continuity, 7.3 Polarity and 7.4 Resistance to Earth must be repeated.

## 7.5 CH MODE - FAULT FINDING

- Start from Cold
- Summer/Winter switch set to Winter (☒) position.
  - Room thermostat (if fitted) calling for heat. & all DHW taps off.
  - CH thermostat set to maximum position.
  - Clock override switch in the on position (☒).

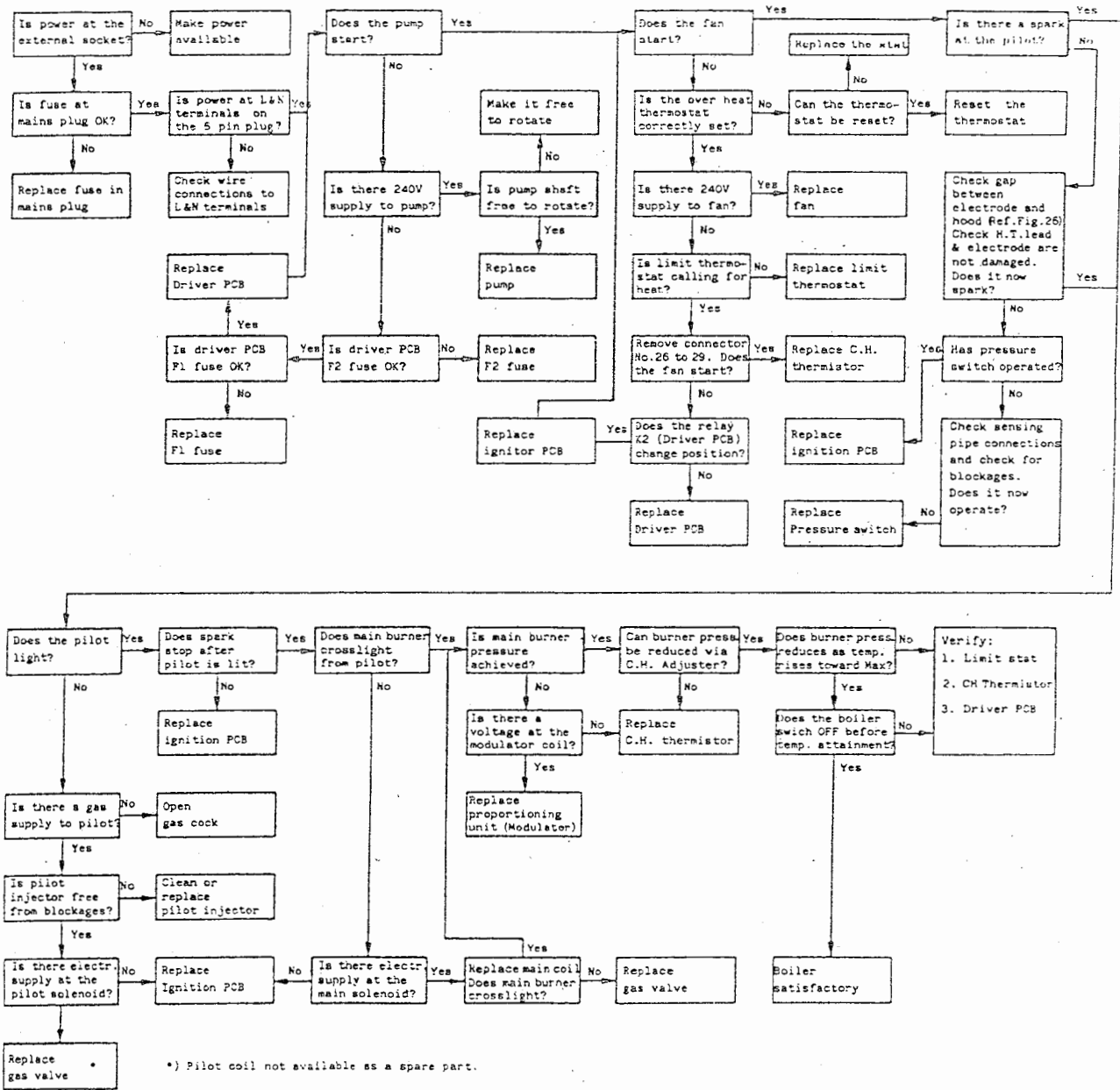

NOTE: After completing fault finding, Reset the room thermostat (if fitted) to the required setting and turn the clock override switch to the clock position (☒) if the appliance will not function on 'clock' setting. Check the wiring to the clock and if necessary, replace the clock.

## 7.6 DHW MODE - FAULT FINDING

Start from Cold - Summer/Winter switch set to Summer position, DHW thermostat set to maximum, and all D.H.W. taps OFF.

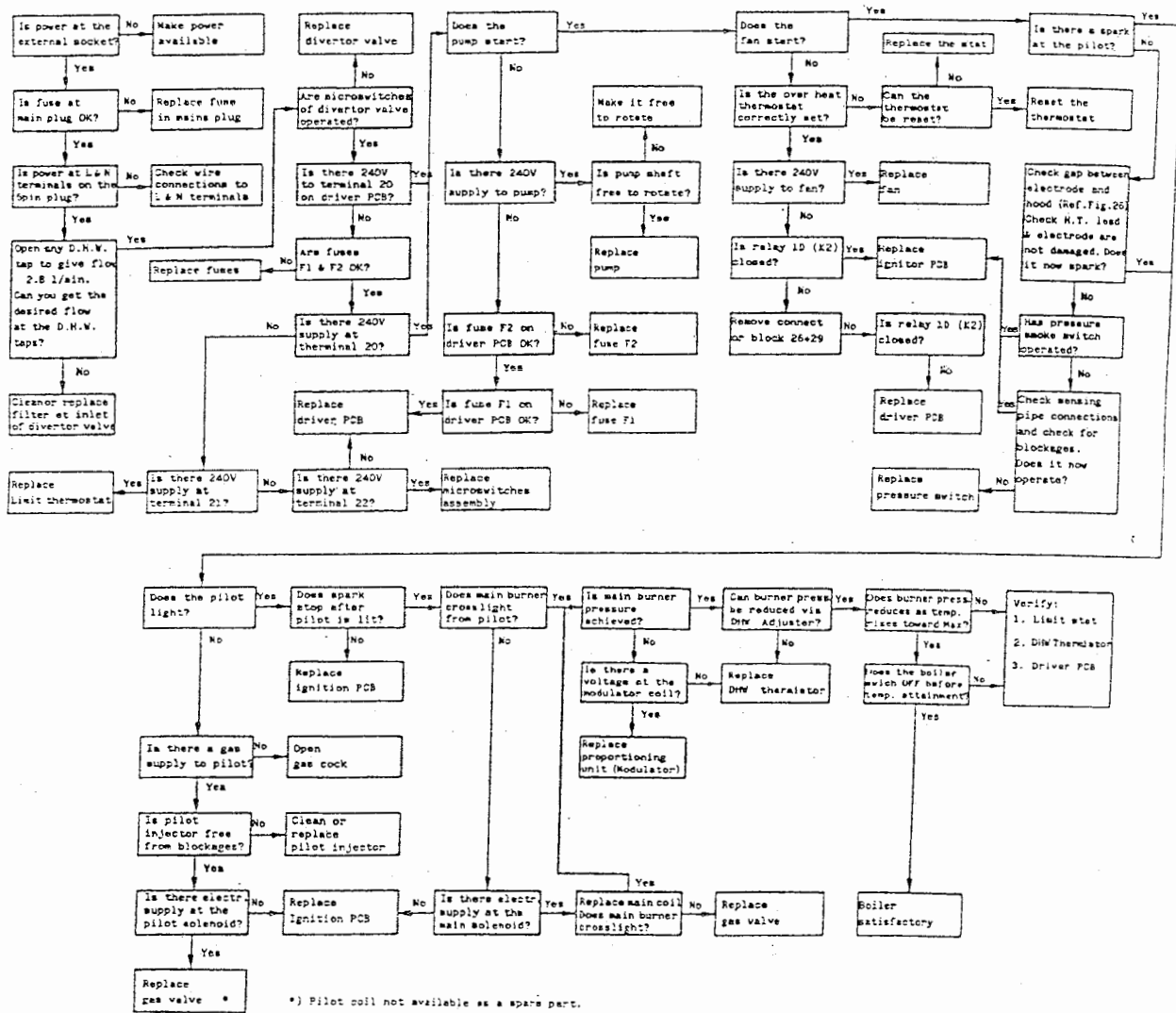



# 8 INTERNAL WIRING DIAGRAMS

## 8.1 FUNCTIONAL FLOW WIRING DIAGRAM

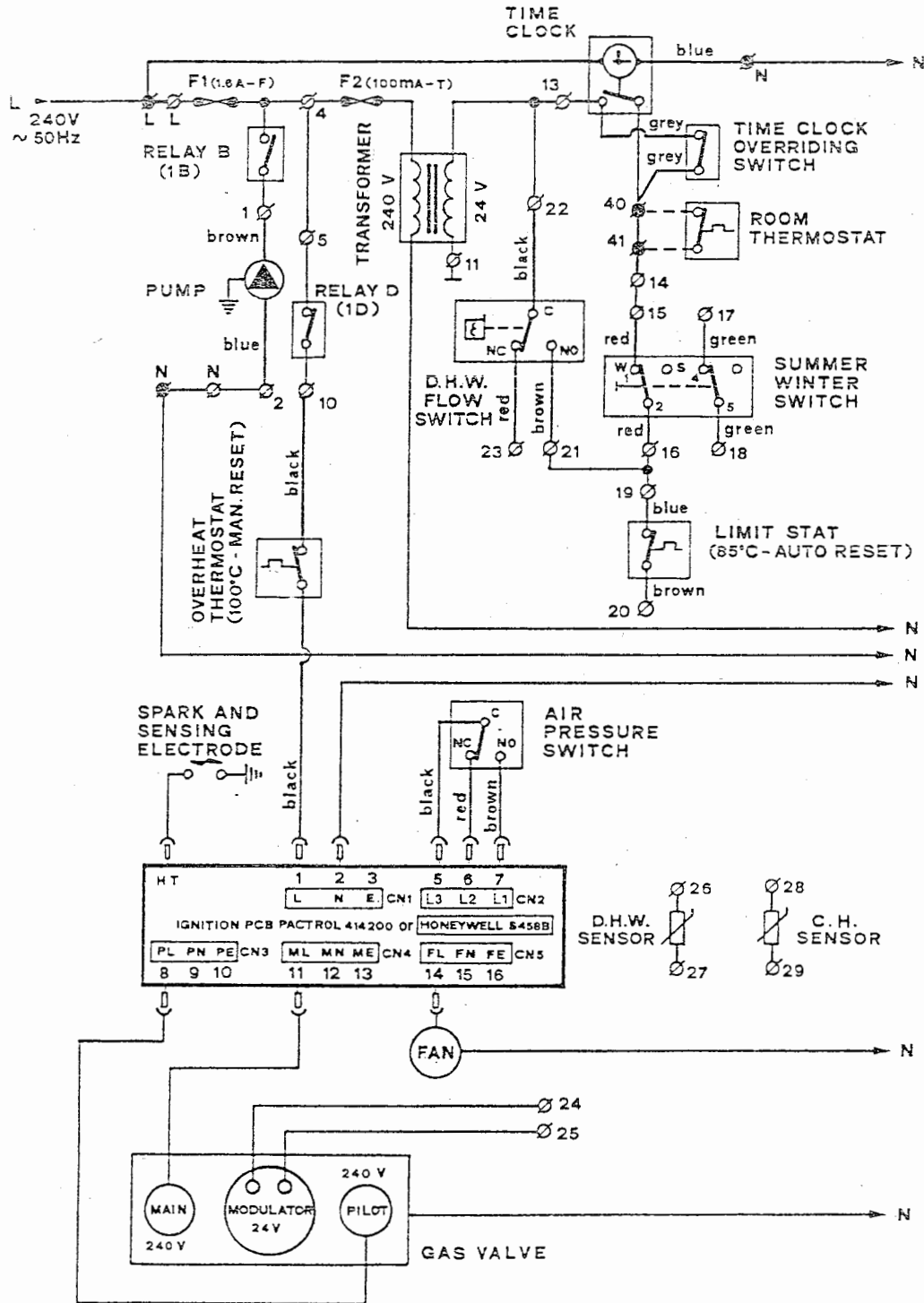

WHEN A ROOM STAT IS FITTED REMOVE LINK 40 - 41

Ø TERMINALS ONTO THE SIME PCB

⊗ TERMINALS ONTO THE 5 PIN PLUG

8.2 ILLUSTRATED WIRING DIAGRAM

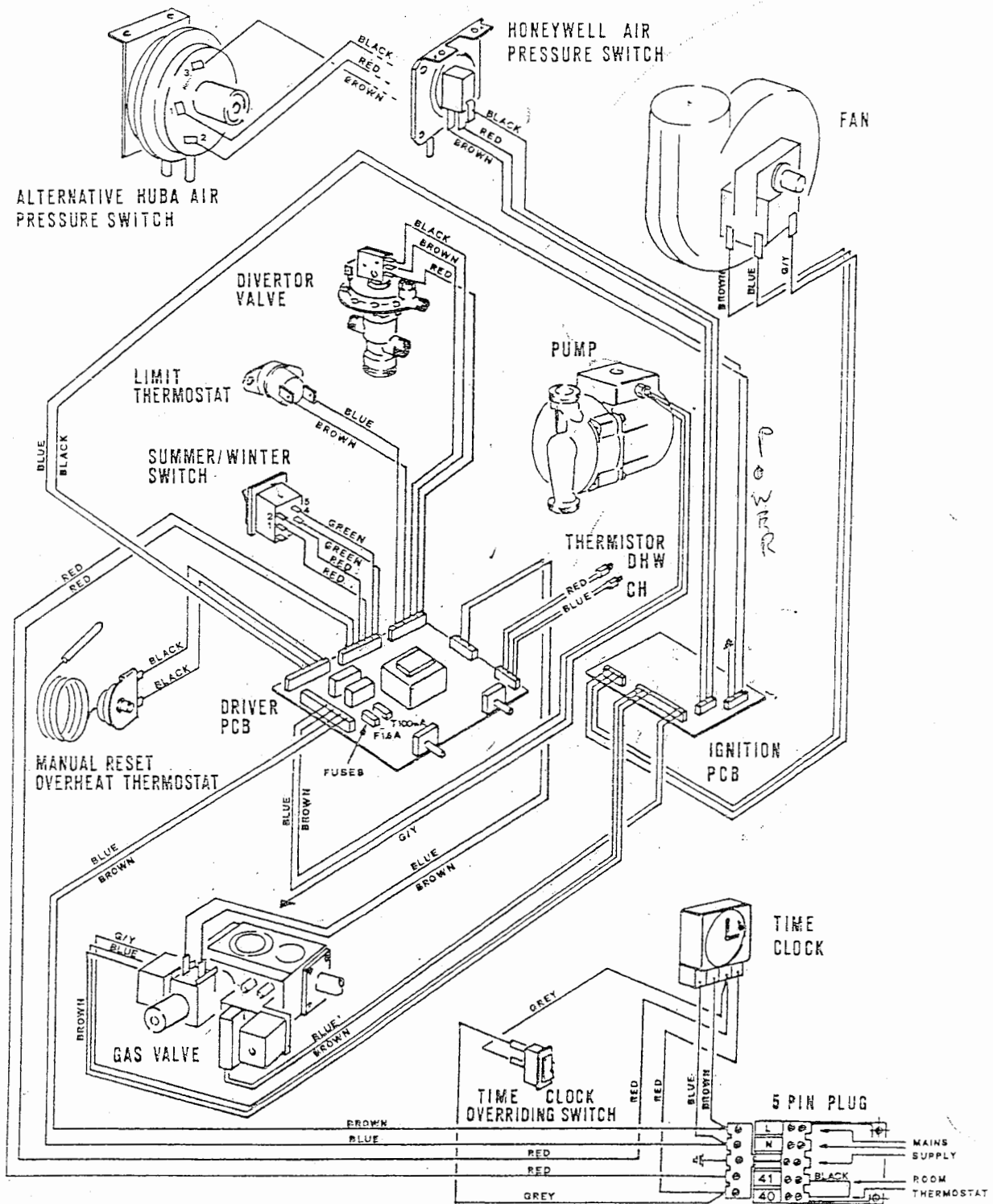
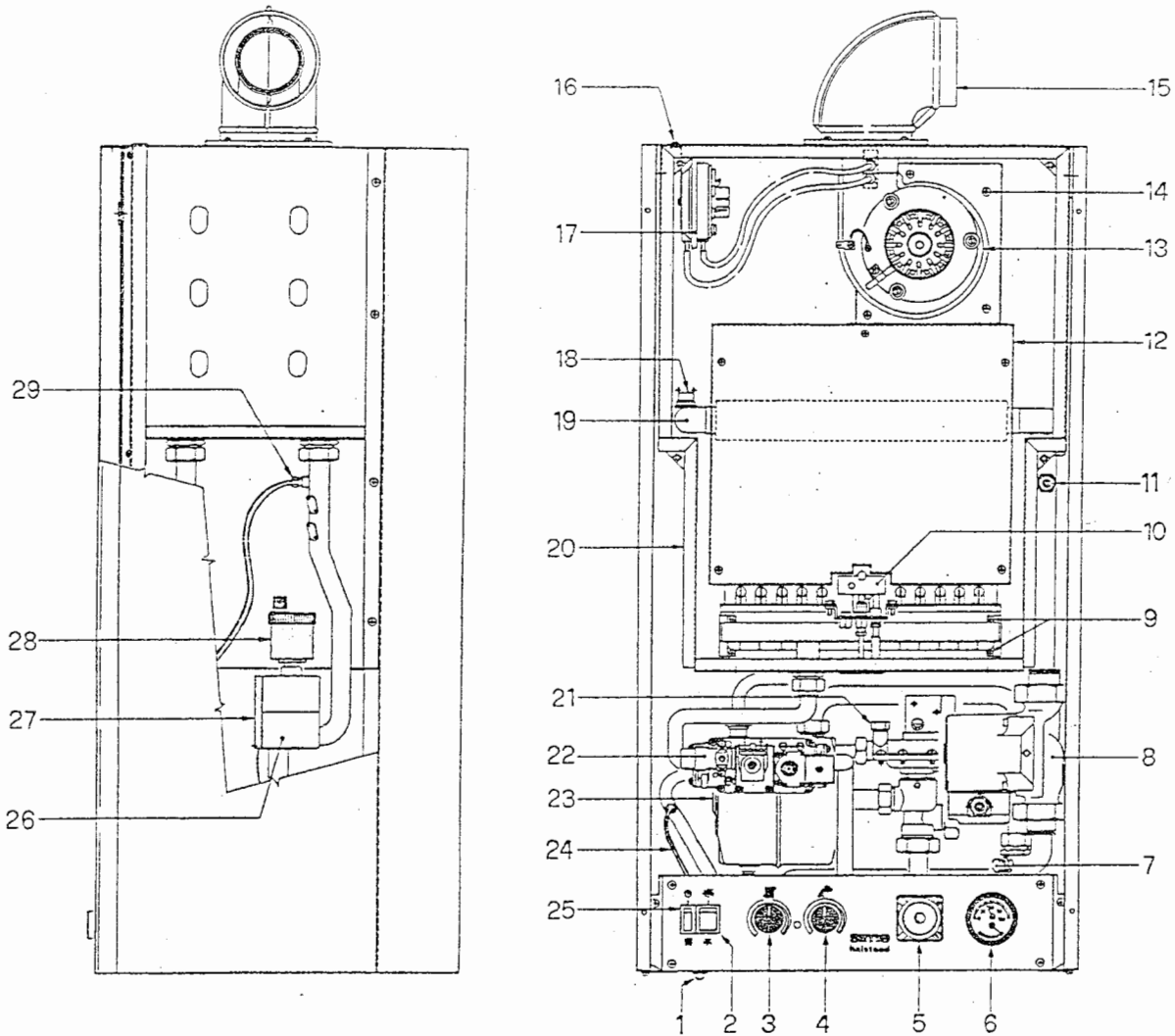

FIG. 24 INTERNAL VIEWS



RHS VIEW

FRONT VIEW

KEY

- |                              |                                   |
|------------------------------|-----------------------------------|
| 1 Overheat thermostat        | 16 Pressure switch bracket screws |
| 2 Summer/Winter switch       | 17 Pressure switch                |
| 3 C.H. potentiometer         | 18 Limit thermostat               |
| 4 D.H.W. potentiometer       | 19 Heat exchanger                 |
| 5 Time clock                 | 20 Sealed chamber                 |
| 6 Pressure/Temperature gauge | 21 D.H.W. restrictor              |
| 7 Drain cock                 | 22 Gas Valve                      |
| 8 Circulating pump           | 23 D.H.W. heat exchanger          |
| 9 Burner manifold screws     | 24 D.H.W. termistor               |
| 10 Pilot assembly            | 25 Time clock overriding switch   |
| 11 Manual air vent           | 26 Air separator                  |
| 12 Collector hood            | 27 Overheat thermostat phial      |
| 13 Fan                       | 28 Automatic air vent             |
| 14 Fan mounting plate screws | 29 C.H. thermistor                |

## 9 REPLACEMENT OF PARTS

Before commencing any service operation, ISOLATE the mains electrical supply, and TURN OFF the gas supply at the main service cock. It is the law that any service work must be carried out by a competent person such as British gas or other Corgi registered personnel.

### 9.1 HEAT EXCHANGER

- 1 Remove the fan as described in section 9.3 steps 1 to 5.
- 2 Remove the anti-vibration spring on the top of the collector hood. (Fig. 22).
- 3 Lift the collector hood assembly, tilt forwards, and remove the hood.
- 4 Isolate the CH flow and return valves.
- 5 Drain the heat exchanger using the drain cock (Fig. 3).
- 6 Unscrew the two heat exchanger unions and the locking nuts, then lift out the heat exchanger.
- 7 Re-assemble in reverse order, ensuring that the pressure sensing pipes and anti vibration spring are correctly re-fitted (Figs 22 & 23). The fan polarity is not important except the earth conductor (G/Y which is marked on the appliance.) Refill, and re-commission the system as described in section 5 Commissioning and testing.

### 9.2 HEAT EXCHANGER INSULATION

The design of this appliance is such that the rear and side insulation should not require replacement unless mechanically damaged. To replace the insulation front panel, proceed as follows:

- 1 Remove the combustion chamber front panel as described in section 6a steps 1 to 4.
- 2 Replace the front insulation panel and glue it into position on the front panel using the glue supplied. Re-assemble in reverse order.

Should the rear or side panels become damaged, replace them as follows.

- 1 Remove the heat exchanger as described in section 9.1, steps 1 to 7
- 2 Remove the side insulation panels followed by the rear panel.
- 3 Re-assemble in reverse order, refill, and recommission the system as described in section 5.

### 9.3 FAN ASSEMBLY

- 1 Remove the outer casing and the sealed chamber front panel as described in section 6a, steps 1,2, and 3.
- 2 Disconnect the electrical connections to the fan. Note the position of the earth conductor.
- 3 Pull off the two pressure sensing lines. (Refer to Fig. 22)
- 4 Unscrew the four screws securing the fan mounting plate. (Fig. 24)

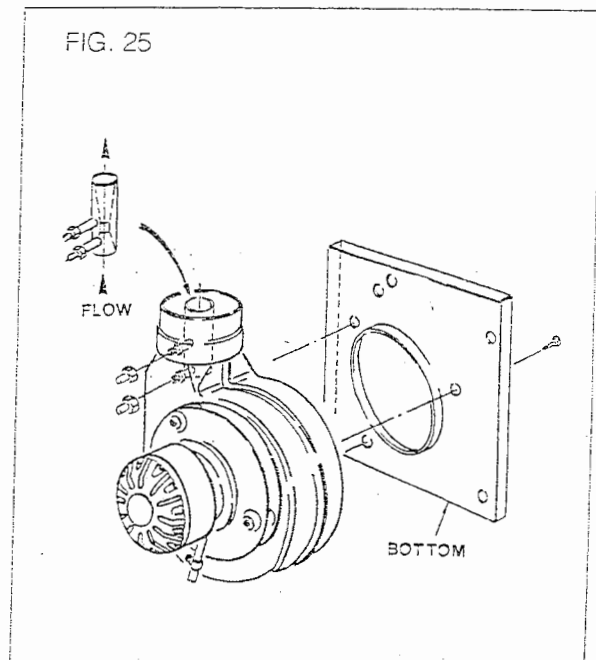

- 5 Drop and tilt the fan assembly forwards and remove in a downwards direction.
- 6 Unscrew the three screws retaining the fan on the fan plate. Fig. 25. Remove the fan assembly.
- 7 Transfer the pressure sensing venturi from the old fan to the new one, ensuring that it is fitted in the correct direction as shown in Fig. 25.

- 8 Transfer the fan outlet seal onto the new fan.
- 9 Reassemble in reverse order. Ensure that the earth connection is correctly refitted. Note that the polarity (Live and Neutral) is immaterial. Ensure that the pressure sensing leads are correctly connected - red dot to red dot and plain to plain.

#### 9.4 MAIN BURNER

- 1 Remove the main burner by following section 6a, steps 1 to 9.
- 2 Transfer the pilot assembly onto the new burner assembly.
- 3 Re-assemble in reverse order and check for gas soundness.

#### 9.5 PILOT BURNER ASSEMBLY AND ELECTRODE

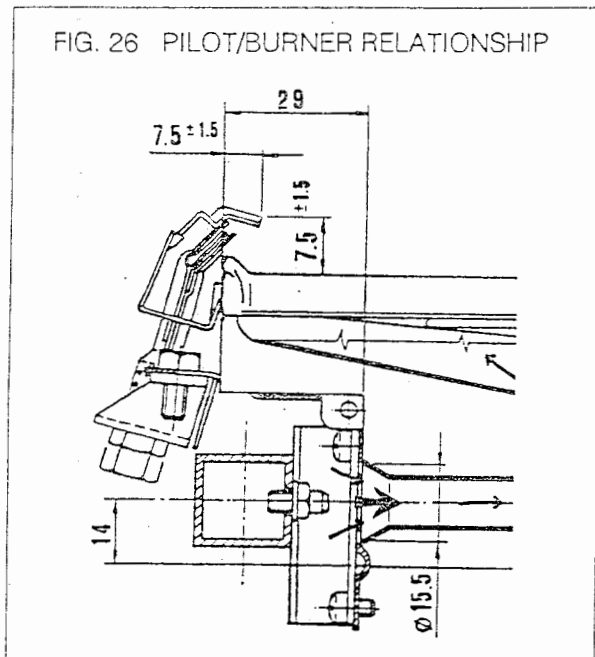

- 1 Remove the combustion chamber front panel as described in section 6a steps 1 to 4.
- 2 Unscrew electrode. TO REPLACE ELECTRODE ONLY - Replace electrode, and go to step 4.
- 3 Remove the old pilot burner and replace with the new one. Check that the critical dimensions are as shown in fig 26.
- 4 Re-assemble in reverse order and check for gas soundness.

#### 9.6 GAS VALVE

- 1 Remove the outer casing as described in section 6a, steps 1 and 2.
- 2 Disconnect the electrical connections to the gas valve, consisting of two push on 24V connectors, and two mains plugs. The LH mains plug is a push fit whilst the RH one is secured with a central fixing screw.
- 3 Unscrew the pilot pipe connector at the bottom, LHS of the gas valve.
- 4 Unscrew the burner manifold union. (Fig. 24)
- 5 Unscrew the four pozi-head screws securing the gas valve inlet pipe, and remove the gas valve complete with the outlet pipe.
- 6 Transfer the outlet pipe onto the new gas valve, using a new gasket. (Supplied with the valve.)
- 7 Fit the new gas valve assembly into the appliance using the other new gasket supplied on the valve inlet, and re-assemble in reverse order.
- 8 a) Relight the appliance, check for gas soundness, and recommission in accordance with section 5, 5.1, & 5.2. In addition it will be necessary to set the DHW and CH heat inputs, as follows:
  - b) Set the DHW input as follows:
    - i) Remove the sealing cap of the proportioning unit (C, Fig. 27) by rotating it 1/4 turn anticlockwise.
    - ii) Using a 10mm spanner, turn nut 'B' (Fig. 27) to attain the required DHW max burner pressure of 12.9 mbar (5.2inwg). Turn the nut clockwise to increase the pressure or anti-clockwise to decrease it.
    - iii) Check that the maximum pressure is correctly set by turning on and off the DHW inlet valve several times and ensuring that the pressure returns to that previously adjusted.
    - iv) Isolate the mains electricity supply and disconnect (pull off) the two 24V modulation leads (Fig. 18). Restore the mains supply. The appliance will light on minimum input only.

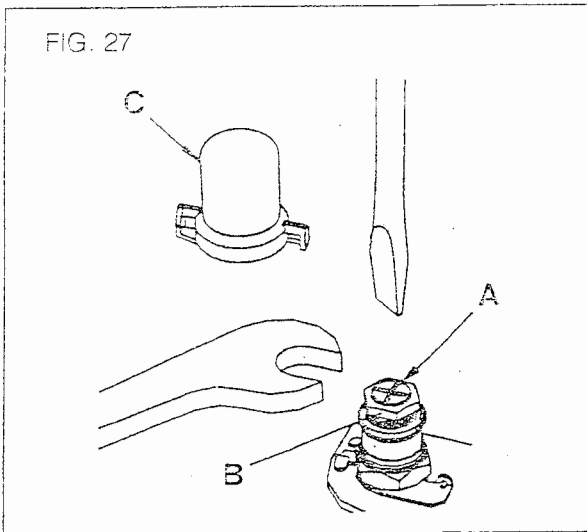

- v) Set the minimum pressure of 1.5 mbar by holding nut 'B' (Fig. 27) in position with a 10mm spanner and rotating the plastic screw 'A' with a screwdriver until the correct pressure is obtained. Turn the screw clockwise to increase the pressure or anti-clockwise to decrease it. It is essential that the max pressure has been set prior to adjusting the minimum pressure. Check that the minimum pressure is correctly set by turning on and off the DHW inlet valve several times and ensuring that the pressure returns to that previously adjusted.

- vi) Isolate the mains electricity supply and reconnect (push on) the two 24V modulation leads (Polarity is immaterial. Fig. 18). Restore the mains supply.

The appliance will light on maximum input. Check that the burner pressure is 12.9mbar (5.2inwg). (If it has changed repeat from step b(i)).

- vii) Refit the proportioning unit sealing cap. (C, Fig. 27).
- viii) Reduce the DHW draw off rate to the minimum necessary to maintain the burner alight by carefully adjusting the DHW Inlet valve and check that the burner pressure decreases in response to DHW temperature rise. Fully open the inlet valve.

- ix) Close the DHW tap and ensure that the burner is extinguished and the pump stops.

- c) Continue as in section 5.3 to 5.5.

### 9.7 PRESSURE SWITCH

*NOTE: Two types of pressure switch are available on this appliance, Honeywell or Huba. Both are fully interchangeable, and Fig. 23 shows the differences between them. Note that the Huba switch has a bracket not required by the Honeywell switch.*

- 1 Remove the outer casing and the sealed chamber front panel as described in section 6a, steps 1,2, and 3.
- 2 Disconnect the pressure sensing pipes from the switch.(Fig. 23.)
- 3 Disconnect the electrical connections from the switch.
- 4 Unscrew and remove the two screws securing the mounting bracket (Huba) or switch body (Honeywell). (Fig. 24)
- 5 (Huba only.) Remove the switch from the bracket (Two screws) and fit the new one.
- 6 Fit the new switch and re-assemble in reverse order referring to Fig. 23 and the wiring diagrams (Section 8) as appropriate.

### 9.8 LIMIT THERMOSTAT

The limit thermostat is situated on the top, LHS of the heat exchanger. (Fig. 24)

- 1 Remove the outer casing and the sealed chamber front panel as described in section 6a, steps 1,2, and 3.
- 2 Without disconnecting the wires, unscrew the two limit'stat fixing screws.
- 3 Lift the thermostat and fixing screws out using the wires.
- 4 Replace the thermostat and spread heat sink compound (supplied) over the base of the new one. Connect the wires, (polarity is

immaterial) and position the screws in the flange and re-fit using the wires to position the thermostat before tightening the screws.

- 5 Re-assemble in reverse order.

### 9.9 OVERHEAT THERMOSTAT

The overheat thermostat is positioned in a phial pocket alongside the air separator in the flow pipe. Fig. 24

- 1 Remove the outer casing as described in section 6a, steps 1 and 2.
- 2 From below the boiler, unscrew and remove the overheat thermostat locking nut to release the thermostat body. (Fig. 24)
- 3 Refer to Fig. 15. Remove the two screws (2) and pivot the control box downwards, then remove the two screws (1) and remove the control box cover.
- 4 Withdraw the thermostat then pull off the two electrical connections
- 5 Remove the lower 'key ring' securing the thermostat phial in its pocket and remove the phial by sliding it downwards. Withdraw the phial through the grommet in the control box.
- 6 Re-assemble in reverse order ensuring that the new phial is coated in heat sink compound (supplied) and correctly positioned and secured in it's pocket. Note that the electrical polarity is immaterial.

### 9.10 CH THERMISTOR

### 9.11 DHW THERMISTOR

The thermistors are screwed in fittings on the Flow Pipe (CH) and DHW Outlet pipe (DHW). The thermistors do not penetrate the waterways, therefore it is not necessary to drain the appliance. (Fig. 24)

- 1 Remove the outer casing as described in section 6a, steps 1 and 2.

Two types of thermistor connections are used on this appliance. Refer to fig 24 and look at the base of either thermistor. If the wires are moulded into the brass base, procede as below. If the thermistors have push on tab connections, go to step 2a.

- 2 Refer to Fig. 15. Remove the two screws (2) and pivot the control box downwards, then remove the two screws (1) and remove the control box cover.

- 3 Trace the thermistor wires from the sensor back to the PCB, and up to the other thermistor. Unclip the connector block from the PCB.

- 4 Unscrew both of the sensor units. Note that it is not necessary to drain the appliance. Pass the sensors through the grommet. The thermistor assembly is now no longer necessary.

- 5 Clip the 4 pole connector with cables to the PCB.

- 6 Pass the cables through the grommet.

- 7 Screw the sensor units using the heat sink compound supplied and push the faston connections of the cables onto the thermistor tabs. Ensure that the shortest cables are fitted to the DHW tapping.

- 8 Reassemble in reverse order.

- 2a (For thermistors with tab connections only:) Pull off both electrical connections from the faulty thermistor, unscrew the thermistor, replace and re-assemble in reverse order using the heat sink compound supplied. Note that the polarity of the thermistor connections is immaterial.

### 9.12 IGNITION PCB

- 1 Remove the outer casing as described in section 6a, steps 1 and 2.

- 2 Refer to Fig. 15. Remove the two screws (2) and pivot the control box downwards, then remove the two screws (1) and remove the control box cover.

- 3 Pull off the four connector blocks and the H.T. lead from the ignition PCB. (The RHS (smaller) PCB), then release the PCB from it's mountings.

- 4 Replace the PCB and reassemble in reverse order.

### 9.13 DRIVER PCB

- 1 Remove the outer casing as described in section 6a, steps 1 and 2.

- 2 Refer to Fig. 15. Remove the two screws (2) and pivot the control box downwards, then remove the two screws (1) and remove the control box cover.
- 3 Pull off the six connector blocks from the driver PCB (The LHS (larger) PCB).
- 4 Pull off the potentiometer control knobs (1 and 3, Fig. 19), and unscrew the locking nuts. Release the PCB from it's mountings by rotating the mounting pins 1/4 turn anticlockwise, and lift it out of the control box taking care not to lose the potentiometer spacers.
- 5 Replace the PCB and reassemble in reverse order Do not forget to re-fit the spacers.
- 4 Drain the DHW circuit by opening any DHW tap below the level of the boiler.
- 5 Refer to Fig. 15. Remove the two screws (2) and pivot the control box downwards
- 6 Disconnect all union connections to the DHW heat exchanger and remove the heat exchanger.
- 7 Fit new heat exchanger and reassemble in reverse order using the new gaskets supplied with the heat exchanger. Refill and re-commission the system as described in section 5.1.

#### 9.14 PUMP

- 1 Remove the outer casing as described in section 6a, steps 1 and 2.
- 2 Isolate the CH flow and return valves ('D' & 'F', Fig. 3), and drain the appliance through the drain plug situated below the pump.
- 3 Swivel the pump and remove the plastic pump cover (1 Screw) Disconnect the electrical connections to the pump.
- 4 Support the pump to prevent it from rotating, and unscrew both union connections.
- 5 Replace the pump, and reassemble in reverse order, using the new gaskets supplied with the pump. If the new pump is fitted with a speed adjuster, ensure that the speed is set to Maximum.
- 6 Refill and commission the system as described in section 5.1.

#### 9.15 DHW HEAT EXCHANGER

- 1 Remove the outer casing as described in section 6a, steps 1 and 2.
- 2 Isolate the CH flow and return valves, and the DHW isolation valve ('D', 'F', & 'B' Fig. 3).
- 3 Drain the appliance through the drain plug situated below the pump and the drain point at the bottom of the DHW heat exchanger.

#### 9.16 DIVERTOR VALVE.- COMPLETE

- 1 Remove the outer casing as described in section 6a, steps 1 and 2.
- 2 Isolate the CH flow and return valves, and the DHW isolation valve ('D', 'F', & 'B' Fig. 3).
- 3 Drain the appliance through the drain plug situated below the pump outlet and the drain point at the bottom of the DHW heat exchanger. Rotate the pump to the RHS to improve access to the divertor valve.
- 4 Drain the DHW circuit by opening any DHW tap below the level of the boiler.
- 5 Refer to Fig. 15. Remove the two screws (2) and pivot the control box downwards.
- 6 Disconnect all union connections from the divertor valve. Withdraw the valve and remove the electrical connections.
- 7 Transfer the electrical connections onto the new valve. Refer to the wiring diagrams in section 8.
- 8 Re-assemble in reverse order, using the new gaskets supplied with the valve. Refill and re-commission the system as described in section 5.1.

#### 9.17 DIVERTOR VALVE - MICROSWITCH ASSEMBLY

- 1 Remove the outer casing as described in section 6a, steps 1 and 2.
- 2 Rotate the pump to improve access to the divertor valve.



- 3 Pull out the microswitch circlip, (Fig. 20) and lift off the microswitch assembly.
- 4 Transfer the electrical connections onto the new microswitch assembly. Refer to the wiring diagrams in section 8.
- 5 Re-assemble in reverse order.

#### 9.18 C.H.EXPANSION VESSEL

In the unlikely event of failure of the expansion vessel diaphragm it is acceptable to leave the vessel in position and to fit a replacement vessel (of similar or greater capacity) external to the appliance but as close as possible to the CH return. Alternatively the vessel can be replaced as follows. Note replacement is not recommended if a rear flue outlet is used or if the clearance above the casing is less than 300mm.

- 1 Remove the outer casing as described in section 9.1, steps 1 and 2.
- 2 Isolate the CH flow and return valves ('D' & 'F', Fig. 3), and drain the appliance through the drain plug situated below the pump
- 3 Unscrew the expansion vessel pipe union at it's connection with the DHW heat exchanger.
- 4 Remove the two screws securing the expansion vessel bracket at the top, rear of the appliance.
- 5 If a rear flue outlet is used it is necessary to disengage the flue and air duct temporarily. Refer to section 4.5.
- 6 Remove the adjusting screws (5, fig 8) on the wall mounting bracket thereby allowing the appliance to move slightly forwards at the top.
- 7 Lift the expansion vessel, bracket, and pipe out of the appliance through the top.
- 8 Transfer the bracket and pipe to the new expansion vessel, and re-assemble in reverse order. Re-pressurise and re-commission the system as described in section 5.1.

#### 9.19 SUMMER/WINTER SWITCH

- 1 Remove the outer casing as described in section 6a, steps 1 and 2.

- 2 Refer to Fig. 15. Remove the two screws (2) and pivot the control box downwards, then remove the two screws (1) and remove the control box cover.
- 3 Squeeze the switch to depress the retaining clips, then withdraw the switch forwards.
- 4 Pull off the connections to the switch.
- 5 Fit the new switch and reassemble in reverse order, with reference to the wiring diagrams in section 8.

#### 9.20 PRESSURE/TEMPERATURE GAUGE

- 1 Remove the outer casing as described in section 6a, steps 1 and 2.
- 2 Refer to Fig. 15. Remove the two screws (2) and pivot the control box downwards.
- 3 Isolate the CH flow and return valves (D & F Fig. 3).
- 4 Drain the appliance through the drain point situated below the pump.
- 5 Remove the 'key ring' and the temperature sensor from its pocket (Fig. 24) and unscrew the pressure sensor from the top of the safety valve.
- 6 Squeeze the gauge to depress the retaining clips, then ease the gauge forwards.
- 7 Reassemble in reverse order. Refil and recommission the system as described in section 5.1

#### 9.21 SAFETY VALVE

- 1 Remove the outer casing as described in section 6a, steps 1 and 2.
- 2 Refer to Fig. 15. Remove the two screws (2) and pivot the control box downwards.
- 3 Isolate the CH flow and return valves (D & F Fig. 3).
- 4 Drain the appliance through the drain point situated below the pump.
- 5 Unscrew the pressure sensor from the top of the safety valve.

- 6 Unscrew the union supporting the outlet pipe from the valve, and remove the valve by unscrewing it from the main pipe connection.
- 7 Fit the new safety valve using a suitable jointing compound and reassemble in reverse order. Refill and recommission the system as described in section 5.1

### 9.22 AUTOMATIC AIR VENT

- 1 Remove the outer casing front panel as described in section 6a, step 1.
- 2 Refer to fig 9.  
Remove the casing RH side panel by unscrewing the two fixing screws.
- 3 Isolate the CH flow and return valves (D & F Fig. 3).
- 4 Drain the appliance through the drain point situated below the pump.
- 5 Unscrew the automatic air vent.
- 6 Fit the new automatic air vent using a suitable jointing compound and reassemble in reverse order.  
Refill and recommission the system as described in section 5.1.

### 9.23 VIEWING WINDOW

- 1 Remove the outer casing and sealed chamber front panel as described in section 6a, steps 1,2, and 3.
- 2 Unscrew the three screws and nuts securing the viewing window.
- 3 Replace the viewing window and gaskets, and reassemble in reverse order.

### 9.24 DHW EXPANSION VESSEL - IF FITTED

- 1 Remove the outer casing as described in section 6a, steps 1 and 2.
- 2 Isolate the DHW isolation valve ('B' Fig. 3).
- 3 Drain the DHW circuit by opening any DHW tap below the level of the boiler.

- 4 Unscrew the DHW expansion vessel and replace with the new one, using a jointing compound suitable for potable water.

- 5 Reassemble in reverse order.

### 9.25 TIME CLOCK

- 1 Remove the outer casing as described in section 6a, steps 1 and 2.
- 2 Remove the plastic cover on the clock face by rotating clockwise 1/8 turn and pulling forwards.
- 3 Unscrew the single screw at the bottom RHS of the clock face.
- 4 Refer to Fig. 15. Remove the two screws (2) and pivot the control box downwards, then remove the two screws (1) and remove the control box cover.
- 5 Pull off the connection base at the back of the clock.
- 6 Pull to open the plastic tabs at each side of the clock and pull the clock forwards through the hole in the fascia panel.
- 7 Re-assemble in reverse order and test the operation of the new clock. Set it to the desired settings.

### 9.26 TIME CLOCK OVERRIDE SWITCH

- 1 Follow the procedure described for the Summer/Winter switch. (Section 9.19)

# 10 REPLACEMENT PARTS

FIG. 28

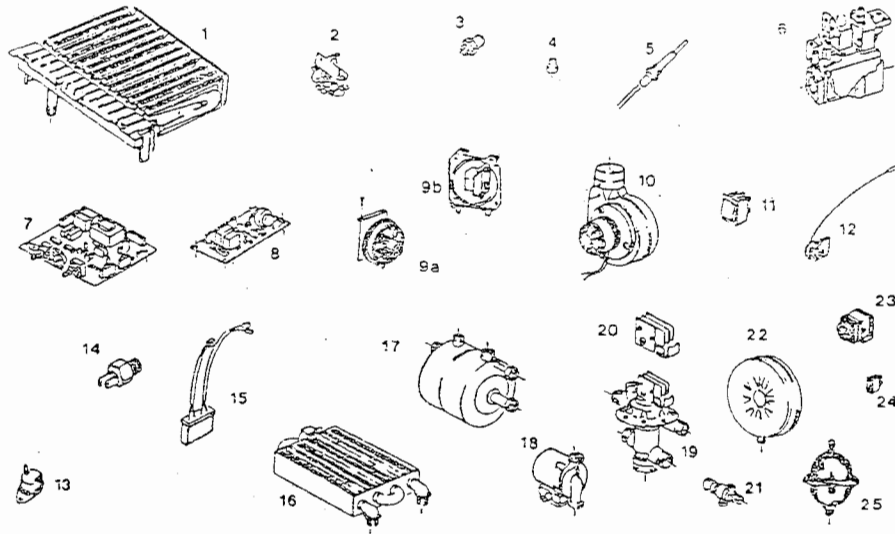

KEY	G.C.PART NO	DESCRIPTION	NO OFF	MAKER'S PT NO
1	309 328	MAIN BURNER Polidoro: SIME 5172700	1	5172700
2	379 588	PILOT BURNER Polidoro PA 646 F/G 29	1	6223103
3	397 950	MAIN INJECTOR Polidoro NP 130	13	6154402
4	397 949	PILOT INJECTOR Polidoro G29	1	6066102
5	309 329	ELECTRODE Sappco: SIME 6023002	1	6023002
6		MULTIFUNCTIONAL GAS CONTROL Sit 0.827.110	1	6245201
7	309 330	DRIVER PCB SIME 6230655	1	6230655
8	397 586	IGNITER PCB Pactrol 414200 ISS01	1	6230605
8	397 595	IGNITER PCB Honeywell S458B 1002	1	A6230605
9	386 115	AIR PRESSURE SWITCH Honeywell C6065 F1043	1	6225702
9	397 596	AIR PRESSURE SWITCH Huba 602.99 157	1	A6225702
10	397 585	FAN ASSEMBLY Sifan S4577	1	6225603
10	397 592	FAN ASSEMBLY Salmson E1598 DR	1	A6225603
11	397 594	SUMMER/WINTER SWITCH Signal Lux 8226292065	1	6013400
12	397 597	OVERHEAT THERMOSTAT Ranco LM7 P5041 (Man. Reset)	1	6173200
13	397 590	LIMIT THERMOSTAT Elmwood L100C 2455R-98-775	1	6146700
14		CH-DHW THERMISTOR SIME	2	6231350
15		THERMISTOR CABLE ASSEMBLY SIME	1	6241435
16	309 331	HEAT EXCHANGER Giannoni PFPR 163	1	6222902
17	309 332	DHW HEAT EXCHANGER Giannoni PFA 26-60	1	6222803
18	397 598	PUMP Wilo RS 25/70 EM	1	6132102
18	385 808	PUMP Euramo GOLD STAR	1	B6132102
19	397 951	DIVERTOR VALVE Giannoni V33/1M/1D/4A-1N	1	6102802
20	397 952	MICROSWITCH ASSEMBLY OMRON V151C5	1	5143300
21	397 677	SAFETY VALVE Caleffi 3141	1	6042201
22	397 584	CH EXPANSION VESSEL Zilmet 317894 7L 531	1	5139100
23	397 928	TIME CLOCK Grasslin UNI 45 TE 240V - 50Hz	1	6197701
24	397 599	CLOCK OVERRIDING SWITCH Signal Lux 8116502036	1	6130101
25	394 247	DHW EXPANSION VESSEL Cimm CAR 19 1/4"	(1 OPTIONAL)	6245100
25	385 190	DHW EXPANSION VESSEL Zilmet Z160	(1 OPTIONAL)	A6245100

---

**HALSTEAD BOILERS Ltd**  
**4 FIRST AVENUE, BLUEBRIDGE IND. ESTATE,**  
**HALSTEAD, ESSEX CO9 2EX**

**TEL. 0787-475557, FAX 0787-474588**

---