



# Glow-worm

## Instructions for Use Installation and Servicing

To be left with the user

### Hideaway 60

G.C. No. 41 313 13

*Open Flue Boiler*



This is a Cat I<sub>2H</sub> Appliance

Reference in these instructions to British Standards and Statutory Regulations/Requirements apply only to the United Kingdom. For Ireland the rules in force must be used.

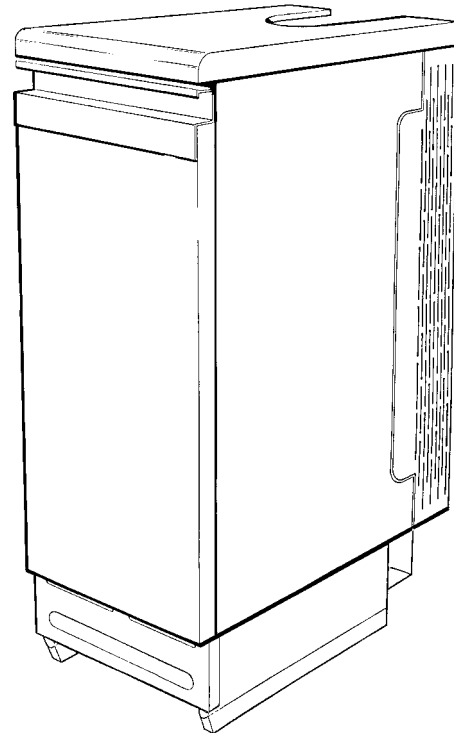

1037

*The instructions consist of three parts, User, Installation and Servicing Instructions, which includes the Guarantee Registration Card. The instructions are an integral part of the appliance and must, to comply with the current issue of the Gas Safety (Installation and Use) Regulations, be handed to the user on completion of the installation.*

### Guarantee Registration

Thank you for installing a new Glow-worm appliance in your home.

Glow-worm appliances' are manufactured to the very highest standard so we are pleased to offer our customers' a Comprehensive First Year Guarantee.

In the center pages are to be found your Guarantee Registration Card, which we recommend you complete and return as soon as possible.

If this card is missing you can obtain a copy or record your registration by telephoning the Heatcall Customer Service number 01773 828100.

Our Guarantee gives you peace of mind plus valuable protection against breakdown by covering the cost of:

- All replacement parts**
- All labour charges**
- All call-out charges**

REGISTER YOUR GLOW-WORM APPLIANCE  
FOR 1ST YEAR GUARANTEE PROTECTION

**CALL 0208 247 9857**

**HEATCALL** Customer Services:  
Tel: (01773) 828100  
**One Contact Local Service** Fax: (01773) 828070

**Hepworth Heating Ltd.,**  
Nottingham Road, Belper, Derbyshire. DE56 1JT  
**General/Sales enquiries:**  
Tel: (01773) 824141 Fax: (01773) 820569

## Important Information

### Notes and General Information

Please read these instructions and follow them carefully for the safe and economical use of your boiler.

The boiler is automatic in operation, once the pilot is lit and the controls have been set.

Glow-worm Hideaways' are central heating boilers, to provide heating and if required an indirect domestic hot water supply.

### Important Notice

This boiler is for use only on G20 gas.

### Gas Safety (Installation and Use) Regulations

In your own interests and that of safety, it is the Law that ALL gas appliances are installed by a competent person in accordance with the current issue of the above regulations.

### CE Mark

This boiler meets the requirements of Statutory Instrument, No. 3083 The Boiler Efficiency Regulations, and therefore is deemed to meet the requirements of Directive 92/42/EEC on the efficiency requirements for new hot water boilers fired with liquid or gaseous fuels.

Type test for purposes of Regulation 5 certified by:

Notified body 0086.

Product/production certified:

Notified body 0086.

The CE Mark on this appliance shows compliance with:

1. Directive 90/396/EEC on the approximation of the Laws of the Member States relating to appliances burning gaseous fuels.

2. Directive 73/23/EEC on the harmonization of the Laws of the Member States relating to electrical equipment designed for use within certain voltage limits.

3. Directive 89/336/EEC on the approximation of the Laws of the Member States relating to electromagnetic compatibility. Information for the Installer and Service Engineer.

### Control of Substances Hazardous to Health

Under Section 6 of The Health and Safety at Work Act 1974, we are required to provide information on substances hazardous to health.

The adhesives and sealants used in this appliance are cured and give no known hazard in this state.

### Insulation Pads/Ceramic Fibre, Glassyarn

These can cause irritation to skin, eyes and the respiratory tract.

If you have a history of skin complaint you may be susceptible to irritation. High dust levels are usual only if the material is broken.

Normal handling should not cause discomfort, but follow normal good hygiene and wash your hands before eating, drinking or going to the lavatory.

If you do suffer irritation to the eyes or severe irritation to the skin seek medical attention.

### Boiler Thermostat

These contain very small amounts of xylene in the sealed phial and capillary. If broken, under normal circumstances the fluid does not cause a problem, but in cases of skin contact, wash with cold water.

If swallowed drink plenty of water and seek medical attention.

CONTENTS	DESCRIPTION	SECTION	PAGE No.
<b>INSTRUCTIONS FOR USE</b>	Introduction		3
	Lighting the Boiler		4
<b>INSTALLATION INSTRUCTIONS</b>	General Data	1	5
	Water Systems	2	7
	Flue and Ventilation	3	8
	Installation	4	9
	Casing Location	5	11
	Electrical Wiring	6	11
	Commissioning	7	12
<b>SERVICING INSTRUCTIONS</b>	Servicing	8	15
	Replacement Parts	9	17
	Fault Finding	10	20
	Spare Parts	11	24

# Instructions for Use

## Warning

Make sure that nothing obstructs the rear side grilles or clearances. See diagram 1.2 and 1.3 for minimum clearances.

## Boilers Installed in a Compartment

If the boiler is fitted in a compartment, cupboard etc., do not obstruct the purpose built compartment vents or grille on the boiler.

Do not use the compartment for storage purposes.

## Maintenance

To ensure the continued efficient and safe operation of the boiler it is recommended that it is checked and serviced at regular intervals. The frequency of servicing will depend upon the particular installation conditions and usage, but in general once a year should be enough.

If this appliance is installed in a rented property there is a duty of care imposed on the owner of the property by the current issue of the Gas Safety (Installation and Use) Regulations, Section 35.

It is the law that servicing is carried out by a competent person.

To obtain service please call your installer or Heatcall (Glow-worm's own service organisation) using the telephone number given on the inside of the front panel.

Please be advised that the 'Benchmark' logbook should be completed by the installation engineer on completion of commissioning and servicing.

All CORGI Registered Installers carry a CORGI ID card, and have a registration number. Both should be recorded in your boiler Logbook. You can check your installer is CORGI registered by calling CORGI direct on :- 01256 372300.

## Boiler Electrical Supply

**WARNING.** This boiler must be earthed.

The boiler must only be connected to a 240V~50Hz supply, protected by a 3A fuse, maximum.

All wiring must be in accordance with the current issue of BS7671.

Heat resistant cable having a conductor size of 0.75mm<sup>2</sup>, (24/0.22mm), to BS6500 Table 16 must be used.

## To Connect an Electrical Plug

The colours of three core flexible cable are, Brown - live, Blue - neutral, Green and yellow - earth.

As the markings on your plug may not correspond with these colours continue as follows:

The wire coloured brown must be connected to the terminal marked "L" or Red.

The wire coloured blue must be connected to the terminal marked "N" or Black.

The wire coloured green and yellow must be connected to the terminal marked "E", Green or the earth symbol  $\oplus$ .

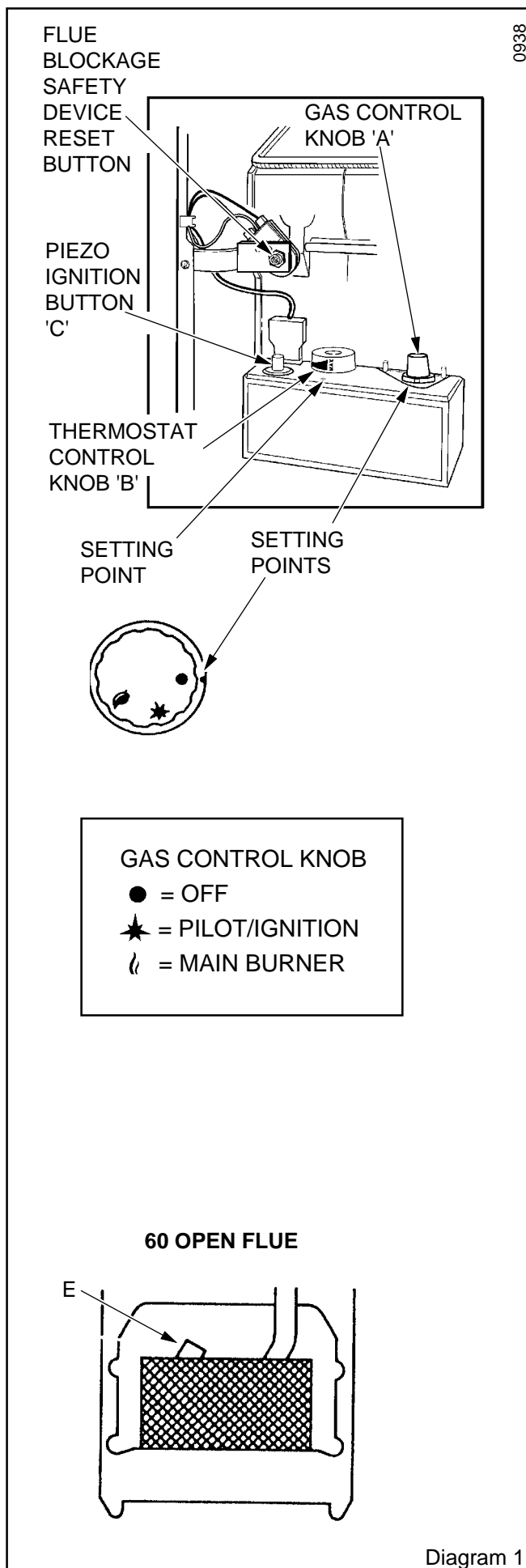

## Instructions for Use

### Safety Device

This appliance is fitted with a flue blockage safety device which will shut down the appliance in the event of abnormal flue conditions. This device is NOT a substitute for an independently mounted Carbon Monoxide detector.

The safety device is reset, after three minutes, by pushing in the button shown in diagram 1.

Shut down can occur during certain climate conditions, but if it recurs the chimney flue and air inlet into the room must be checked and any problems found corrected by a competent person, before the boiler is used again.

### To Light the Boiler

**WARNING.** If the pilot light goes out for any reason, do not attempt to relight until three minutes have gone by.

Remove the door by pulling forwards with the fascia at the top. Lift up to free from bottom side lugs.

Refer to diagram 1 to identify the controls.

Check that the mains electrical supply to the boiler is switched OFF.

Check that the Flue Blockage Safety Device has not operated, that is, the button is in. Refer to Safety Device instructions.

Push in slightly and turn gas control knob "A" clockwise until '●' is against its setting point.

Turn thermostat control knob "B" anticlockwise until "O" is against its setting point.

Push in slightly and turn gas control knob "A" anticlockwise until '★' is against its setting point, then push fully and hold in.

Push and release piezo ignition button "C" until the pilot burner lights.

Air may be present in the supply pipe so the lighting of the pilot may need to be repeated until all the air has been expelled.

When the pilot is alight, view through window "E", keep gas control knob "A" fully pushed in for about 15 seconds, then release.

If the burner fails to stay alight, wait three minutes, then repeat the lighting procedure only now keep control knob "A" depressed for a little longer before releasing. The Flue Blockage Safety Device may also need resetting, refer to instructions above.

If the gas control knob "A" is turned to '●', a safety lock prevents it being turned on again for a short period. No attempt should be made to relight the pilot for at least three minutes.

Make sure that the pilot is alight and stable, then switch on the electrical supply.

Press in and turn gas control knob "A" anticlockwise until '⌋' is against its setting point.

Set any remote controls to call for heat.

Turn the boiler thermostat knob "B" clockwise until "MAX" is against its setting point and the main burner will light. Adjust thermostat to required setting between "MIN" and "MAX". "MAX" is about 82°C (180°F).

Refit the door by fitting the hooked runner at the bottom into the slot in the side panels and pushing onto the studs.

### To Turn the Boiler Off

For short periods. Turn the boiler thermostat control knob "B" anticlockwise to "O". The pilot will remain alight. To relight the main burner turn the thermostat control knob "B" clockwise to the desired setting between "MIN" and "MAX".

For longer periods. Push in slightly and turn gas control knob "A" fully clockwise until '●' is against its setting point. Turn thermostat control knob "B" anticlockwise to "O". Isolate the boiler from the electrical supply. Follow the full lighting procedure to relight.

Refer also to "Protection Against Freezing".

### Gas Leak or Fault

If a gas leak or fault exists or is suspected the boiler must be turned off, including the electrical supply and must not be used until the fault has been put right. Advice/help should be obtained from the local gas undertaking or your installation/servicing company.

### Protection Against Freezing

If the boiler is to be out of use for any long period of time during severe weather conditions we recommend that the whole of the system including the boiler, be drained off to avoid the risk of freezing up. If an immersion heater is fitted in the domestic hot water cylinder make sure it is switched off.

### Sheet Metal Parts

**WARNING.** This appliance contains metal parts (component) and care should be taken when handling and cleaning, with particular regard to edges.

### Cleaning

Keep the casing clean by wiping it over occasionally with a damp soapy cloth and dry with a polishing cloth.

Do not use abrasive cleaners.

### Replacement Parts/Boiler Identification

If replacement parts are required apply to your local supplier or gas undertaking. Please quote the name of the boiler and its serial number which can be found on the data label positioned on the boiler top, to the rear of the inclined flueway cleaning door.

### Clearance

Minimum clearances must be left around the boiler as shown in diagram 1.2 and 1.3.

# 1 General

0993

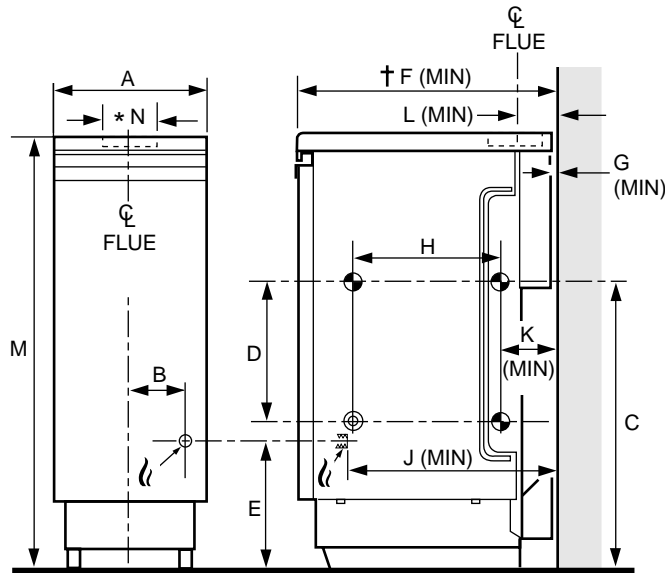

- † A SPECIAL TOP CASING TO SUIT 600mm (23<sup>5</sup>/<sub>8</sub> in.) WORKTOPS IS AVAILABLE
- ℓ GAS CONNECTION Rc 1/2 (1/2 in. B.S.P.T.)
- ⊕ WATER CONNECTIONS Rc1 (1in. B.S.P.T.)
- ⊙ WATER CONNECTIONS Rc1 reduced with DISTRIBUTOR TUBE to Rc 3/4 (3/4 in. B.S.P.T.) (pumped return)
- \* INSIDE DIAMETER OF SOCKET FOR 100mm (4in.) NOMINAL DIAMETER FLUE TO BS567

GENERAL DIMENSIONS - given in millimetres (Approx. inches)

Diagram 1.1

	A	B	C	D	E	†F	G	H	J	K	L	M	N		
mm	300	118	598	294	265	533	3	300	445	121	88	900	115		
in.	11 <sup>3</sup> / <sub>4</sub>	4 <sup>5</sup> / <sub>8</sub>	23 <sup>1</sup> / <sub>2</sub>	11 <sup>1</sup> / <sub>2</sub>	10 <sup>1</sup> / <sub>2</sub>	21	1/8	11 <sup>3</sup> / <sub>4</sub>	17 <sup>1</sup> / <sub>2</sub>	4 <sup>3</sup> / <sub>4</sub>	3 <sup>1</sup> / <sub>2</sub>	35 <sup>1</sup> / <sub>2</sub>	4 <sup>1</sup> / <sub>2</sub>		

## Sheet Metal Parts

Warning. When installing or servicing this boiler care should be taken when handling sheet metal parts, to avoid the possibility of personal injury.

## Important Notice

This boiler is for use only on G20 gas.

Wherever possible, all materials, appliances and components to be used shall comply with the requirements of British Standards.

Where no British Standards exist, materials and equipment should be fit for their purpose and of suitable quality and workmanship.

## 1.1 Data

**Approx. weight of boiler:** 76kg (168 lb)

**Water content:** 5.76litre (1.27 gal)

**Gas connection:** Rc1/2(1/2 BSP)

**Water connection:** Rc1 (1inch BSP)

**Electrical supply:** 240V - 50Hz fused at 3A

**Burner:** Aeromatic

The Seasonal Efficiency Domestic Boilers UK (SEDBUK) is 71.3%.

The value is used in the UK Government's Standard Assessment Procedure (SAP) for energy rating of dwellings. The test data from which it has been calculated have been certified by B.S.I.

## 1.2 Range Rating

This boiler is range rated and may be adjusted to suit individual systems. The table gives settings and outputs.

The boiler input is supplied preset to maximum and should be adjusted to suit system requirements.

## HIDEAWAY 60

RANGE RATING	min	medium	max
NOMINAL HEAT INPUT (GROSS) <i>kW</i>	18.79	19.97	21.15
<i>Btu/h</i>	64,100	68,140	72,160
NOMINAL HEAT OUTPUT <i>kW</i>	14.65	15.68	16.7
<i>Btu/h</i>	50,000	53,000	57,000
BURNER SETTING PRESSURE (HOT) <i>mbar</i>	10.0	11.2	12.4
<i>in. w.g</i>	4.0	4.5	5.0
INJECTOR	3.9mm - 205751		

## 1.3 Statutory Requirements

The installation of this boiler must be carried out by a competent person in accordance with the relevant requirements of the current issue of:

Manufacturer's instructions, supplied.

The Gas Safety (Installation and Use) Regulations, The Building Regulations, Local Water Company Byelaws, The Building Standards (Scotland) Regulations, applicable in Scotland, The Health and Safety at Work Act, The Control of Substances Hazardous to Health, The Electricity at Work Regulations and any applicable local regulations.

Detailed recommendations are contained in the current issue of the following British Standards and Codes of Practice:

BS6798, BS5440 Part 1 and 2, BS5449, BS6700, BS6891, BS5546, BS7478, BS7593, BS7671.

Manufacturer's instructions must not be taken as overriding statutory requirements.

# 1 General

## 1.4 B.S.I. Certification

This boiler is certificated by B.S.I. for safety and performance. It is, therefore, important that no alteration is made to the boiler unless approved, in writing, by Hepworth Heating Ltd.

Any alteration not approved by Hepworth Heating Ltd., could invalidate the B.S.I. certification, boiler warranty and could also infringe the statutory requirements.

## 1.5 Gas Supply

The gas installation shall be in accordance with the current issue of BS6891.

The supply from the governed meter must be of adequate size to provide a steady inlet working pressure of 20mbar (8in wg) at the boiler.

On completion test the gas installation using the pressure drop method and suitable leak detection fluid, purge in accordance with the current issue of BS6891.

## 1.6 Electrical

Warning. This boiler must be earthed.

The electrical installation must be carried out by a competent person. All external components must be of the approved type and must be connected in accordance with the current issue of BS7671 and any local regulations which may apply.

Connection of the boiler and any system controls to the mains supply should be through a 3A fused double pole isolating switch, having a minimum double pole contact separation of 3mm, serving only the boiler and system controls.

Heat resistant flexible cable of at least 0.75mm<sup>2</sup>, to the current issue of BS6500 Table 16 must be used for all connections within the boiler casing.

## 1.7 Boiler Location

The boiler must not be installed in a room used or intended to be used as sleeping accommodation or a room containing a bath or shower.

This boiler is not suitable for installation out of doors.

The boiler must stand on a level floor, conforming with local authority requirements and building regulations. The base temperature is within the requirements of the current issue of BS5258. The boiler may be stood on a wooden floor but a metal plate is required to protect plastic tiles and similar floor coverings.

Suitable clearance needs to be available at the sides of the boiler to ease connection of pipework. The actual clearances will vary according to site conditions.

When the boiler is to be installed level with work surfaces, minimum clearances to fixtures, walls and the like should be provided, see diagram 1.2.

To ease minimum clearances it may be necessary to modify units or fixtures.

A front access clearance should be provided as shown in diagram 1.3.

The minimum gap behind the top casing is dimension "G" in diagram 1.1. The boiler can be sited further away from the wall if required to align with kitchen units.

Combustible wall material must be 25mm (1in) away from flue components.

A special top casing, part number 424858 can be bought, to enable boiler casings to be arranged flush with 600mm (23<sup>7</sup>/<sub>8</sub>in) deep worktops.

Where the installation of the boiler will be in an unusual location, special procedures may be necessary, the current issue of BS6798 gives detailed guidance on this aspect.

A compartment used to enclose the boiler must be designed and constructed specifically for this purpose. An existing cupboard or compartment modified for the purpose may be used. Details of essential features of cupboard and compartment design are given in the current issue of BS6798.

Make sure that nothing will obstruct the side clearances or side grilles. If installing the boiler in a compartment make sure that openings and vents are not obstructed.

## 1.8 Heating System Controls

The heating system should have installed: a programmer and room thermostat controlling the boiler.

Thermostatic radiator valves may be installed in addition to the room thermostat.

Note: For further information, see The Building Regulations 1991 - Conservation of fuel and power, 1995 edition - Appendix G, table 4b.

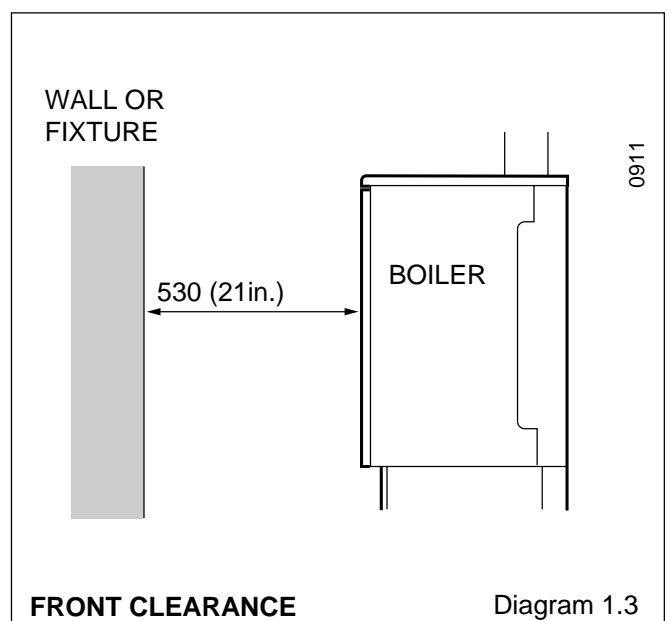
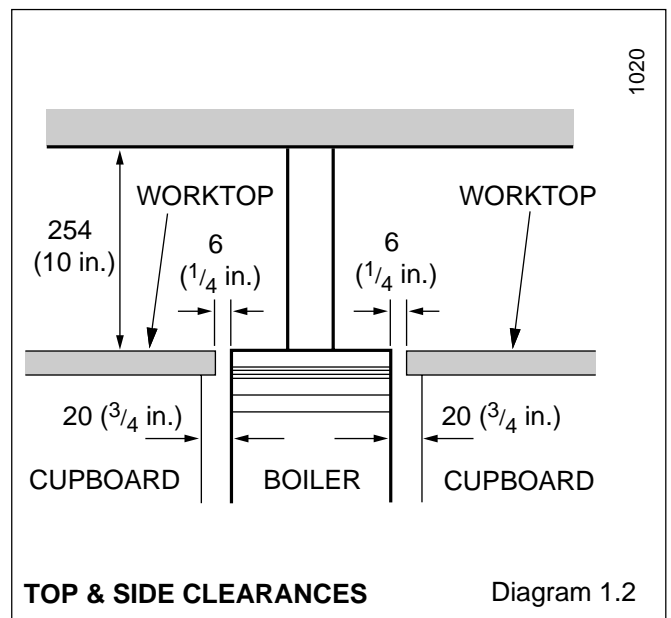



## 2 Water Systems

### 2.1 Water Pressure Head

This boiler must not be connected to a sealed water system.

This boiler shall only be connected to an open vented cistern water supply, with a minimum head of 1metre (39in) and a maximum of 27metre (90ft).

### 2.2 Inhibitor

Attention is drawn to the current issue of BS5449 and BS7593 on the use of inhibitors in central heating systems.

If an inhibitor is to be used in the system contact should be made with a manufacturer so that they can recommend their most suitable product.

If using in an existing system take special care to drain the entire system, including the radiators, then thoroughly cleaning out before fitting the boiler, whether or not adding an inhibitor.

### 2.3 Gravity Domestic Hot Water and Pumped Central Heating

It is recommended that a cylinder thermostat is used to prevent the stored water temperature becoming too high when the heating pump is off.

The domestic hot water primary flow and return must be 28mm od. The installation must comply with the current issue of BS5546 and BS6700, see diagram 2.1.

If the above conditions cannot be met, it is suggested that a fully pumped system is used.

### 2.4 Pumped Central Heating and Domestic Hot Water

Where a single flow and return is taken from the boiler, a minimum static head of 1metre (39in) must be provided between the water level in the cold water cistern and the centre of the waterway, see diagram 2.2.

### 2.5 Circulation Pump

Normally the pump should be set to give a temperature difference of 11°C (20°F), across the boiler. At the appropriate flow rate the resistance through the boiler can be found by reference to the pressure loss graph, diagram 2.3.

Use a pump with integral valves or fit valves as close to the pump as possible.

### 2.6 Domestic Hot Water Cylinder

For all systems supplying domestic hot water the cylinder must be indirect.

### 2.7 Safety Valve

A safety valve need not be fitted to an open vented system.

### 2.8 Draining Tap

A drain tap must be fitted at the lowest points of the system which will allow the draining of the entire system, including the boiler and domestic hot water cylinder.

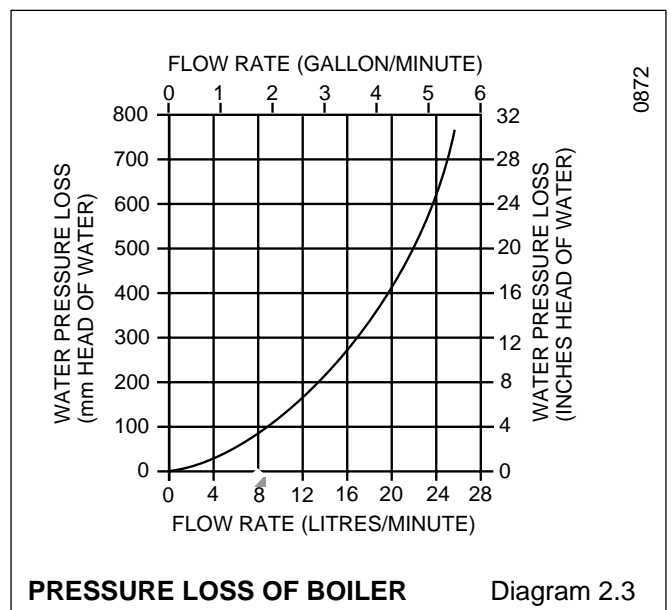
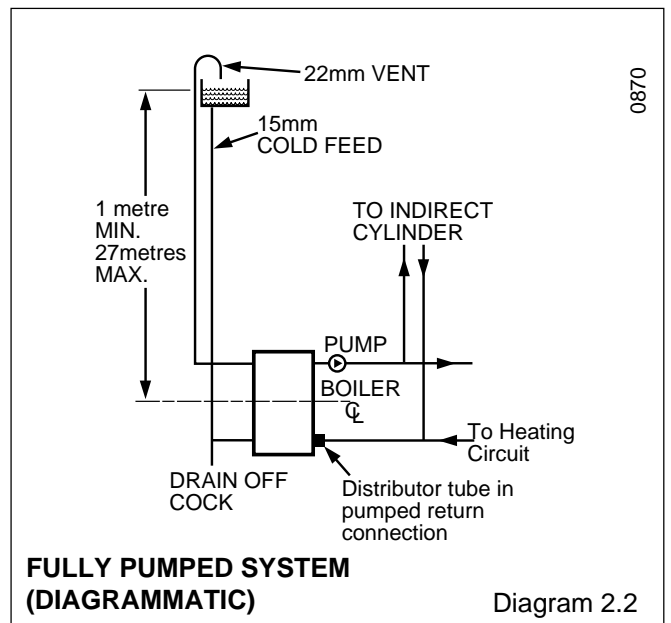
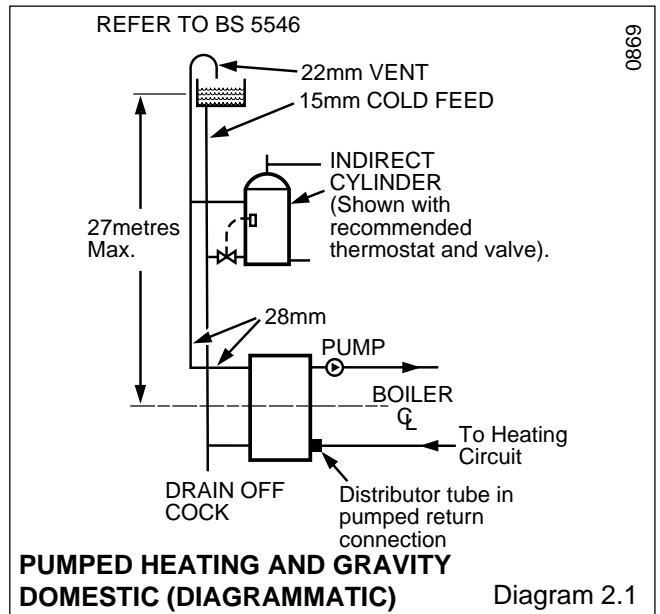

## 3 Flue and Ventilation

### Important Note

The boiler is fitted with a Flue Blockage Safety Device, which will shut down the boiler if there is an unacceptable spillage of products at the draught diverter.

This safety device MUST NOT under any circumstances be interfered with or put out of action. The safety device must only be replaced with the Glow-worm parts.

### 3.1 Flue

The integral draught diverter on the Hideaway range of boilers makes the combustion performance independent of conditions in the secondary flue, but in common with other fuels an efficient flue is necessary to make sure of a trouble free installation.

The flue must be at least equivalent to 1m vertical.

The boiler flue socket is designed to take flue pipes to the current issue of BS567. If a flue pipe to BS715 is to be used, an adapter must be fitted to the boiler flue socket, as diagram 1.1.

The flue must be in accordance with the current issue of BS5440 Part 1.

### 3.2 Flue Guidelines

The flue should be kept as short as possible. Horizontal or very shallow runs of the flue should be avoided as they encourage local cooling.

Always choose a flue route which will cause the least cooling of the flue.

There should be a vertical rise of at least 600mm (2ft) before using a bend. 90° elbows should not be used.

End with a certificated flue terminal, preferably above ridge height, but at least above the eaves of a pitched roof.

An existing chimney must be thoroughly swept and all debris cleared away before lining.

### 3.3 Timber Frame Buildings

If the boiler is to be installed in a timber frame building it should be fitted in accordance with the Institute of Gas Engineers document IGE/UP/7/1998. If in doubt seek advice from the local gas undertaking or Hepworth Heating Ltd.

### 3.4 Ventilation for Boiler Installed in a Room or Space

If the boiler is to be installed in a room or space a purpose designed permanent ventilation opening, to supply air for combustion, must be provided on an outside wall to external air, refer to the current issue of BS5440 Part 2 for details.

The opening may be directly into the room or the space containing the boiler, or an outside wall of an adjacent room or space which has an internal permanent air vent, of the same size, into the room or space containing the boiler.

Do not ventilate through a bedroom, bedsitting room, private garage or a room containing a bath or shower.

When the boiler is installed in a room or internal space already containing other fuel burning appliances then the air supply of such appliances must be taken into account.

The ventilation opening areas are given in "Air Vent Table A". The figures quoted refer to the minimum acceptable effective area.

### 3.5 Ventilation for Boilers Installed in a Cupboard or Compartment

When the boiler is fitted in a cupboard or compartment, high and low level purpose designed, permanent openings must be provided to supply air for combustion and compartment ventilation.

The air vents must have minimum areas in accordance with "Compartment Air Vent B". The figures quoted refer to the minimum acceptable effective area.

Both the high and low level openings must communicate with the same room, or must both be on the same wall to outside air.

If air vent grilles are fitted to a cavity wall, the opening through the wall must be ducted.

Where ventilation air to a compartment is taken from a room or space, then the room or space must be fitted with a ventilation opening as specified in "Air Vent Table A".

For information regarding compartment requirements refer to the appropriate section of the current issue of BS6798.

AIR VENT TABLE 'A' FOR ROOM/SPACE INSTALLATIONS		
EFFECTIVE AREA OF VENT	cm <sup>2</sup>	71
	in <sup>2</sup>	11

COMPARTMENT AIR VENT TABLE 'B'				
COMPARTMENT VENTILATION REQUIREMENTS	HIGH LEVEL VENT AREA		LOW LEVEL VENT AREA	
	VENTILATION FROM ROOM OR SPACE	205cm <sup>2</sup>	32in <sup>2</sup>	409cm <sup>2</sup>
FROM OUTSIDE	103cm <sup>2</sup>	16in <sup>2</sup>	205cm <sup>2</sup>	32in <sup>2</sup>

### 3.6 Extract Fans

If an extract fan is fitted in the premises, there is a possibility that if adequate inlet openings are not provided, spillage of the products from the boiler could occur.

When openings are fitted in accordance with the current issue of BS5440 Part 2 and this section, extract fans should not cause down draught, but where such fan installations are found, a spillage test must be carried out in accordance with the current issue of BS5440 Part 1 and any corrective work done.



## 4 Installation

Before fitting the boiler make sure the location selected is in accordance with the requirements of Section 1.7.

### 4.1 Unpacking

The boiler casing panels are packed separately within the main case. They are designed to enable the gas and water connections to be made before fitting the casing panels.

The main casing brackets, distributor tube and loose items, in a plastic bag, are packed in the top fitment.

### 4.2 Casing Brackets

Fit the four casing brackets as shown in diagram 4.1, using eight No.8 screws.

Push the captive nuts, supplied loose, on to the casing brackets as shown in diagram 4.1.

### 4.3 Water Connections - Gravity Domestic Hot Water and Pumped Heating

Fit suitable fittings into the boiler tappings, see diagram 4.2.

Connect pipework into prepared fittings, making sure that all pipes are taken backwards and will clear the casings, see diagram 1.1.

Heating flow, any one connection of the upper connections may be used.

Gravity domestic hot water flow, any one connection of the remaining upper connections may be used.

Heating return, the distributor tube **MUST** be fitted into either one of the front lower connections on **ALL** installations, see diagram 4.3. The distributor tube is packed in the top carton fitment.

Gravity domestic hot water return, any one connection of the three remaining lower connections may be used.

When the front connections are used it is essential that any pipework or fittings do not stick out more than the amount shown in diagram 4.4.

If limited space only is available, it is recommended that the front connections are used.

Fit plugs into unused tappings.

Do not route any pipes across the front of the boiler thermostat pocket, controls or the combustion chamber cover.

Pipework must not be routed directly below the draught diverter, across the boiler, but may be routed under the edges of the draught diverter.

### 4.4 Water Connections - Fully Pumped Systems

It is important that all connections are made as shown in diagram 4.5.

Fit suitable fittings into the boiler tappings as required, see diagram 4.5.

The water distributor tube **MUST** be fitted into the return connection, see diagram 4.3. The distributor tube is packed in the top fitment.

Connect pipework into prepared fittings making sure that all pipes are taken backwards and will clear the casings, see diagram 1.1.

When the front connections are used it is essential that any pipework or fittings do not stick out more than as shown in diagram 4.4.

If only limited space is available, it is recommended that the front connections are used.

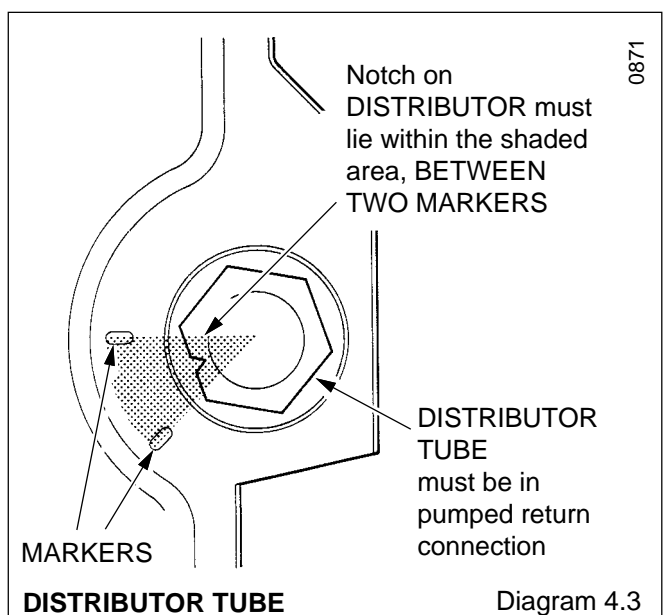
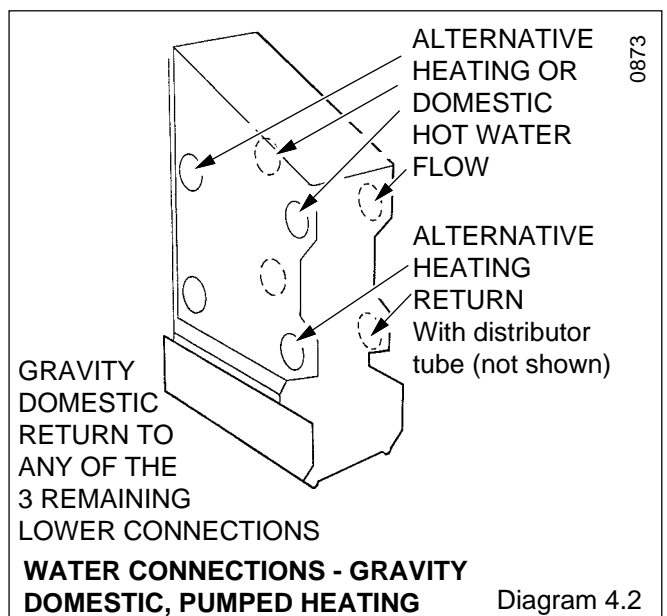
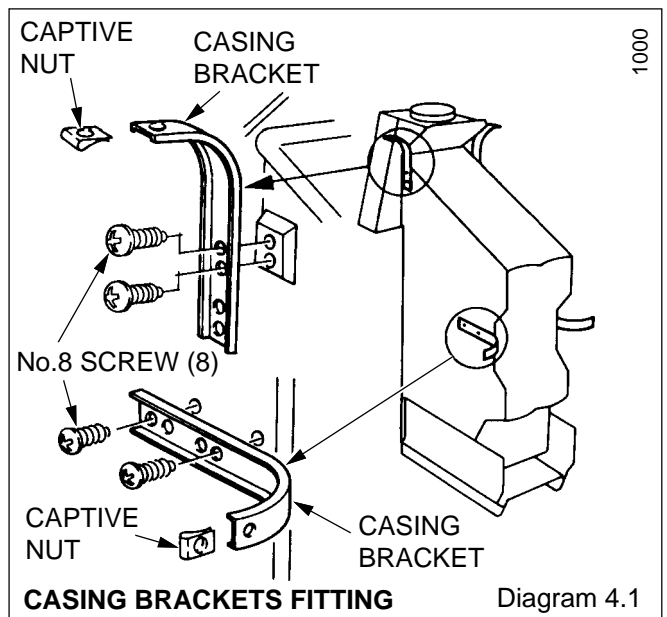

## 4 Installation

Fit plugs into all unused tappings.

Do not route any pipes across the front of the boiler thermostat pocket, controls or combustion chamber cover.

Pipework must not be routed directly below the draught diverter across the boiler, but is allowed to be routed under the edges of the draught diverter.

### 4.5 Pump in Boiler Casing

If the pump is to be fitted inside the boiler casing, position it as shown in diagram 4.6 to either of the front connections.

There must be sufficient clearance "X" between the pump body and the cleaning door to allow for removal of the door for flueway cleaning.

### 4.6 Gas Connection

Do not route the gas supply across the combustion chamber or burner feed pipe. The gas feed must be along the right hand side of the boiler.

Make the gas connection to the gas service cock.

### 4.7 Flue Connection

The flue should be 100mm (4in) nominal diameter, refer to Section 3 and diagram 1.1.

Fix and seal the flue to the hood in accordance with normal practice.

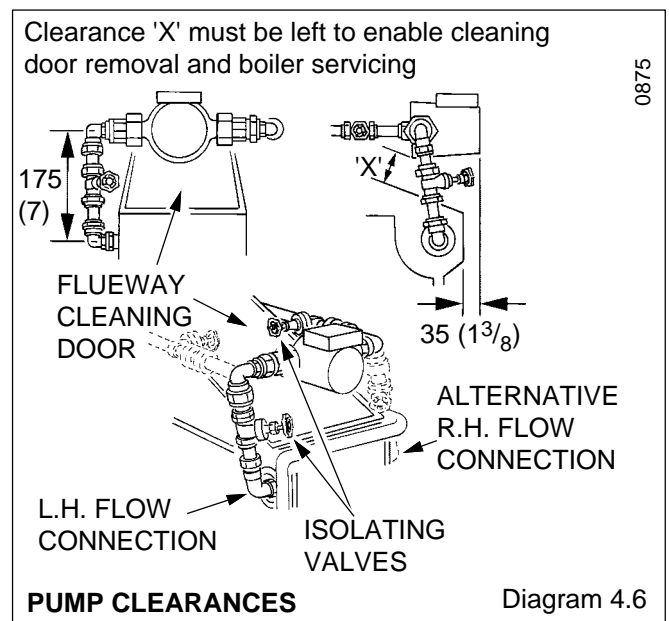
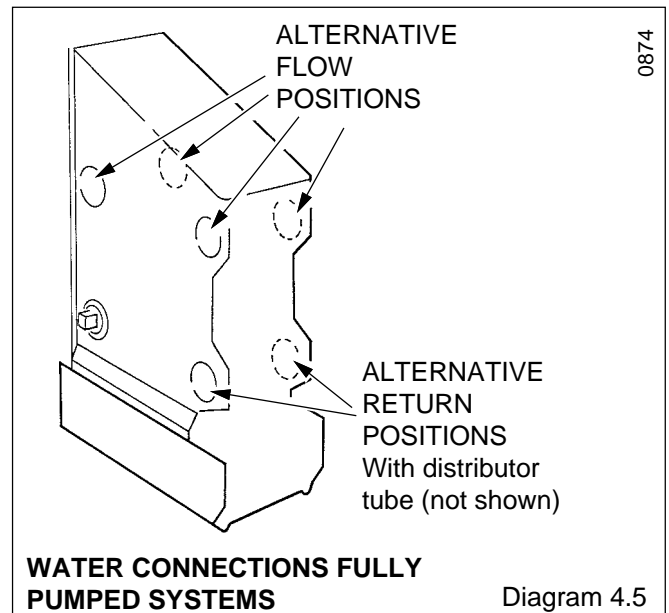
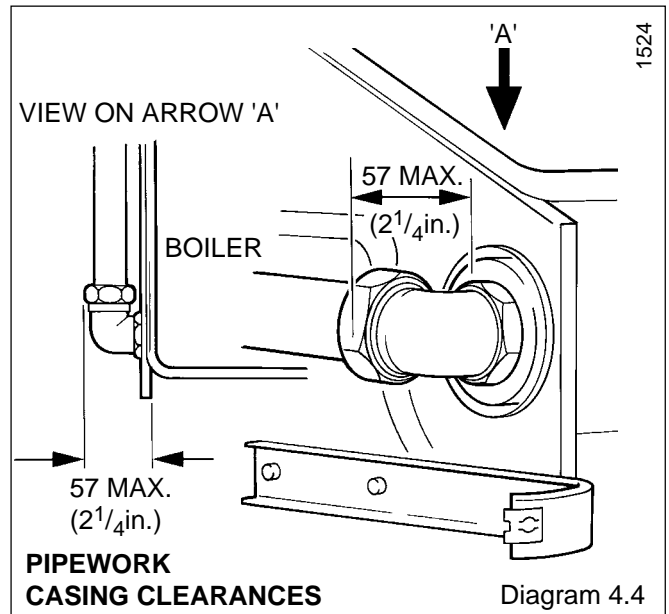

## 5 Casing Location / Fitting

### 5.1 Side Vent Grille

One vent grille is supplied with the boiler which can be fitted at the rear of the left or right hand side casing. The grille is fitted on the opposite side to any pipework connections.

Fit the grille, if required, to the side panel as shown in diagram 5.1 prior to fixing the side panel. The plastic pegs are a tight fit and are best pushed home with a flat faced tool.

Do not use the grille if water connections are on both sides of the boiler or if the boiler is screened by fixtures.

### 5.2 Side Casings

Fit side casing by locating their lugs into the lower slots in the base tray, see diagram 5.2.

Secure the casing sides to the casing bracket at the front top.

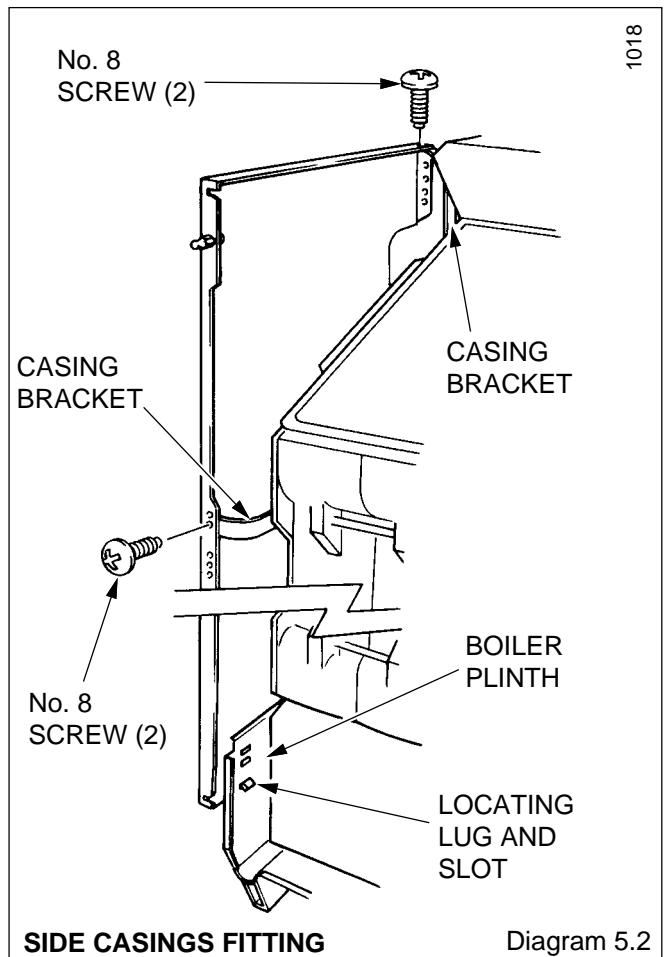
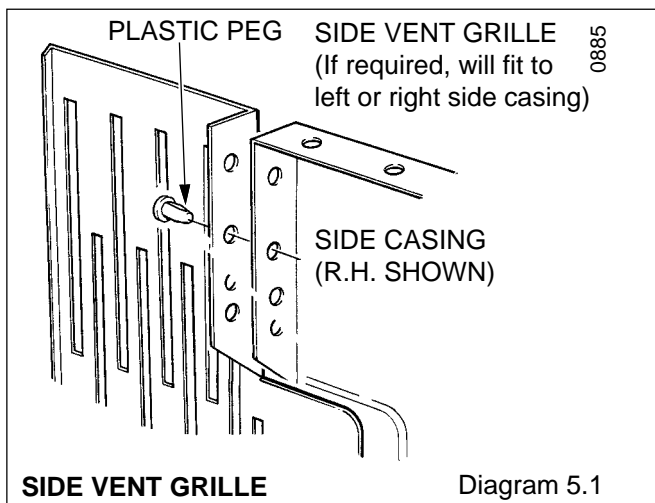

## 6 Electrical Wiring

### 6.1 Control Box Cable Connection

Remove the screw and cover from the mains inlet connector, see diagram 6.1.

Using heat resistant flexible cable of suitable length and rating, as Section 1.6, connect the cable to the terminals in the connector. Secure the outer sheathing with the clamp.

Engage slots and lugs, replace connector cover and secure with screw.

Connect mains inlet connector to the control box and use three of the cable clips, supplied loose, pushed on to the edge of the left hand panel in positions "CB" as shown in diagram 6.2 to make sure that the cable does not touch any hot surfaces.

### 6.2 Circulation Pump Cable Connection

Heat resistant cable with a rating as stated in Section 1.6 must be used for all wiring near the boiler, including the pump, if within the boiler casing.

Support the pump cable away from hot surfaces if within the boiler casing by pushing two cable clips, supplied loose, on to the top edge of one side casing, as shown as "P" or "AP" in diagram 6.2.

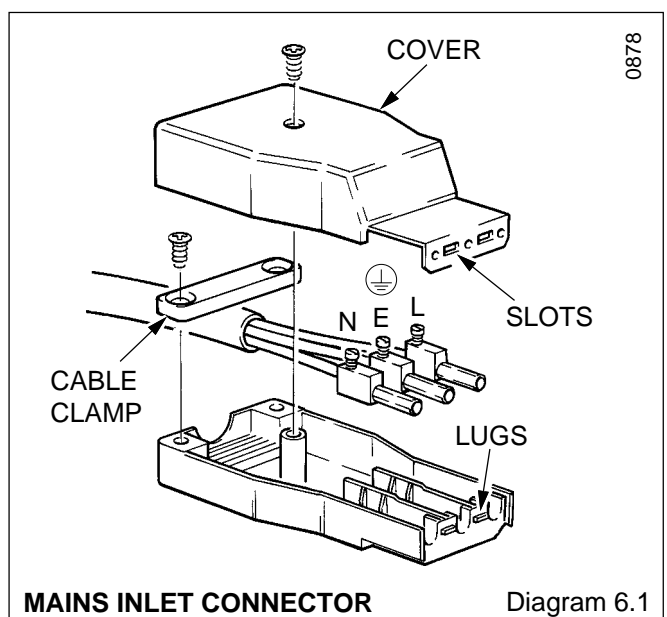

## 6 Electrical Wiring

### 6.3 Flue Blockage Safety Device - Capillary and Interrupter Electrical Leads

For transit the capillary is taped to the side of the boiler.

Remove tape and place capillary into cable clips provided, see diagram 6.2.

Note: Capillary must not touch the heat exchanger side.

Secure the interrupter electrical leads so as not to strain them, see diagram 6.2.

### 6.4 System Controls

The electrical installation must be in accordance with the current issue of BS7671.

The electrical isolator must isolate both the boiler and system controls.

### 6.5 Testing

Checks to ensure electrical safety should be carried out by a competent person.

In the event of an electrical fault after installation of the boiler, preliminary system checks must be carried out, that is, earth continuity, polarity and resistance to earth as described in a multimeter instruction book.

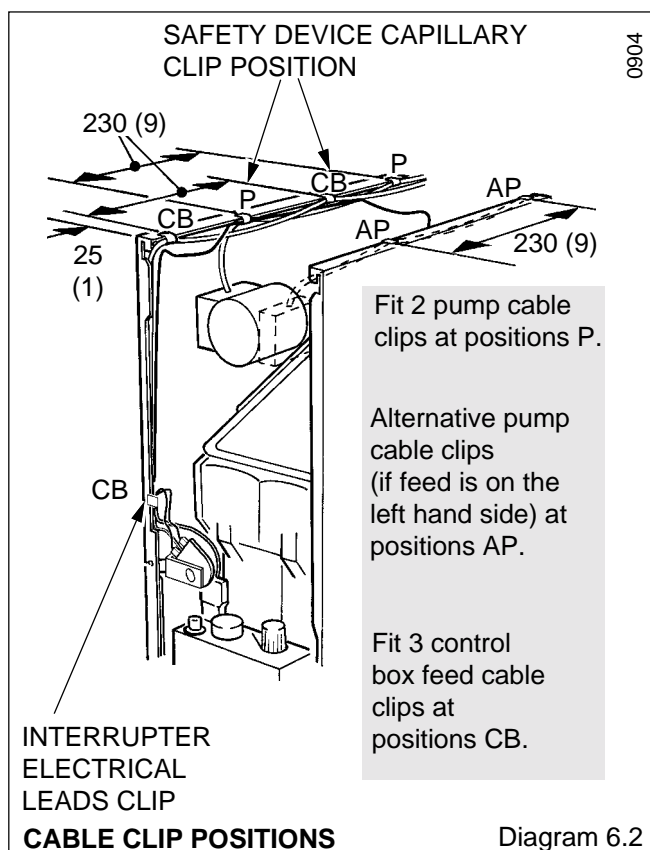

Diagram 6.2

## 7 Commissioning

Please ensure the "Benchmark" logbook is completed and left with the user.

### 7.1 Commissioning and Testing the Boiler

The whole of the system should be thoroughly flushed out with cold water with pump removed. Make sure that all valves are open. Refit the pump and fill the system. Examine for water soundness and vent all air from the system, including the pump.

Caution. The following should be done by a competent person.

Identify the controls, refer to diagram 7.1.

Check that the gas cock "K" is closed, that is, slot is horizontal.

Open all windows and put out any naked lights, pipes or cigarettes.

Purge air from the gas supply in accordance with the current issue of BS6891.

Carefully unwind the thermostat capillary, insert the phial fully into pocket "J" and secure the location washer behind the retaining split pin, supplied in the loose items pack, see diagram 7.2.

Check that the mains electrical supply is switched off.

Set thermostat control knob "B" to "O".

Remove gas test pressure point screw "G" and fit a suitable pressure gauge.

Open gas cock "K", slot vertical.

Note: Make sure the Flue Blockage Safety Device reset button 'N' is fully pushed in.

Turn gas control knob "A" to '★', the pilot and ignition position and push in. At the same time press and release the ignition button "C" until the pilot lights. At this stage air may be present

in the gas supply pipes and this operation may need to be repeated. When the pilot burner lights, keep control knob "A" fully pushed in for about 15 seconds. If the pilot fails to remain alight, repeat lighting procedure, but now keep the control button pushed in for a little longer.

If the control knob "A" is turned to '●', a safety device prevents relighting in an unsafe condition. No attempt should be made to push knob "A" in until 3 minutes have gone by.

Note: Should the boiler fail to operate correctly refer to the Fault Finding - Section 10.

Make sure that the pilot is alight and stable, see diagram 7.3 for flame length, switch on the electrical supply. Set any remote controls so that they are calling for heat. Turn control knob "A" to '⌋' main burner position. Set boiler thermostat control knob "B" between "MIN" and "MAX" against the setting point on the control box, the main burner will light. "MAX" is about 82°C (180°F).

Test for gas soundness around boiler gas components with a suitable leak detection fluid.

Set the burner gas pressure required, ten minutes after lighting, see Data label "L" for settings or refer to Section 1.2. Adjust screw "F", diagram 7.1 to obtain the required heat input. Turn clockwise to decrease. After adjusting, seal the screw.

If any doubt exists, the gas rate should also be checked at the meter. This should be in the range of:

**Hideaway - 60** - 2.2 to 2.5m<sup>3</sup>/h 63 to 71.2ft<sup>3</sup>/h

The rates are for guidance only, depending on the heat setting.

Stick the self adhesive arrow on to the data label against the output the boiler is set to. The arrow is in the loose items pack.

Check the operation of the flame failure device as follows:

With the main burner alight, turn the gas control valve knob "A"

## 7 Commissioning

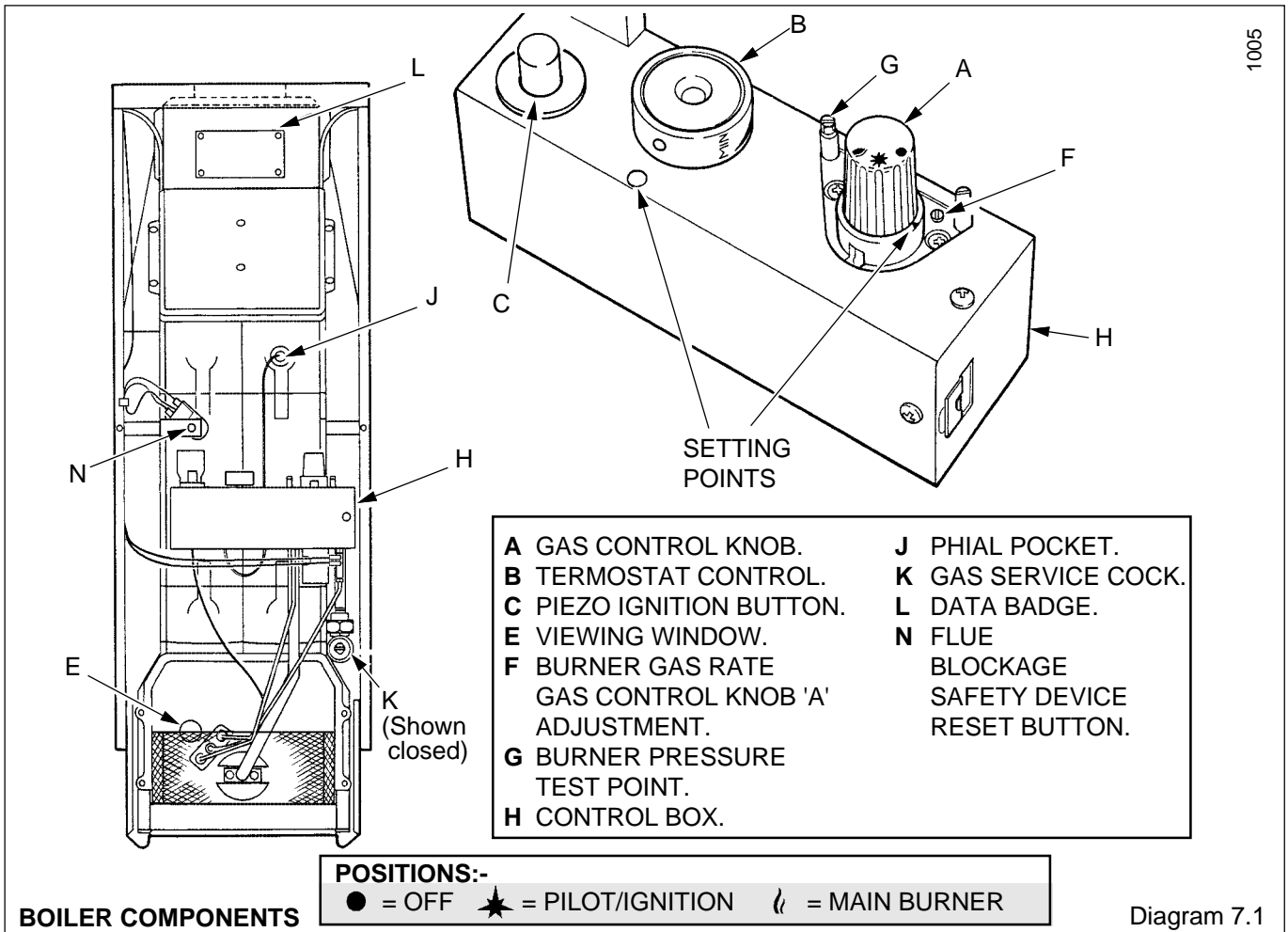

fully clockwise to its stop '●', the main and pilot flames will go out. Relighting will not now be possible. Before 60 seconds the safety device will work, indicated by a "click" from the gas valve.

Do not attempt to relight until three minutes have gone by.

Remove the pressure gauge and refit the pressure test point screw "G", makes sure a gas tight seal is made.

Turn thermostat "B" to "O" and relight the pilot burner as above.

Relight the main burner as above.

Check that the boiler thermostat and all remote controls are working correctly.

Do not attempt to adjust the thermostat calibration screw.

Test the boiler for spillage of the flue products at the draught diverter as detailed in the current issue of BS5440 Part 1. If an extract fan is fitted in the premises, refer to Section 3.6.

### 7.2 Commissioning the System

Allow the system to warm up and set the pump adjuster to a design position which gives the correct temperature difference of 11°C (20°F) between the flow and return. There should be no undue noise in the system, pumping over or entry of air at the open vent above the cold water feed and expansion cistern.

Allow the system to reach maximum working temperature and examine for water soundness.

The system should then be drained down as rapidly as possible to complete the flushing process.

The system should then be refilled, vented and examined for water soundness.

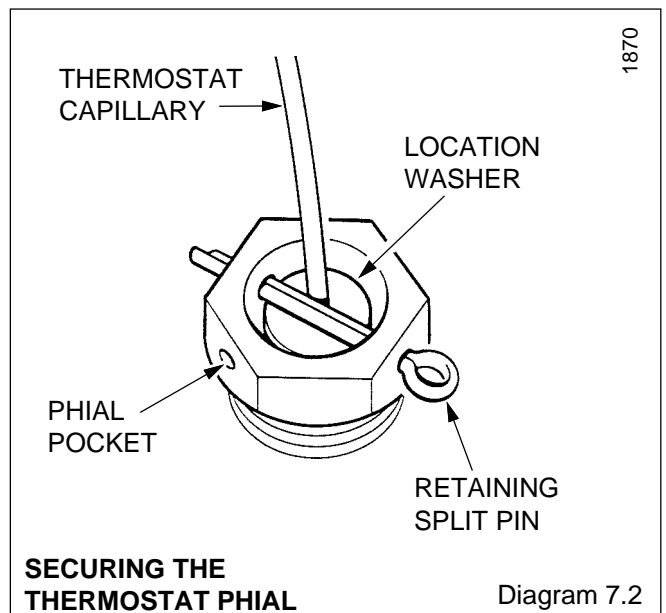



## 7 Commissioning

### 7.3 Completion

Instruct and demonstrate the efficient and safer operation of the boiler, heating and domestic hot water system.

Hand the Instructions for Use to the user, for them to keep, making sure that they fully understand them.

Advise the user that to ensure the continued efficient and safe operation of the boiler is recommended that it is checked and serviced at regular intervals. The frequency of servicing will depend upon the particular installation and usage, but in general once a year should be enough.

Draw attention, if applicable, to the current issue of the Gas Safety (Installation and Use) Regulations, Section 35, which imposes a duty of care on all persons who let out any property containing a gas appliance.

It is the law that servicing is carried out by a competent person.

Advise that the boiler is fitted with a Flue Blockage Safety Device and refer to the Instructions for Use.

Reminder - Leave these instructions and the "Benchmark" logbook with the user.

Fit the plinth front, by locating the sides over the boiler plinth then lowering to engage the upper and lower hooks, see diagram 7.4.

Fit four plastic pegs into the required holes in the top panel, see diagram 7.5. The plastic pegs are a tight fit and are best pushed home with a flat faced tool.

Push the casing top on to all four side panel locations. From inside the casing check that all the rivets have engaged into the holes.

Fit the door by locating the hooked runner at the bottom into the slots in side casings and pushing on to the studs on the side casings, see diagram 7.4.

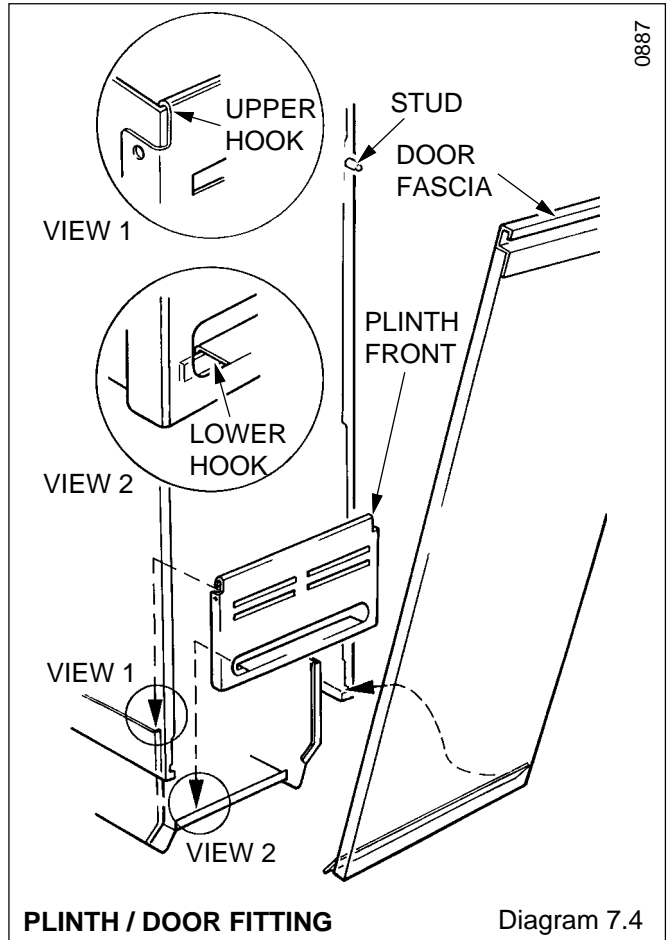

0887

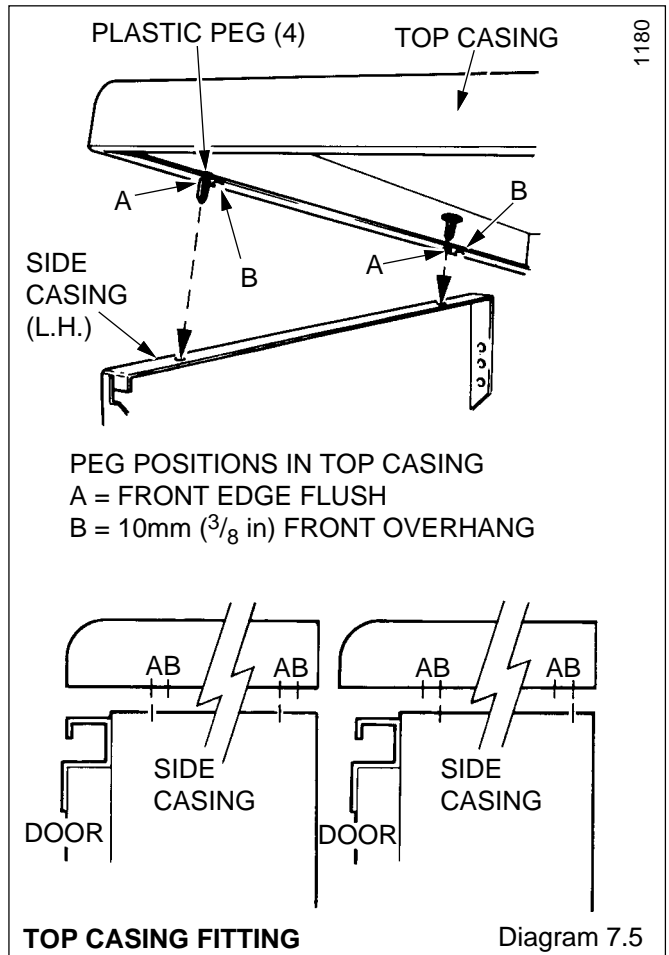

1180

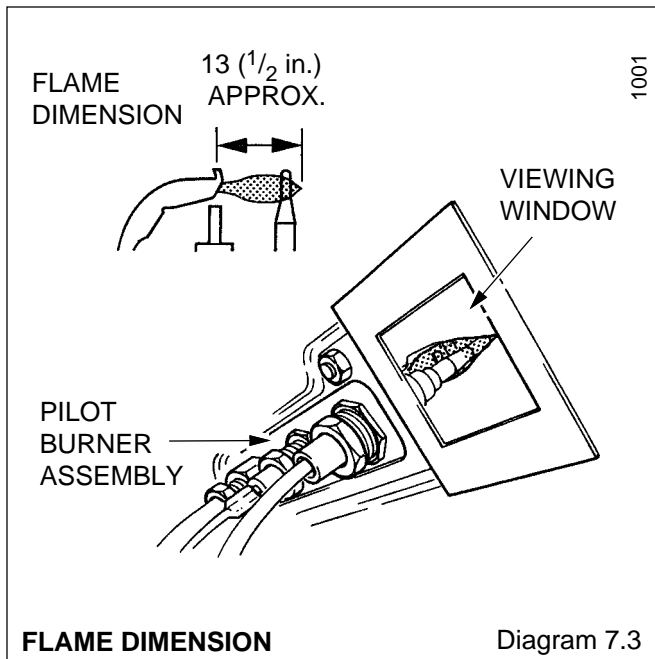

1001



## 8 Servicing

Servicing must be carried out by a competent person.

Before servicing, turn off the gas supply at the boiler service cock, see diagram 8.1 and isolate the electrical supply to the boiler.

Always test for gas soundness after completing a service and replacement of parts.

### 8.1 Boiler Flueways

Pull door forwards at the top to disengage the studs and lift to release from slots, see diagram 7.4.

Lift plinth front up and forwards to withdraw, see diagram 7.4.

Disconnect the union on the gas service cock, see diagram 8.1.

Remove the mains inlet connector by pulling upwards, see diagram 8.1.

Withdraw the retaining split pin from the thermostat phial pocket then withdraw the phial and capillary, see diagram 8.2.

Remove electrical connections from the interrupter, see diagram 8.1.

Remove the four screws retaining the combustion chamber cover and burner assembly, see diagram 8.3. Withdraw forwards the complete assembly of cover, control box and burner.

Remove the graphite coated nut to release baffle tray and remove the combustion chamber, taking care not to damage the insulation material on the sides.

Remove the self-tapping screws which retain the cleaning door and lift clear, see diagram 8.4.

Place a sheet of paper in the combustion chamber to catch any flue debris.

Remove flueway baffles, see diagrams 8.7 and 8.8.

Thoroughly clean boiler flueways and fins with a suitable stiff brush.

Replace in reverse order, after completing instructions in Section 8.2 and 8.3.

Make sure that the thermocouple phial is at the bottom of its pocket and located by the washer being behind the retaining split pin, leaving clearance between the capillary tube and boiler, see diagram 8.2.

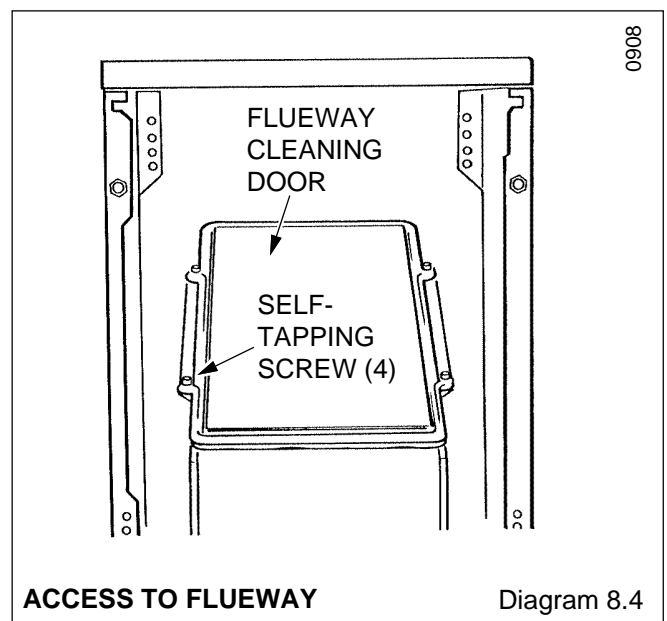
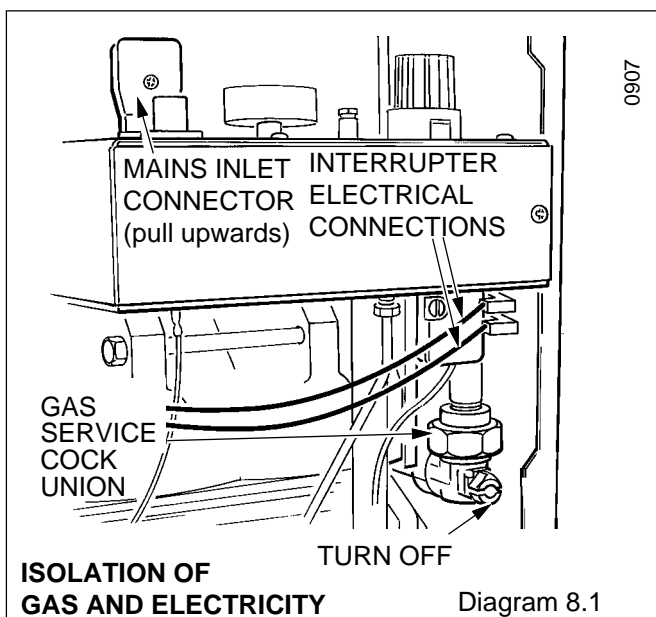
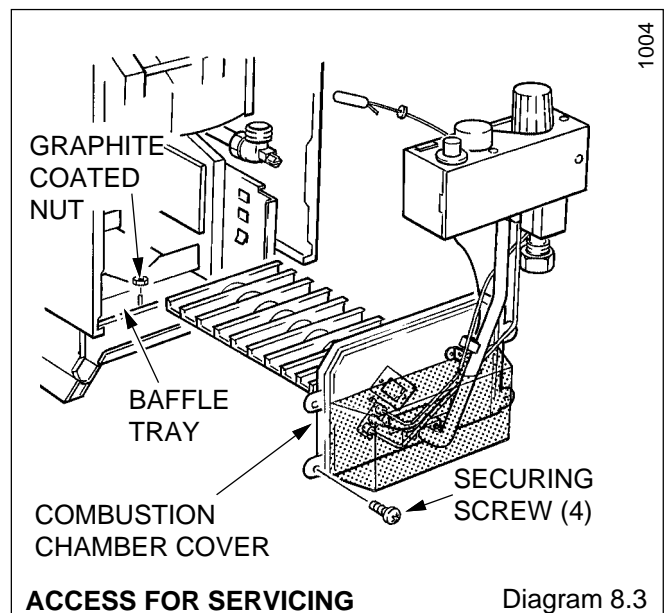
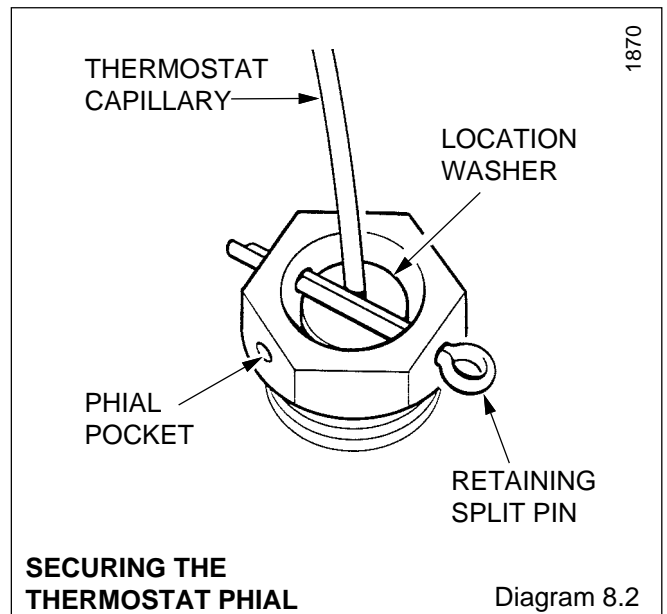

## 8 Servicing

### 8.2 Burner and Injector

Follow instructions to remove the front cover, burner and controls assembly as Section 8.1.

Remove the screw securing the lint arrester gauze to the combustion chamber cover. Remove arrester by lifting slightly and withdrawing forwards to clear gas pipe, thermocouple and pilot tube, see diagram 8.5.

Remove the two burner securing nuts from the flange of the burner supply pipe.

Remove the burner from the cover and supply pipe flange.

Remove the securing nut, washer and burner end cap from the burner, see diagram 8.6.

Clean the burner parts and lint arrester thoroughly, using a vacuum cleaner.

Check the main burner injector for blockage or damage and replace as necessary, see Section 9.2.

When replacing lint arrester locate the two lugs into the slots on the combustion chamber cover and locate around the feed pipe, then secure with the screw.

### 8.3 Service Checks

Inspect the pilot burner, thermocouple and pilot burner, cleaning as necessary. Check the condition of the parts. If necessary remove the pilot shield by removing the securing screw and nut.

Check the condition of the side and rear insulation panels in the combustion chamber.

Check the condition of the seals on the cleaning door and the combustion chamber cover.

Replace all items in the reverse order, relight and test the boiler.

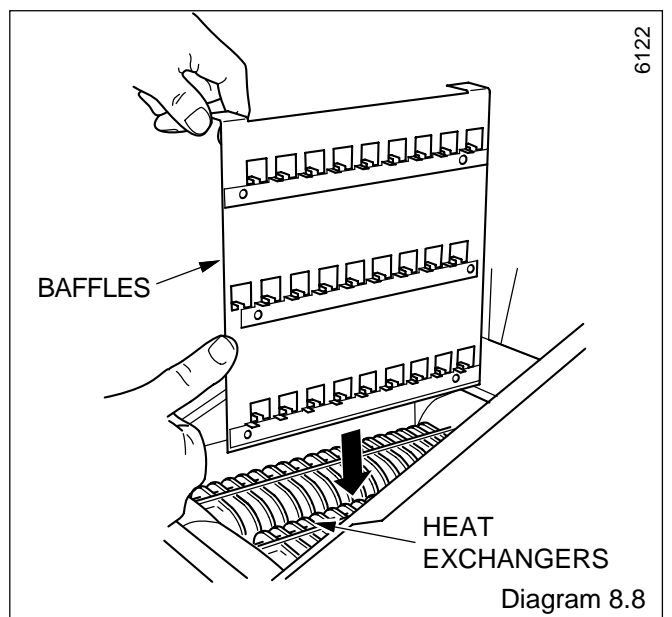
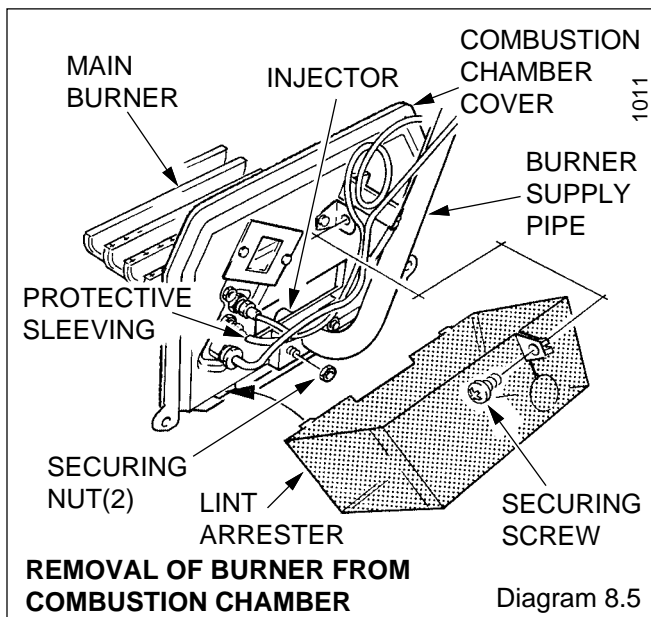
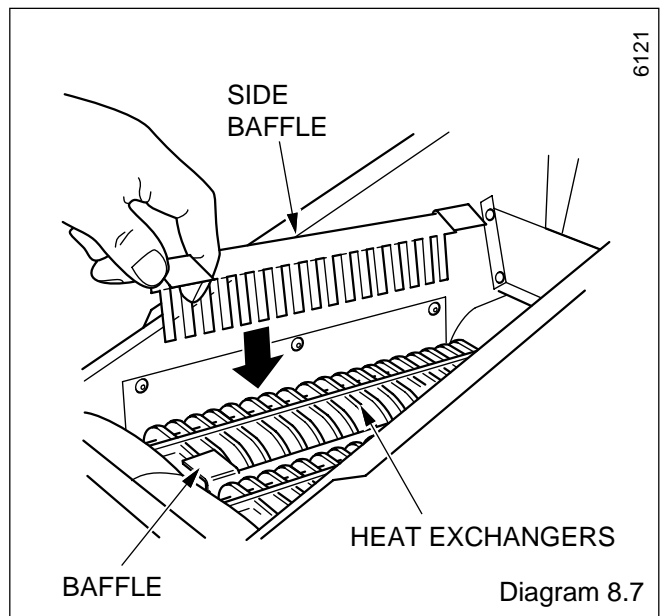
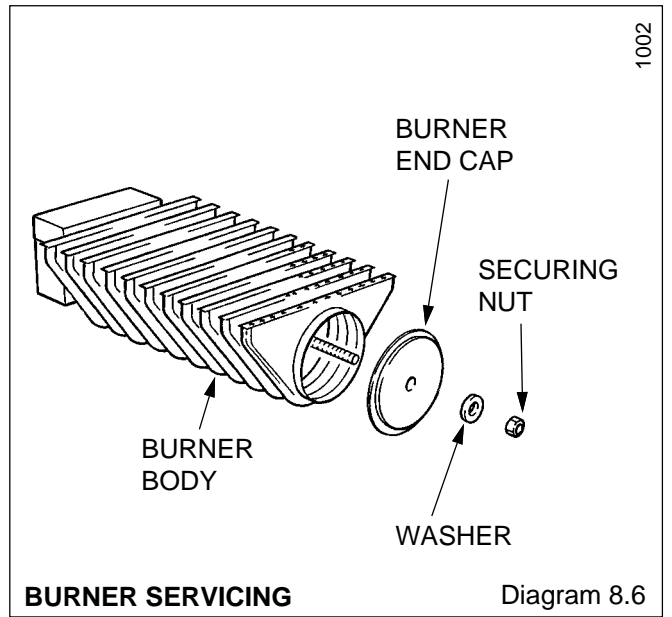

## 9 Replacement of Parts

6123

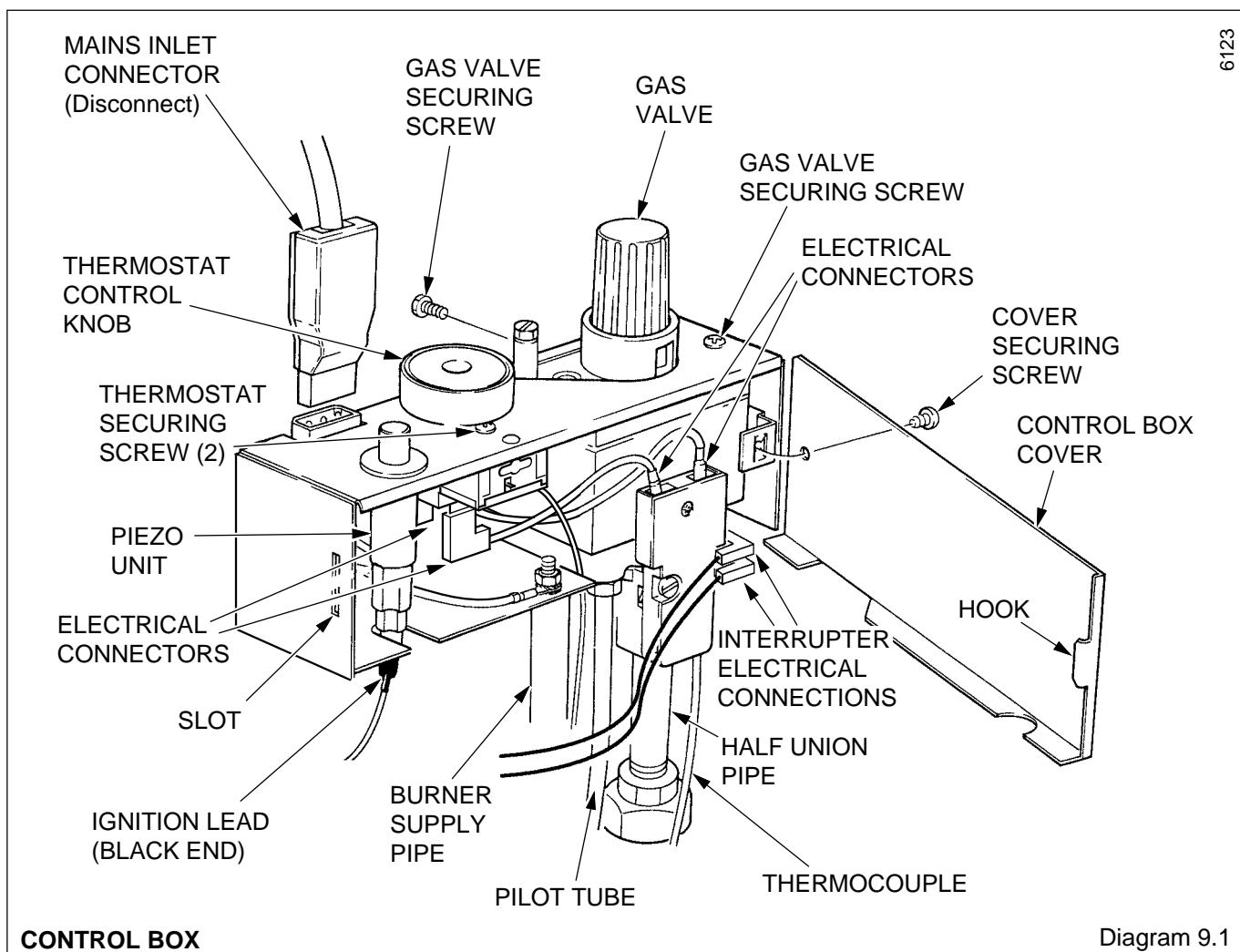

Diagram 9.1

Replacement of parts should be carried out by a competent person.

Before removing or replacing any parts, turn off the gas supply at the boiler service cock, see diagram 8.1. Isolate the electrical supply to the boiler.

Unless stated otherwise all parts are replaced in the reverse order to removal.

Always test for gas soundness after replacing parts.

### 9.1 Gas Valve

Follow the relevant instructions in Section 8.1.

Remove control box cover by removing the screw and unhooking at the side, see diagram 9.1.

Disconnect thermocouple nut, interrupter, electrical connections and pilot tube connection at the gas valve.

Remove the two screws which secure gas valve to the control box.

Tilt control box to enable it to be lifted off the gas valve.

Unscrew half union pipe from gas valve.

Unscrew the gas valve from the burner supply pipe.

When screwing the pipes into the new gas valve use a little jointing compound on the external thread only, to make a gas tight seal.

Replace thermostat phial as relevant part of Section 8.1.

Refer to diagram 9.2 to connect electrical leads.

It will be necessary to purge the system of air after changing the gas valve. Follow the instructions in Section 7.1.

### 9.2 Boiler Thermostat

Follow the relevant instructions in Section 8.1 and 9.1.

Pull off the thermostat control knob.

Remove the two screws which secure the boiler thermostat to the control box, see diagram 9.1.

Tilt the thermostat so that the electrical connections can be removed.

Withdraw boiler thermostat from control box complete with capillary tube and phial.

Refer to diagram 9.2 to connect electrical connectors.

Replace the thermostat phial as the relevant part of Section 8.1.

### 9.3 Piezo Unit

Pull door forward at the top to disengage the studs and lift to release from slots, see diagram 7.4.

Remove mains inlet connector by pulling upward, see diagram 8.1.

Remove the control box cover by removing screw and unhooking from slot at the side, see diagram 9.1.

Disconnect the ignition lead at the piezo unit.

Remove the nut inside the control box and remove piezo unit.

## 9 Replacement of Parts

240V~ 50Hz MAINS SUPPLY FUSED AT 3A

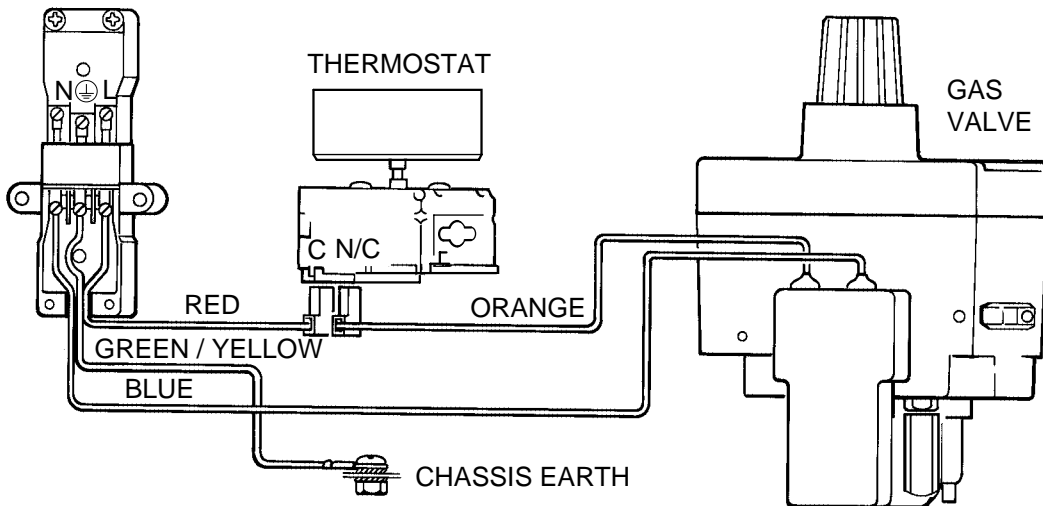

**CONTROL BOX WIRING**

Diagram 9.2

6124

### 9.4 Thermocouple

Remove the door and plinth from the front as relevant parts of Section 8.1.

Remove lint arrester as in Section 8.2.

Disconnect the thermocouple by unscrewing nuts at the gas valve and pilot burner, see diagram 9.1 and 9.3. Release cable clips and the thermocouple can be withdrawn.

Do not tighten nut at gas valve more than a quarter turn beyond finger tight.

Replace lint arrester as Section 8.2.

### 9.5 Spark Electrode

Remove the door plinth as the relevant part of Section 8.2.

Remove the lint arrester as Section 8.2.

Disconnect the ignition lead, see diagram 9.3.

Disconnect the thermocouple nut and withdraw the thermocouple from the pilot burner.

Disconnect the nut retaining the spark electrode.

The spark gap dimension is shown on diagram 9.4.

### 9.6 Ignition Lead

Remove the door and plinth as the relevant parts of Section 8.1.

Remove the lint arrester as in Section 8.2.

Disconnect the ignition lead at the piezo unit, see diagram 9.1.

Disconnect ignition lead at the spark electrode, see diagram 9.3.

When reconnecting the lead, make sure that the clear end is fitted to the spark electrode and the protective sleeve is fitted where the lead passes through the lint arrester, see diagram 8.5.

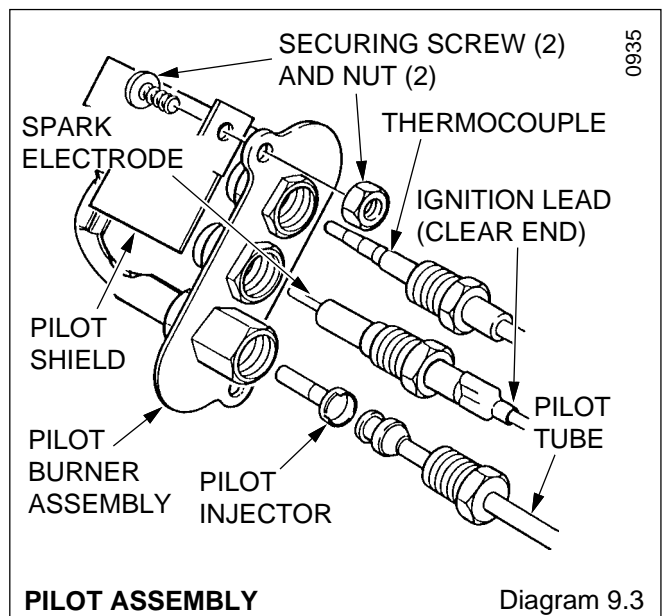

**PILOT ASSEMBLY**

Diagram 9.3

0935

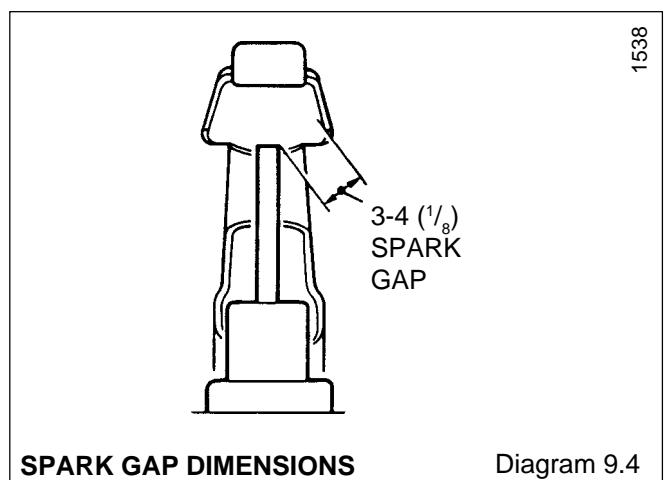

**SPARK GAP DIMENSIONS**

Diagram 9.4

1538

## 9 Replacement of Parts

### 9.7 Pilot Burner

Follow the instructions in the relevant parts of Section 8.1 to remove cover and burner controls assembly.

Remove the lint arrester as in Section 8.2.

Disconnect the thermocouple nut at the pilot burner, see diagram 9.3.

Disconnect the nut retaining the pilot tube and injector in the pilot burner.

Remove the two screws and nuts securing the pilot burner and the shield front cover, see diagram 9.3.

Check that the pilot flame length is as shown in diagram 7.3.

Replace thermostat phial as Section 8.1.

Replace lint arrester as Section 8.2.

### 9.8 Insulation Panels

Follow the relevant instructions in Section 8.1.

Unfasten the two screws retaining each side insulation panel within the combustion chamber and remove panel, see diagram 9.5.

Release the rear insulation panel upper clips and lift out panel.

Replace thermostat phial as Section 8.1.

### 9.9 Injector

When the burner has been removed from the injector manifold as in Section 8.2 the injector can be unscrewed from the manifold and renewed as necessary.

When replacing use a little jointing compound on the external threads only, to make a gas tight seal.

Replace thermostat phial as Section 8.1.

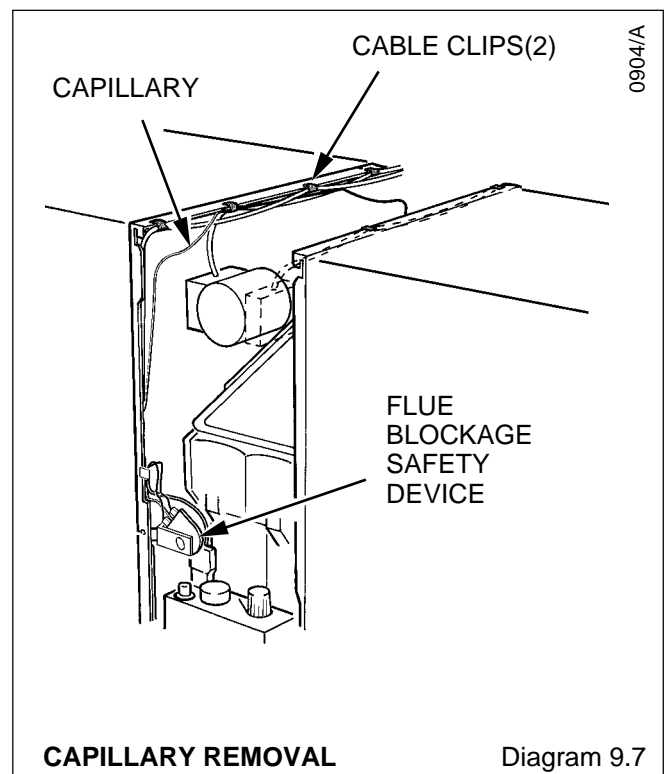
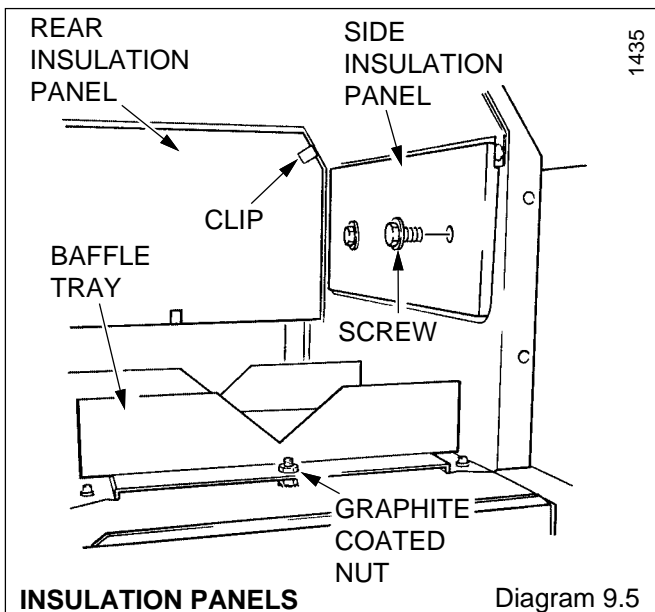
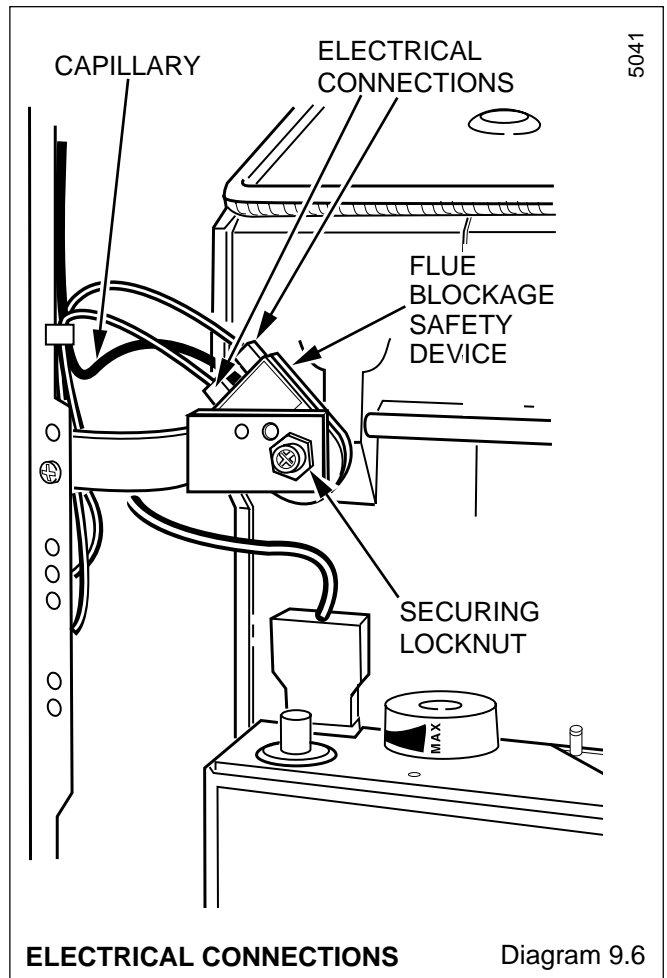

## 9 Replacement of Parts

### 9.10 Flue Blockage Safety Device

Gain access as Section 8.1.

Remove the electrical connections, see diagram 9.6

Remove capillary from cable clips, see diagram 9.7.

To remove the phial assembly, first gain access through flue cleaning door as Section 8.1.

Unscrew securing nut and withdraw the phial assembly from the location stud, see diagram 9.8.

Remove the safety device securing locknut complete with phial assembly, see diagram 9.6.

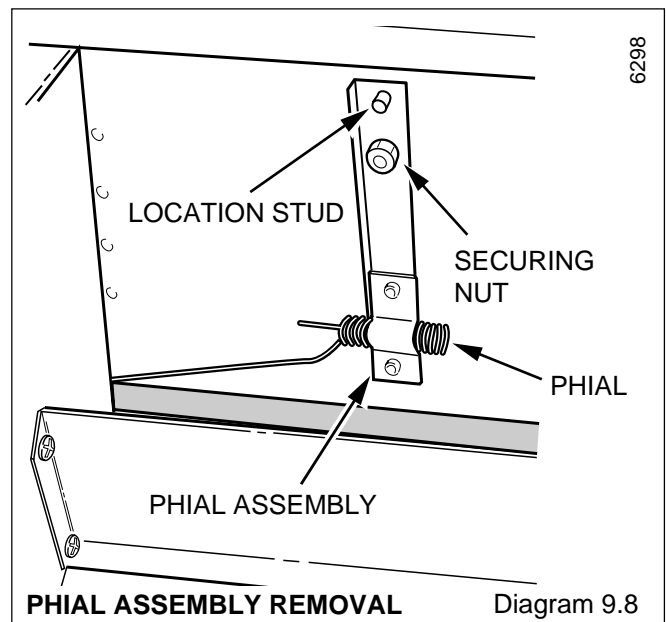

## 10 Fault Finding - Electrical

### 10.1 Electrical

Refer to functional flow diagram 10.1, electrical fault finding chart, diagram 10.2 and wiring diagram 9.2.

**IMPORTANT.** The preliminary electrical system checks contained in a multimeter instruction book are the first checks to be carried out during and fault finding procedure. On completion of the service fault finding task which has required the breaking and remaking of electrical connections then checks. earth continuity, polarity and resistance to earth must be repeated.

### 10.2 Thermocouple

To test the thermocouple a meter with a range 0 to 30mV is required together with a thermocouple interrupter test unit similar to the British Gas Multimeter and interrupter.

Refer to thermocouple fault finding chart, diagram 10.3 and diagnosis graph, diagram 10.4.

### 10.3 Pilot and Ignition

Refer to pilot and ignition fault finding chart, see diagram 10.6 and 10.3.

### 10.4 Flue Blockage Safety Device

If the device operates it indicates there is a problem with the chimney. Make sure that the air vents are free from obstruction. Carry out spillage checks as BS5440 Part 1 and put right as necessary.

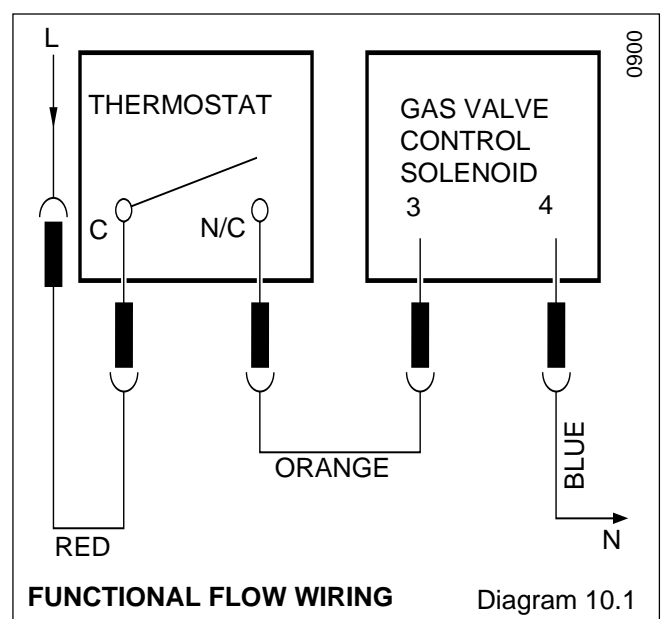



## 10 Fault Finding - Electrical

0899/A

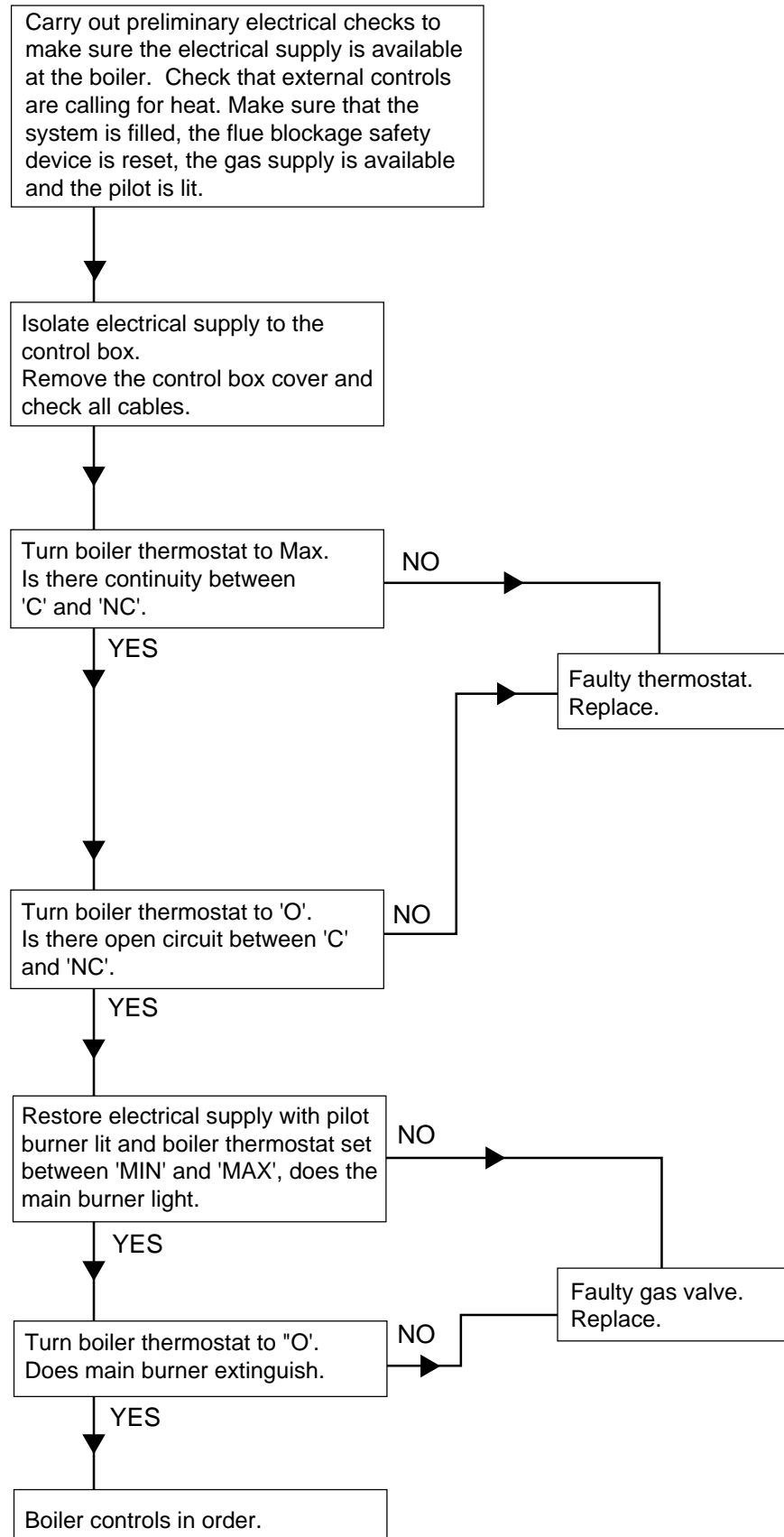

# 10 Fault Finding - Thermocouple

2327/B

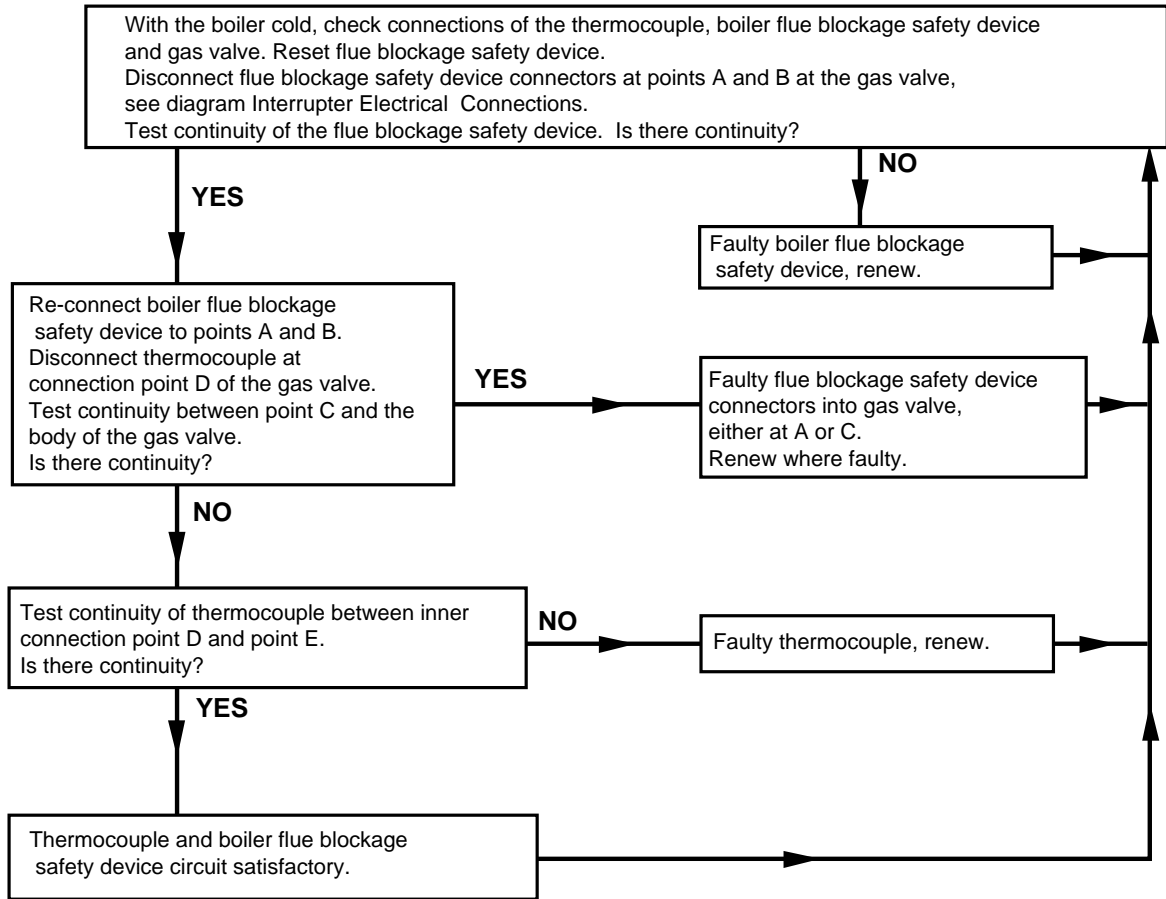

**THERMOCOUPLE AND FLUE BLOCKAGE SAFETY DEVICE FAULT FINDING**

Diagram 10.3

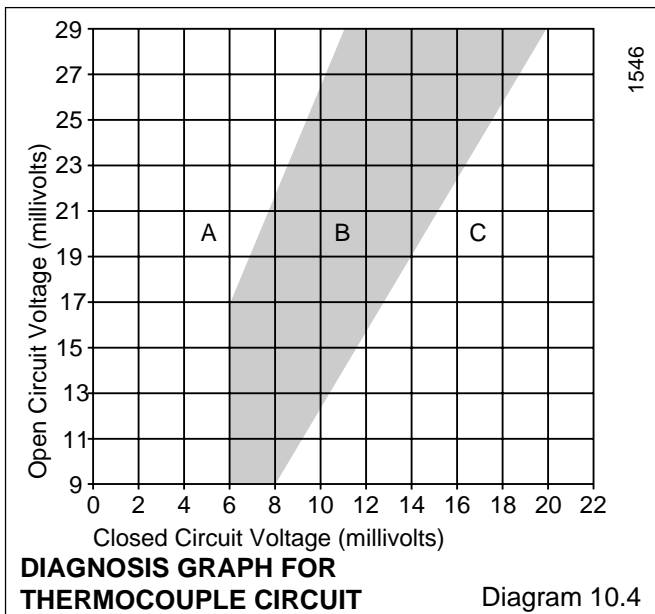

1546

**DIAGNOSIS GRAPH FOR THERMOCOUPLE CIRCUIT**

Diagram 10.4

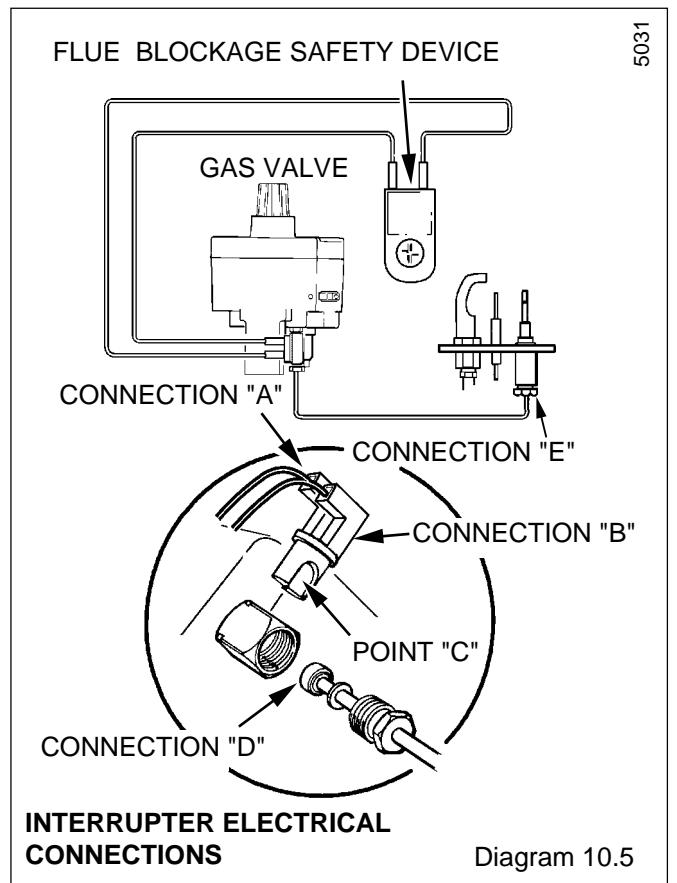

5031

**INTERRUPTER ELECTRICAL CONNECTIONS**

Diagram 10.5

# 10 Fault Finding - Pilot

0905A

## START HERE

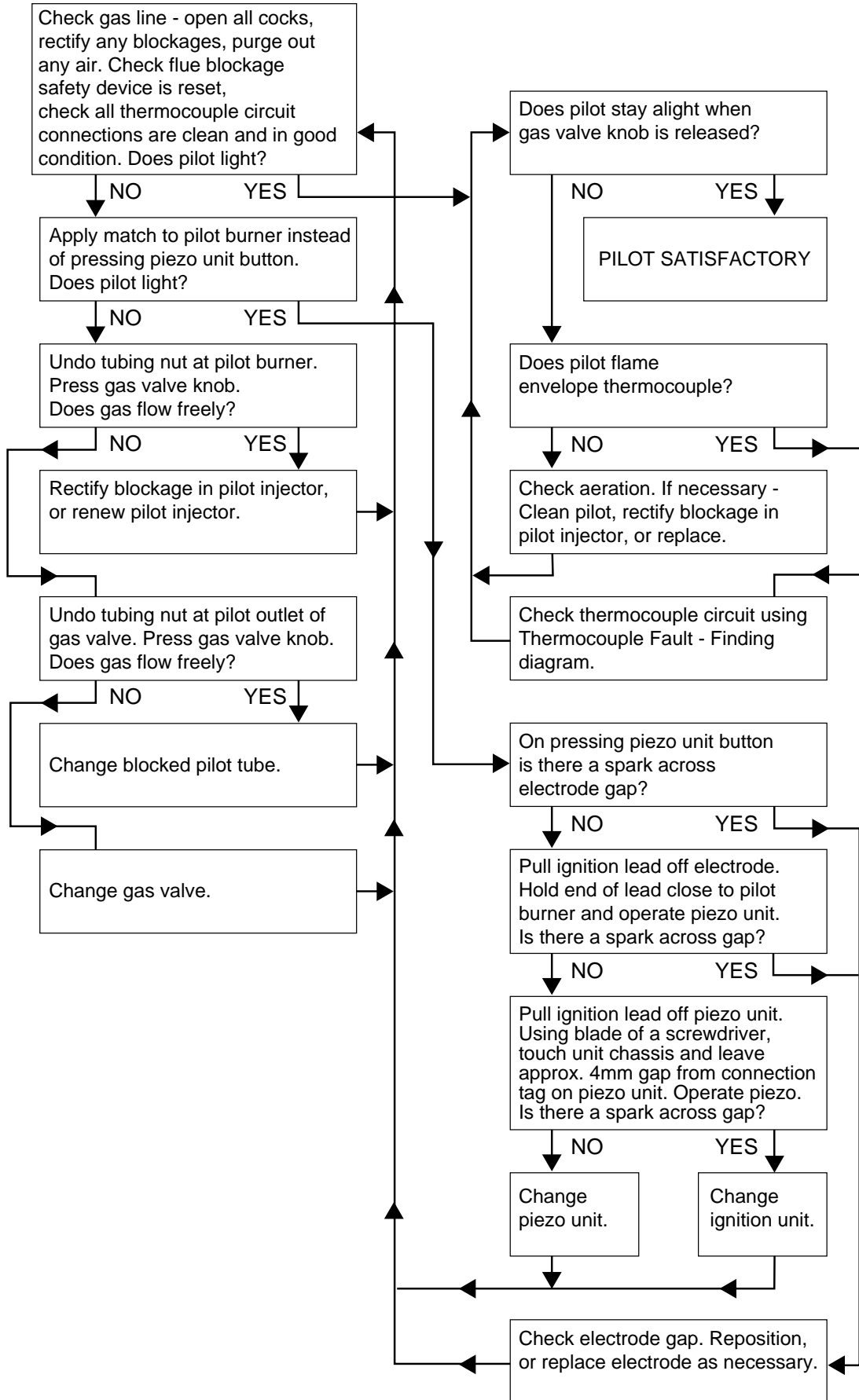

## 11 Spare Parts

### 11.1 Part Identification

The key number in the first column of the list will help identify each part shown in diagram 11.1.

### 11.2 Ordering

When ordering spare parts quote the part number and description, stating the model and serial number off the data label "L", see diagram 7.1.

If ordering from British Gas also quote the GC appliance number off the data label and the required spare part GC number.

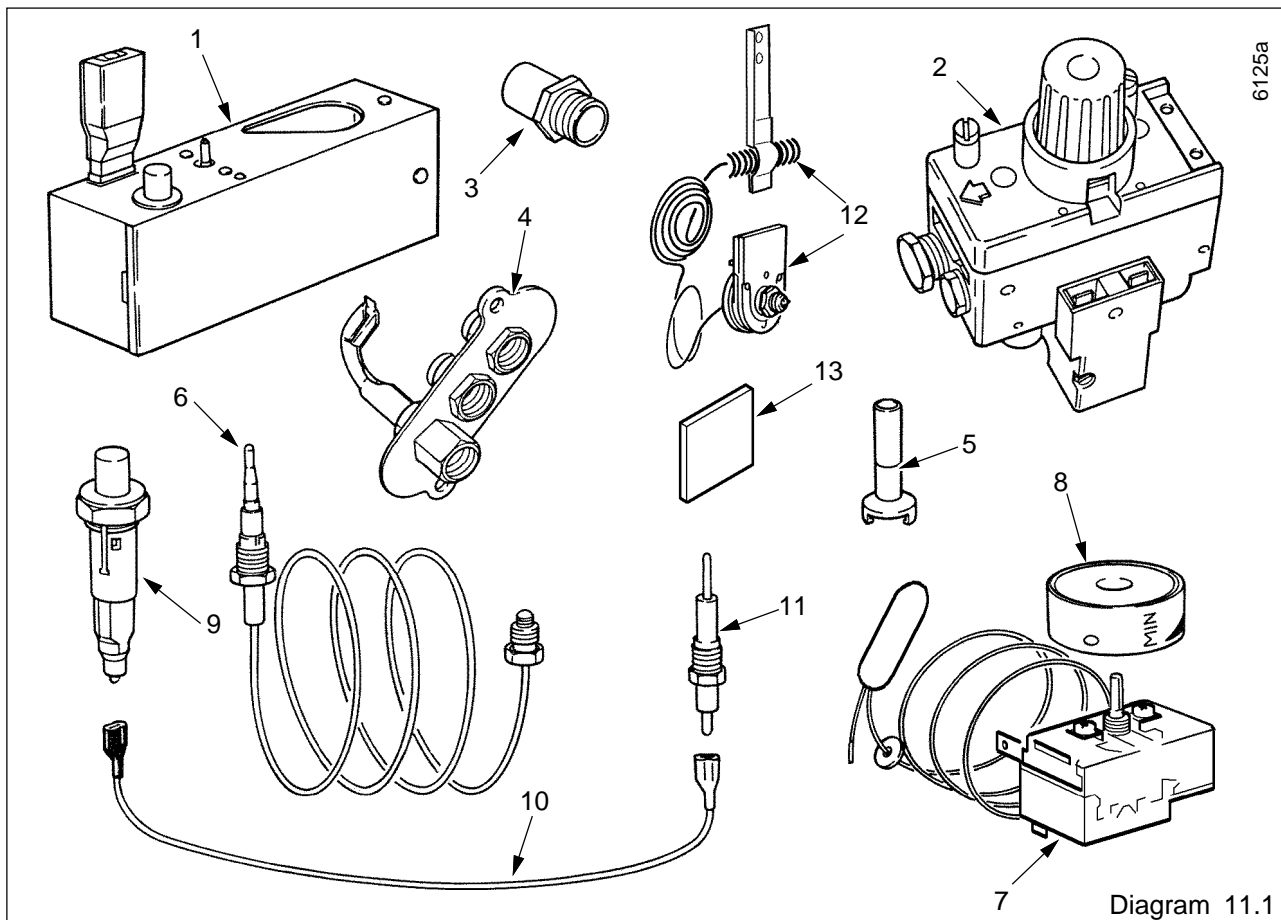

Diagram 11.1

Key No	Part No	Description	GC Part No
1	425568	Electrical control box assy	312 451
2	203329	Gas control valve	384 345
3	205751	Injector - 60	
4	203414	Pilot burner assy	312 246
5	203508	Injector - pilot	395 674
6	900001	Thermocouple c/w nut	
7	202571	Thermostat c/w screws	
8	FF2228	Control knob assy	355 241
9	900501	Piezo unit	382 585
10	WW4613	Ignition lead	136 399
11	202605	Spark Electrode	395 720
12	425795	Flue Blockage Safety device	E02717
13	208302	Sight Glass	312 419

*Because of our constant endeavour for improvement, details may vary slightly from those shown in these instructions.*