



# SYS 10-23

**Wall-Hung, Gas-Fired,  
System Boiler,  
for Central Heating**



**INSTALLATION,  
MAINTENANCE AND USER  
INSTRUCTIONS**



## IMPORTANT

Your "benchmark" Installation, Commissioning and Service Record Log Book will be enclosed in your customer information pack. "This record must be completed and left with the end user"

"All CORGI Registered Installers carry a CORGI ID card and have a registration number. Both should be recorded in your central heating log book. You can check with the CORGI registered by calling CORGI on 01256 372300".



- Carefully read the warnings in this instruction booklet, as they provide important indications on the safety of installation, operation and maintenance.
- The instruction booklet is an integral and essential part of the product and must be carefully kept by the user for future reference.
- If the appliance is sold or transferred to another owner, or if it is moved, always check that the booklet accompanies the boiler for reference by the new owner and/or installer.
- The installation and maintenance operations must be performed according to the standards in force, the instructions of the manufacturer and must be carried out by professionally qualified personnel.
- Incorrect installation or poor maintenance may cause a damage to persons or property. The manufacturer declines all liability for damage deriving from errors in the installation and maintenance of the appliance, and where there is a failure to observe the instructions provided by the manufacturer.
- Before performing any cleaning or maintenance operations, disconnect the appliance from the mains power supply using the system switch and/or the corresponding on-off devices.
- In the event of faults and/or poor operation of the appliance, it should be deactivated. Do not attempt to repair the appliance. Contact professionally qualified personnel only.
- The products must only be repaired-replaced by professionally qualified personnel, using original spare parts only. Failure to heed this warning may affect the safety of the appliance.
- To ensure the correct operation of the appliance, annual maintenance must be performed by qualified personnel.
- This appliance must only be used for the purposes it has specifically been designed for. All other uses are considered improper and thus dangerous.
- After having removed the packaging, check that the contents are intact.
- The parts of the packaging must not be left within the reach of children, as they are potential sources of danger.
- In case of doubt do not use the appliance and contact your supplier.



This symbol indicates **"Warning"** and is placed near all warnings regarding safety. Such provisions must be strictly adhered to so as to avoid danger and damage to persons and property.



This symbol highlights a note or an important warning.



### Certification

The CE Mark attests that Ferroli gas-fired appliances conform to the requirements specified in the corresponding European directives.

In particular, this appliance conforms to the following EEC directives:

- Directive 90/396, Gas Appliances,
- Directive 92/42, Efficiency,
- Directive 73/23, Low Voltage, (amended by no. 93/68)
- Directive 89/336, Electromagnetic Compatibility (amended by no. 93/68)



<b>1. User/operating instructions.....</b>	<b>4</b>
1.1 Introduction.....	4
1.2 Control panel .....	5
1.3 Ignition and shut down .....	5
1.4 Setting.....	6
1.5 Maintenance.....	6



<b>2. Installation .....</b>	<b>7</b>
2.1 General instructions .....	7
2.2 Place of installation .....	7
2.3 Water connections .....	9
2.4 Gas connection .....	11
2.5 Electrical connections .....	11
2.6 Flue connections .....	14



<b>3. Service and maintenance .....</b>	<b>20</b>
3.1 Settings .....	20
3.2 Commissioning.....	21
3.3 Maintenance.....	22
3.4 Replacement of parts.....	24



<b>4 Characteristics and technical specifications.....</b>	<b>28</b>
4.1 Dimensions and fittings .....	28
4.2 Overall view and main components .....	29
4.3 Hydraulic diagram.....	30
4.4 Technical data table .....	31
4.5 Diagrams .....	32
4.6 Wiring diagram .....	33

# 1. OPERATING/USER INSTRUCTIONS

## 1.1 Introduction

Dear Customer,

Thank you for having chosen the **SYS 10-23**, an advanced-concept FERROLI wall-hung boiler featuring cutting-edge technology, high reliability and constructional quality. Please carefully read this manual and leave it with the end user.

The **SYS 10-23** is a **high efficiency** heat generator for central heating systems, operating on natural gas or LPG.

The boiler can be connected to an external hot water cylinder for the production of domestic hot water.

The boiler body is made up of a **copper heat exchanger**, the special shape of which guarantees high heat exchange efficiency in all operating conditions, and an **atmospheric burner** featuring electronic ignition with ionisation flame control.

The boiler is completely **sealed** from the surrounding environment: the air required for combustion is taken in from the outside, and a fan is used to expel the flue gases. The accessories supplied with the boiler also include a variable-speed pump, expansion vessel, safety valve, air pressure switch, temperature sensors and safety thermostat.

The user simply has to set the temperature required inside the home (using the optional, yet recommended room thermostat) or set the system temperature and the required domestic hot water outlet temperature at the cylinder stat. The regulation and control system will then ensure optimum operation all year round.



## 1.2 Control panel

To access the control panel, open the drop down cover.

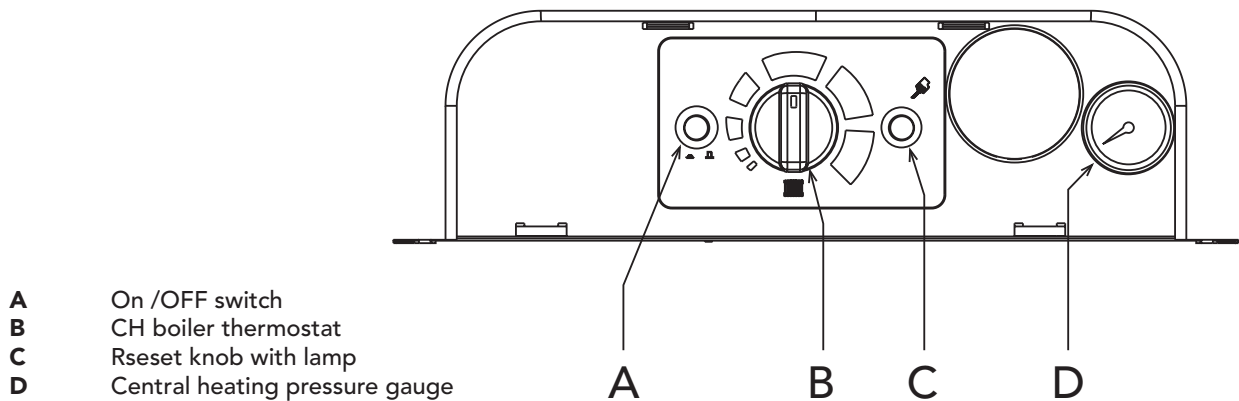

fig. 1

## 1.3 Ignition and shut-down

### Ignition

- Open the gas cock of the boiler.
- Vent air present in the pipe upstream of the gas valve.
- Turn on the switch (if present) or plug upstream of the boiler.
- Turn on the boiler switch
- Rotate the C.H. temperature adjustment knob above Min position.
- Check the external controls are calling for heat.
- At this point, the burner ignites and the boiler starts to function automatically, controlled by its control and safety devices.

If after completing the start-up procedure correctly, the burner fails to ignite and the boiler shut down warning lights up, wait about 15 seconds then press the reset switch. The reset electronic control unit will repeat the start-up cycle. If after a second attempt the burners still fail to ignite, consult the paragraph "Troubleshooting".

If there is a power failure while the boiler is in operation, the burners automatically go out and re-ignite when the power returns.

If the system is filled with very cold water, the boiler will automatically light due to the frost thermostat sensing the low temperature. The boiler will not shut down, until the water temperature reaches 10°C.

### Shut-down

Close the gas isolation valve upstream of the boiler, push the button "A" to OFF and disconnect the appliance from the mains power supply.

When the boiler power is off the boiler anti-freeze protection is not active. For extended periods of inactivity during the winter months, and in order to avoid damage due to freezing, all the water should be drained from the boiler; alternatively, place approved antifreeze fluid in the central heating system.

## 1.4 Settings

### **Setting the ambient temperature (using the optional room thermostat)**

Set, using the room thermostat, the temperature required inside the rooms. Based on the command from the room thermostat, the boiler is ignited and heats the system water to the set central heating outlet temperature. When the required temperature inside the rooms is reached, the boiler switches off. If no room thermostat is available, the boiler will maintain the system at the set central heating outlet temperature.

### **System water pressure control**

Manually filling the central heating system with external connection and cock. The filling pressure when the system is cold, as read on the boiler water pressure gauge, must be around 1.0 bar (at least 0.5 bar). If the pressure drops during operation to a value lower than the minimum described above, the User must restore the initial value using the filling loop. Once the operation is completed, always close the filling loop. This device is fitted to the system by the installer.

## 1.5 Maintenance

It is recommended to have annual service of the appliance performed by qualified personnel. Please refer to Chap. 3.3 in this manual for further information.

The casing, the control panel and the aesthetic parts of the boiler can be cleaned using a soft and damp cloth, dipped in soapy water if necessary. Do not use abrasive detergents or solvents.



## 2. INSTALLATION

### 2.1 General instructions

This appliance must only be used for the purposes it has been specifically designed for. This appliance is used to heat water to below boiling temperature at atmospheric pressure and must be connected to a central heating and/or hot warm distribution system, according to its characteristics, performance and heating capacity. All other uses are considered improper.



**THE BOILER MUST ONLY BE INSTALLED BY SPECIALIST AND QUALIFIED PERSONNEL, IN COMPLETE COMPLIANCE WITH ALL THE INSTRUCTIONS REPORTED IN THIS TECHNICAL MANUAL, THE LEGAL STANDARDS IN FORCE, THE PRESCRIPTIONS OF STANDARDS AND ANY LOCAL STANDARDS, AND ACCORDING TO THE RULES OF GOOD PRACTICE.**

Incorrect installation may cause damage to persons and property. The manufacturer will not be held liable in such events.

**This appliance must be installed strictly in accordance with these instructions.**

The Gas Safety Regulations (Installations & Use).

The Local Building Regulations.

The Building Regulations.

The Buildings Standards (Scotland - Consolidated) Regulations.

British gas publication DM2 - Guide for installation in timber framed housing.

British Standards Codes of Practice:

B.S. 7593	TREATMENT OF WATER IN DOMESTIC HOT WATER CENTRAL HEATING SYSTEMS
B.S. 5546	INSTALLATION OF HOT WATER SUPPLIES FOR DOMESTIC PURPOSES
B.S. 5440 Part 1	FLUES
B.S. 5440 Part 2	AIR SUPPLY
B.S. 5449	FORCED CIRCULATION HOT WATER SYSTEMS
B.S. 6798	INSTALLATION OF GAS FIRED HOT WATER BOILERS
B.S. 6891	GAS INSTALLATIONS
B.S. 7671	IEE WIRING REGULATIONS
B.S. 4814	SPECIFICATION FOR EXPANSION VESSELS
B.S. 5482	INSTALLATION OF LPG

Model Water Bye Laws

For Northern Ireland the rules in force apply

### 2.2 Place of installation

The appliance's combustion chamber is sealed from the surrounding environment and as a result the appliance may be installed in any room without purpose built ventilation. The installation environment must nonetheless feature sufficient ventilation, to avoid dangerous conditions arising in the event of even minor gas leaks. These safety standards are imposed by EEC Directive no. 09/396 for all gas appliances, including the so-called sealed appliances.

The place of installation must in any case be free of dust, inflammable objects or materials and corrosive gases. The environment must be dry and not prone to freezing.

The boiler is supplied ready for wall-hung installation. The rear frame of the appliance has a series of slots for fastening it to the wall, using screws with wall plugs. The fastening to the wall must provide stable and effective support of the appliance.

The boiler must be fastened to a closed part of wall, which is free of apertures or holes behind the frame of the boiler that may allow the internal components of the boiler to be reached.

If the appliance is enclosed in a cabinet or alongside another appliance, space must be allowed for normal maintenance operations. Fig. 2 and Tab. 3 show the minimum and recommended space to be left free around the appliance.



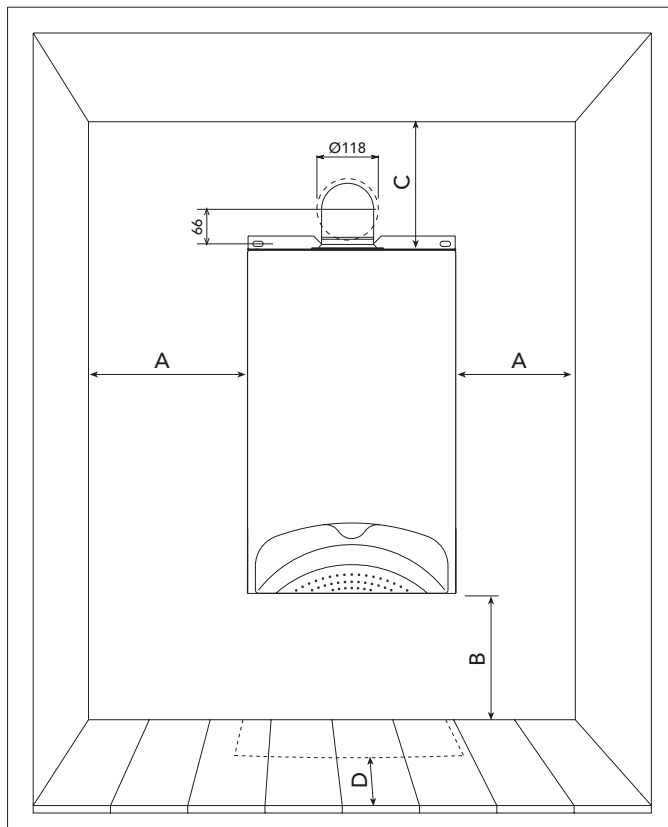

	Minimum	Recommended
A	30 mm	150 mm
B	200 mm	300 mm
C	280 mm	300 mm
D	15 mm (from opening panels)	> 600 mm

fig. 2

### Fixing to the wall

Select suitable mounting position for boiler, using the template mark flue outlet and boiler mounting points. Drill two 10mm holes 90mm deep to accept the wall plugs, fit wall plugs. Fit two special wall plugs on the wall as described in the fig. 3. Fasten the wall bracket to the wall using an antitheft nut on the right side and a standard nut (M8) on the left side. Mount the boiler on the wall bracket and fix using an antitheft nut on the left side and a standard nut (M8) on the right side. Using a core drill cut a 118mm diameter hole for the flue.

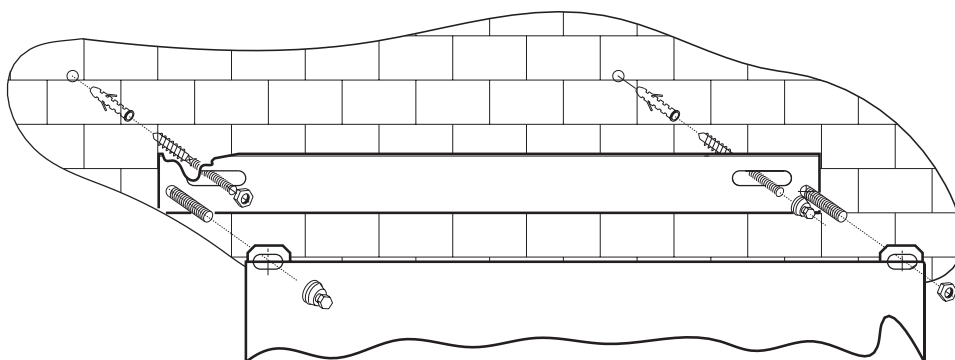

fig. 3



## 2.3 Water connections

The heat capacity of the appliance should be established in advance by calculating the heating requirements of the building according to the standards in force. For correct operation and long-life of the boiler, the hydraulic system must be suitably proportioned and always fitted with all the accessories that guarantee regular operation.

In the case where the central heating outlet and inlet pipes follow paths whereby, at some points, pockets of air may form, air vent valves should be installed at such points.

In addition, a drain device should be installed at the lowest point in the system, to allow complete draining.

If the boiler is installed at a lower level than the system, a flow-return valve should be fitted to prevent the natural circulation of water in the system.

The temperature differential between the outlet and the inlet of the boiler should not exceed 20°C.

Do not use the water pipes as the earth for electrical appliances.

Before installation, carefully clean all the pipes in the system to remove any residues or impurities that may affect the correct operation of the appliance.

Make the connections to the corresponding fittings, as shown in fig. 4.

### Key

- 1 Central heating outlet, 3/4"
- 2 Gas inlet, 1/2"
- 3 Central heating inlet, 3/4"

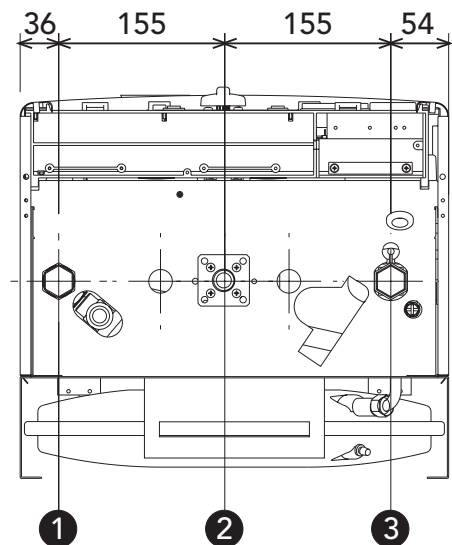

fig. 4

It is recommended to fit isolation valves between the boiler and the central heating system; these allow the boiler to be isolated from the heating system, if necessary.

The discharge of any safety valves must be routed to outside discharging to ground level 100 mm from the floor so as not to create a danger to anyone passing. The manufacturer of the boiler will not be held liable if this warning is not heeded, and the discharge valve intervenes and floods the room.

Make the connections to the boiler in a way that its internal tubing is not subject to stress.

## Make Up Water

Provision must be made for replacing water lost from the sealed system. Reference should be made to BS6798, for methods of filling and making up sealed systems. There must be no direct connection between the boiler's central heating system and the mains water supply. The use of mains water to charge and pressurise the system directly, is conditional upon the Local Water Byelaws. Again any such connection must be disconnected after use. The supplied temporary filling loop is shown in fig. 4. Ensure the filling point is on the return pipe to the boiler.

**Attention** - is drawn to the Model Water Byelaws.

Fittings manufactured from duplex (alpha-beta) brass are not acceptable for underground use and certain water undertakings will not accept their use above ground.



### Key

1. Filling point C.H.
2. Temporary connection
3. Cold water supply
4. Double check valve

Fig. 5

## Water treatment

if water treatment is used Ferroli Ltd recommend only the use of Fernox or Sentinel water treatment products, which must be used in accordance with the manufacturers instructions. For further information contact:

Fernox Manufacturing Co. LTD.	Sentinel Division
Tandern house, Marlowe Way	Betz Dearborn LTD
Croydon, surrey, CRO 4YS	Widnes, Cheshire WA8 5351
Tel. 02870 5601 5000	Tel. 0151 424 5351

**Note** - If the boiler is installed in an existing system any unsuitable additives must be removed by thorough cleansing.

All systems should be cleansed according to B.S. 7593.

**Note** - In hard water areas treatment to prevent lime scale may be necessary.

**Note** - It is important that the correct concentration of the water treatment product is maintained in accordance with the manufactures instructions.

## Filling the boiler and the system

The filling pressure, when the system is cold, must be around 1 bar (at least 0.5 bar). If the pressure drops during operation to a value lower than the minimum described above, the User must restore the initial value using the filling loop. For correct boiler operation, the pressure, when hot, must be around 1,5-2 bar. Once the operation is completed, always close the filling loop. This device is fitted to the system by the installer.

## 2.4 Gas connection

Before making the connections, check that the appliance is configured for operation with the type of fuel available, and carefully clean all the gas pipes in the system, to remove any residues that may affect the correct operation of the boiler.

The gas connections must be made using the relative coupling (see fig. 4), according to the standards in force, with a rigid metal pipe, or a stainless steel flexible continuous-wall pipe, fitting a gas cock between the system and the boiler. Check that all the gas connections for soundness.

The capacity of the gas meter must be sufficient for the simultaneous use of all the connected appliances. The diameter of the gas pipe, which leaves the boiler, does not necessarily determine the choice of the diameter of the pipe used between the appliance and the gas meter; this must be chosen according to its length and the pressure drop, according to the standards in force.

Do not use the gas pipes as the earth for electrical appliances.

## 2.5 Electrical connections

### Connection to the mains power supply

The boiler should be connected to a single-phase, 230 Volt-50 Hz electrical line.

The electrical safety of the appliance is ensured only when the appliance is correctly connected to an effective earth system, as prescribed by the safety standards in force. Have professionally qualified personnel check the efficiency and the rating of the earth system. The manufacturer is not liable for any damage caused by the appliance not being correctly earthed. In addition, make sure that the electrical system is adequately rated for the maximum power absorbed by the appliance, indicated on the boiler rating plate, and in particular that the cross-section of the wires is suitable for the power absorbed by the appliance.

The boiler is pre-wired and fitted with a cable for connection to the electrical line. The connections to the mains supply must be made using a fixed connection, featuring a double-pole switch with a contact opening of at least 3 mm. Max 3A fuses must be installed between the boiler and the line. The correct polarity must be followed (LINE: brown wire / NEUTRAL: blue wire / EARTH: yellow-green wire) in the electrical connections.

The appliance's power cable must not be replaced by the user. In the event where the cable is damaged, turn off the appliance and contact professionally qualified personnel to replace it. If replacing the electrical power cable.

All wiring must conform to current I.E.E. Regulations

### Accessing the electrical terminal block

Follow the operation shown in Figs. 6a and 6b to access the electrical terminal block. The layout of the terminals for the various connections is shown in the wiring diagram, in the chapter on Technical Specifications.



Fig. 6a

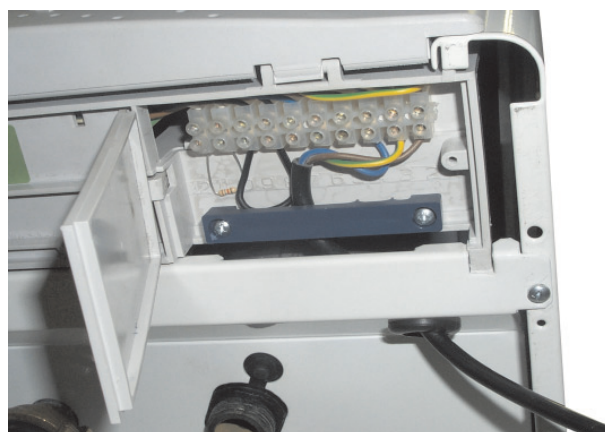

Fig. 6b

**Room thermostat**

**!** WARNING: THE ROOM THERMOSTAT MUST HAVE 230V LIVE CONTACTS.

**Standard Systems**

For a general pipe layout and wiring diagram on the "S" and "Y" plan systems please see fig. 7a, 7b, and 8a, 8b.

**SYS "S" Plan**

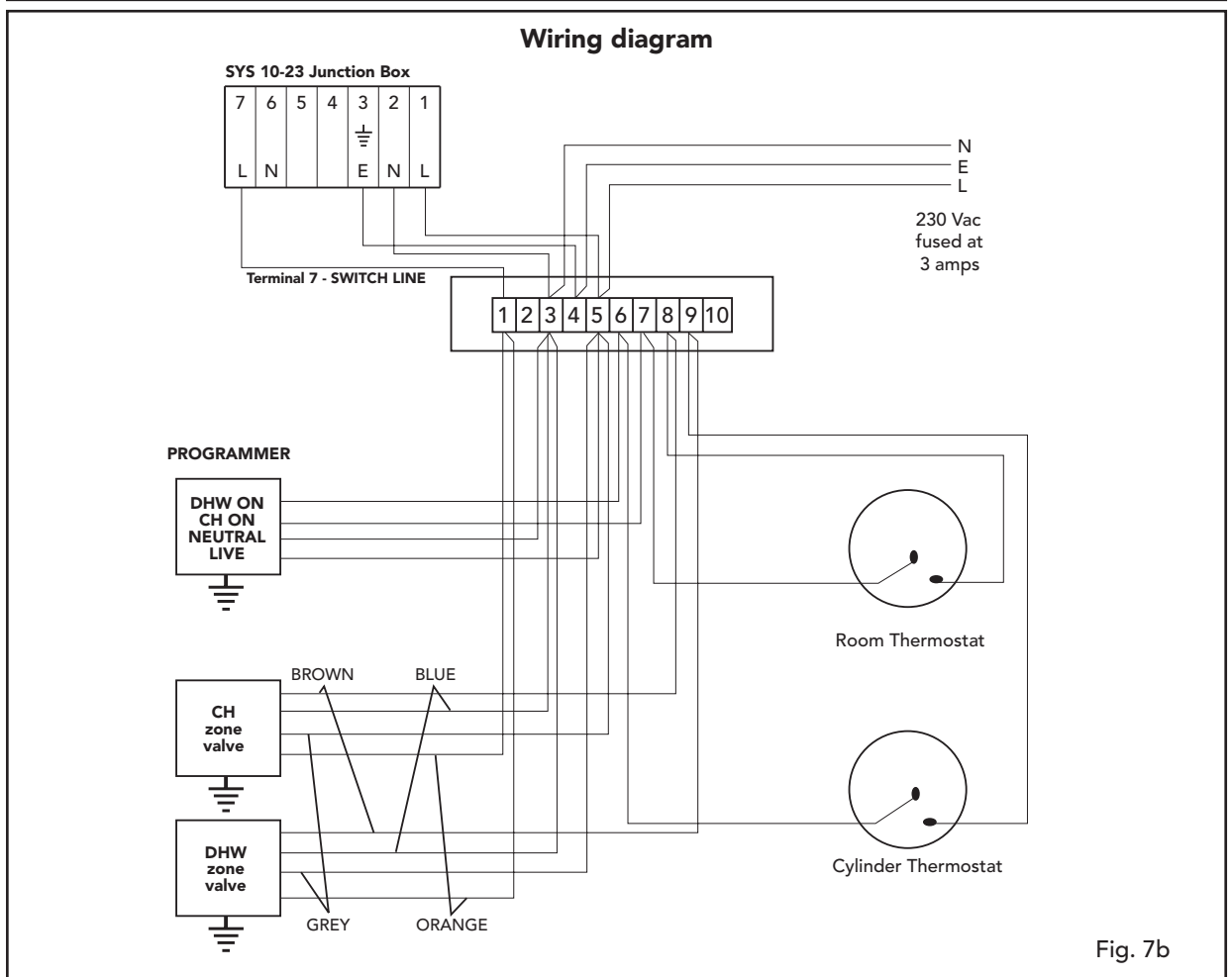
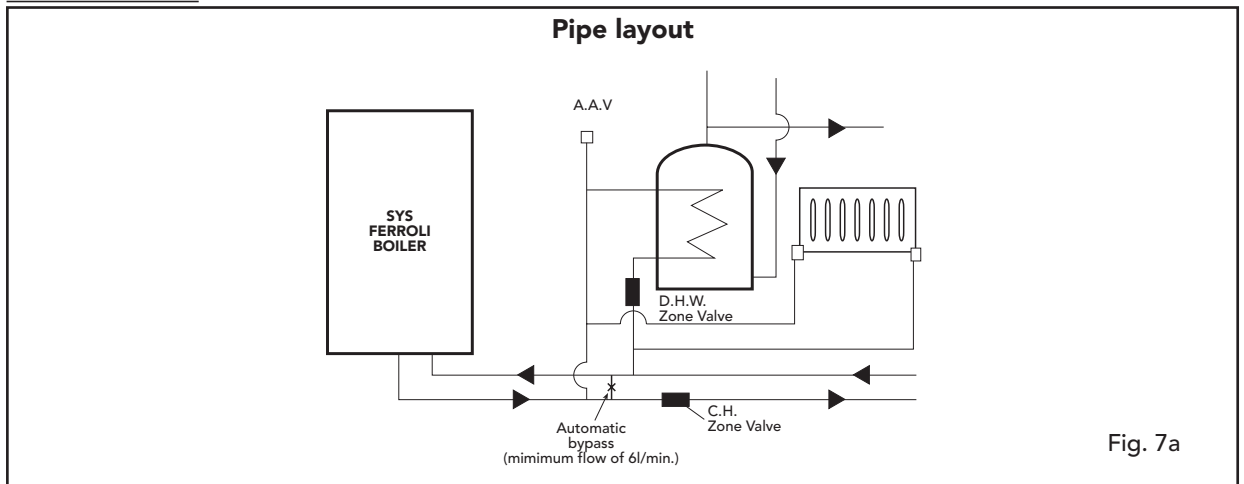

## Tempra 12/18 "Y" Plan

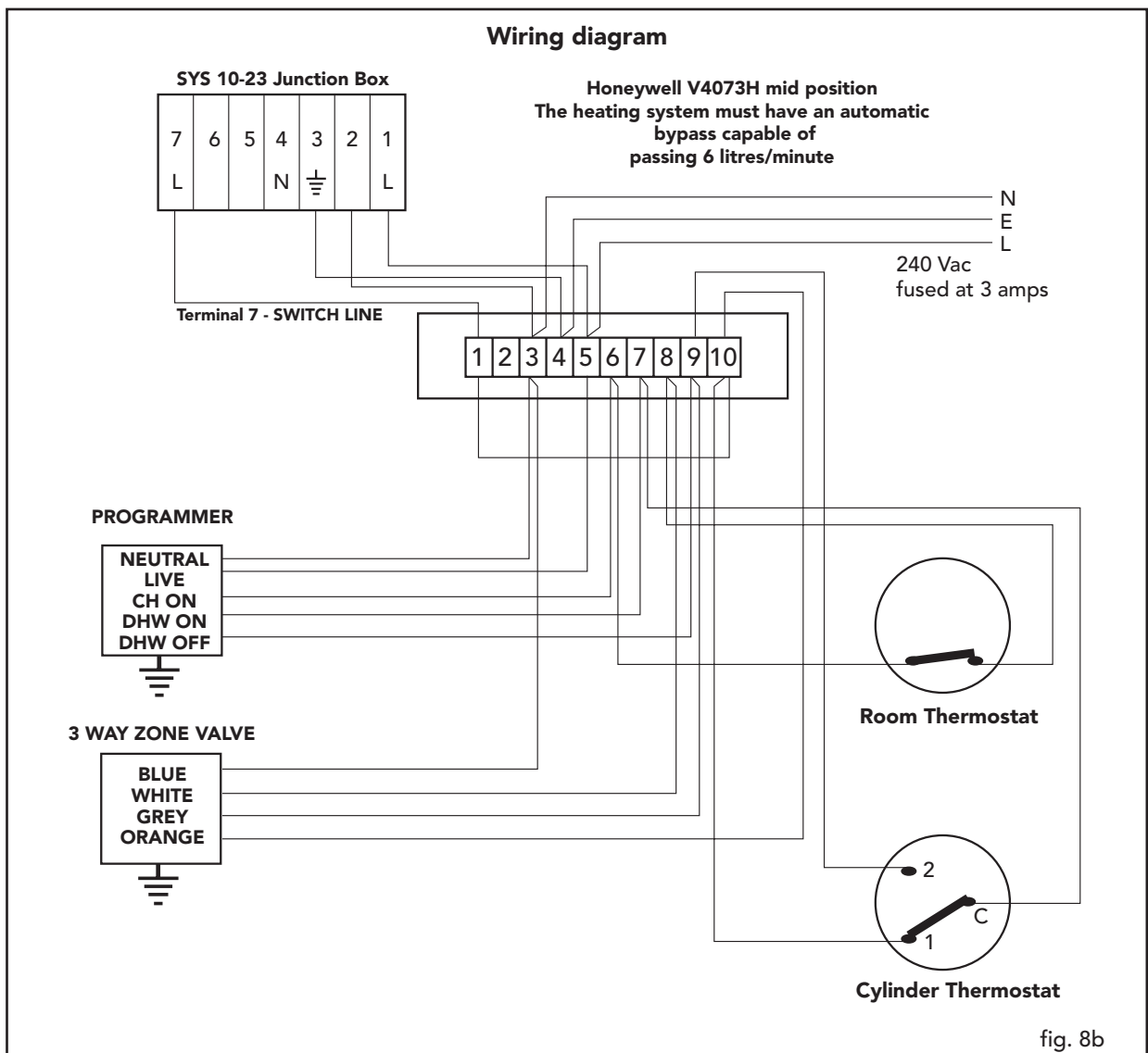
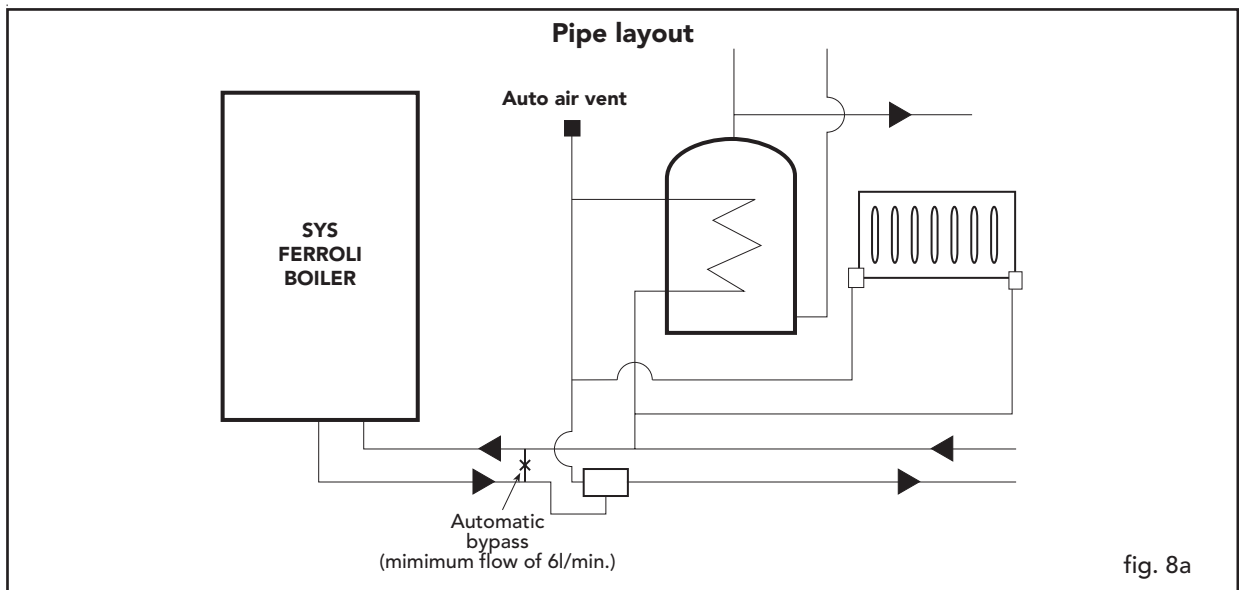

## 2.6 Flues connections

This is a "type C" **sealed** and forced draught appliance, and as such the air inlet and flue gas outlet must be connected to one of the exhaust/intake systems indicated below. Using the tables and the methods of calculation described, first verify, before installation, that the flues do not exceed the maximum allowed length. The standards in force and local legislation must be adhered to for terminal positions.

### Restrictors

For the operation of the boiler, the restrictors supplied with the appliance must be fitted, according to the indications shown in the tables below.

#### Choice of the restrictors using concentric flue

Type	Length up to:	Restrictor to be used
60/100	1 bend + 1 metre	50 mm
	1 bend + 3 metres	No restrictor
80/125	1 bend + 3 metres	45 mm
	1 bend + 4 metres	50 mm
	1 bend + 5 metres	No restrictor

#### Choice of the restrictors using 2 pipe system

Total calculated flue length		Use restrictor size mm
Minimum	Maximum	
0 m	10 m	45 m
10 m	20 m	47 m
20 m	35 m	50 m
35 m	45 m	No restrictor

### Replacing the restrictor

To install or change the restrictor, remove the fan unit, remove the flue gas connecting pipe 1 (as shown in Fig. 9a) and insert the diaphragm 2 (as shown in Fig. 9b).

**N.B.:** the diameter of the hole is stamped on the restrictor

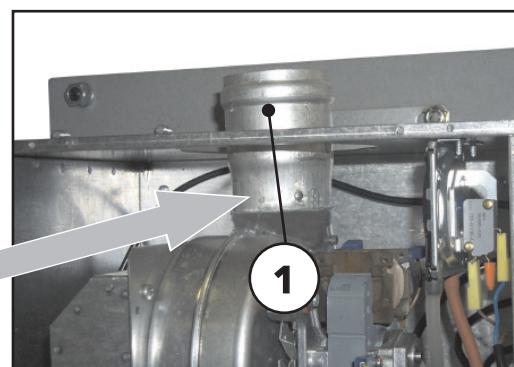
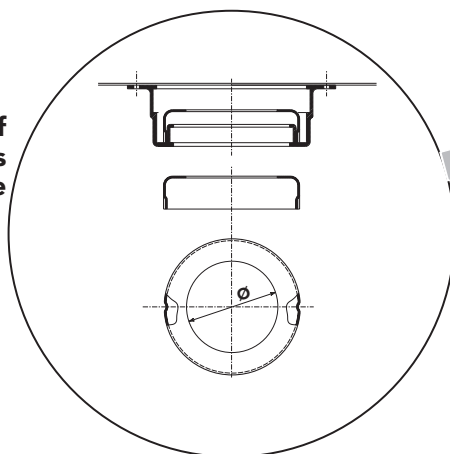

fig. 9a

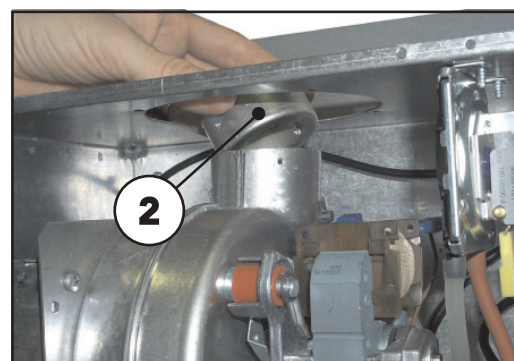

fig. 9b

The Ø45 SYS restrictor is fitted as standard on the boilers. Before inserting the flue gas outlet pipe, check that the correct restrictor is installed (when this needs to be used) and correctly positioned.

## Connection using concentric flue

For side outlet or roof outlet concentric air/flue gas pipe can be connected directly to the top of the boiler, or a special back flue outlet kit is available for Rear outlet. Numerous accessories are available upon request for the various different installation requirements. Please refer to the flue accessories catalogue, or the price list.

### Side Outlet

Front view

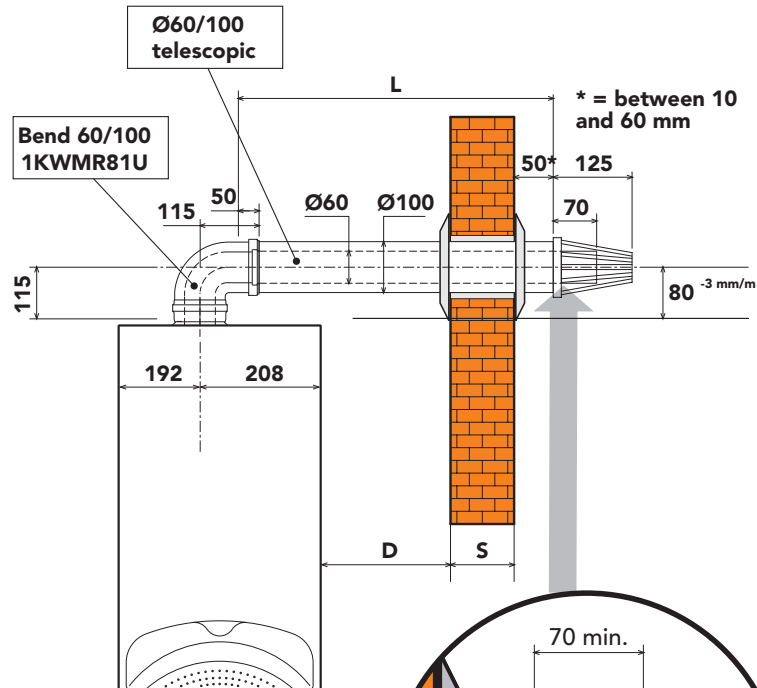

**Right hand**  
 $L = S + D + 263 \text{ mm}$

**Left hand**  
 $L = S + D + 247 \text{ mm}$

Top view

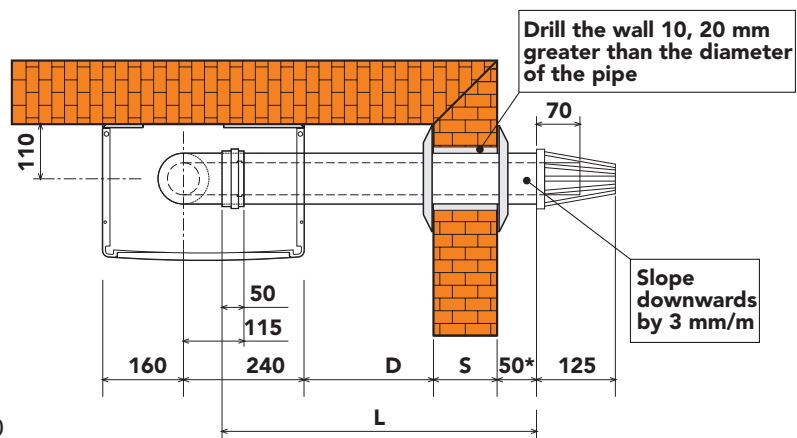

fig. 10

The total length in linear metres of the concentric pipes must not exceed the maximum length indicated in the table below, considering that each bend gives rise to the reduction indicated. For example, a D= 60/100 pipe with 1 x 90° bend + 1 metre horizontal + 2 x 45° bends + 1 metre horizontal, has a total equivalent length of 4 metres.

Maximum flue length permissible	Vertical	Horizontal*
100 mm concentric	4 m	3 m
125 mm concentric	5 m	

\* For horizontal Flueing the reduction for appliance bend or turret are already included.

Reduction for bend	
100 mm concentric bend 90°	1 m
100 mm concentric bend 45°	0,5 m
125 mm concentric bend 90°	0,5 m
125 mm concentric bend 45°	0,25 m

**For installation (top flue connection):**

1. Define the position for the installation of the appliance
2. Drill the wall for the passage of the air/flue gas pipe according to the references indicated in the figure, considering that the horizontal sections of pipe must have a downwards slope of around 3 mm per metre of length, to prevent any rainwater from entering the boiler.
3. Make a hole that is 10 - 20 mm greater in diameter than the rated diameter of the coaxial pipe used, to simplify its installation.
4. If necessary, cut the end of the pipes to measure, remembering that the outside part of the pipes must protrude from the wall by between 10 and 60 mm. Eliminate any burrs from the cut.
5. Connect the pipes to the boiler, placing the gaskets correctly, and seal the connections to the wall using the special seal couplings.

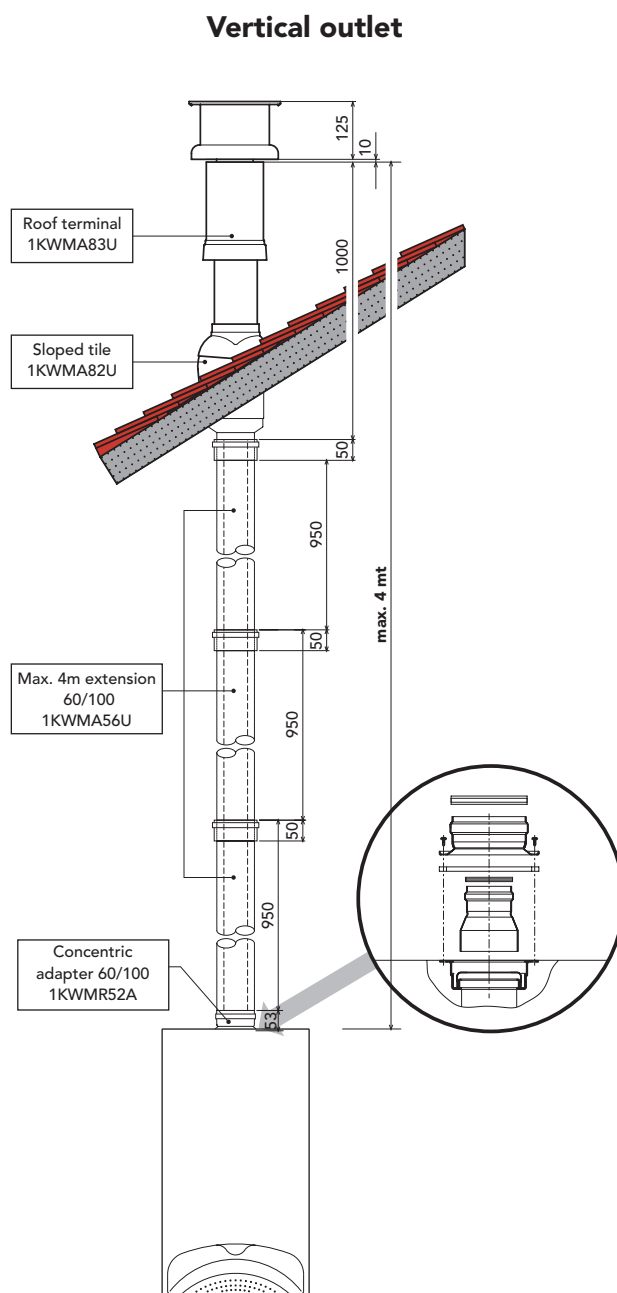

fig. 11



## Connection using two pipe system

The appliance may be connected to a system of separate air/flue gas pipes with wall or roof outlet, as shown in drawings 12 to the side. Numerous accessories are available upon request for the various different installation requirements. The most frequently-used components are shown in Tables 7 - 8 - 9. Please refer to the flue accessories catalogue or the price list for other components.

To check that the maximum allowed length of the pipes is not exceeded, a simple calculation must be performed before installation:

1. For each component, Tables 7 - 8 - 9 list a pressure drop in "equivalent air-metres", depending on the position of installation of the component itself (air intake or flue gas outlet, vertical or horizontal).

This drop is called "equivalent air-metres" as it relates to the pressure drop of one metre of air intake pipe (defined as being equal to 1). For example, a 90° bend in a Ø80 flue gas outlet has a pressure drop equivalent to 2.5 air-metres, that is, equal to 2.5 linear metres of air intake pipe.

2. Once having completely defined the layout of the double flue system, add the pressure drops in equivalent-metres, according to the position of installation of all the components and accessories in the system.

3. Check that the total pressure drop calculated is less than or equal to **45 equivalent metres**, that is, the maximum allowable for this model of boiler.

If the flue system chosen exceeds maximum allowable limit, some sections of the pipes should be larger in diameter.

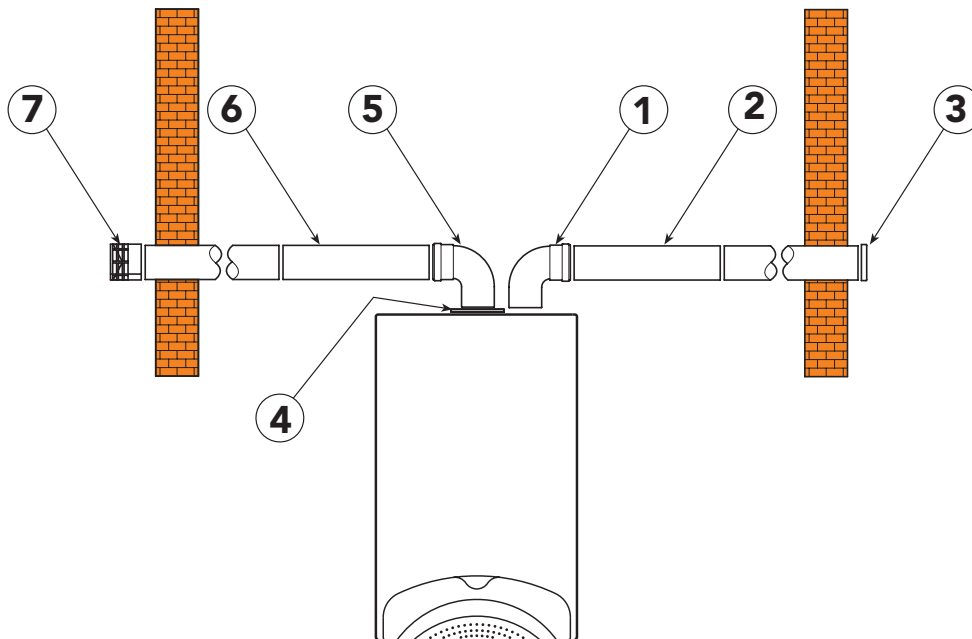

fig. 12

Ref.	N° Pieces	Description	Equivalent pressure drop
1	1	Air bend Ø80 R/D = 0,75	1,5 m
2	10	Horizontal air pipe	10,0 m
3	1	Air wall terminal	2,0 m
4	1	Air inlet closing flange	included
5	1	Flue bend 80 mm R/D = 0,75	2,5 m
6	12	Horizontal flue	24,0 m
7	1	Air wall terminal outlet flue	5,0 m
Total			45,0 m

## Pipes and fittings reduction table

Table 7		Description	Reduction			
			Air		Flue	
			Vertical	Horizontal	Vertical	Horizontal
<b>Accessories</b>	Male-female flue Ø80		1	1	1	2
	Female-female bend 45° Ø80		1,2		2,2	
	Female-female bend 90° Ø80		1,5		2,5	
	Male-female bend 90° Ø80		1,5		2,5	
	Pipe fitting M/M/F Ø80 with inspecting plug+trap for condensate drainage system				7	
	Condensate flue outlet				3	
	Spigot and socket reduction Ø80/100		0			
	Airwall terminal products of combustion Ø80					5
	Air terminal of inlet protection Ø80		2			

Table 8		Description	Reduction			
			Air		Flue	
			Vertical	Horizontal	Vertical	Horizontal
<b>Accessories</b>	Outlet flue air inlet for concentric system Ø80					
	Pipe fitting for outlet flue Ø80				4	
	Outlet flue air inlet for connection with split end Ø80					12

Table 9		Description	Reduction			
			Air		Flue	
			Vertical	Horizontal	Vertical	Horizontal
<b>Accessories</b>	Male-female flue Ø100		0,4	0,4	0,4	0,8
	Male-female bend 45° Ø100		0,6		1	
	Male-female bend 90° Ø100		0,8		1,3	
	Air wall terminal products of combustion Ø100					3
	Air terminal of outlet protection Ø100		1,5			
	Spigot and socket reduction Ø80/100		1,5		3	

The pressure drop values described refer to original Ferrolti pipes and accessories.

## Flue terminal positions

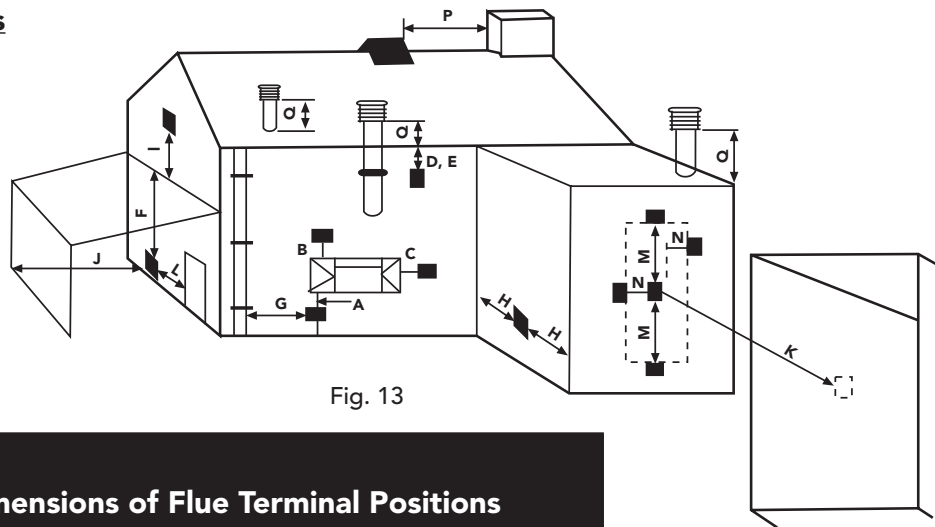

Fig. 13

Minimum Dimensions of Flue Terminal Positions		
<b>A<sup>a</sup></b>	Directly below an opening, air brick, opening windows, etc.	300mm
<b>B<sup>a</sup></b>	Above an opening, air brick, opening windows, etc.	300mm
<b>C<sup>a</sup></b>	Horizontally to an opening, air brick, opening windows, etc.	300mm
<b>D</b>	Below gutters, soil pipes or drain pipes	75mm
<b>E</b>	Below eaves	200mm
<b>F</b>	Below balconies or car port roof	200mm
<b>G</b>	From a vertical drain pipe or soil pipe	150mm
<b>H</b>	From an internal or external corner	100mm
<b>I</b>	Above ground roof or balcony level	300mm
<b>J</b>	From a surface facing the terminal	600mm
<b>K</b>	From a terminal facing the terminal	1200mm
<b>L</b>	From an opening in the car port (e.g. door, window) into the dwelling	1200mm
<b>M</b>	Vertically from a terminal on the same wall	1500mm
<b>N</b>	Horizontally from a terminal on the same wall	300mm
<b>O</b>	From the wall on which the terminal is mounted	N/A
<b>P</b>	From a vertical structure on the roof	150mm
<b>Q</b>	Above intersection with roof	300mm
<b>NOTE</b>		
N/A = Not applicable		
In addition, the terminal should not be nearer than 150mm (fanned draught) or 300mm (natural draught) to an opening in the building fabric formed for the purpose of accommodating a built-in element such as a window frame. Separation distances are linked to the rated heat inputs as shown.		
Condensing Terminal Positions: If the flue is to be terminated at low level, then the potential effect of the plume must be considered.		
The plume should not be directed: ● across a frequently used access route		
● towards a window or door		
● across a neighbouring property		

## 3. SERVICE AND MAINTENANCE

### 3.1 Settings

All the adjustment and conversion operations must be performed by Qualified Personnel, such as personnel from the Local Customer Service Centre.

FERROLI Ltd. declines all liability for damage to persons and/or things deriving from tampering with the appliance by non-authorized persons

Conversion of supply gas

The appliance can operate on Natural Gas or LPG as the supply gas, and is factory configured for use with one of the two gases, as is clearly marked on the packaging and on the rating plate on the appliance itself. If the appliance has to be used with a gas other than the one it has been set for, the special conversion kit must be used, as shown below:

- 1 Replace the nozzles in the main burner, installing the nozzles indicated in technical data table in Chap. 4.4, according to the type of gas used
- 2 Adjust the minimum and maximum pressures in the burner (ref. corresponding paragraph), setting the values indicated in technical data table for the type of gas used.
- 3 Change the position of Jumper 02 on the electronic board (ref. corresponding paragraph).
- 4 Apply the adhesive label in the conversion kit next to the rating plate, to confirm the conversion operation.

#### Adjusting the gas pressure and heat output

The following adjustments must be carried out by qualified personnel only.

To adjust boiler heat input simply adjust the burner pressure gas via the pressure regulator on the gas valve (fig. 14).

Adjust the gas pressure at the burner by turning the pressure regulating screw: turn it clockwise to increase the burner pressure and anticlockwise to decrease it.

The diagrams indicate the variation in heat output to the water as burner working pressure is varied (fig. 28).

Adjusting boiler output to the actual requirements of the central heating system will minimise boiler cycling thus saving fuel, varying the output has virtually no effect on the efficiency and combustion characteristics of the boiler.

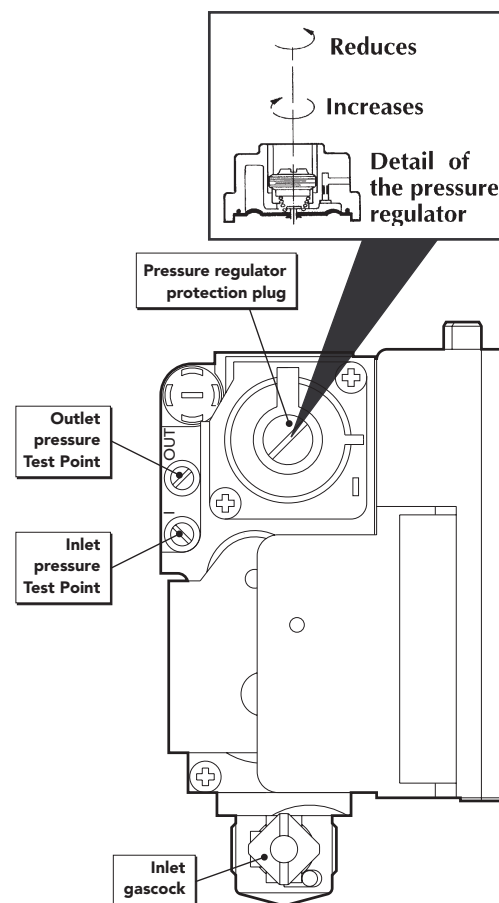

fig. 14

## 3.2 Commissioning



The appliance must only be commissioned for use by Qualified Personnel,

### **Before igniting the boiler:**

- Open any on-off valves between the boiler and systems.
- Check the gas system for soundness, proceeding with care and using a leak detection water solution to find any leaks from the connections.
- Fill the system with water and ensure that the air contained in the boiler and the system has been completely vented, by opening the air vent valve on the boiler and any vent valves in the system.
- Check that there are no water leaks in the heating system, in the domestic hot water circuits, in the connections or in the boiler.
- Check the correct connection of the electrical system.
- Check that the appliance is properly earthed.
- Check that the pressure value and gas rate for the heating system are correct.
- Check that there are no flammable liquids or materials in the immediate vicinity of the boiler.

### **Igniting the boiler**

- Open the gas isolation valve upstream of the boiler.
- Vent the air in the pipe upstream from the gas valve.
- Close any switches or insert any plugs upstream of the boiler
- Place the main switch in the ON position.
- Place knob "B" in the Winter position to a value higher than 50°C and set the room thermostat, if fitted, to the required temperature value. At this point, the burner will ignite and the boiler will start operating automatically, managed by its control and safety devices.
- Checking gas inlet pressure
  - Connect a pressure gauge to inlet test point;
  - Fire the Boiler and set at full gas rate by turning P3 to maximum (anticlockwise);
  - Check the pressure gauge is reading 20 mbar (+/-1 mbar);
  - Check that this pressure remains as above with any other gas appliances in the house turned on;
  - If the pressure is below this reading it should be investigated before continuing as this is a sign of an incorrect or partially blocked gas supply;
  - Turn-off appliance;
  - Remove pressure gauge, tighten test point and test with leak detection fluid.





If, after correctly having performed the ignition operations, the burners do not ignite and the shut-down warning light is on, wait around 15 seconds and then turn knob "A" (Fig. 1) to the RESET position and release it. The control unit will be reset and will repeat the ignition cycle. If, after a number of attempts, the burners do not ignite, refer to the paragraph "Troubleshooting".



In the case of power failures while the boiler is in operation, the burners will switch off. When mains power returns, the burners will automatically re-ignite.

### **Checks during operation**

- Check the gas supply and the water system for tightness.
- Check the efficiency of the flues and air-flue gas pipes during the operation of the boiler.
- Check that the water circulation between the boiler and the systems is correct.
- Ensure that the gas valve modulates correctly both in the central heating phase and the production of domestic hot water.
- Check the correct ignition of the boiler, by performing a series of ignition and shut-down tests using the room thermostat or the remote control.
- Ensure that the consumption of gas indicated by the counter corresponds to the values shown in the technical data table in Chap. 4.

### **Shut-down**

Close the gas isolation valve upstream of the boiler and disconnect the appliance from the mains power supply.



For extended periods of inactivity during the winter months, in order to avoid damage due to freezing, all the water should be drained from the boiler, both the domestic hot water and the central heating system; alternatively, drain only the domestic hot water and place the special antifreeze fluid in the central heating system.

## **3.3 Maintenance**



The following operations must only be performed by Qualified Personnel

### **Seasonal checks on the boiler and the stack**

The following checks should be made on the appliance at least once a year:

- The control and safety devices (gas valve, flow-meter, thermostats, etc.) must be working properly.
- The pipes and the air-flue gas terminals must be free of obstacles and not have any leaks.
- The water systems must be perfectly tight and the gas supply sound.
- The burner and the heat exchanger must be clean. Follow the instructions in the next paragraph.
- The electrodes must be free of deposits and positioned correctly.
- The pressure of the water in the system when cold must be around 1 bar; if not, restore this value.
- The expansion vessel must be full.
- The gas rate and the pressure must correspond to the values indicated in the corresponding tables.
- The circulation pumps must not be blocked.

## Opening the casing

To open the boiler casing:

- 1 Using a screwdriver, completely remove the 2 screws, "A"
- 2 Open the control panel "B" by pulling down
- 3 Unscrew the 2 screws "C"
- 4 Remove the casing "D".

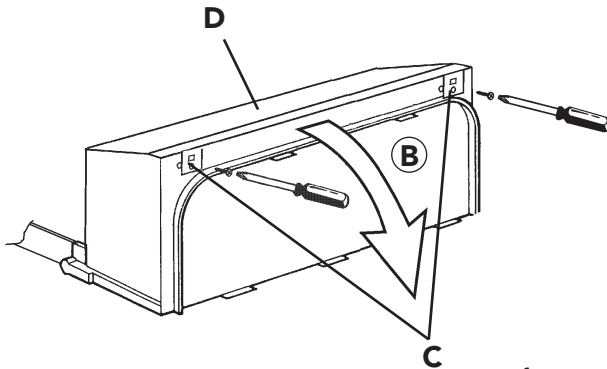
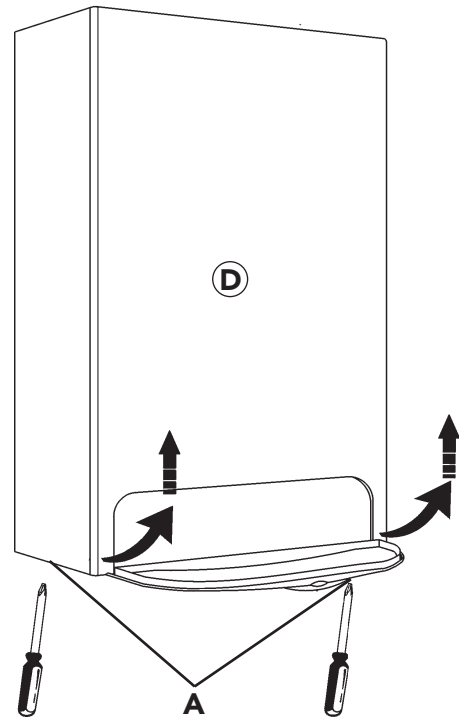

fig. 15



## Cleaning the boiler and the burner

The body and the burner must not be cleaned using chemical products or steel brushes. Special care must be taken to ensure all the systems relating to the sealed compartment are tight (gaskets, cable glands, etc..), to avoid air leaks which, causing a drop in the pressure inside in chamber, may activate the differential pressure switch and thus shut-down the boiler. Special attention must also be paid, after all the operations have been completed, to checking and performing all the ignition phases and operation of the thermostats, gas valve and circulation pump.



After these checks, ensure that there are no gas leaks.

## Analysis of combustion

Two test points are installed inside the boiler, one for the flue gases and the other for the intake air. To make the measurements, proceed as follows:

- 1) Remove the boiler casing
- 2) Open the air and flue gas sample points in the sealed compartment;
- 3) Insert the probes as far as possible;
- 4) Open a hot water tap;
- 5) Adjust the domestic hot water temperature to the maximum setting.
- 6) Wait 10-15 minutes to allow the boiler to reach stable operating conditions\*
- 7) Take a reading with your flue gas analyser.
- 8) CO/CO<sub>2</sub> ratio should be 0.004 or below. If above a full service is required to find the cause and then RE-TEST.
- 9) Following a full service the permissible reading is now 0.008 or below.

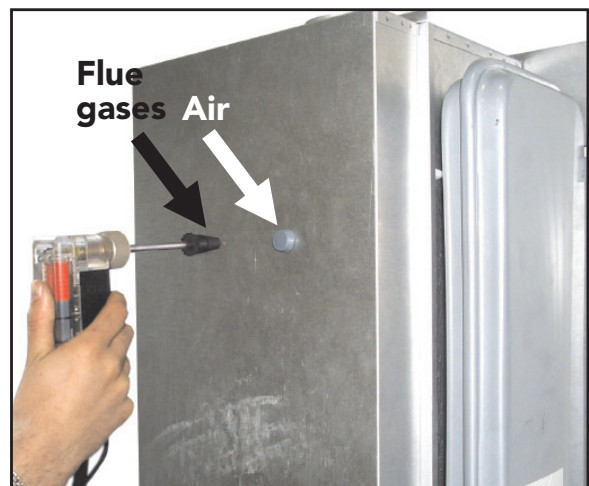

Testing before thermal equilibrium has been reached will give incorrect readings. fig. 16

### 3.4 Replacement of Parts

#### Initial procedure

- a) The boiler is cold, electricity supply is isolated, and the gas supply is turned off at the inlet of the boiler
- b) For replacement of parts where water connections are broken, it will be necessary to isolate and drain either or both the central heating or domestic hot water circuits of the boiler only. The cold water mains inlet is isolated at the inlet cock. The D.H.W. is drained by opening a hot tap. The C.H. flow and return cocks are turned off at the isolation cocks. The C.H. is drained via the pressure relief valve (twist about 1/3 of a turn).
- c) Remove components following special notice below and replace in reverse order.
- d) Ensure water and gas washers are in good condition.

#### Final procedure

- Re-open cocks and re-charge the system to about 1 bar, and vent boiler and radiators. Re-charge to 1 bar if necessary.
- Upon completion of the work the following, should be checked:
  - I) Gas soundness of all joints
  - II) Water soundness of all joints
  - III) The electricity supply.
  - IV) The pressure of the sealed system and top up where necessary.

#### To lower the control panel

- Remove the two fixing screw "A"
- Rotate down the front panel "B"

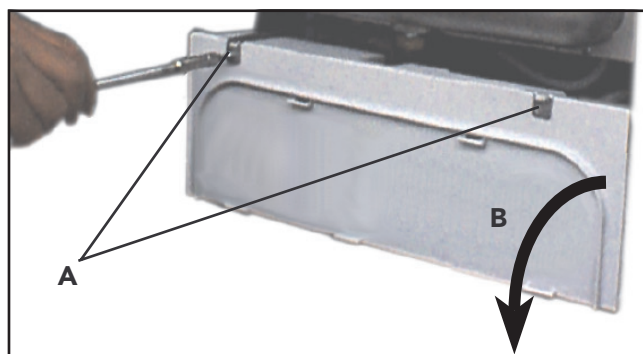

fig. 17

#### Remove and re-pressurising of C.H. expansion vessel

- Refer to 7.01 a, b
- Isolate electricity and water supplies
- Remove outer case (two screws bottom rear corners)
- Loosen the "A" connections to expansion vessel
- Remove "B" screw
- Remove the expansion vessel
- Re-assemble in reverse order
- Re-pressure expansion vessel (charge pressure 0,8-1 bar) through the valve "C"
- Ensure pressure relief valve is open (twist about 1/2 of a turn) when repressurizing

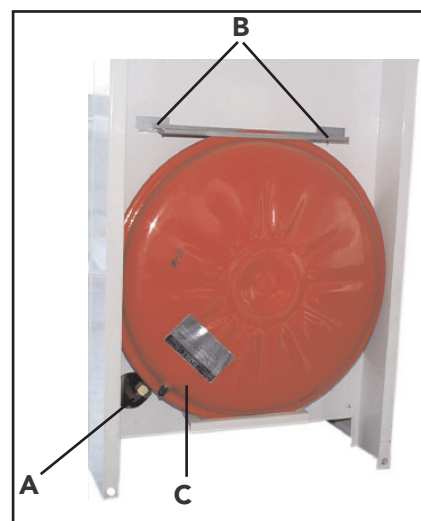

fig. 18



## Gas valve (fig. 19)

- Isolate gas and electricity supplies
- Remove outer case (two screws bottom rear corners)
- Remove the two securing screws and lower control panel
- Disconnect electrical connections from valve ("A")
- Disconnect plastic tube "C"
- Loosen the connection "D" on gas pipe and the gas inlet connection of the boiler "E"
- Remove the two fixing screw "E" below gas valve
- Slide out gas valve
- Remove four fixing screw "F" on top of the valve and disconnect the gas pipe
- Remove bottom connection from gas valve.
- Fit top + bottom gas connections to the new gas valve and replace in reverse order

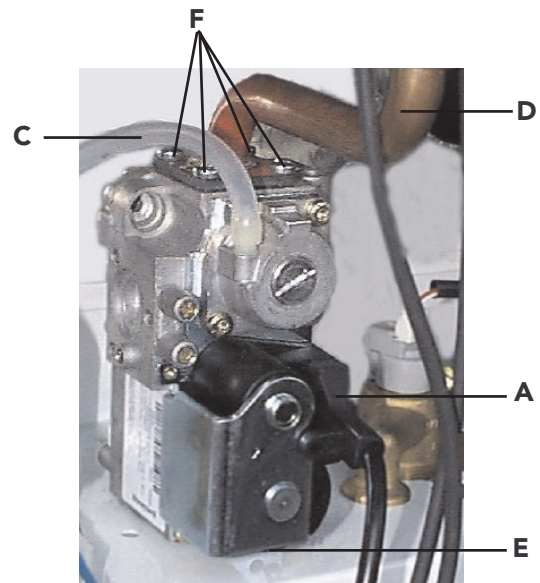

Fig. 19

## Air pressure switch (fig. 20)

- Isolate electricity
- Remove outer case (two screws bottom rear corners)
- Open room sealed department
- Remove the two screw "A" fixing air pressure switch
- Disconnect electrical leads "B"
- Remove pressure sensing tubes (white=D; Red=C)
- Note relevant positions of all connections and replace in reverse order.

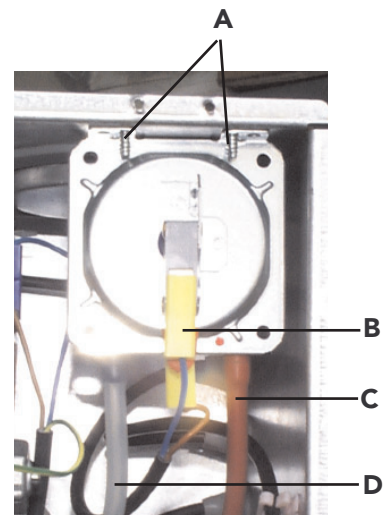

Fig. 20

## Safety Valve (fig. 21)

- Isolate electricity and water supplies
- Remove outer case (two screws bottom rear corners)
- Remove the two securing screws and lower control panel
- Identify valve from fig. 21
- Drain the boiler
- Release the outlet union to the valve and undo the valve union connection
- Remove the valve outlet fitting
- Replace in reverse order

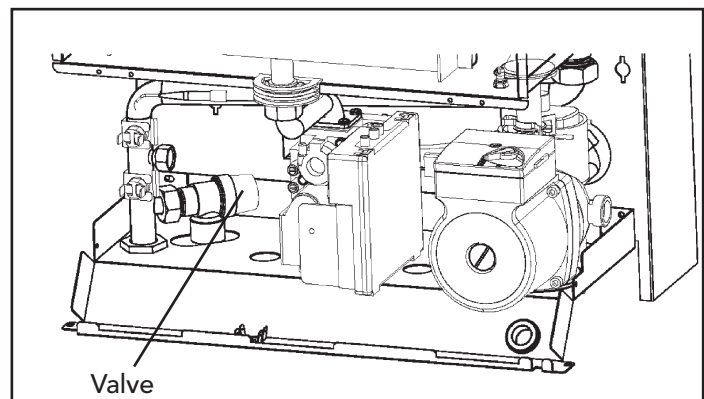

Fig. 21

**Removal of burner (fig. 22)**

- Isolate gas and electricity supplies
- Remove outer case (two screws bottom rear corners)
- Remove room sealed cover
- Disconnect ignition and flame rectification leads "A"
- Undo gas rail union "B"
- Undo two screws securing the burner assembly to the boiler combustion chamber "D"
- Withdraw the burner assembly

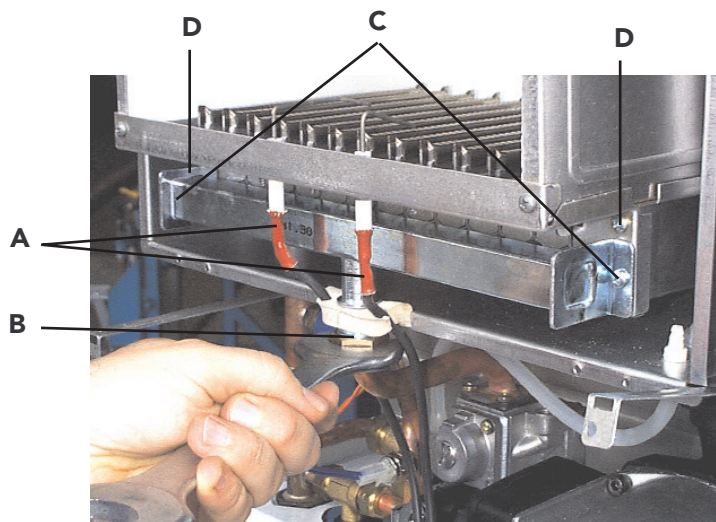

fig. 22

**Injectors (fig. 22)**

- Proceed as 7.08
- Remove fixing screw "C" on both sides of gas collector
- Remove gas collector
- Unscrew and remove injectors;
- Clear or change injectors

**Removal of fan (fig. 23)**

- Isolate gas and electricity supplies
- Remove outer case (two screws bottom rear corners)
- Remove room sealed cover
- Disconnect fan electrical leads "A" and note positions
- Disconnect air pressure tubes from air pressure switch "B" + note positions
- Undo two screws securing fan assembly "C"
- Remove fan from boiler
- Swap mounting plate over to new fan + replace in reverse order

**Limit thermostat, or overheat cut off thermostat (fig. 23)**

- Isolate electricity
- Remove outer case (two screws bottom rear corners)
- Remove room sealed cover
- Identify the location of thermostat from
- Pull out thermostat from tube, with its spring
- Remove electrical connections from thermostat
- Remove spring from thermostat
- Replace in reverse order

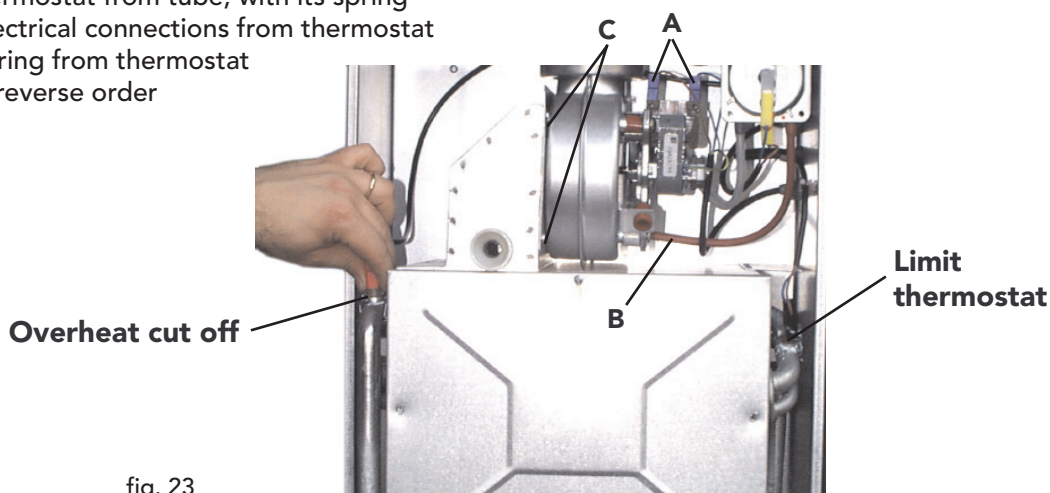

fig. 23

## **Spark or flame detect electrode (fig. 24)**

- Isolate gas and electricity supply
- Remove outer case (two screws bottom rear corners)
- Open room sealed compartment and combustion chamber
- Identify electrode from fig. 24
- Unplug electrical connection "A" from sensing electrode
- Remove fixing screw and remove flame detect electrode
- Remove the two fixing screw from spark electrode plate and remove it.

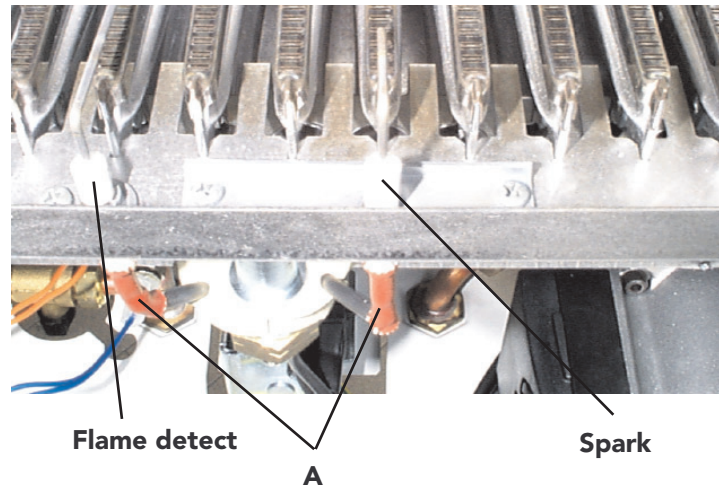

Fig. 24

## **Pump**

### **Replacement of pump head**

- Isolate electricity and flow and return pipes
- Remove casing (two screws bottom rear corners).
- Remove the two securing screws and lower control panel
- Release pressure from boiler via pressure relief valve
- Unplug the pump lead from the pump head
- Place a piece of cloth or other absorbent material over the rear of the control panel to catch any drops of water that may fall when the pump head is removed.
- Using a 4mm allen wrench undo the four allen screws in the pump head, lift away pump head from the pump body
- fit new head into pump body and secure with the allen screws tightening evenly.
- Replace electrical connection.

### **Removal of heat exchanger**

- Isolate gas, water and electricity supplies
- Remove casing (2 screws bottom corners)
- Remove the two securing screws and lower control panel
- Drain heat exchanger for both CH + DHW
- Remove sealed compartment front panel
- Disconnect the overheat thermostat and central heating limit thermostat
- Remove the main burner, fan, flue hood and flow meter as described previously
- Remove the pump to heat exchanger flow connection and locknut
- Undo the domestic water outlet connection and locknut
- Lift out heat exchanger
- Re-assemble in reverse order

## 4. CHARACTERISTICS AND TECHNICAL SPECIFICATIONS

### 4.1 Dimensions and fittings

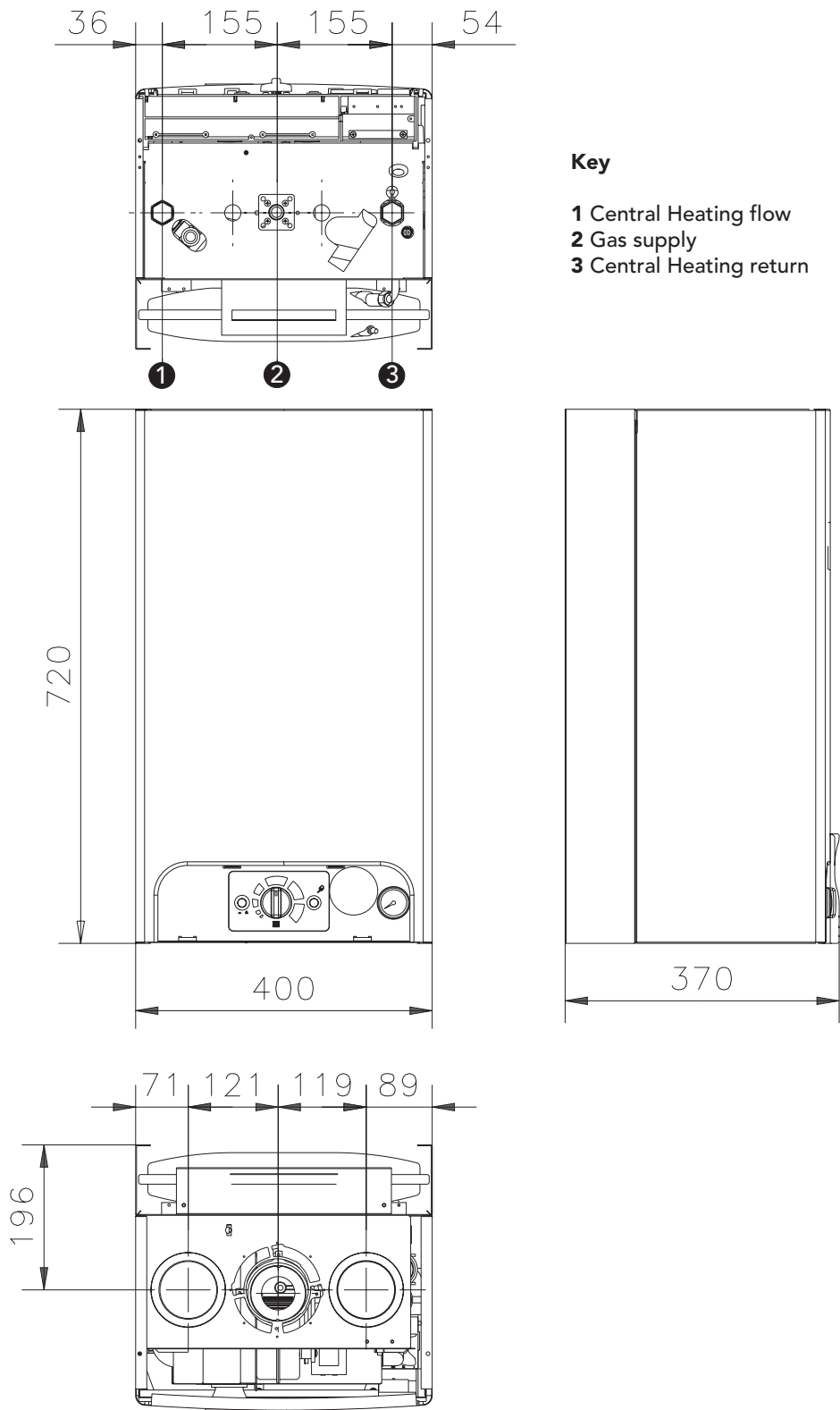
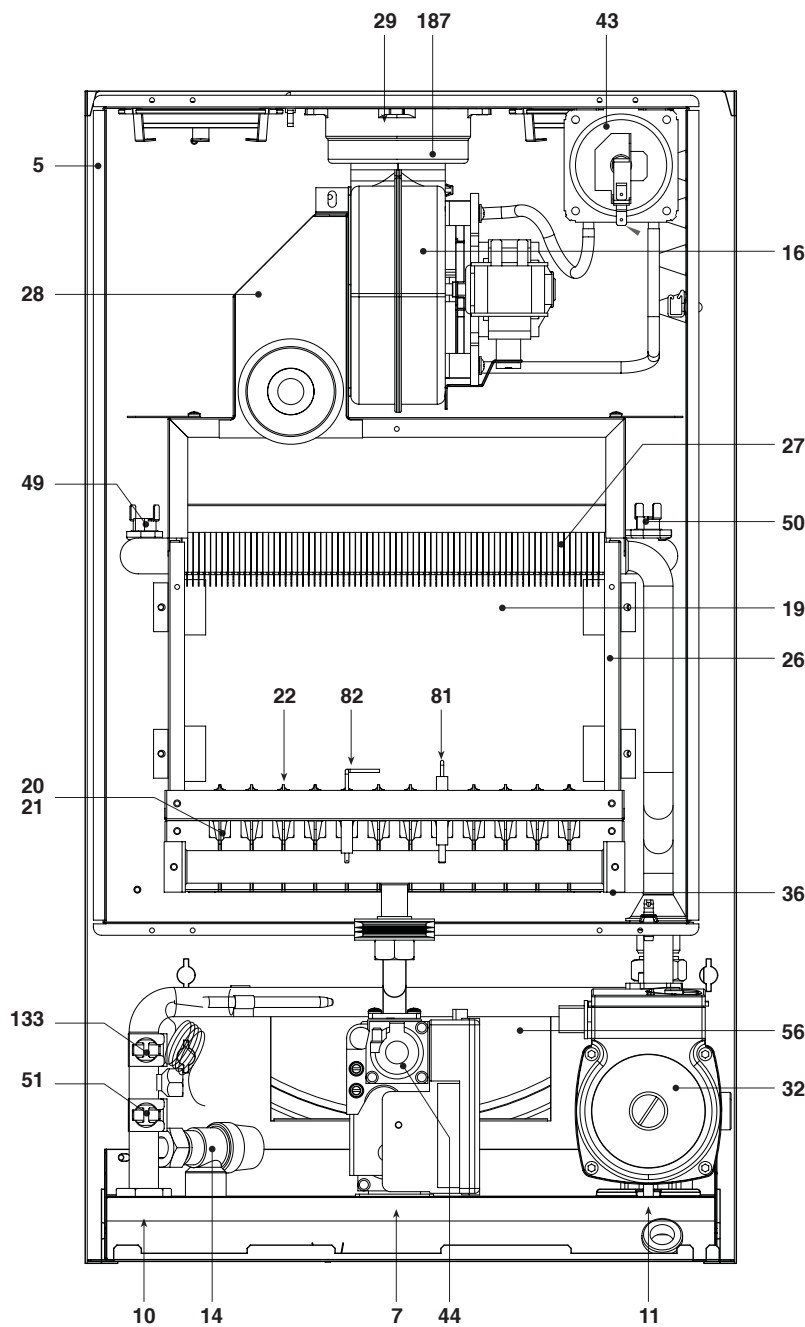

fig. 25

## 4.2 Overall view and main components



### Key

- 5** Room sealed compartment
- 7** Gas inlet
- 10** Central heating flow
- 11** Central heating return
- 14** Safety valve
- 16** Fan
- 19** Combustion chamber
- 20** Burner assembly
- 21** Main injector
- 22** Burner
- 26** Combustion chamber insulation
- 27** Copper heat exchanger
- 28** Flue collector from heat exchanger
- 29** Internal flue exit
- 32** Central heating pump
- 36** Automatic air vent valve
- 43** Air pressure switch
- 44** Gas valve
- 49** Safety overheat thermostat
- 50** Central heating flow limit thermostat
- 51** Central heating frost thermostat
- 56** Expansion vessel
- 63** CH boiler thermostat
- 81** Ignition electrode
- 82** Sensor electrode
- 129** Reset knob with lamp
- 133** Pump overrun thermostat
- 145** Central heating pressure gauge
- 187** Flue restrictor
- 188** ON/OFF switch

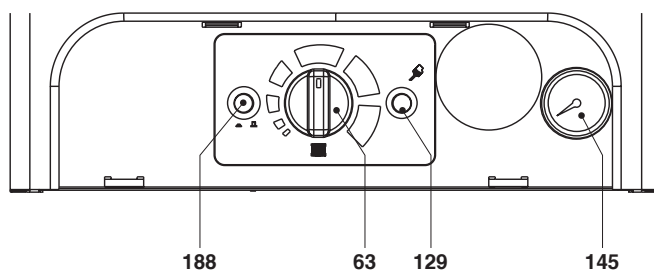

fig. 26

**4.3 Hydraulic diagram**

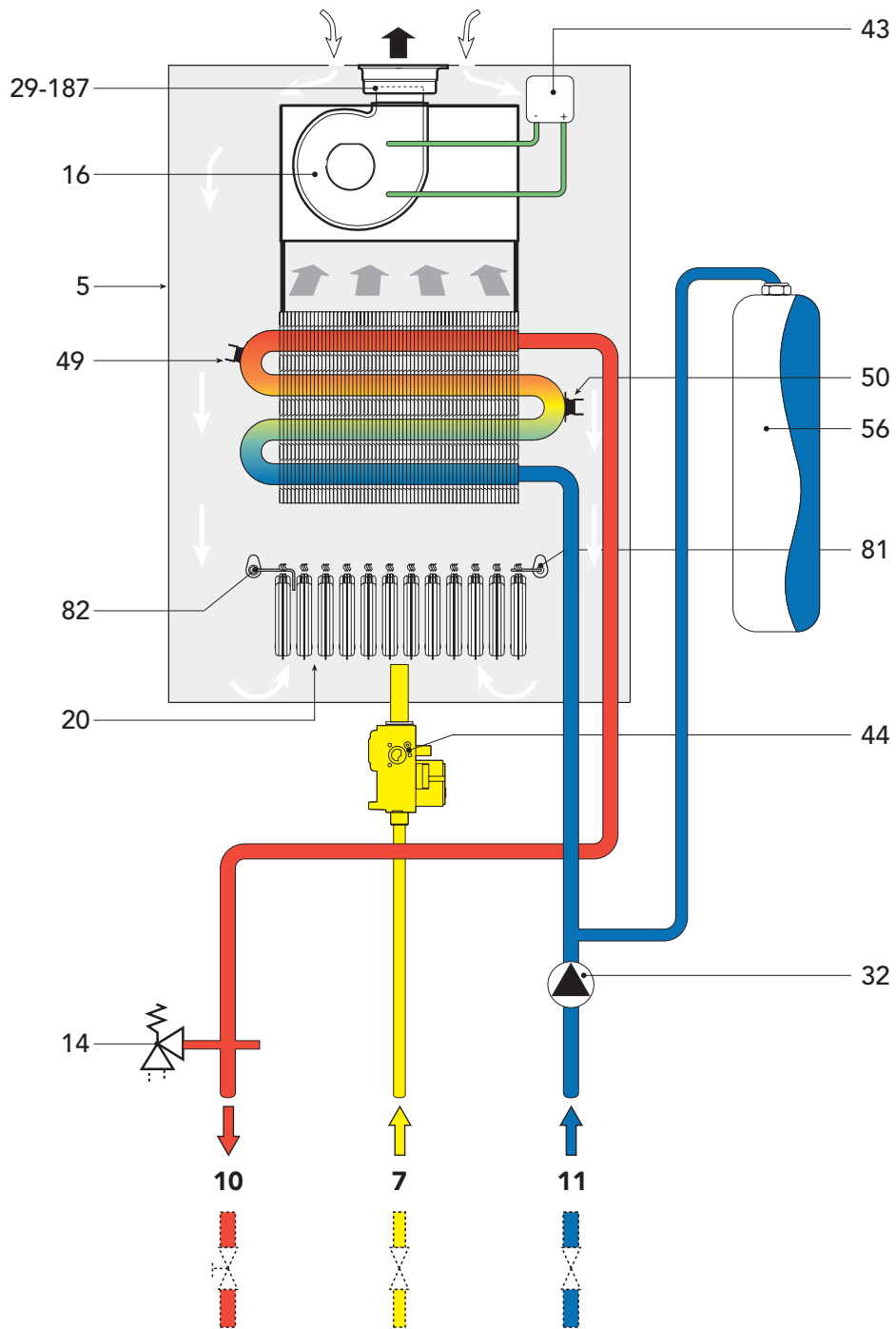

fig. 27

**Key**

- |                                  |   |
|----------------------------------|---|
| <b>5</b> Room sealed compartment | <b>43</b> Air pressure switch                   |
| <b>7</b> Gas inlet               | <b>44</b> Gas valve                             |
| <b>10</b> Central heating flow   | <b>49</b> Safety overhear thermostat            |
| <b>11</b> Central heating return | <b>50</b> Central heating flow limit thermostat |
| <b>14</b> Safety valve           | <b>56</b> Expansion vessel                      |
| <b>16</b> Fan                    | <b>81</b> Ignition electrode                    |
| <b>20</b> Burner assembly        | <b>82</b> Sensor electrode                      |
| <b>29</b> Internal flue exit     | <b>187</b> Flue restrictor                      |
| <b>32</b> Central heating pump   |   |

## 4.4 Technical data table

<b>Output</b>		<b>Pmax</b>	<b>Pmin</b>
Nominal Heat Input (Net)	kW	25,8	11,2
Nominal Heat Output	kW	23,3	9,7
<b>Gas supply</b>		<b>Pmax</b>	<b>Pmin</b>
Main injectors, Natural Gas (G20)	mm	12 x 1.3	
Supply pressure, Natural Gas (G20)	mbar	20,0	
Burner pressure, Natural Gas (G20)	mbar	11,8	2,5
Natural gas rate (G20)	nm <sup>3</sup> /h	2,73	1,19
Main injectors, LPG (G31)	mm	12 x 0.77	
Supply pressure, LPG (G31)	mbar	36,0	
Burner pressure, LPG (G31)	mbar	36,0	7,0
LPG gas rate (G31)	kg/h	2,00	0,87
<b>Central heating</b>			
Maximum central heating operating temperature	°C	90	
Maximum central heating operating pressure	bar	3	
Safety valve	bar	3	
Minimum central heating operating pressure	bar	0,8	
Expansion vessel capacity	litres	7	
Expansion vessel pre-fill pressure	bar	1	
Hot water capacity	litres	1,5	
<b>Dimensions, weights, fittings</b>			
Height	mm	720	
Width	mm	400	
Depth	mm	370	
Weight with packaging	kg	35	
Gas system fittings	inches	1/2"	
System filling fittings	inches	1/2"	
Central heating system fittings	inches	3/4"	
<b>Power supply</b>			
Max Power Absorbed	W	125	
Power supply voltage/frequency	V/Hz	230/50	
Index of protection	IP	X4D	

## 4.5 Diagrams

### Pressure - output diagrams

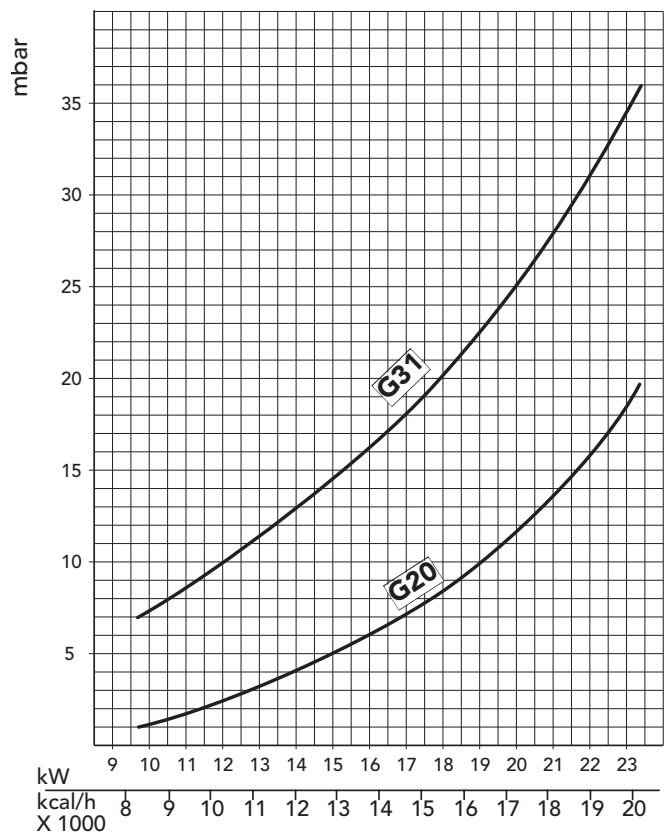
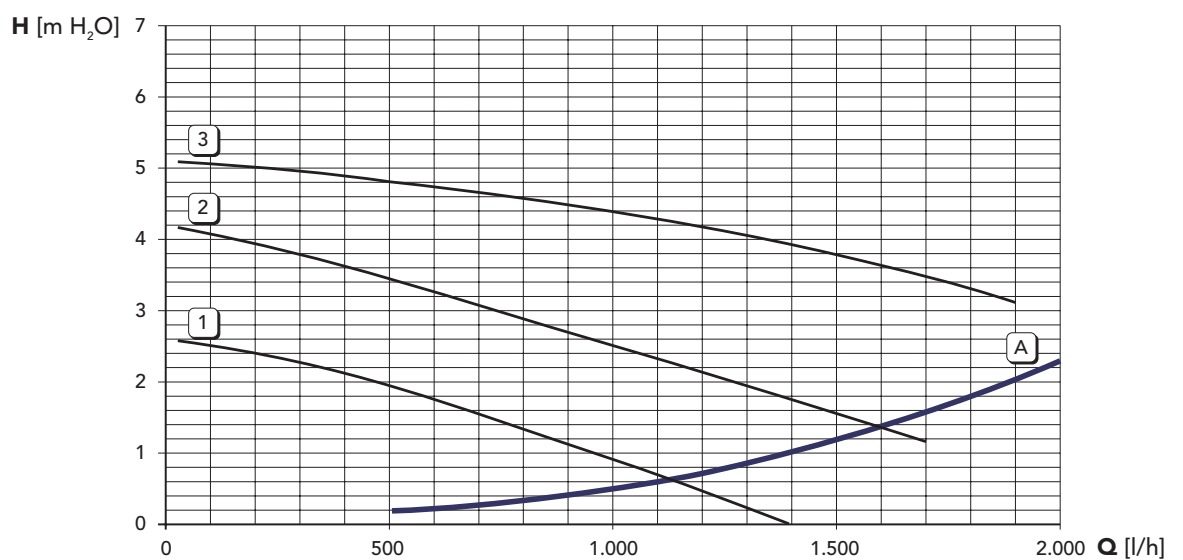

fig. 28

### Discharge head available to system



**Legenda**

- 1 - 2 - 3 = Pump switch positions
- A = Boiler pressure drop

fig. 29



## 4.6 Internal electrical diagrams

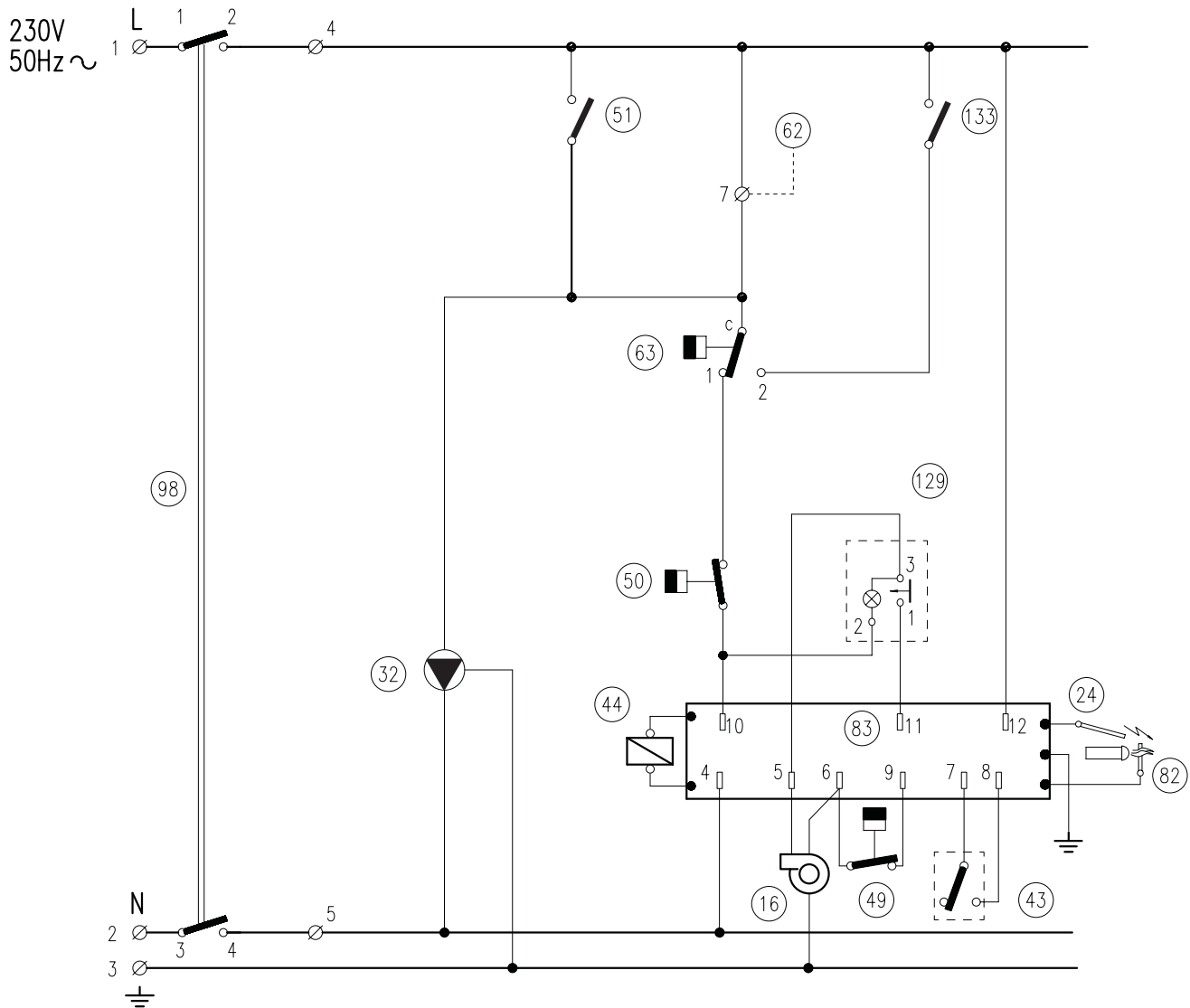

fig. 30a

- 16 FAN
- 24 SPARK ELECTRODE
- 32 CENTRAL HEATING PUMP
- 43 AIR PRESSURE SWITCH
- 44 COMBINATION GAS VALVE
- 49 OVERHEAT CUT-OFF THERMOSTAT
- 50 CENTRAL HEATING LIMIT THERMOSTAT
- 63 C.H. BOILER THERMOSTAT
- 133 PUMP OVERRUN THERMOSTAT
- 82 IONISATION ELECTRODE
- 83 FULL SEQUENCE AUTOMATIC CONTROL
- 51 CENTRAL HEATING FROST THERMOSTAT
- 129 RESET KNOB WITH LAMP
- 98 MAIN SWITCH
- 62 EXTERNAL CONTROL

NOTE: DOTTED LINES INDICATE CONNECTIONS TO BE PERFORMED DURING INSTALLATION





**Should you require help with any difficulties  
call our Technical Service Helpline on  
08707 282 885**

**Phone numbers:**

**Installer** \_\_\_\_\_

**Service Engineer** \_\_\_\_\_

**BECAUSE OF OUR CONSTANT ENDEAVOUR FOR IMPROVEMENT DETAILS  
MAY VARY SLIGHTLY FROM THOSE QUOTED IN THESE INSTRUCTIONS.**



**ALL SPECIFICATIONS SUBJECT TO CHANGE**

**Please note** - to avoid incurring unnecessary expense, in the event of a boiler shut down, check this is not caused by lack of electricity supply, gas supply or low water pressure before calling our Customer Service Helpline.

**Lichfield Road, Branston Industrial Estate, Burton Upon Trent, Staffordshire DE14 3HD  
Tel. 08707 282 885 - Fax 08707 282 886**