

INSTALLATION & USER INSTRUCTIONS

WALL MOUNTED LED ELECTRIC FIRE



MODELS COVERED BY THESE INSTRUCTIONS

EVOKE LED ELECTRIC

Focal Point Fires plc.
Christchurch, Dorset BH23 2BT
Tel: 01202 499330
Fax: 01202 499326
www.focalpointfires.co.uk
e : sales@focalpointfires.co.uk



Figure 1 : Evoke

Questions or problems with your appliance?
Don't take it back to the store

just give us a call on **01202 588601** we're here to help
lines open between 9am and 5pm, Monday to Friday

3 YEAR GUARANTEE

SUBJECT TO TERMS & CONDITIONS

For details please see: www.focalpointfires.co.uk/terms or telephone
01202 588635 Option 7

Please note : Except where otherwise stated, all rights, including copyright in the text, images and layout of this booklet is owned by Focal Point Fires plc. You are not permitted to copy or adapt any of the content without the prior written permission of Focal Point Fires plc.

All instructions must be handed to the user for safekeeping.

Revision C - 06/14

Section	Contents	Page No.	Section	Contents	Page No.
1.0	Preliminary Notes	2	8.0	Fixing the Appliance	3
2.0	Appliance Data	2	9.0	Operating the Appliance	4
3.0	Electrical Installation Requirements	2	10.0	Safety Cut-Out System	5
4.0	Site Requirements	2	11.0	Cleaning and Maintenance	6
5.0	Clearances to Combustible Materials	3	12.0	Servicing	6
6.0	Unpacking the Appliance	3	13.0	Appliance Dimensions	6
7.0	Component Checklist	3	14.0	Guarantee - Terms and Conditions	7

1.0 PRELIMINARY NOTES

The Evoke Electric Wall Heater provides convected heating in conjunction with an LED screen which can display a number of different fuel effects and scenes. The appliance is designed for indoor use, and can be simply wall mounted in the majority of wall positions anticipated. It can be located in any household room, with the exception of bathrooms. Read all of the instructions before commencing installation. Retain for future reference and pass on as necessary to subsequent owners of the appliance.

- **DO NOT** use this appliance immediately below a fixed socket outlet.
- **DO NOT** use this appliance in the immediate vicinity of a bath, shower, swimming pool or other area where water/moisture could present a hazard.

• **CAUTION:** This appliance must not be used in conjunction with any timer, programmer or thermal control, or any other device that will switch on the appliance automatically, as a fire risk may occur if the heaters are accidentally covered or displaced.

• **CAUTION:** Some parts of this product can become very hot and cause burns. Particular attention has to be given where children and vulnerable people are present.

• **WARNING:** Children of less than 3 years should be kept away unless continuously supervised. Children aged from 3 years and less than 8 years shall only switch on/off the appliance provided that it has been placed or installed in its intended normal operating position and they have been given supervision or instruction concerning use of the appliance in a safe way and understand the hazards involved. Children aged from 3 years and less than 8 years shall not plug in, regulate and clean the appliance or perform user maintenance.

• **WARNING:** This heater is not equipped with a device to control the room temperature. Do not use this heater in small rooms when they are occupied by persons not capable of leaving the room on their own, unless constant supervision is provided.

Do not allow the heater to be covered as this may cause overheating. The appliance must not be placed near curtains or similar material. A clearance space of at least 500mm should be allowed in front of the appliance.

The electrical socket that the appliance uses **MUST** be easily accessible. Do not route the supply cord directly over or above the heater unit. If the cord is damaged, it must be replaced by a service agent or competent person.

This appliance is not intended for use by persons (including children) with reduced physical, sensory or mental capabilities, or lack of experience and knowledge, unless they have been given supervision or instruction concerning use of the appliance by a person responsible for their safety. Children should be supervised to ensure that they do not play with the appliance.

The LED displays are produced by highly accurate technology, however, black pixels may be found, or red, blue and green pixels may not disappear. This is perfectly normal and within product specification. This should not be regarded as a fault.

2.0 APPLIANCE DATA

Weight (kg):	10.0 kg
Dimensions (mm):	H 480 x W 800 x D 154
Voltage (Volts):	230-240V a.c. 50Hz
Heating Elements:	2 x 900/1000 Watts
Supply Cord:	2 metres
Supply Plug:	BS 1363, 13A Fused
Location:	Indoor Use
LED Display:	40 Watts

3.0 ELECTRICAL INSTALLATION REQUIREMENTS

The appliance is designed to be wall mounted using the wall mounting plate and fixings provided.

DO NOT RECESS ANY PART OF THE APPLIANCE.

The appliance is supplied with a pre-wired three pin BS1363 plug (13 Amp fuse rated), and 2 metre cable. A standard switched outlet/wall socket, (including earth provision), must therefore be located within this distance, and be easily accessible in order to isolate the supply for maintenance and cleaning. This socket **must not** be mounted behind or above the appliance.

IMPORTANT: THIS APPLIANCE MUST BE EARTHED.

4.0 SITE REQUIREMENTS

The appliance is designed to be wall mounted via the wall mounting plate and fixings provided. The wall should be relatively flat and not interfere with any of the ventilation slots in the appliance casing.

The wall must be structurally sound and of a material capable of withstanding moderate heat. Finished plaster, conventional wallpaper, dry-lined plaster board are examples of suitable materials. Materials such as "flock" blown vinyl, embossed paper and cloth wall coverings which are sensitive to even small amounts of heat should be avoided, as some discolouration may occur. It should be noted that the appliance creates warm convected air currents. These currents move heat from the room surroundings to, and up the wall surfaces adjacent to the heater.

Installing the heater next to these types of wall coverings or operating the heater where impurities in the air, (such as tobacco smoke) exist,

4.0 SITE REQUIREMENTS - CONTINUED

GB IE

may slightly discolour wall finishing.

If the appliance is to be mounted on a dry lined or timber framed construction then the integrity and ability of the wall to carry the weight of the appliance must be confirmed. It is important in these circumstances that any vapour barrier and/or structural members of the house frame are not damaged. If you are unsure of the ability of the wall to carry the weight and/or which type of wall fixing to use, you should take professional advice and obtain the correct fixings. Alternatively, find a more suitable wall location.

- DO NOT**
- mount on a ceiling or floor.
 - recess any part of the appliance into the wall.
 - site any electrical equipment e.g. plasma screen TV sets etc, on the wall above the appliance.
 - site in a position where curtains or drapes could cover the appliance.
 - site in a position where other soft materials could cover e.g. below a coat rack.
 - site behind an opening door where mechanical impact/damage could occur.
 - site where the supply cable would become a trip hazard.
 - sit, stand or forcefully pull on the appliance.
 - obstruct, cover or force items into the openings.
 - use the heater to dry clothes.
 - site/use in an outdoor location(s).
 - run the supply cable under carpets.

5.0 CLEARANCES TO COMBUSTIBLE MATERIALS

It is important that the following clearances are maintained from the appliance to combustible materials and are dependant on the desired mounting location as defined below.

This appliance is designed to be wall mounted only. Do not stand it on the floor.

The minimum distance from the top of the appliance to a ceiling is 500mm.

The minimum distance to the sides of the appliance is 100mm.

The minimum distance to the front of the appliance is 500mm.

The appliance must not be mounted at floor level. Allow clearance to of 100mm to the floor.

A shelf may be mounted above the appliance provided it meets the requirements for shelves as detailed below.

Shelf Depth	Minimum Shelf Distance (measured from top of appliance)
2" or (50mm)	11.5" or (290mm)
6" or (152mm)	15.4" or (390mm)

6.0 UNPACKING THE APPLIANCE

Caution: This appliance is heavy. Always seek assistance whilst unpacking and/or during installation. Read *all* the instructions before continuing to unpack or install this appliance. Carefully remove the appliance from its packaging and lay on the floor with its back surface downward. Check that the remaining packaging contents correlate with the component checklist below. Please dispose of all packaging with care at your local recycling centre.

7.0 COMPONENT CHECKLIST

QUANTITY	DESCRIPTION
1	Heater unit including LED display
1	Decorative glass facia
1	Remote control handset
1	Wall mounting plate
1	Mains supply cord
1	Instruction Booklet
4	37mm long round head screws
4	Wall plugs

8.0 FIXING THE APPLIANCE

DO NOT connect the appliance to the supply at this stage. Remove the single thumbscrew from the middle of the base panel of the appliance, then remove the wall mounting plate from the appliance. After having selected the final mounting position of the appliance, taking into account the requirements as specified in sections 3.0, 4.0 and 5.0 of these instructions, the integrity of the wall, and the feasibility of the proposed supply cord routing, the wall mounting plate may be secured to the wall. To ensure safety, be sure to design the installation so that the strength of both the wall and any wall fixings used are sufficient.

Focal Point Fires plc. assumes absolutely no responsibility for injuries and damages that may occur due to improper installation or handling. The appliance should not be installed until all wet plastering and/or dry wall sanding and wall painting has been completed. Do not block the ventilation holes of the appliance. The wall onto which the appliance is installed must be flat. Install only on a vertical surface. Avoid sloped

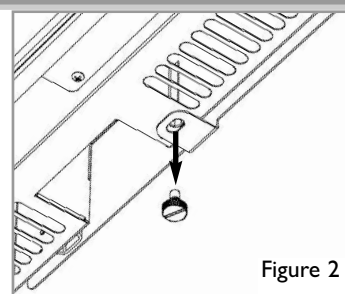

Figure 2

surfaces. Installation onto anything other than a vertical wall may result in fire, damage or injury.

If the appliance is to be mounted on the inner leaf of a conventional cavity brick wall, or a solid wall, then the wall plugs and fixing screws provided may be used. Depending on the condition of the wall it may be necessary to use additional fixings. In this situation, any additional fixings and wallplugs should be of the same size and type as the ones provided. Using a spirit level to check correct horizontal alignment, hold the wall mounting plate in the desired position and using a pencil, mark out the position of the fixing holes on the wall. Remove the mounting plate from the wall and drill four holes using only a 8.0mm masonry bit to a depth of 43mm. Insert the wallplugs provided ensuring they are flush to the wall. Using the screws provided, fix the mounting plate to the wall.

⚠ WARNING

The wall where the appliance is to be installed must be capable of long-term support of the total load of the appliance. Measures should also be taken to ensure sufficient strength to withstand the force of earthquakes, vibration and other external forces.

Figure 3

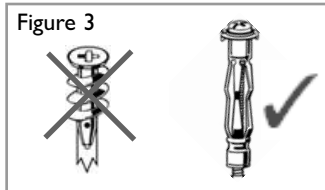

⚠ WARNING

Plasterboard alone is not considered to be a structural material. It is not recommended to rely on plasterboard fixings alone to support the weight of the appliance.

wooden studs, or supporting wooden members of the wall using two of the fixing screws provided. If this is not achievable then the wall should be strengthened using appropriate building materials.

If there is no alternative than to rely on some plasterboard fixings then special cavity screw fixings or hollow wall anchors will be required which are not supplied with this product. These should be constructed from metal and not plastic and of the design indicated in figure 3.

With the wall plate secured in position the heater unit can be hung onto the wall plate. Ensure the two hooks at the top of the wall plate fully engage the keyhole

efforts should be made to fix in at least two positions vertically, into one of the

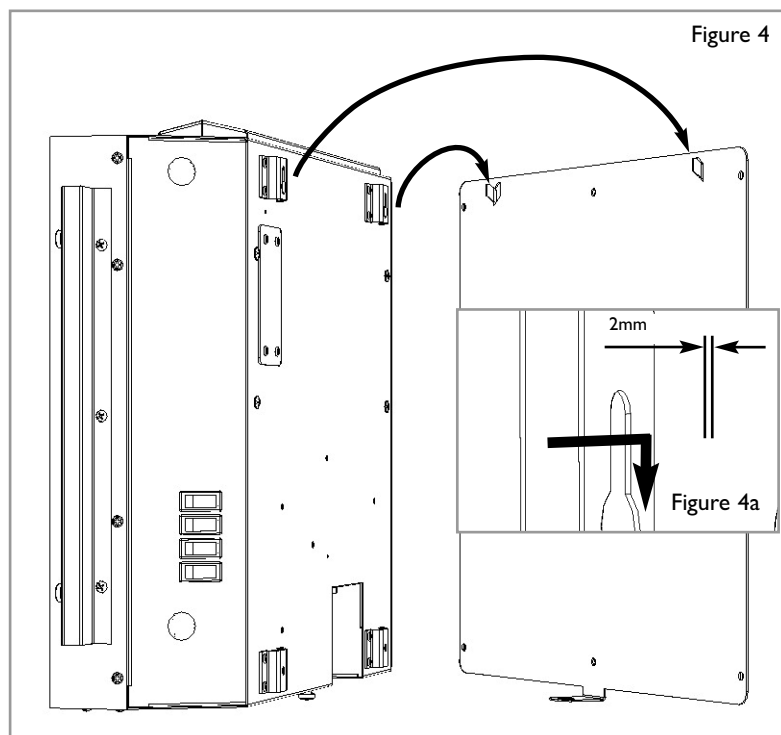

shaped holes in the brackets at the top of the heater back panel as shown in figure 4.

⚠ IMPORTANT

Ensure the frame is fitted correctly and the remote control infrared sensor can be seen through the hole in the middle of the lower glass panel. If not, appliance will not receive signals from the handset.

Finally re-fit the thumbscrew to the base panel of the heater via the tab at the bottom of the wall plate (see figure 2). This fixes the heater to the wall plate and will prevent the heater from falling off the wall in the event it is accidentally knocked, for example.

When the heater unit is in position on the wall, remove the decorative glass facia from the packaging and fit to the heater. The four keyhole shaped holes on the back of the frame mount directly onto the four M6 screws on the front of the heater (see figure 4a inset).

9.0 OPERATING THE APPLIANCE

Read All Instructions Before Use

Check that the heater outlet grille, mounted at the top of the appliance, is not covered or obstructed in any way, and ensure the power to the fire is switched on. The power to the LED display panel and the heater functions are controlled using four switches mounted on the lower right hand side panel.

Controlling the heater functions

The first switch towards the top, marked **(OI)**, controls the main power to the appliance and switches on the LED display panel. This feature can be used independently of the heating features.

The next switch down, marked **(*)** operates the fan blower without heat, and can be used for cool air circulation. However for this feature, the main power switch **(OI)**, must also be in the "on" position.

The next switch down, with a "single bar" marked **(I)** operates the low heat, (1kW), setting.

The switch at the bottom, with "two single bars" marked **(II)**, operates the high heat, (2kW) setting.

To operate the fire in any of the above modes, the top switch marked **(OI)** must be switched to the "on" position.

To operate the fire, the **(OI)** switch must be on, followed by the **(*)** switch to start the blower. To obtain heat from the appliance, the blower must be on and the **I** switch must then be operated for **LOW** heat, followed by the **II** switch for the **HIGH** heat setting.

Controlling the LED display panel

LED on/off control: The LED display may be switched on and off independently of the heater functions by using the LED on/off button as shown in figure 14.

Scene select buttons: The appliance is pre-programmed with nine different scenes as shown in figures 5 through 13. These scenes have been specially edited to run in a seamless loop. When the appliance is switched on, the log fire scene will automatically run. To select a different scene press the appropriate scene select button to choose the desired scene. During normal operation the footage may occasionally be seen to 'freeze' for a fraction of a second. This happens as the scene is recycled to loop again. This is perfectly normal and should be no cause for concern.

Volume up, down and mute button: Some of the LED scenes include sound effects. These buttons raise and lower the volume. The Mute button mutes the speakers. While the speakers are muted, a symbol will be displayed on screen. Press again to de-activate.

The appliance can be switched off at any time, irrespective of the particular mode selected, by simply switching the first switch marked (OI) to the "off" position. It is also recommended to unplug the power supply cable at the supply outlet when not in use.



Fig. 5 - Log fire



Fig. 6 - Twig fire



Fig. 7 - Coal fire

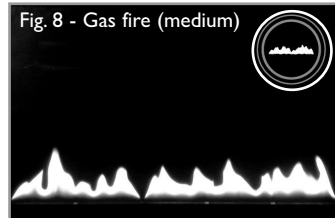

Fig. 8 - Gas fire (medium)

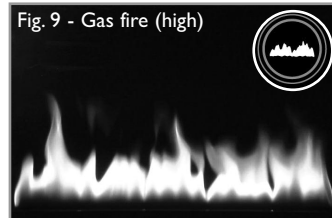

Fig. 9 - Gas fire (high)

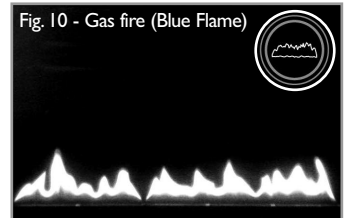

Fig. 10 - Gas fire (Blue Flame)

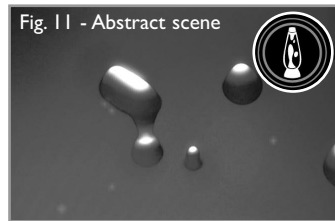

Fig. 11 - Abstract scene



Fig. 12 - Nature scene



Fig. 13 - Aquarium scene

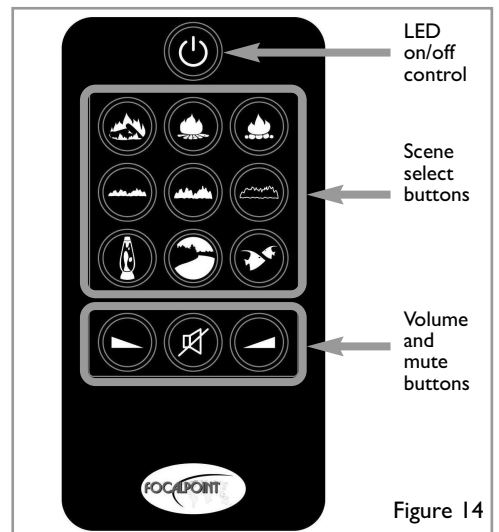

Figure 14

10.0 SAFETY CUT-OUT SYSTEM

This appliance has a safety cut-out system fitted which will activate if the air inlets or heater outlets are obstructed. For safety reasons the fire **WILL NOT** switch on again automatically.

NOTE: The LED display panel will remain operational if the cut-out is activated, only the fan heater elements are prevented from operating.

The following procedure must be carried out before the fire can be operated again:

1. Unplug the power supply cable **at the outlet socket and place all switches to off at the appliance.**
2. Leave the fire OFF for a period of not less than 10 minutes, ensuring any obstructions are removed.
3. Plug in the power supply cable **at the outlet socket, and then switch on at the appliance.**

If the appliance fails to operate correctly, repeat the above procedure. If the appliance still fails to operate properly, it may be necessary to clean the fan. If the fan has accumulated a build-up of dust, this can cause the safety cut-out system to operate. See section 11.0 for details.

If an attempt to switch on is made before the safety cut-out has reset, the heaters may cut-out for a further period of time. If the sequence has been followed correctly and the heaters still fail to function, check the power supply cable plug is plugged in at the outlet socket. If this is not the cause, call an electrician.

11.0 CLEANING AND MAINTENANCE

GB IE

ALWAYS DISCONNECT THE APPLIANCE AT THE SUPPLY OUTLET SOCKET BEFORE UNDERTAKING ANY CLEANING.

Except for periodic cleaning of dust, there are no specific requirements for care, other than regular cleaning of the general appliance. A wipe with a dry cloth is normally sufficient. **DO NOT** use abrasive cleaners as they can damage the finish. Make sure the heater outlet grille (located on the top panel), and the air inlet mesh grilles (located on the sides and base panel) are kept clear of dust, pet hair and other airborne household matter. These should be vacuum cleaned periodically using a brush attachment.

GLASS FACIA PANEL - This should only be cleaned using a suitable glass cleaner. Test on a small area first.

CLEANING THE FAN - Over time, a build-up of lint, dust and other airborne matter such as pet hair can accumulate on the fan. This can cause the safety cut-out system (see section 10.0) to operate. In order to clean the fan, disconnect the appliance at the supply outlet socket. Remove the decorative glass facia and remove the appliance from the wall, removal is the reverse of fitting as described in section. 8.0.

Using a pozidrive PZ2 screwdriver, remove the four screws shown in figure 15 from the back of the appliance and remove the fan cover to access the fan rotor. Using a clean, dry soft brush very gently remove any build-up of dust from the fan blades, cleaning the inside of the blades as well as the outside. Use a vacuum cleaner nozzle to collect the dust.

IMPORTANT : THE FAN IS A VERY DELICATE COMPONENT AND GREAT CARE SHOULD BE TAKEN NOT TO DAMAGE THE FAN BLADES. DO NOT TOUCH THE FAN BLADES EXCEPT WITH THE BRUSH.

Re-assemble the appliance and fit back on the wall.

IMPORTANT : DO NOT OPERATE THE HEATER WITHOUT THE FAN COVER FITTED.

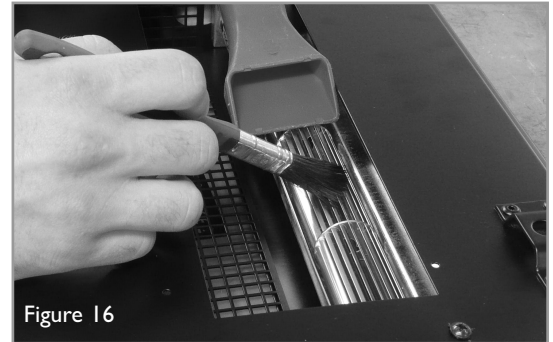
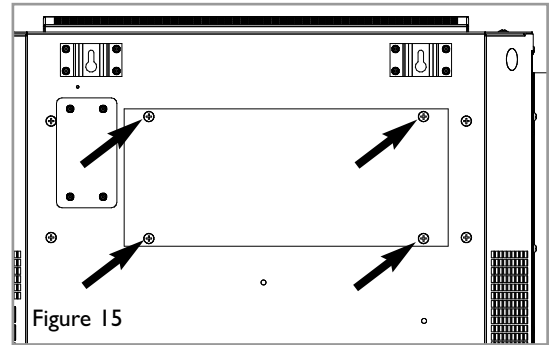

12.0 SERVICING

Except the fan which can be cleaned (see section 11.0), there are no internal user serviceable parts.

Check regularly for security of wall fixings as appropriate. Also check security of supply cable and connections. If the supply cable becomes damaged, it must be discarded and replaced.

The wires in the cable are coloured in accordance with the following code:

LIVE	- Brown
NEUTRAL	- Blue
EARTH	- Green/Yellow

Refer to Section 2.0, Appliance Data for fuse specification. Excluding fuses, use only genuine manufacturers spare parts available from your supplier.

13.0 APPLIANCE DIMENSIONS

Figure 17

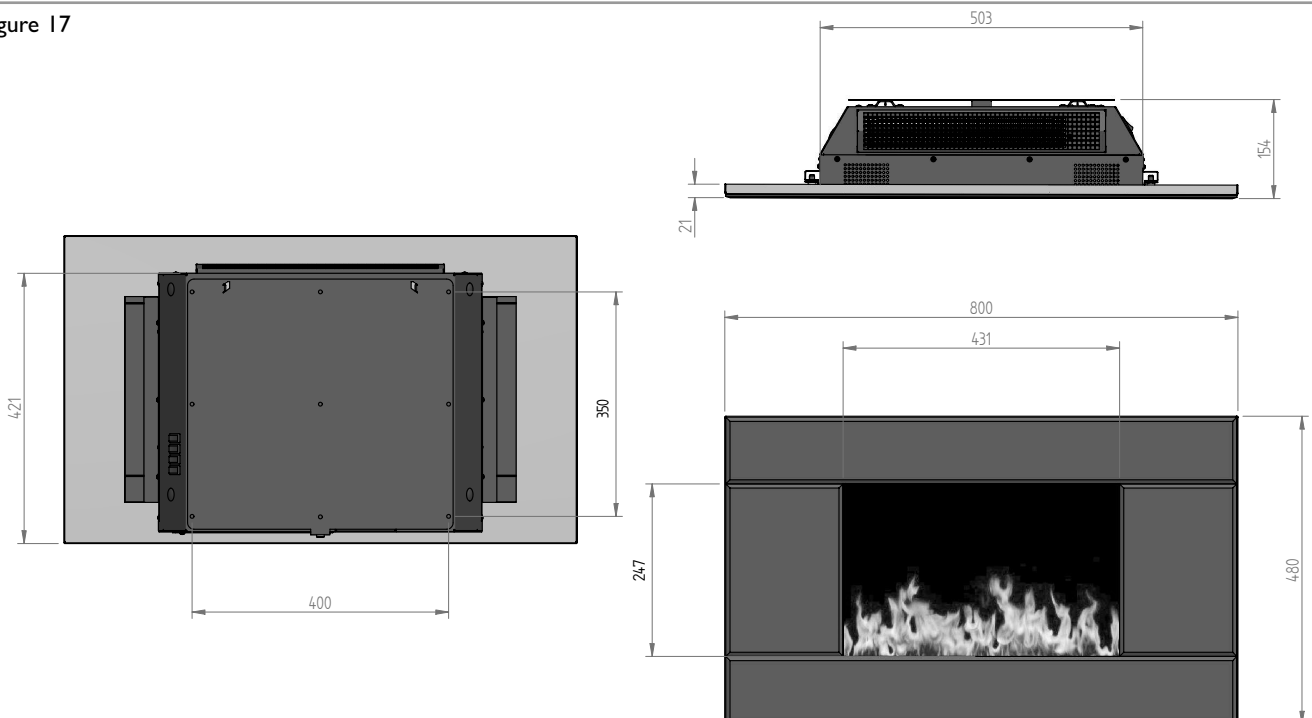

The 3 year guarantee only covers products purchased on or after 1st February 2009. For all gas fires purchased the 3 year guarantee commences from the date of purchase, provided that the following 3 terms and conditions are adhered to:

Registration is not required.

1. For any claim to be made within the 3 years from date of purchase you will be required to provide and supply us with your proof of purchase.
2. Your gas fire must have been commissioned by a CORGI/Gas Safe* registered installer, evidence of which you must provide together with the CORGI/Gas Safe* registration number.
3. Your appliance must have been serviced annually, irrespective of use, by a CORGI/Gas Safe* registered installer, evidence of which must be provided, such as the receipt.

Please note all consumable items such as any ceramics including: coals, pebbles, the matrix, front strips, side cheeks, rear panels and tapered rear panels are not covered by the 3 year guarantee. For all Electric fires purchased the 3 year guarantee commences from the date of purchase, providing that you can supply the proof of purchase. This does not cover consumable items such as pebbles, coals or light bulbs.

Making a claim is easy.

If you wish to make a claim under our 3 year guarantee and all the terms and conditions for your product have been met then please submit the following information for the attention of the 3G Service Department to the address below. Alternatively, you can email or fax. Please note that this does not affect your statutory rights.

Focal Point Fires Plc, 3G Service Department, Reid Street, Christchurch, Dorset, BH23 2BT.
Alternatively email: 3g@focalpointfires.co.uk or fax. 01202 499326.

Details required:

1. Name, full address including post code and contact telephone number.
2. Receipt of purchase or credit card statement.
3. Original installers CORGI/Gas Safe* registration number and date of installation (gas fires only).
4. Annual service receipt for every 12 months (gas fires only).

*Gas Safe Register replaced CORGI as the gas registration body in Great Britain and the Isle of Man on 1st April 2009.



Waste electrical products should not be disposed of with household waste. Please recycle where facilities exist. Check with your local authority or retailer for recycling advice.

As our policy is one of continuous improvement and development, we therefore hope that you will understand we must retain the right to amend details and/or specifications without prior notice.