

Wall hung, fan flue, room sealed gas boiler

GAIA

Service manual

Leave this manual adjacent to the gas meter

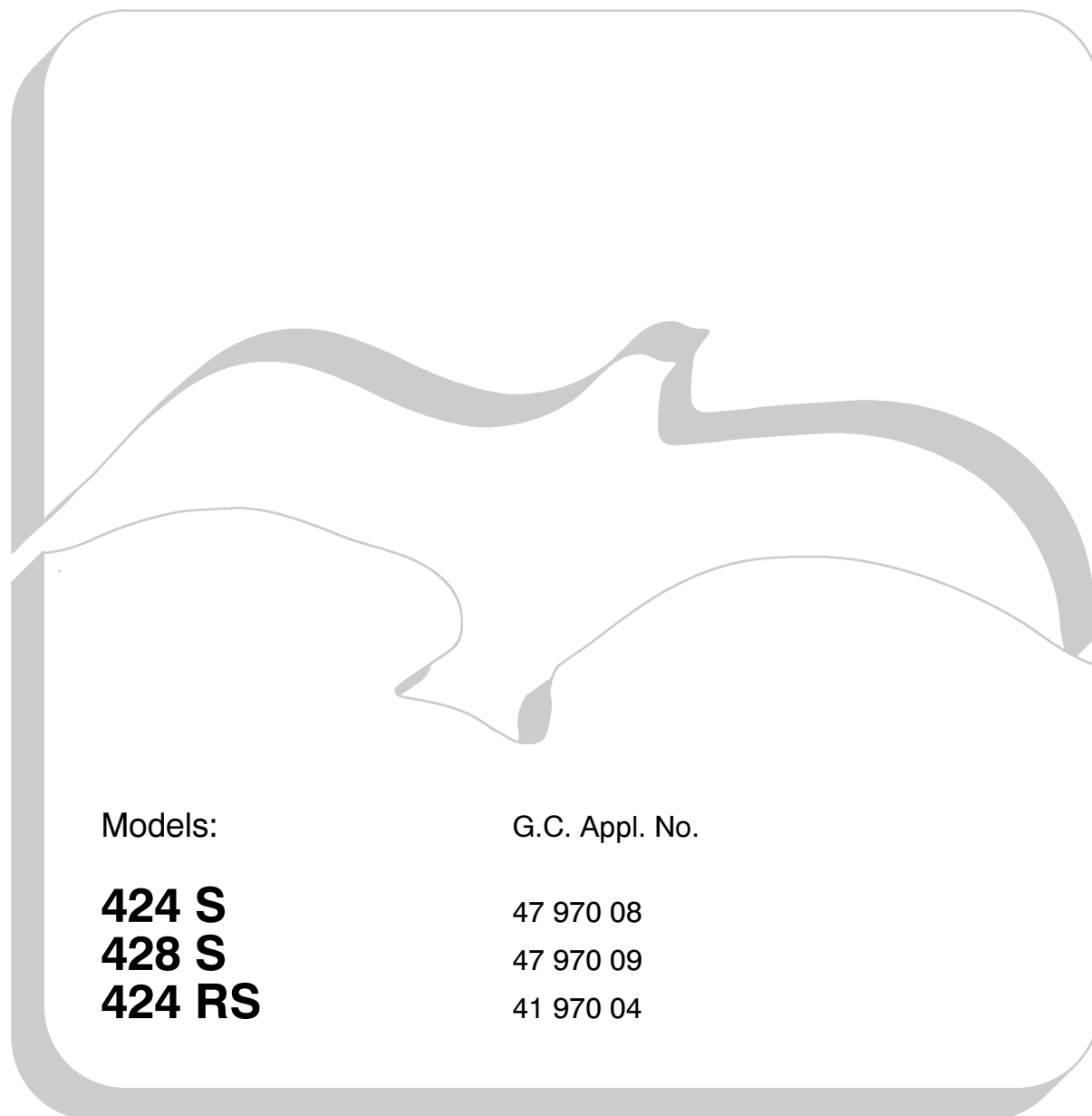

Models:

G.C. Appl. No.

424 S

47 970 08

428 S

47 970 09

424 RS

41 970 04

Table of contents

1 Overall information	1	11 Full sequence ignition device	23
1.1 Overall View	1	11.1 Function	23
1.2 Hydraulic diagram	1	11.2 Checks	23
2 General access and emptying hydr. circuits	2	11.3 Removal	23
2.1 Nomenclature	2	11.4 Ignition sequence	24
2.2 Body panels	2	12 Gas valve	25
2.3 Access to the electric parts of the control panel	3	12.1 Function	25
2.4 Access to the sealed chamber	3	12.2 Nomenclature of the parts	25
2.5 Emptying the main circuit	3	12.3 Adjustment	25
2.6 Emptying the d.h.w. circuit	3	12.4 Checks	25
3 Diagrams	4	12.5 Removal	26
3.1 Wiring diagram	4	13 Main circuit flow switch	27
3.2 Functional flow diagrams	5	13.1 Function	27
3.3 Control circuit voltages	7	13.2 Checks	27
4 Fault finding	8	13.3 Removal	28
5 Main heat exchanger	11	14 D.h.w. filter and flow limiter	29
5.1 Characteristics	11	14.1 General notes	29
5.2 Removal	11	14.2 Removal of the filter	29
5.3 Cleaning	11	14.3 Flow limiter	29
6 D.h.w. heat exchanger	12	15 Temperature probes	30
6.1 Function	12	15.1 Function	30
6.2 Removal	12	15.2 Checks	30
7 Pump	13	15.3 Removal	31
7.1 Function	13	16 By-pass valve	32
7.2 Checks	13	16.1 Function	32
7.3 Removal	13	16.2 Removal	32
8 Diverter valve and d.h.w. pressure switch	14	17 Water pressure switch and pump relè	33
8.1 Function	14	17.1 Function	33
8.2 Checks	14	17.2 Checks	33
8.3 Removal	14	17.3 Removal of the pressure switch	33
9 Electronic control circuit	17	17.4 Removal of the pump relè	33
9.1 Function	17	18 Flue fan, venturi, air pressure switch	34
9.2 Selection and adjustment devices	17	18.1 Function	34
9.3 Checking the temperature	17	18.2 Checks	34
9.4 Function selectors	18	18.3 Removal of the fan	35
9.5 Ignition gas pressure regulator	19	18.4 Removal of the air pressure switch	35
9.6 Max. c/h power regulator	19	19 Ignition and detection electrodes	36
9.7 Checks	19	19.1 Function	36
9.8 Removal of the control circuit	19	19.2 Checks	36
9.9 Thermal control in the "❄️" mode	21	19.3 Removal	36
9.10 Thermal control in the "❄️" mode	21	20 Safety thermostat	37
10 Display circuit	22	20.1 Function	37
10.1 Function	22	20.2 Checks	37
10.2 Display circuit operation	22	20.3 Removal	38
10.3 Removal	22	21 Short spare parts list	40

1 Overall information

1.1 Overall View

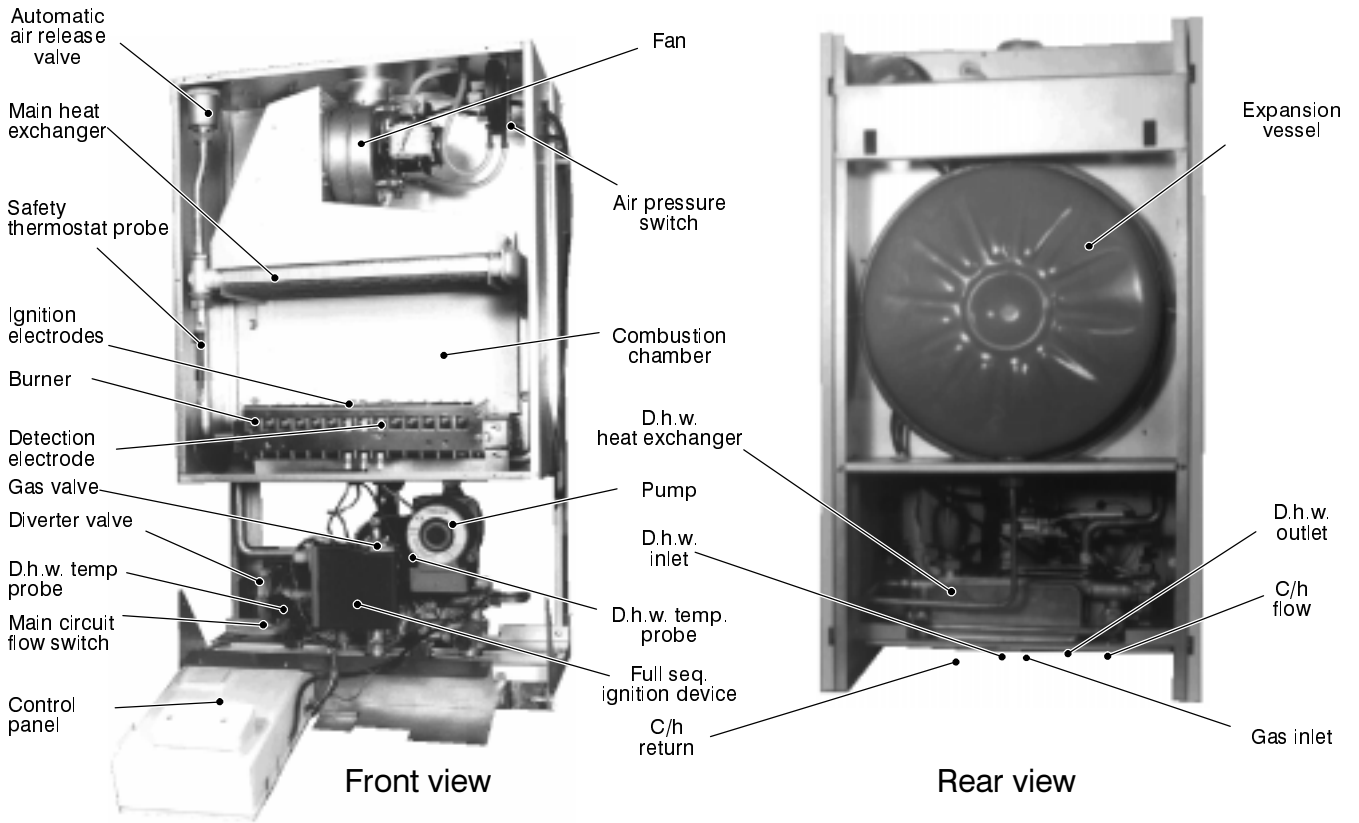

fig. 1

1.2 Hydraulic diagram

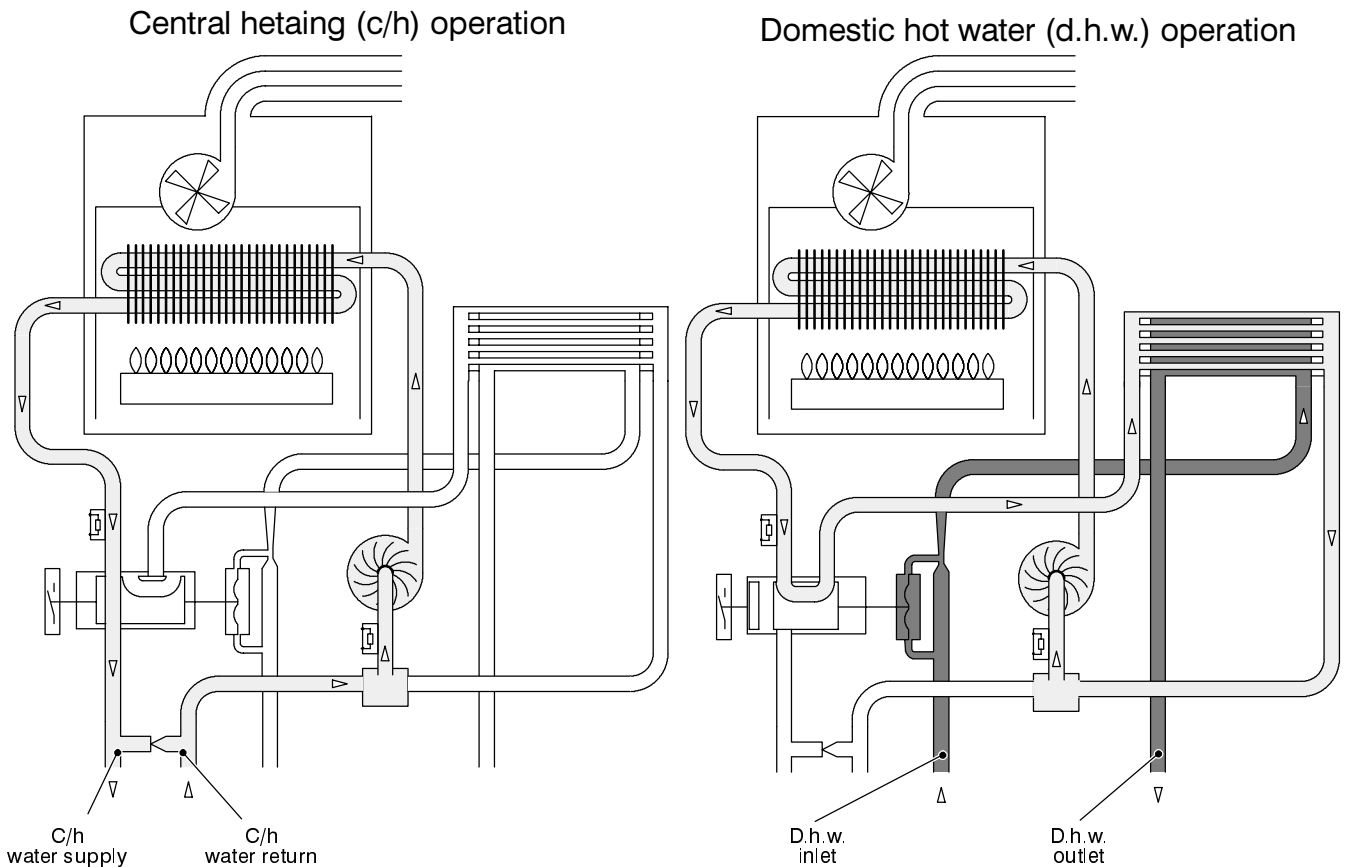

fig. 2

2 General access and emptying hydraulic circuits

2.1 Nomenclature

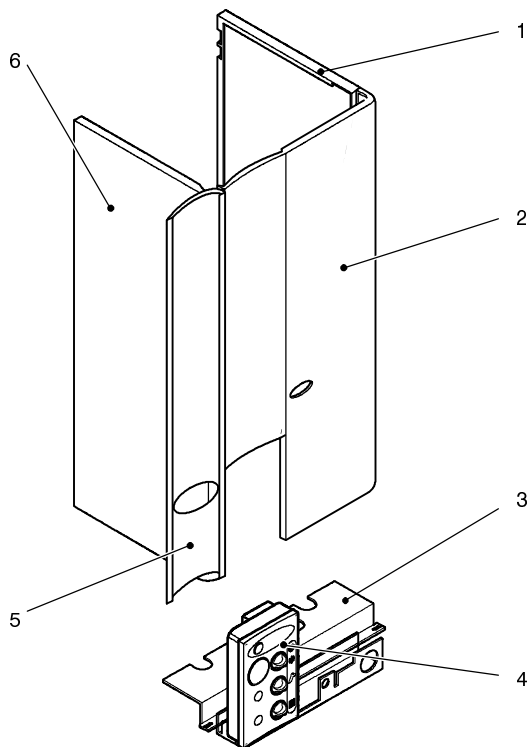

fig. 3

- 1 Right side panel
- 2 Front panel
- 3 Lower protection plate
- 4 Control panel
- 5 Case lid
- 6 Left side panel

2.2 Body panels

Warning: isolate the boiler from the mains electricity supply before removing any covering or component.

For the most part of the check and maintenance operations it is necessary to remove one or more panels of the case.

The side panels can be removed only after the removal of the front panel.

To remove the front panel remove the two screws A (fig. 4) and bring the base of the panel far from the boiler.

Lift the front panel freeing it from the hooks placed on its left and right side.

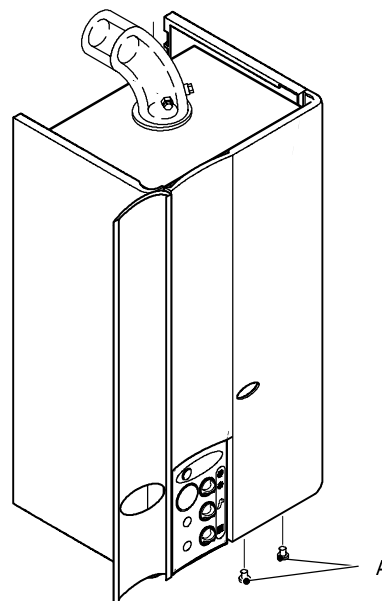

fig. 4

To remove the side panels loosen the screws B (fig. 5), bring the base of the panels far from the boiler and lift them, freeing them from the side hooks of the frame.

To remove the lower protection plate completely unscrew the screws B and remove the plate (fig. 5).

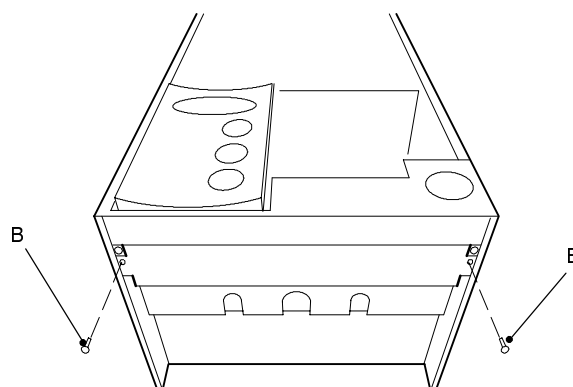

fig. 5

To gain access to the supply terminal block and to the parts located behind the control panel unscrew the screws C and lower the panel (fig. 6).

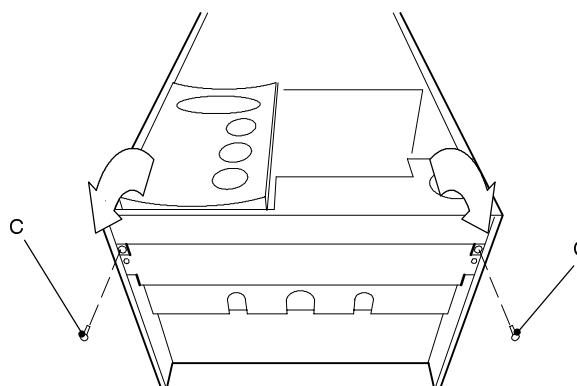

fig. 6

2.3 Access to the electric parts of the control panel

Warning: isolate the boiler from the mains electricity supply before removing any covering or component.

To gain access to the parts located inside the control panel remove the four screws *D* (fig. 7) and remove the cover pulling it towards the front.

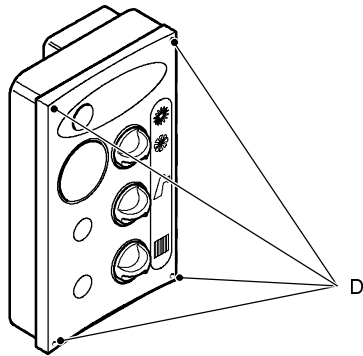

fig. 7

2.4 Access to the sealed chamber

To gain access to the parts contained in the sealed chamber it is necessary to remove the cover of the sealed chamber.

For this purpose, remove the front panel of the case and remove the screws *E* as indicated in fig. 8.

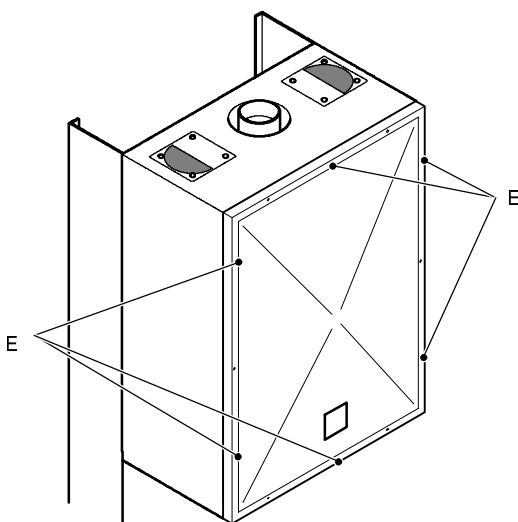

fig. 8

2.5 Emptying the main circuit

- 1 Close the c/h circuit isolation valves *F* (fig. 9).

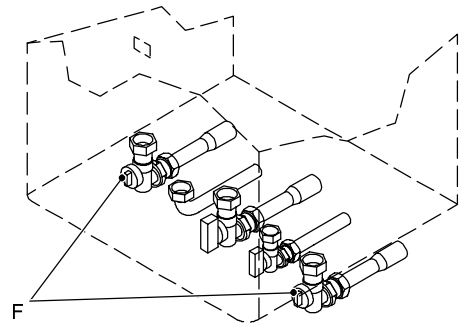

fig. 9

- 2 Open the draining tap *G* (fig. 10) until the boiler is completely emptied.

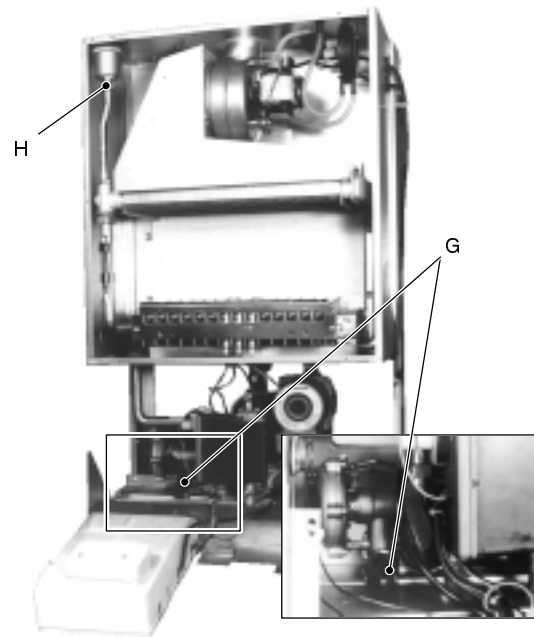

fig. 10

To facilitate the downflow of water, remove the front panel, also remove the sealed chamber cover and loosen the nut *H* (fig. 10) of the automatic air bleed valve.

Tight it again once the emptying has been completed.

2.6 Emptying the d.h.w. circuit

- 1 Close the d.h.w. circuit cut-off valve *I* (fig. 11);
- 2 Open one or more hot water taps of the plant until the boiler has been completely emptied.

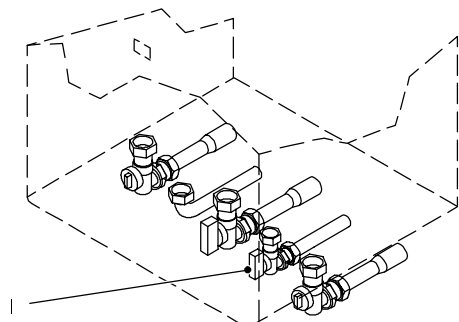
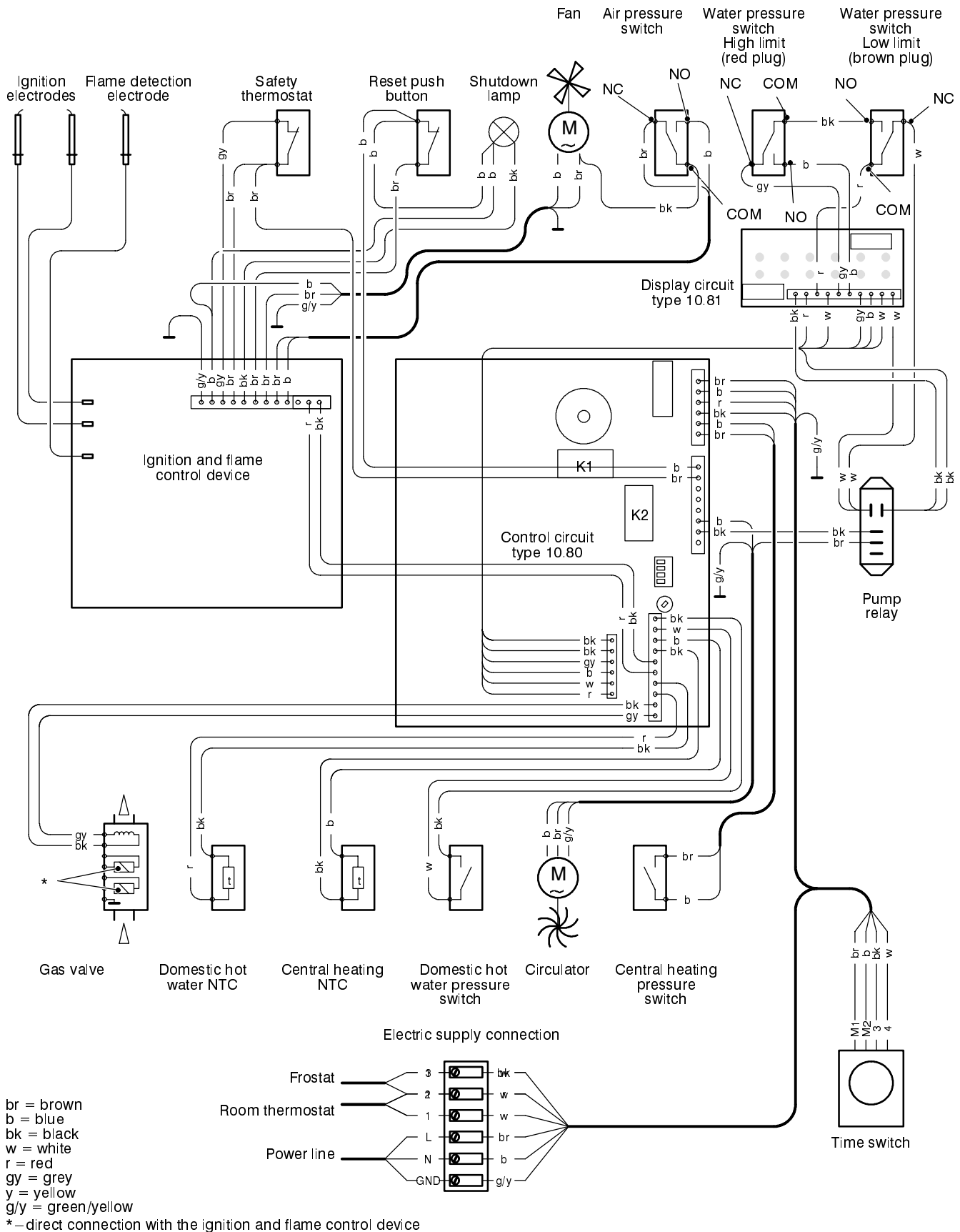

fig. 11

3 Diagrams

3.1 Wiring diagram



3.2 Functional flow diagrams

General layout
function switch position off

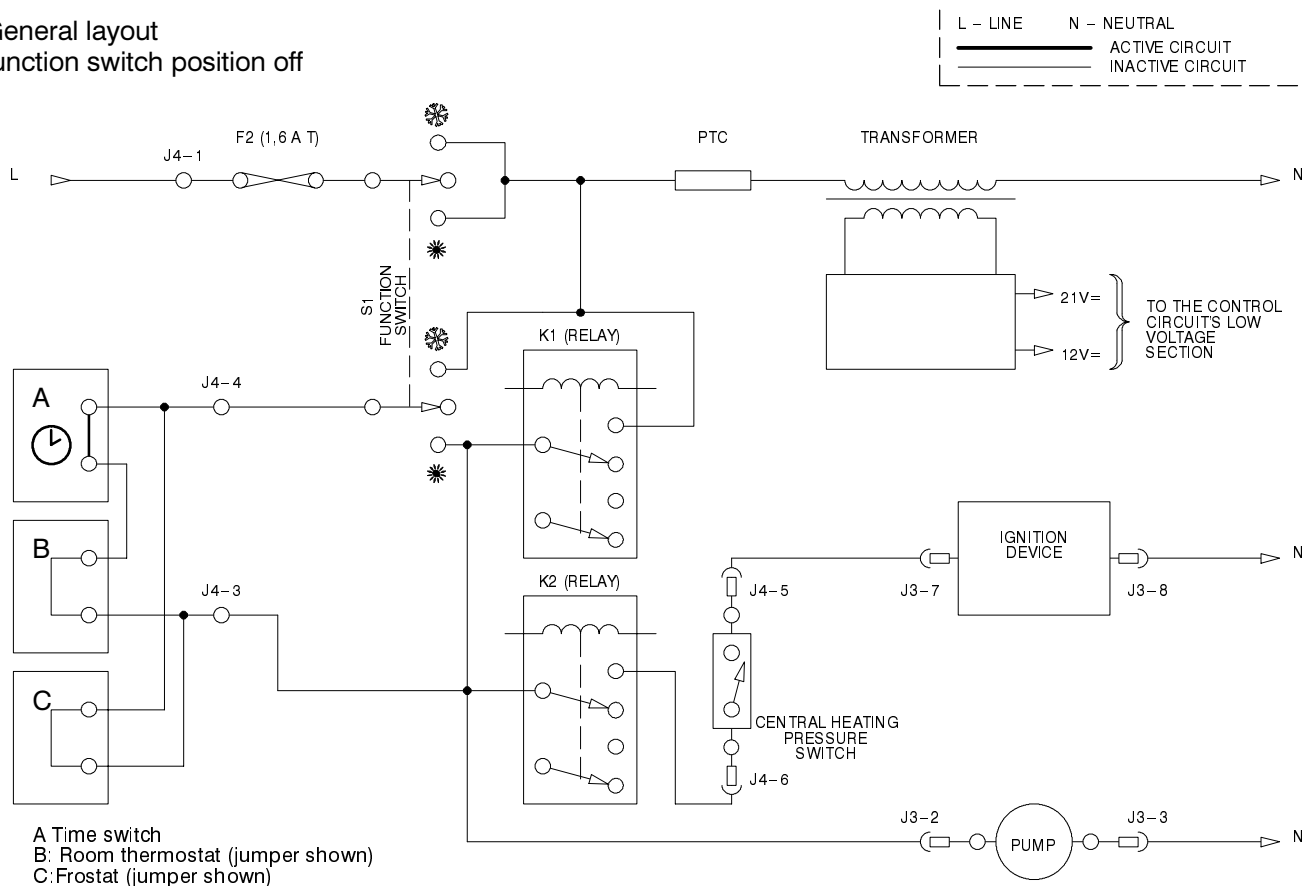

Function switch position Heat request on c/h

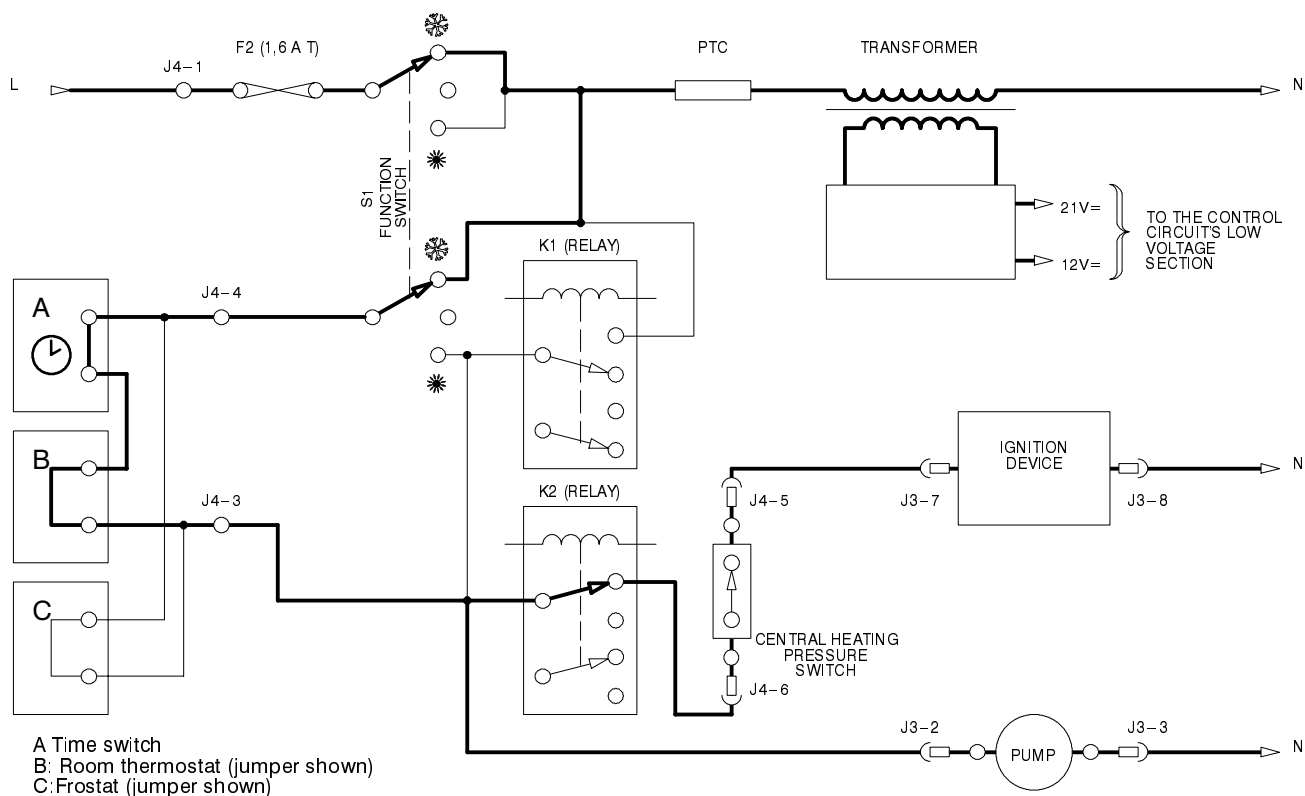

Diagrams

Function switch position ❄️
Heat request on d.h.w.

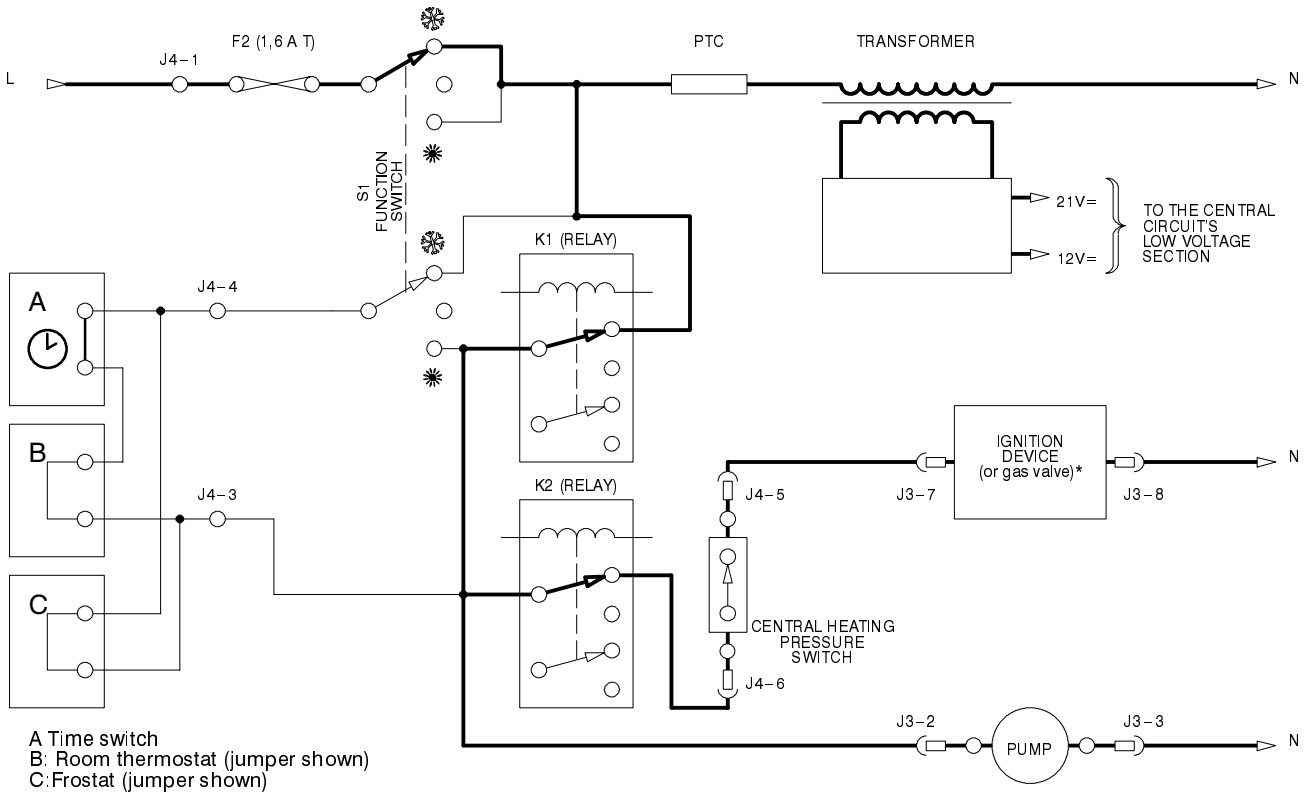
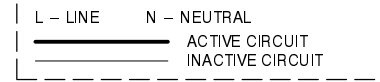

Function switch position *
Heat request on d.h.w.

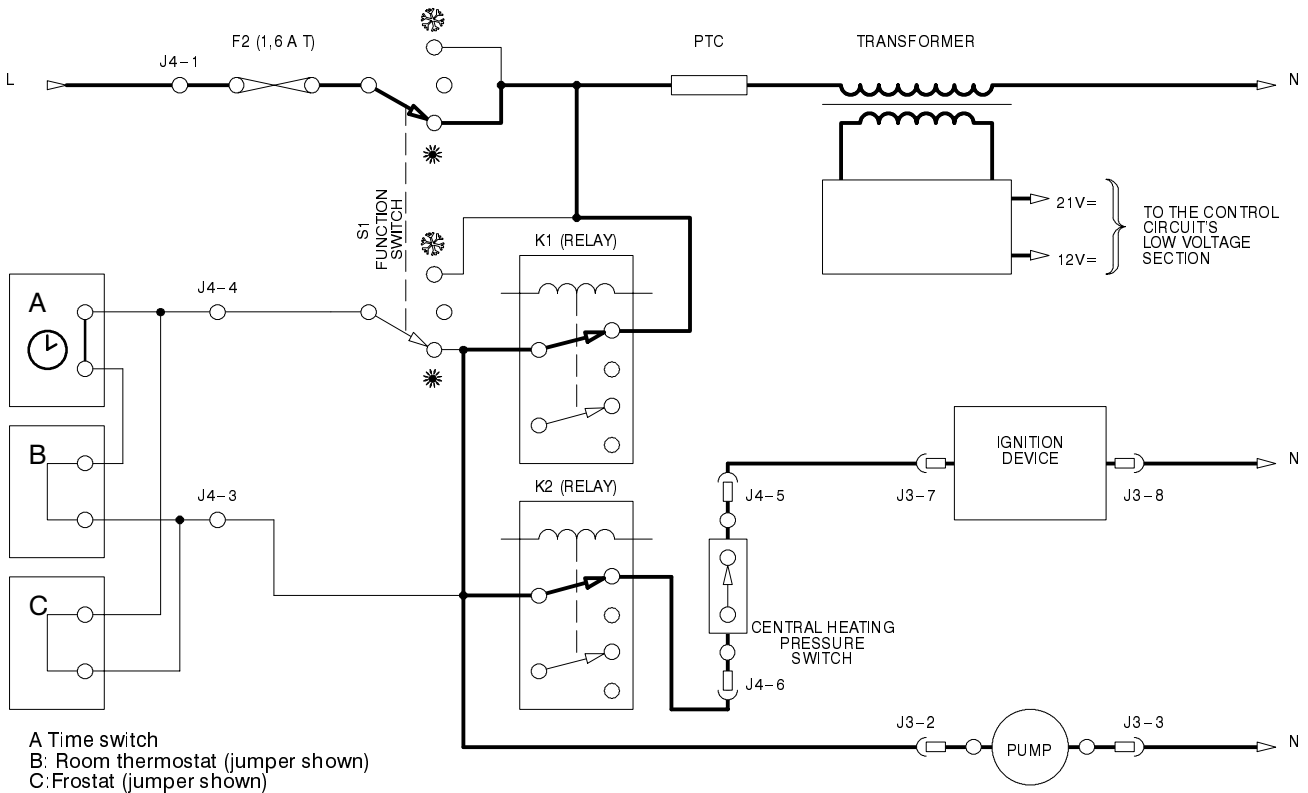

3.3 Control circuit voltages

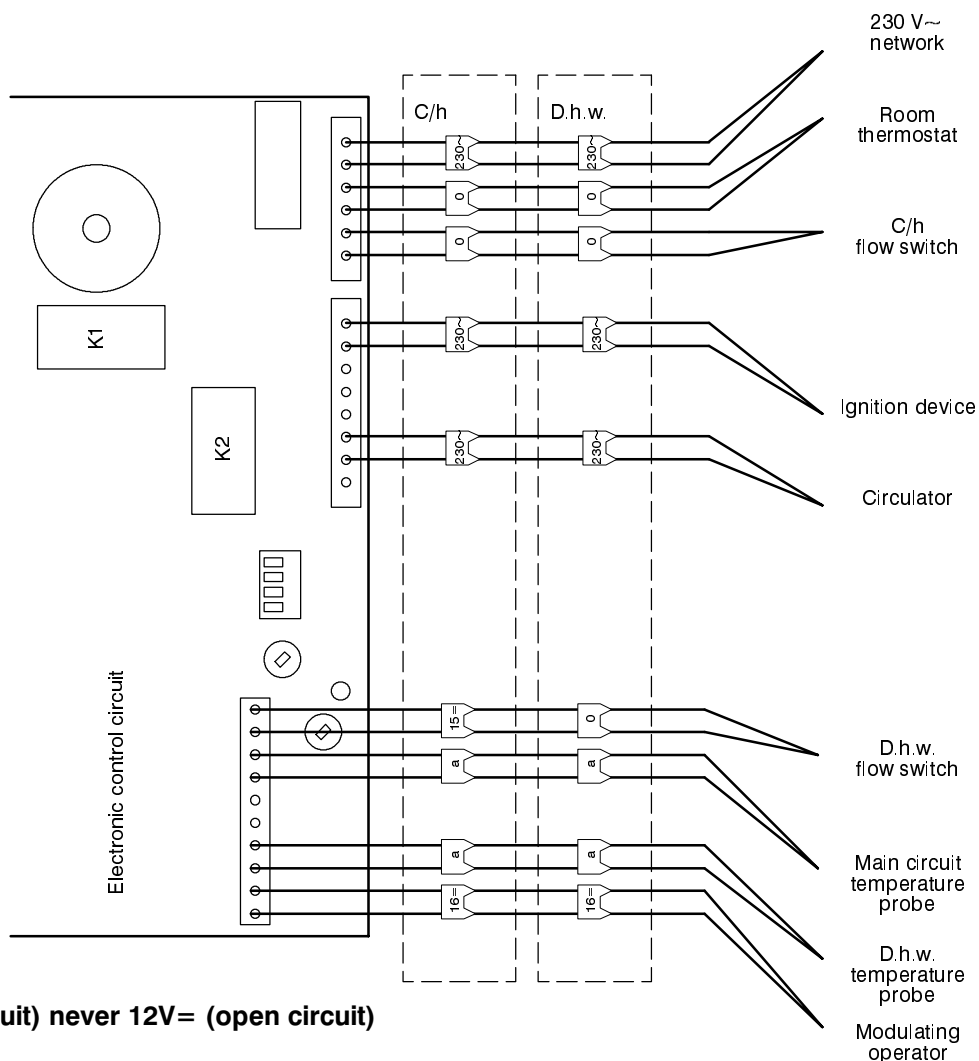

a: never zero (short circuit) never 12V= (open circuit)

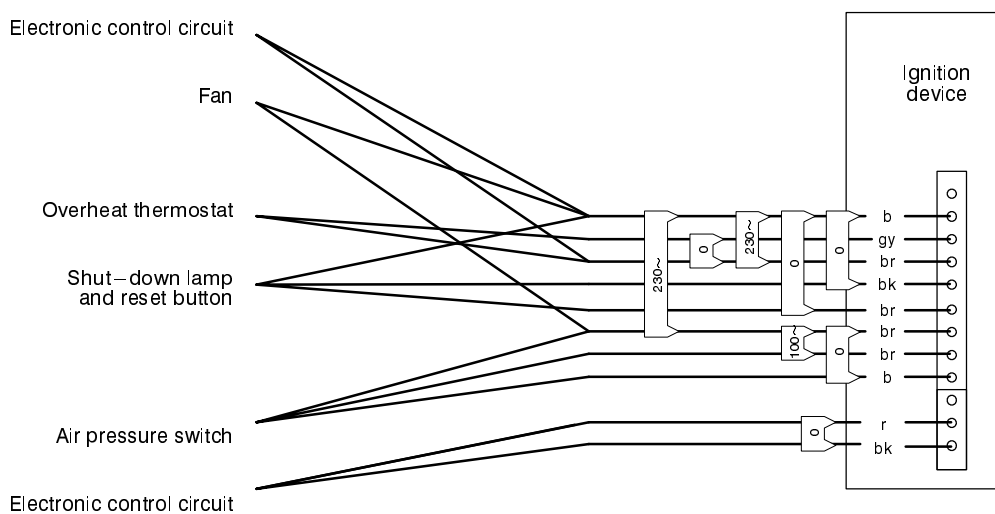

Electrical voltages in Volts during normal operation with burner on at maximum power

Section of the manual → (note ref. in brackets)	Components to check																						
	(1)	(2)	(3)	(4)	6	7.2	8.2	9.7	11.2	12.4	13.2	14.2	15.2	16	18.2	19.2	20.2	(7)	(8)	-	17		
Defect ↑																							
The boiler runs but the combustion is noisy and there is flame lift effect.			■																				
Incorrect modulation																							
The boiler switches on and off the burner to a fixed gas pressure																							
The boiler fires on c/h and d.h.w. for a few seconds, goes off and fires again constantly.			■			■																	
The fan turns but the boiler does not turn on.			■																				
The boiler turns off immediately, drawing d.h.w. Regular functioning in c/h																							
Noisy boiler			■																				
With the function switch in summer or winter mode the boiler turns on even without drawing the d.h.w. and the main circuit temperature is kept at about 90°C. The pump runs continuously. The c/h system does not heat. The boiler operates correctly in d.h.w. mode.																							
The boiler does not supply d.h.w. (cold water from the tap). Regular operation in c/h mode even during a drawing off d.h.w.																							
On c/h mode the temperature of the main circuit reaches 90°C and the c/h system does not heat. The boiler operates correctly on d.h.w. mode.																							

Section of the manual → (note ref. in brackets)	Components to check														17																			
	(1)	(2)	(3)	(4)	6	7.2	8.2			9.7			11.2	12.4		13.2	14.2	15.2	16	18.2	19.2	20.2	(7)	(8)	-									
Defect ↑	Power supply line	Gas supply line	Flue pipes	C.h. circuit	D.h.w. circuit	D.h.w. heat exchanger	Pump (windings)	Pump (rotor – impeller)	Diverter valve (membrane)	Diverter valve (deviation group)	D.h.w. pressure switch	Fuse (regulation p.c.b.)	Regulation p.c.b.	Function selectors (reg. p.c.b)	Full sequence device	Gas valve (on-off operators)	Gas valve (modulating operator)	Main circuit flow switch	D.h.w. filter	Main circuit temp. probe	D.h.w. temp. probe	By-pass valve	Fan and venturi device	Air pressure switch	Ignition electrode	Detection electrode	Safety thermostat	Injectors	Expansion vessel	Safety valve	Water pressure switch	Pump relay		
The boiler operates correctly but the gas pressure to the burner remains at minimum.						■						■				■																		
Poor d.h.w. temperature						■																												
Low flow rate of d.h.w.					■																													
Water leaks from the safety valve during operation on c/h				■																														
Water leaks from the safety valve when the boiler is off.																																		

Note

- Check for 220–240V~ between line (L) and neutral (N)
Verify the integrity of supply cable, plug and external fuses.
Check the polarity of line and neutral connection
- Verify the soundness of the gas supply pipe, the position of stop valves.
Check the gas pressure at the inlet test point of the gas valve (see sect. 12.3) with the boiler at rest and during operation
- and compare it with the values given on the installation booklet.
Check for soundness and absence of obstructions. Verify that the flue terminal is correctly installed (see clearances) and ensure that exhaust gas is not sucked back by the boiler.
Check for soundness of the circuit and verify its correct filling (see also installation manual).
A jammed by-pass could cause the over-heating of the main circuit and the intervention of the safety thermostat.
- Verify the soundness of the gas supply pipe, the position of stop valves.
Check the gas pressure at the inlet test point of the gas valve (see sect. 12.3) with the boiler at rest and during operation
- Check the **minimum** gas pressure at the outlet test point of the gas valve (see sect. 12.3) and compare it with the value given on the installation booklet.
- Verify the cleanliness of injectors.
- Check the pressurization of the expansion vessel. Refer to the installation manual for proper values.
- d.h.w. pressure too high or flow rate too high. If necessary insert a flow rate limiter (14.3).

5 Main heat exchanger

5.1 Characteristics

The main heat exchanger (A in fig. 12) has the function of transferring heat of the gas produced by combustion to the water circulating in it.

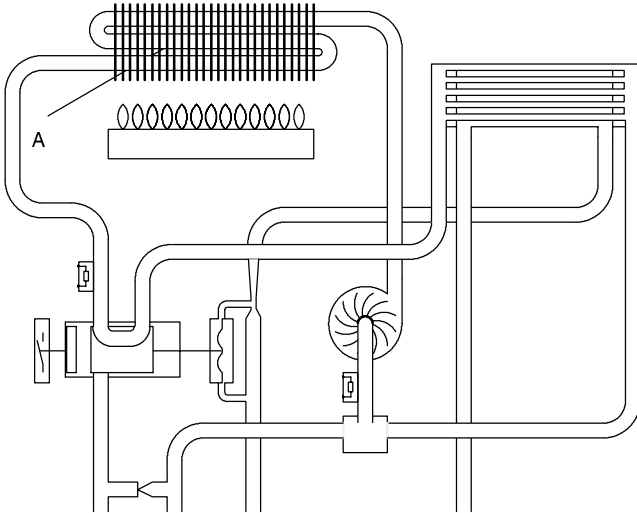

fig. 12

The hydraulic circuit consists of five elliptic pipes connected together in series (fig. 13).

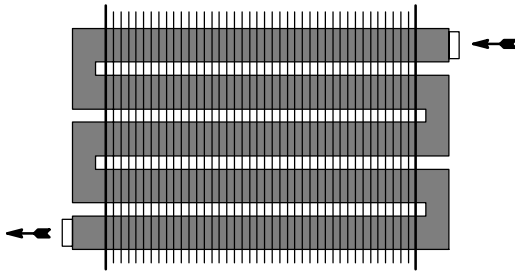

fig. 13

5.2 Removal

Warning: isolate the boiler from the mains electricity supply before removing any covering or component.

- 1 Empty the main circuit of the boiler
- 2 Remove the front panel of the case
- 3 Remove the sealed chamber cover.

For models 424 S, 424 RS...

- 4a Remove the cover of the combustion chamber;
- 5a Remove the front part of the flue gas hood by unscrewing the screw B (fig. 14a)

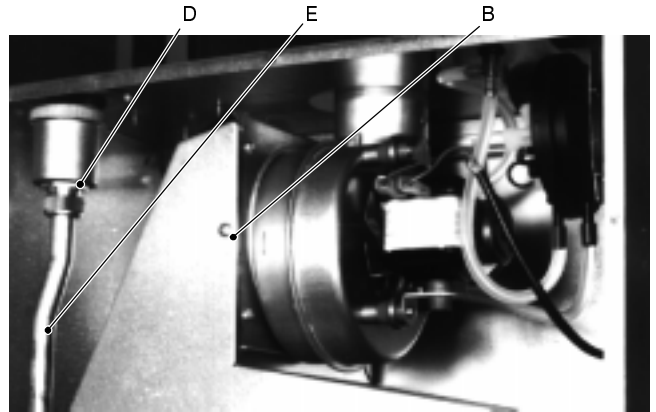

fig. 14a

For model 428 S...

- 4b Remove the front part of the flue gas hood by unscrewing the four screws C (fig. 14b)
- 5b Remove the cover of the combustion chamber

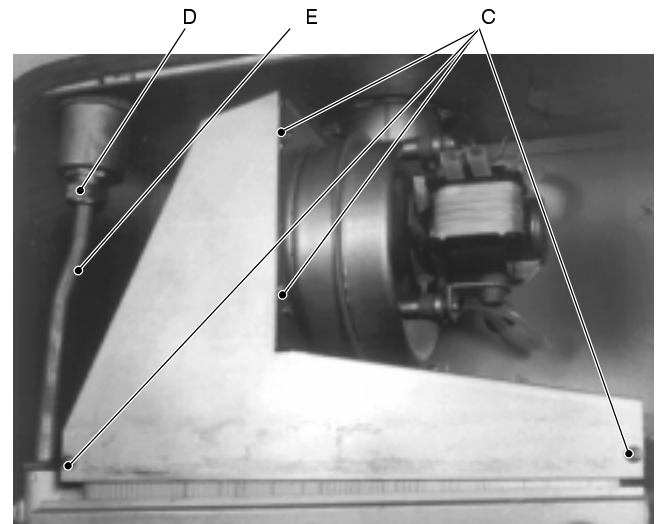

fig. 14b

- 6 Unscrew the automatic air valve connection nut D and remove the valve (fig. 14a);
- 7 Separate the heat exchanger from the hydraulic circuit, loosening the inlet and outlet pipe fittings;

For models 424 S, 424 RS...

- 8a move the right pipe and free the right connection; lower the right side of the exchanger and extract it from the front;

For model 428 S...

- 8b Extract the heat exchanger, from the front;
- 9 Unscrew the pipe E (fig. 14b) from the heat exchanger;
- 10 Assemble the heat exchanger carrying out the removal operations in reverse sequence.

5.3 Cleaning

If there are deposits of soot or dirt between the blades of the heat exchanger, clean with a brush or non-metallic bristle brush.

In any case, avoid any actions that can damage the protective varnish with which the exchanger has been covered.

6 D.h.w. heat exchanger

6.1 Function

The d.h.w. heat exchanger (A in fig. 15) allows the instantaneous transferral of heat from the primary hydraulic circuit to the water destined for d.h.w. use.

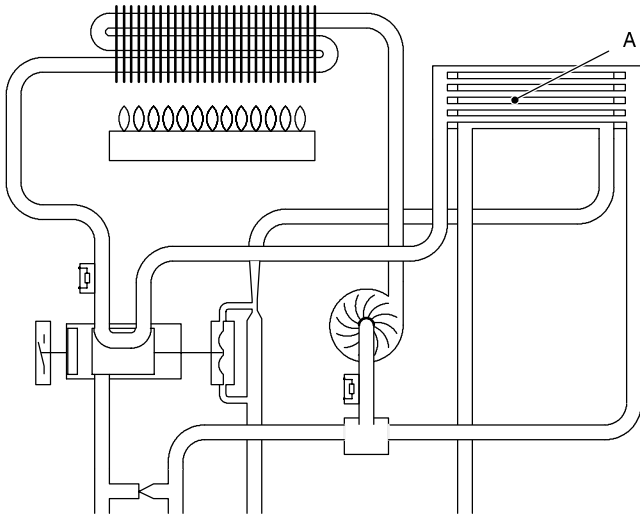

fig. 15

The schematic structure is shown in fig. 16.

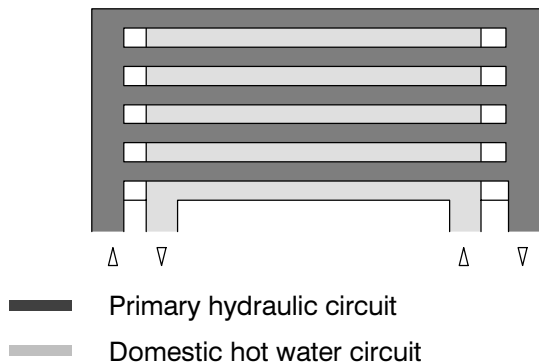

fig. 16

6.2 Removal

Warning: isolate the boiler from the mains electricity supply before removing any covering or component.

- 1 Empty the primary circuit and the d.h.w. circuit of the boiler

- 2 Remove the front panel of the case and lower the instrument panel
- 3 Completely unscrew the two Allen key screws B (in fig. 17 the right one is shown) which hold the exchanger to the brass deviator groups;

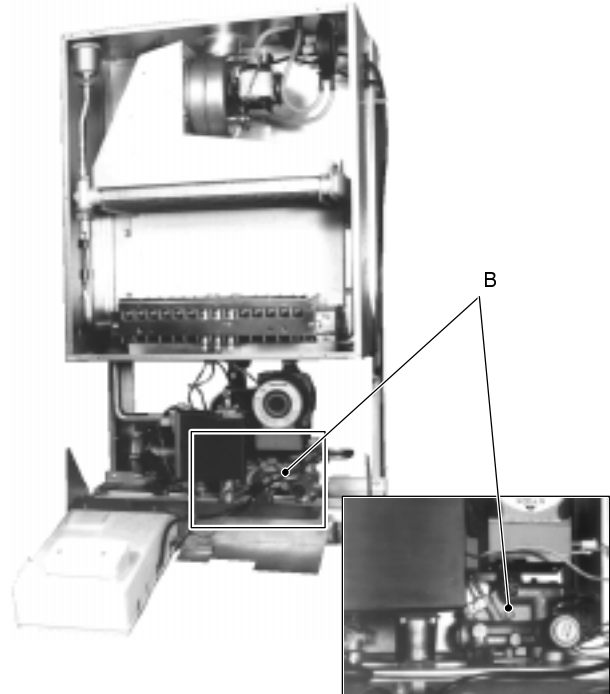

fig. 17

- 4 Move the exchanger towards the rear side of the boiler and extract it.

Reassemble the d.h.w. heat exchanger carrying out the removal operations in the reverse order.

Attention. Reassembling the exchanger be sure to put the off center location/securing pin indicated in fig. 18 towards the left side of the boiler.

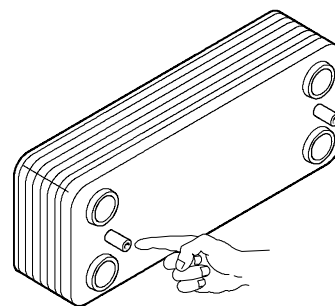

fig. 18

7 Pump

7.1 Function

The pump (A in fig. 19) has the function of making the water in the main circuit circulate through the main heat exchanger and therefore through the c/h system (during the c/h function) or through the secondary heat exchanger (during the d.h.w. function).

Note: the pump can be stopped by the intervention of the low limit water pressure switch.

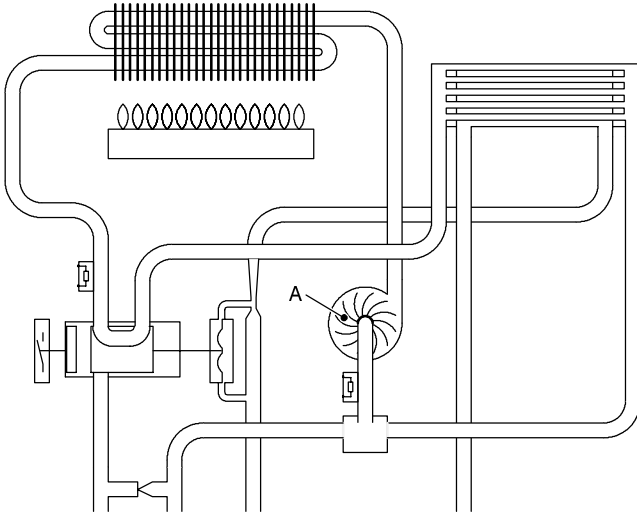

fig. 19

7.2 Checks

Warning: isolate the boiler from the mains electricity supply before removing any covering or component.

Check that the pump is not seized and that the movement of the rotor is not subject to mechanical impediments.

With the boiler off, remove the front panel and lower the instrument panel. Remove the air release plug of the pump and turn the rotor with a screwdriver.

Check the electrical completeness.

Remove the service panel, disconnect the connector to the electronic control circuit (see electrical diagram) and measure the electrical resistance between the pump supply conductors. (fig. 20).

Electrical resistance of the windings (at ambient temperature) on switch position 3 must be about:

- 210 Ω – Myson CP53
- 180 Ω – Myson CP63 (high head alternative)
- 220 Ω – Salmson MYE30
- 120 Ω – Salmson MYL50 (high head alternative)

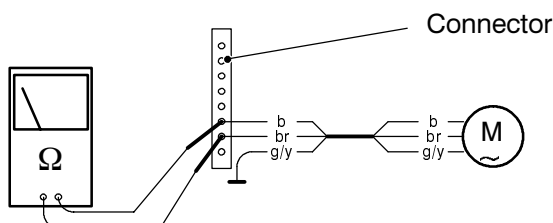

fig. 20

Check the absence of starting defects.

With the boiler off remove the front panel and lower the control panel;

for Myson pump: unscrew the plug of the pump by hand (the plug cannot be removed). Pull it and turn the rotor. Start the boiler and verify if the motor runs.

for Salmson pump (high head alternative): remove the air release screw of the pump. Start the boiler and with a screwdriver, have the rotor turn in the direction of the arrow. If there is a defect in starting, the rotor will begin to turn normally only starting it manually.

Check that the impeller is integral with the rotor.

Remove the pump head losing the screws which hold it to the pump body and check that the impeller is firmly jointed with the rotor.

7.3 Removal

Warning: isolate the boiler from the mains electricity supply before removing any covering or component.

If the clearance to the right side of the boiler is restricted, the removal of the pump can be easily achieved by first removing the head by unscrewing the four Allen keys screws (B in fig. 21, the two on the upper side indicated).

- 1 Empty the main circuit of the boiler.
- 2 Remove the front panel of the case, the right side panel and lower the control panel.
- 3 Disconnect the connector C (fig. 21).
- 4 Completely unscrew the connection nuts D and remove the pump.
- 5 Before the reassembling, carefully clean the support seat of the gasket.
- 6 Reassemble the pump carrying out the removal operations in the reverse order.

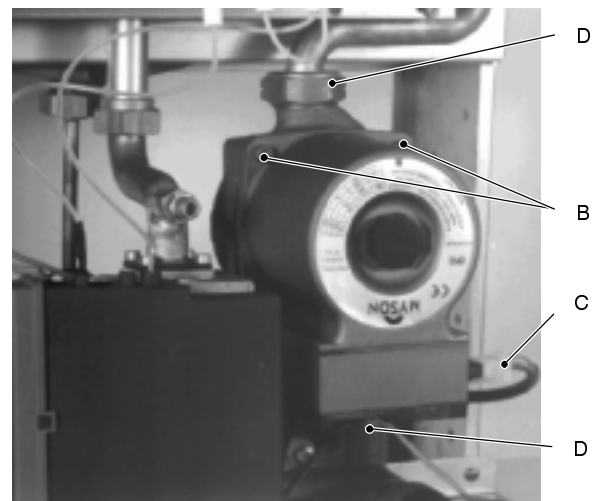

fig. 21

8 Diverter valve and d.h.w. pressure switch

8.1 Function

The diverter valve (A in fig. 22) has the function of modifying the hydraulic circuit of the boiler by means of an hydraulic command given by the opening of a d.h.w. tap in order to send the water that exits the main heat exchanger towards the c/h system or towards the d.h.w. heat exchanger.

Moreover it operates the d.h.w. pressure switch which acts on the electronic control circuit.

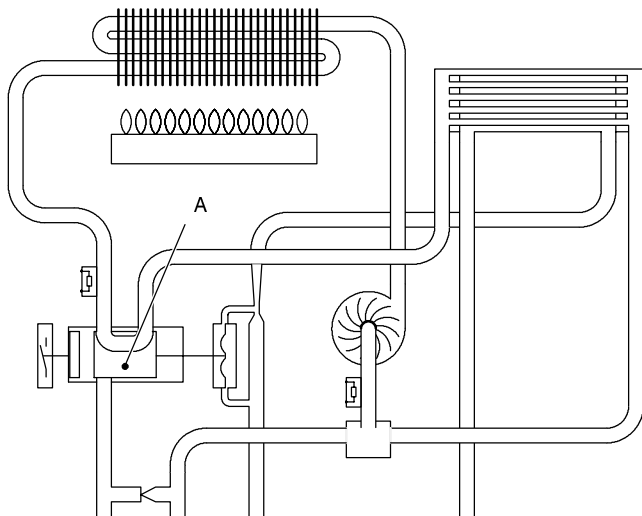



fig. 22

8.2 Checks

General check

It is possible to verify the general operation of the valve by measuring the voltage between the leads of the d.h.w. pressure switch during the operation on c/h and d.h.w.

Warning: isolate the boiler from the mains electricity supply before removing any covering or component.

- 1 Switch off the boiler and open the control panel.
- 2 Connect a meter, set for direct voltage measurement, to the points indicated in fig. 23.
- 3 Switch the boiler on  position and verify the voltages during c/h and d.h.w. by matching the readings with the values indicated in the section 3.3.

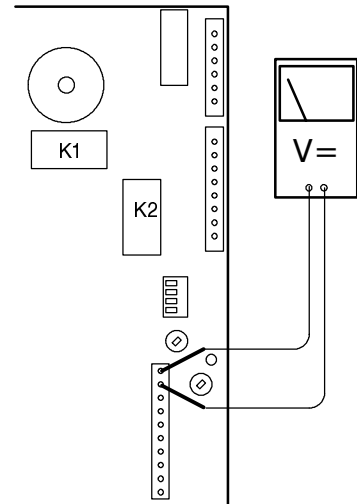

fig. 23

Check the mechanical function

- 1 Switch off the boiler; remove the front panel of the case, the lower protection plate and lower the control panel.
- 2 Remove the pressure switch as explained in the section 8.3 "Removal of the switch".
- 3 Open and close a d.h.w. tap and verify the position of the shaft B referring to fig. 24.

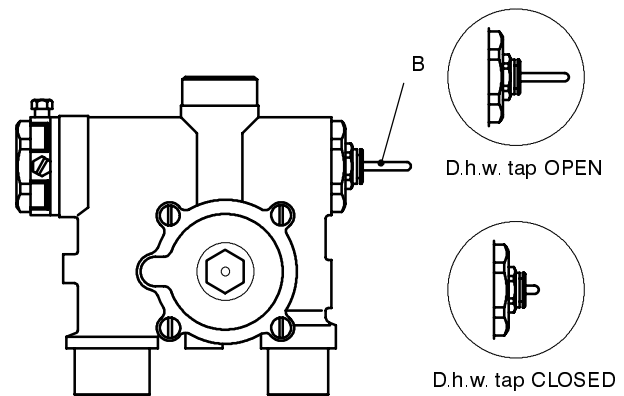

fig. 24

8.3 Removal

Warning: isolate the boiler from the mains electricity supply before removing any covering or component.

Removal of the membrane

- 1 Remove the front panel of the case, lower the control panel and empty the d.h.w. circuit.
- 2 Remove the forks C and move away the pipes D. (fig. 25 – rear view of the boiler).

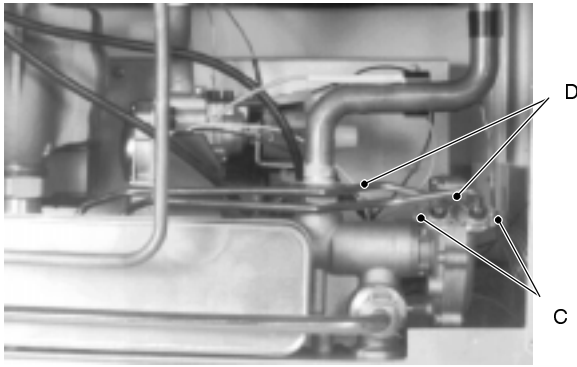

fig. 25

- 3 Loosen the screws *E* and remove the hydraulic actuator *F* (fig. 26).

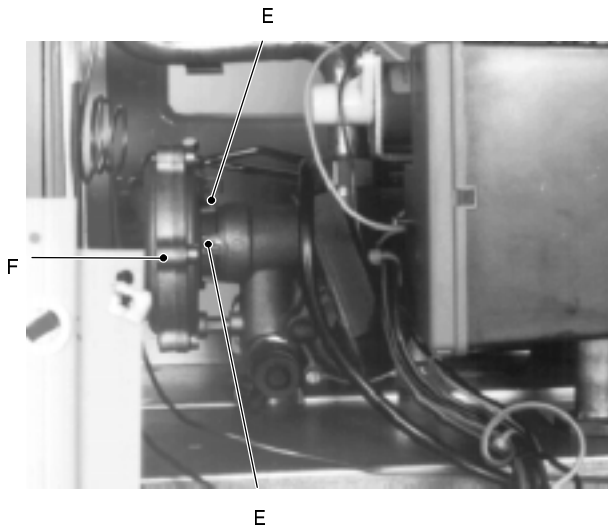

fig. 26

- 4 Unscrew the six screws *G*, open the hydraulic actuator and remove the membrane *H*. (fig. 27).

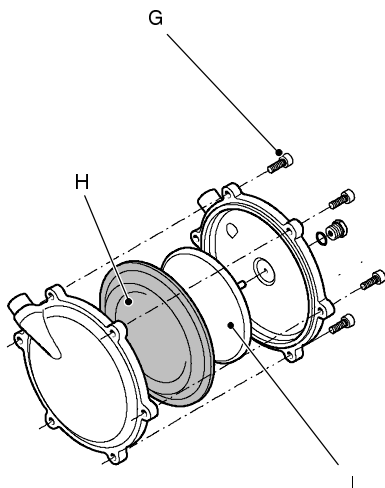

fig. 27

- 5 Assemble the part proceeding in reverse order.

Assembling the part, ensure to place the concave side of the membrane towards the actuator plate *I* (fig. 27).

When fixing the actuator to the valve, fit the reference shaft *J* in the seat of the valve (fig. 28).

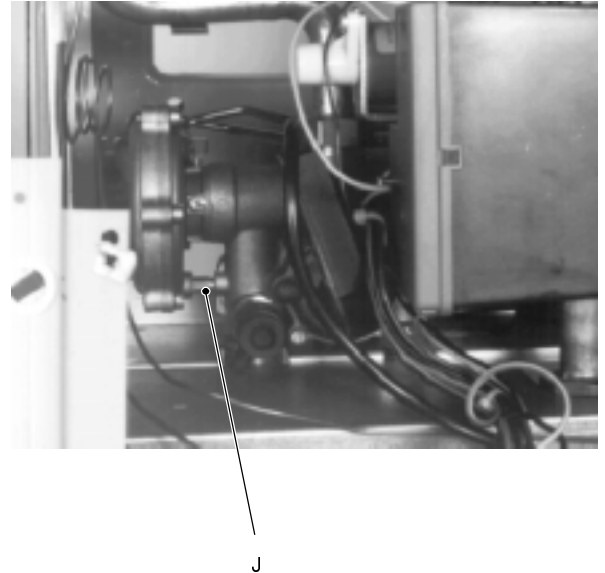

fig. 28

✓ Removal of the switch

- 1 Switch off the boiler; remove the front panel of the case, the lower protection plate and lower the control panel.
- 2 Remove the fork *K* that holds the d.h.w. pressure switch *L* placed on the right side of the valve and remove the switch (fig. 29).
- 3 Open the box and disconnect the switch.
- 4 Reassemble the switch proceeding in the reverse order.

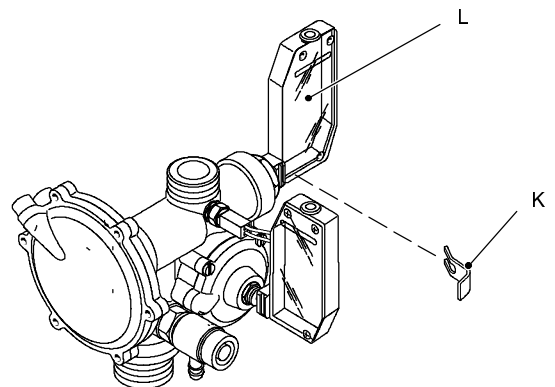

fig. 29

✓ Removal of the valve and the diverter mechanism

- 1 Switch off the boiler; remove the front panel of the case, the lower protection plate and lower the control panel.
- 2 Drain the d.h.w. and the c/h circuits.
- 3 Completely loosen the connections to the hydraulic circuits indicated in fig. 30.

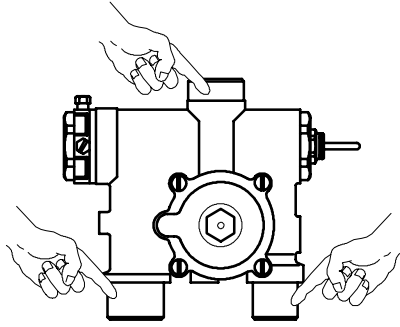

fig. 30

- 4 Remove the forks *M* and move away the pipes *N* (fig. 31).

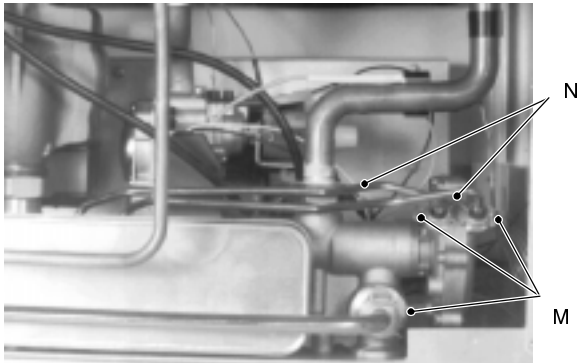

fig. 31

- 5 Remove the forks that hold the d.h.w. pressure switch *O* and the main circuit flow switch *P* and separate the switches from the valve (fig. 32).
- 6 Disconnect the temperature probe *Q*.

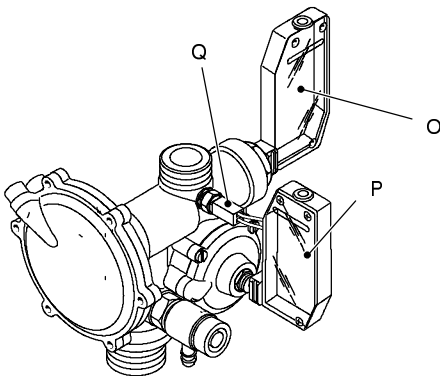

fig. 32

- 7 Unscrew the screw *R* that holds the d.h.w. heat exchanger, the bolt *S* that holds the valve to the frame (fig. 33) and remove the valve.

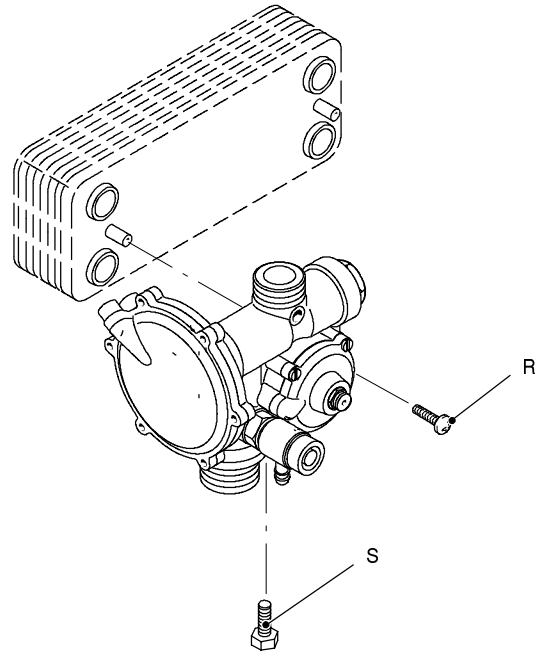

fig. 33

The diverter mechanism is composed by two parts. To reach them remove the hydraulic actuator as explained at the step 3 of the part *Removal of the membrane* of this chapter.

With a suitable spanner unscrew both plugs indicated in fig. 34 and remove the parts of the diverter mechanism.

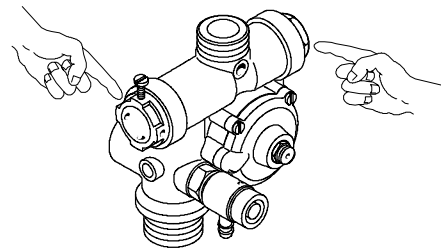

fig. 34

Reassemble the valve proceeding in the reverse order.

9 Electronic control circuit

9.1 Function

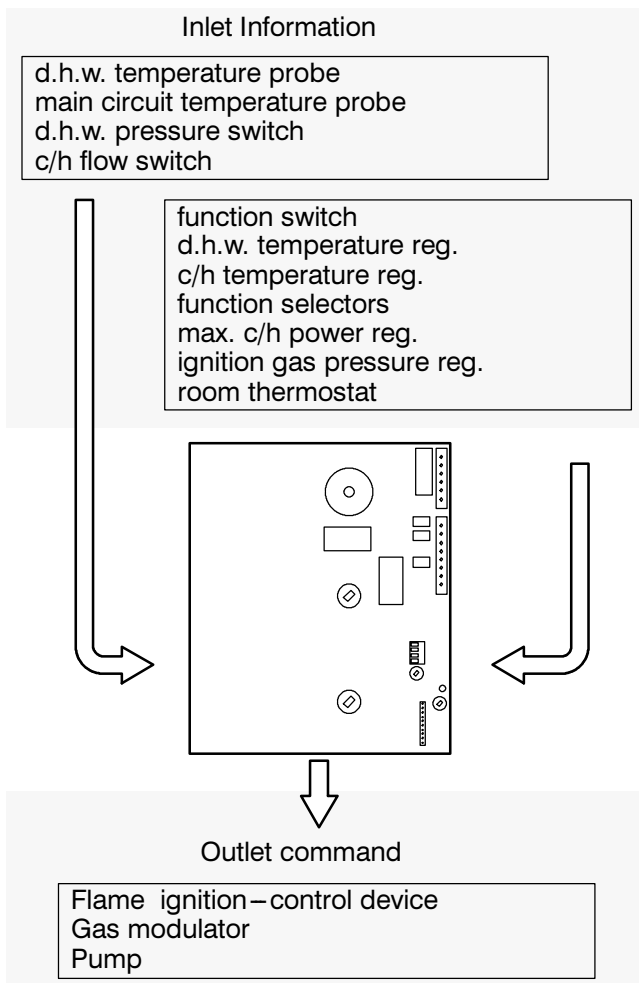

fig. 35

The fundamental function of the control circuit is that of controlling the boiler in relation to the external needs (heating the room, heating the water for d.h.w. use) operating in order to keep the temperature of the hydraulic circuits constant.

This is obviously possible within the useful power and maximum working temperature limits foreseen.

Generally, the control circuit receives inlet information coming from the boiler (the sensors) or from the outside (knobs, room thermostat, etc.), processes them and consequently acts with outlet commands on other components of the boiler (fig. 35).

9.2 Selection and adjustment devices

On the control circuit several selection, adjustment and protection devices are located. (fig. 36).

Several of these devices are directly accessible by the user (function switch, temperature adjustment potentiometers etc.) others are accessible by removing the cover.

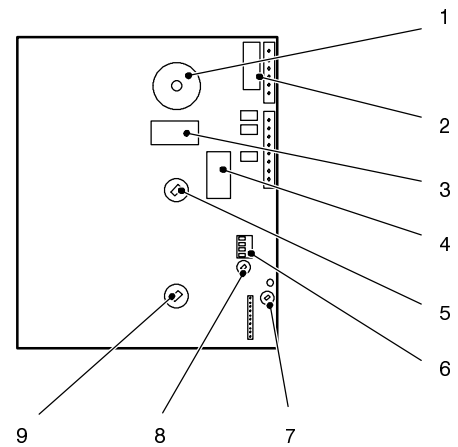

fig. 36

- 1 function switch
- 2 fuse F2 (1,6 A)
- 3 K1 relay
- 4 K2 relay (ignition device control)
- 5 d.h.w. temperature reg. potentiometer
- 6 function selectors
- 7 c/h maximum power adjustment (RISC.)
- 8 ignition gas pressure adjustment (ACC.)
- 9 c/h temperature reg. potentiometer

9.3 Checking the temperature

The control circuit makes it possible to separately adjust the c/h water flow and d.h.w. outlet temperature.

The temperature of the water is converted into an electric signal by means of temperature probes.

The user, setting the desired temperature with the knobs of the instrument panel operates the variable elements (5 and 9 in fig. 36) of the control circuit.

If the power requested is lower by about 40% of the maximum useful output, the control is done by igniting at the minimum power and turning off the burner (on-off function). If the power is higher the boiler will modulate down to 40% of its maximum power output.

When the boiler functions in c/h (fig. 37), the signal coming from the primary temperature probe is compared to the signal given by the instrument panel through the adjustment made by the user (knob 9). The result of such a comparison operates the modulation of the gas valve, consequently changing the instantaneous useful output of the boiler.

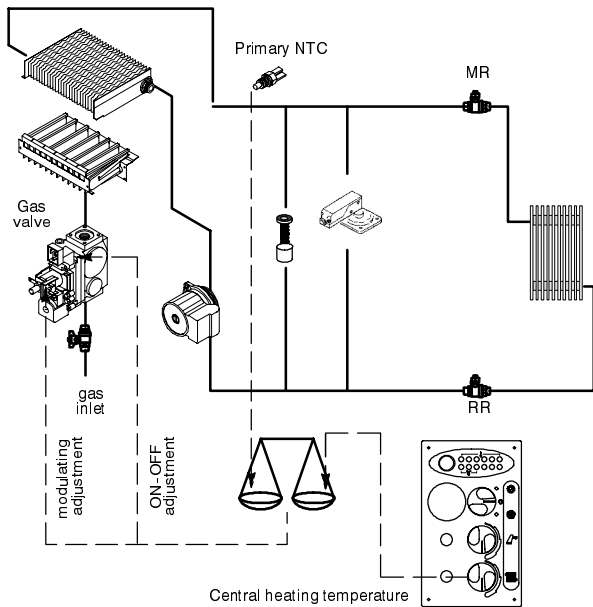

fig. 37

When the boiler functions in d.h.w. (fig. 38), the signal coming from the d.h.w. temperature probe is compared with the signal given by the instrument panel through the adjustment made by the user (knob \curvearrowright).

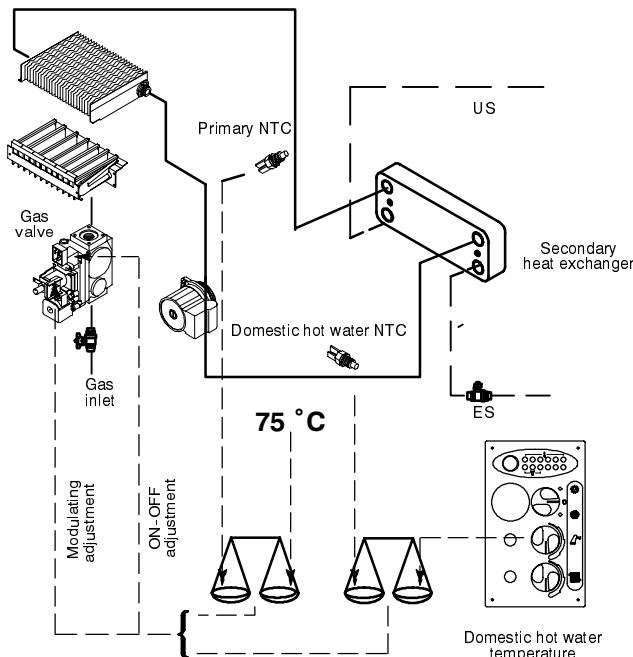

fig. 38

Normally, the result of the comparison between these two signals directly operates the adjustment elements of the gas valve, adjusting the useful output generated in order to stabilize the temperature of the exiting water.

If during the functioning in d.h.w. mode, the temperature of the primary circuit goes over 75°C, the useful output is automatically reduced so that the primary circuit cannot reach excessive temperatures.

The control sequences in \odot function and in \ast function are illustrated in detail in sections 9.9 and 9.10.

9.4 Function selectors

The function selectors "6" (fig. 36 and fig. 39) are microswitches with which it is possible to select the various modes of functioning of the boiler.

In fig. 39 the selectors are illustrated in the configuration in which the p.c.b. is set in the factory (natural gas boiler).

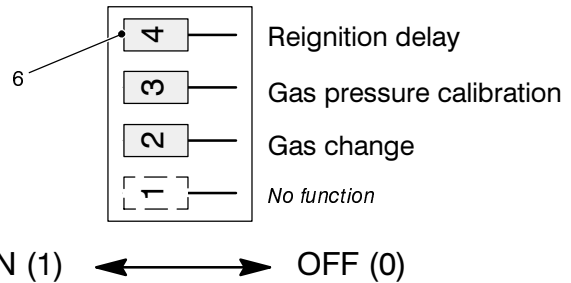

fig. 39

○ Selector 2

It selects the functioning of the boiler on the basis of the type of gas used.

It allows the selection of the maximum supply current given to the modulator device.

To set correctly the selector follow the table of fig. 40.

Gas supply	Position of selector	Approx. Max current through the modulator device
Natural gas	On	120 mA
L.P.G.	Off	165 mA

fig. 40

○ Selector 3

It forces the functioning of the boiler in order to permit the optimal gas pressure at the burner to be adjusted during the ignition phase.

The adjustment (see section 9.5) is done by means of the potentiometer "8" marked "ACC" (fig. 36).

After the adjustment operations bring the selector back to the normal position (ON).

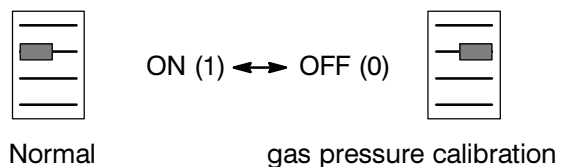

fig. 41

○ Selector 4

It makes it possible to select the minimum time that must pass between two ignitions of the burner in c/h function.

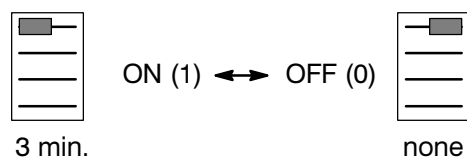

fig. 42

9.5 Ignition gas pressure regulator

By using the device "8" (fig. 36) marked "ACC." on the circuit board, it is possible to adjust the gas pressure at the injectors in the ignition phase.

This pressure is maintained at the injectors until ignition occurs (ionization signal).

To carry out the adjustment move the function selector n° 3 downwards (adjustment) and use the adjustment device "8" (ACC).

Bring the gas pressure at the injectors to the value indicated in the tables "data for gas adjustment" stated for each model in the second part of the manual (ignition pressure).

By rotating the device clockwise the pressure increases.

Check the regular ignition of the burner by turning the boiler on and off repeatedly.

After the adjustment operation move the selector upwards (normal).

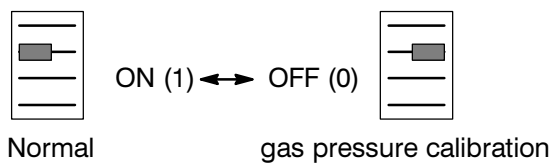

fig. 43

9.6 Max. c/h power regulator

By using device 7 (fig. 36) marked "RISC." on the circuit board, you can limit the maximum useful output delivered in the c/h function. This adjustment does not influence the maximum useful output delivered in d.h.w. function.

By rotating the device clockwise the pressure increases.

9.7 Checks

✓ Check that the fuse is complete

If the control circuit does not supply any device (pump, gas valve, etc.) check that the fuse F2 is complete (fig. 44).

The F2 fuse can be reached by removing the panel cover.

If the fuse is blown replace it with one that has the same characteristics after having identified the cause of the interruption.

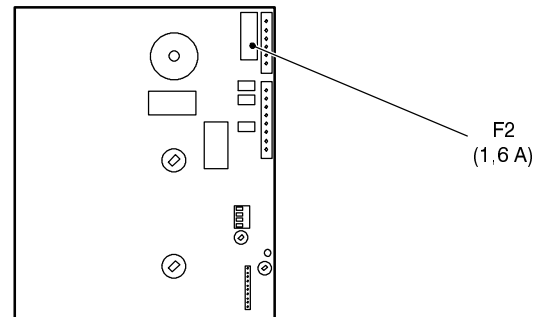

fig. 44

9.8 Removal of the control circuit

⚡ **Warning: isolate the boiler from the mains electricity supply before removing any covering or component.**

- 1 Remove the cover of the control panel as described in the section 2.3 of this manual;
- 2 Delicately flex the hooks indicated in fig. 45 and disconnect the four connectors A

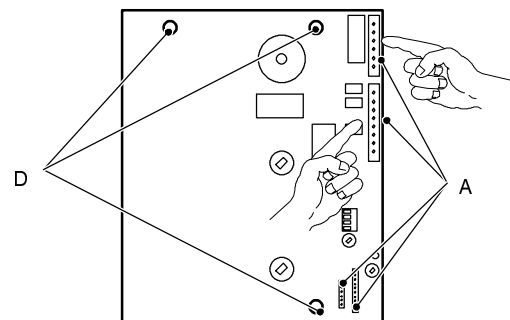

fig. 45

- 3 unscrew the three screws B and move away the bracket C (fig. 46);

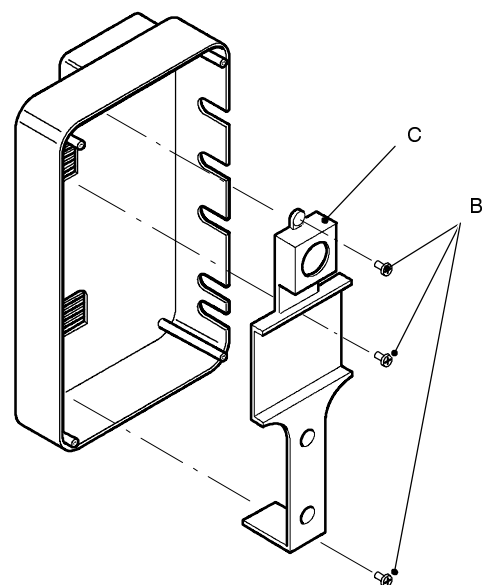

fig. 46

- 4 unscrew the three screws D and remove the circuit (fig. 45);

- 5 assemble the control circuit following the disassembly procedures in the reverse order.

Attention: in order to facilitate the mounting of the cover:

- 1 position the knobs of the panel as illustrate in fig. 47;

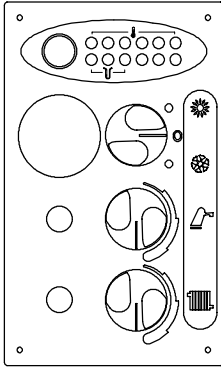

fig. 47

- 2 insert the spindles in the potentiometers *E* and *F* (fig. 48) and rotate them fully clockwise;
- 3 extract the spindles and insert them with the flat side pointing in the direction shown in fig. 48;

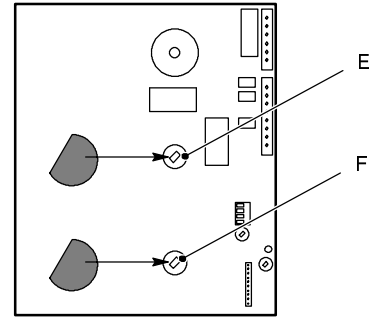



fig. 48

- 4 position the spindles as in fig. 49 and mount the panel cover.

After having installed the control panel make sure the central heating () and domestic hot water temperature () adjustment knobs can move freely (half a turn).

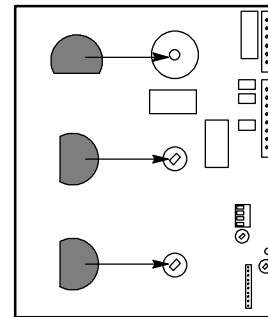

fig. 49

9.9 Thermal control in the "❄" mode

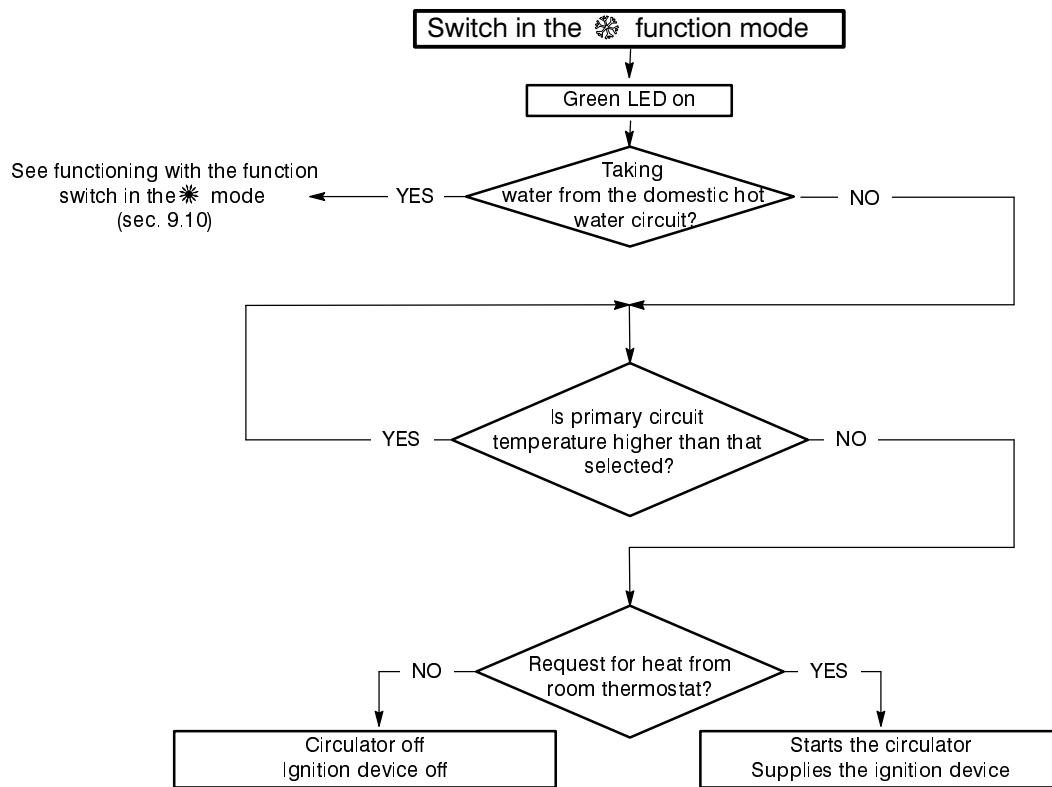

fig. 50

9.10 Thermal control in the "❄" mode

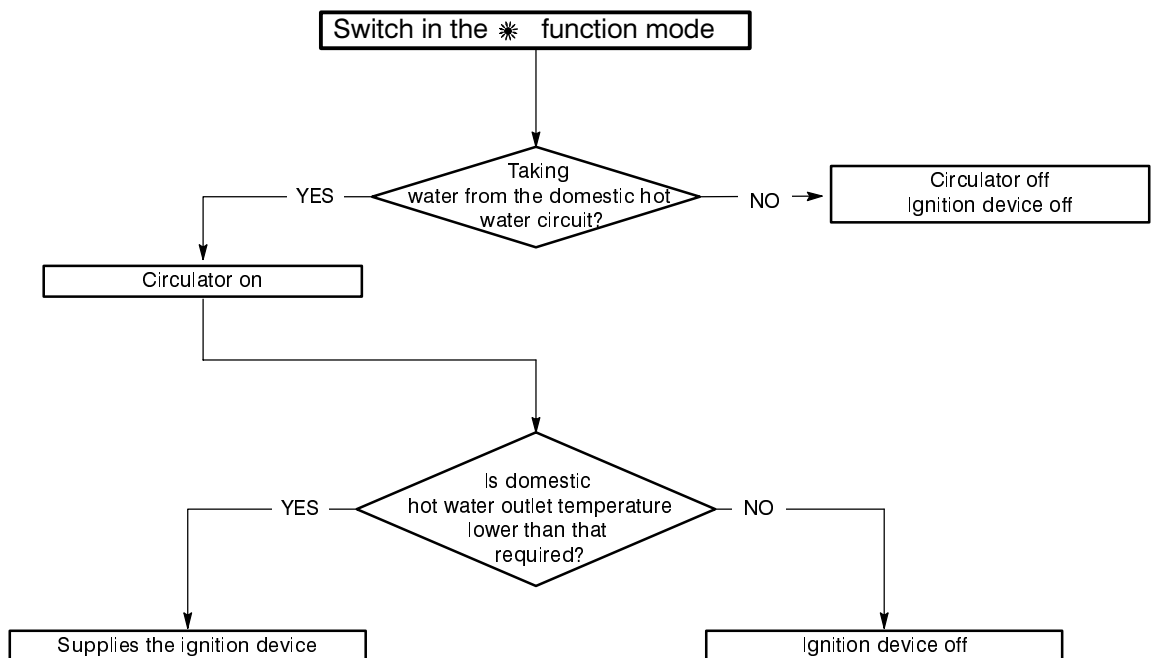

fig. 51

10 Display circuit

10.1 Function

The boiler is equipped with a pcb that displays some information about the operation of the appliance.

The electric signals that operate the display circuit are given directly by the electronic control circuit or by the water pressure switches.

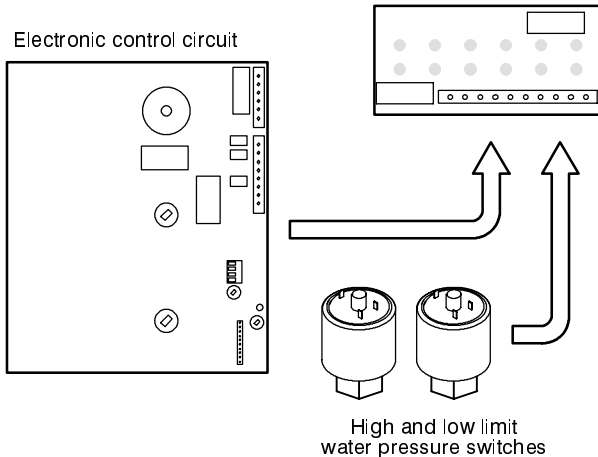

fig. 52

10.2 Display circuit operation

The following drawing (fig. 53) and list illustrate the position of each light and its function.

The colours are referred to the transparent windows of the control panel cover.

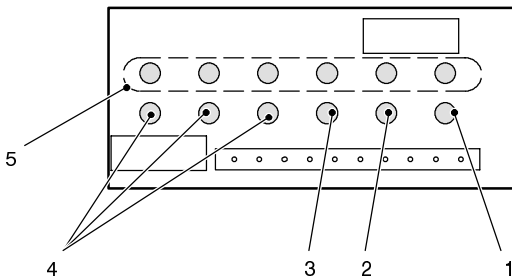

fig. 53

1 Boiler on – green

It indicates the operation of the boiler.

When the boiler is switched on, the indicator is continuously lit except after the extinction of the burner during the c.h. operation.

In this condition the light flashes for a period of 3 minutes indicating the reignition delay state of the boiler. This flashing indication is not affected by the position of the function selector on the control circuit (see sect. 9.4).

Switching the boiler on, the light could remain switched off for a period not longer than 20 seconds due to the reset time of the control system.

2 Heat request – green

This light indicates the heat request signal from the electronic control circuit and it comes on when the water temperature (d.h.w. or c.h. circuit) is lower than the requested on the control panel.

During d.h.w. operation it coincides with the ignition of the burner.

During c.h. operation the light could be on and the burner could remain off due to the room thermostat and/or time switch that don't call for heat.

3 D.h.w. request – green

This light comes on when the boiler operates on d.h.w.

4 Main circuit pressure – yellow / green / red

These lights indicate the pressure of the water in the main (c.h.) circuit.

If the left one (yellow) is on, this means that the pressure is too low (approx. below 1 bar). If the right one (red) comes on, the water pressure is too high (approx. over 2 bar).

The central light (green) indicates the right pressure and the correct filling of the circuit.

5 Main circuit temperature – green / yellow

These lights indicate the water temperature in the main (c.h.) circuit.

All the lights are green with the exception of the right one that is yellow and indicates the highest temperature.

Only one at a time of these light is turned on.

The lights are turned on referring to the signal that comes from the central heating temperature probe. Consequently, the reading of the temperature can be altered by a faulty temperature probe.

10.3 Removal

Warning: isolate the boiler from the mains electricity supply before removing any covering or component.

- 1 Remove the cover of the control panel as described in the section 2.3 of this manual;
- 2 disconnect the connector A, remove the two screws B (fig. 54) and remove the circuit board;

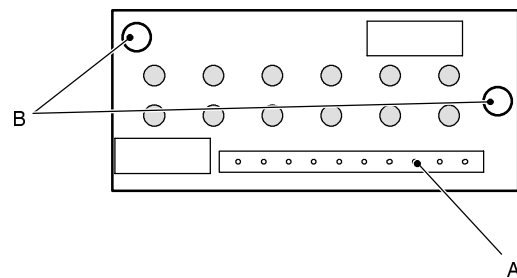

fig. 54

- 3 assemble the circuit following the disassembly procedures in the reverse order.

11 Full sequence ignition device

11.1 Function

The ignition and flame control device, type S4565DD, used on electronic ignition boilers with forced flue gas expulsion carries out the following fundamental functions:

- does a sequence of operations (ignition cycle) which lead to the ignition of the gas at the burner
- checks the presence of the flame during the entire period in which it is activated
- supplies the fan and checks its functioning by means of the signal coming from the flue gas pressure switch.

The ignition device is supplied by the electronic control circuit when the ignition of the burner is requested.

The ignition device has a **safety function** and any incorrect interventions or tampering can result in conditions of dangerous functioning of the boiler.

The ignition device can lock the functioning of the boiler (lock state) and stop its functioning up to the resetting intervention. The lock is signalled by the ignition of the lock lamp and the device can be reset only by using the reset push-button placed on the instrument panel.

Some components which are connected to the device that, can activate the lock state. The causes of a lock state could be:

- the intervention of the safety thermostat (primary hydraulic circuit)
- a fault on gas feeding
- faulty ignition (ignition electrode, its wiring and connection)
- faulty flame detection (detection electrode, its wiring and connection)
- gas injectors plugged
- faulty gas valve (on-off operators) or not electrically supplied
- faulty ignition device

other components like the flue gas pressure switch can temporarily stop the ignition of the burner but allow its ignition when the cause of the intervention has stopped.

fig. 57 shows the sequence of the operations that are carried out at the starting of every ignition cycle and during normal functioning.

11.2 Checks

✓ Shutdown sequence

Start the boiler until the burner is ignited.

While the burner is on, turn the gas supply off. The device should carry out a complete ignition cycle and then shutdown.

When turning the boiler on and off with the function switch, the device should not reset itself and the burner should not turn on.

11.3 Removal

⚡ **Warning: isolate the boiler from the mains electricity supply before removing any covering or component.**

- 1 Remove the front panel of the case and lower the control panel (see sect. 2.2);
- 2 unscrew the screw *A* and remove the protection cover *B*; disconnect the flame detection cable *C* and the ignition cable *D* (fig. 55);

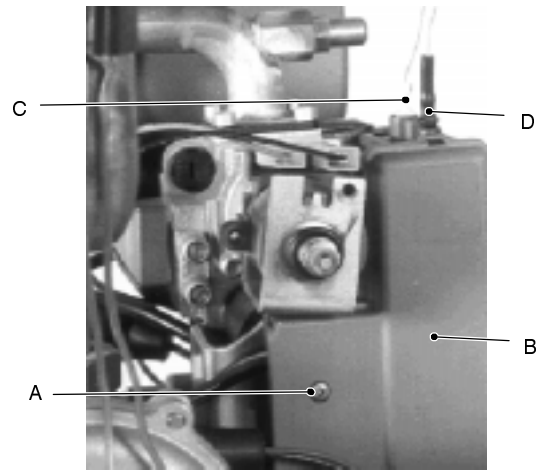

fig. 55 (view from the left side of the boiler)

- 3 remove the cable clamp and disconnect the two wires;
- 4 remove the ignition device by moving it from towards left (fig. 56);

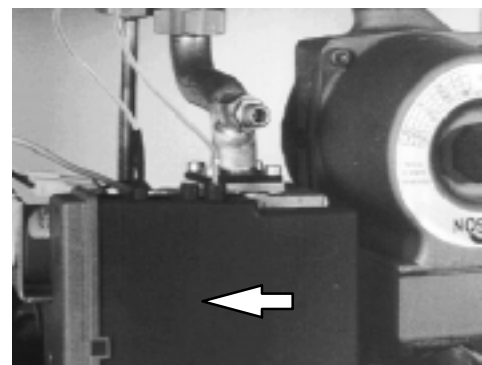

fig. 56

11.4 Ignition sequence

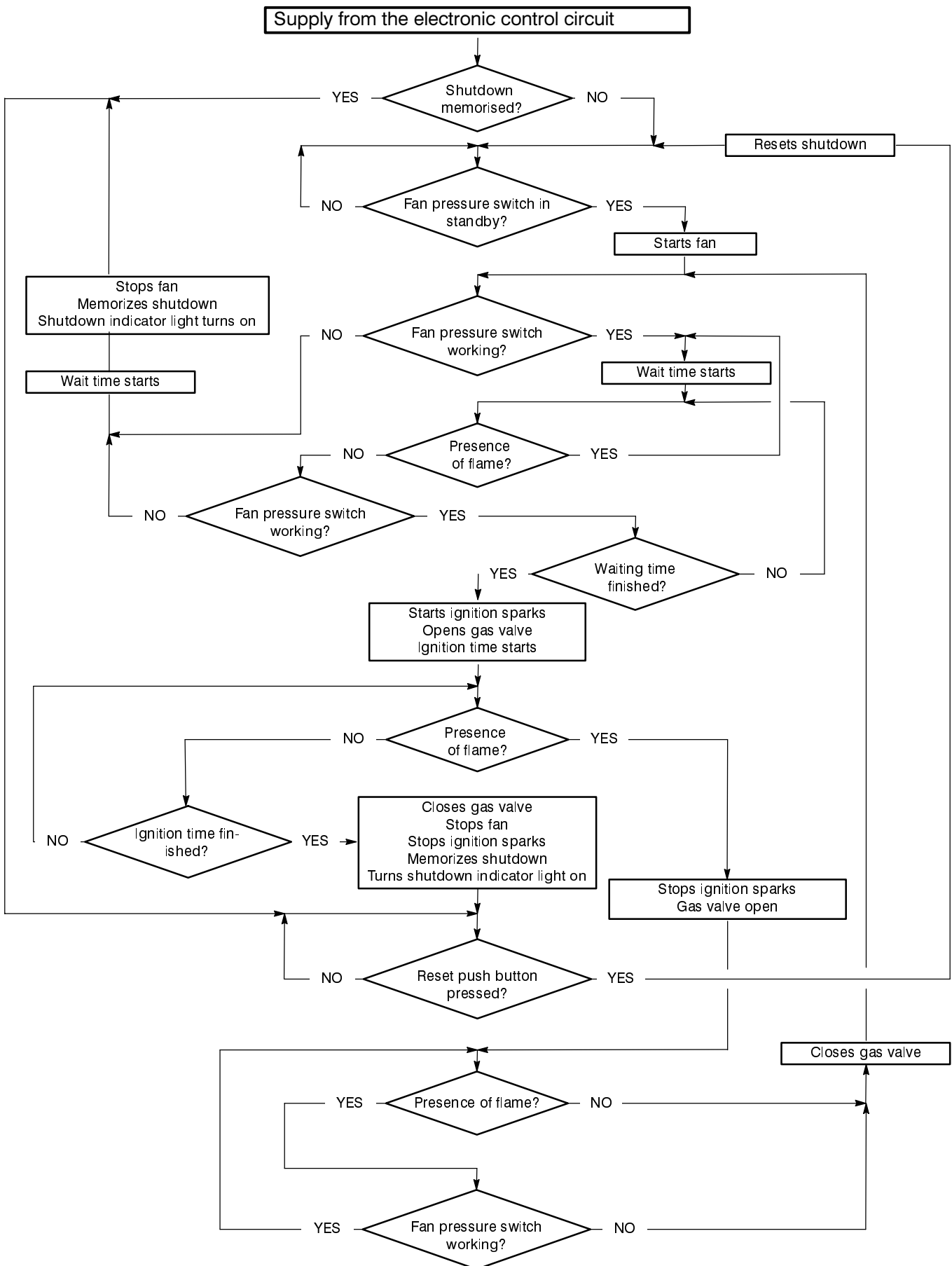

fig. 57

12 Gas valve

12.1 Function

The gas valve controls the gas inflow to the boiler burner.

By means of an electric command given to the on–off operators the passage of the gas through the valve can be opened or closed.

By means of an electric command given to the modulating operator the pressure can be varied and therefore the gas flow rate to the burner (modulation). The modulator device has mechanical organs which permit the adjustment of the minimum and maximum pressure exiting the valve.

12.2 Nomenclature of the parts

- 1 On–off operators
- 2 Modulating operator
- 3 Modulating operator's electric connectors
- 4 Valve inlet gas pressure test point
- 5 Valve outlet gas pressure test point
- 6 Gas pressure maximum adjuster
- 7 Gas pressure minimum adjuster

12.3 Adjustment

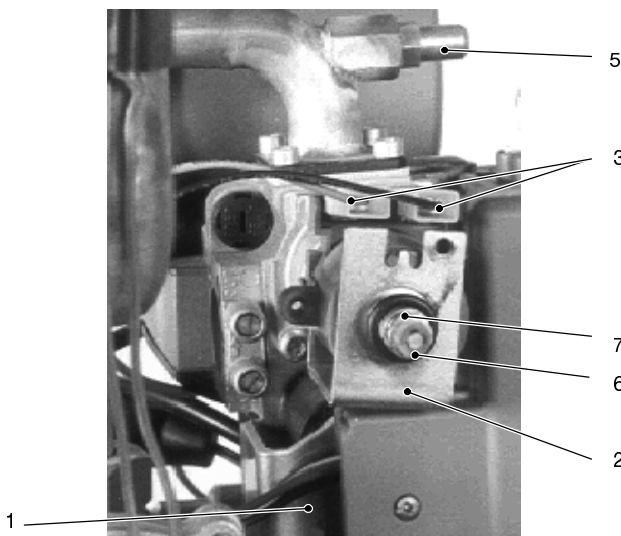

fig. 58 (view from the left side of the boiler)

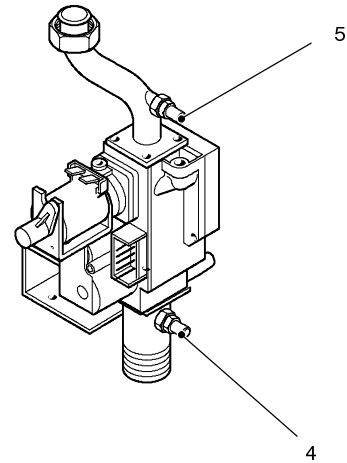

fig. 59

Warning: isolate the boiler from the mains electricity supply before removing any covering or component.

- 1 Remove the front panel of the case and lower the control panel as described in the section 2.2;
- 2 open the gas pressure tap "4" at the valve input, connect a gauge and check the gas pressure of the supply network;
- 3 close the gas pressure tap "4";
- 4 open the gas pressure tap "5" at the valve output and connect a pressure gauge;
- 5 remove the protection cap from the mechanical pressure adjustment elements;
- 6 disconnect one of the two connectors "3" of the modulating operator;
- 7 start the boiler;
- 8 rotate the minimum pressure adjuster "7" until you obtain the expected pressure (by rotating clockwise the pressure increases);
- 9 turn the boiler off and connect the wire to the modulating operator;
- 10 start the boiler;
- 11 rotate the maximum pressure adjuster "6" until you obtain the expected pressure (by rotating clockwise the pressure increases);
- 12 turn the boiler off and disconnect the gauge;

At the end of the adjustment ensure to seal the gas test point.

12.4 Checks

Warning: isolate the boiler from the mains electricity supply before removing any covering or component.

- Check the modulating operator coil
- 1 Remove the front panel of the case and lower the control panel.
- 2 Disconnect one of the two connectors "3" (fig. 58) of the modulating operator and measure the elec-

trical resistance of the coil.
Its electrical resistance value must be approx. 125 Ω .

- ✓ Check the modulating operator coil
- 1 Remove the front panel of the case and lower the control panel.
- 2 Remove the full sequence ignition device (see the section 11.3 of this manual).
- 3 Measure the electrical resistance between the leads of the on-off operators as illustrated in fig. 60.

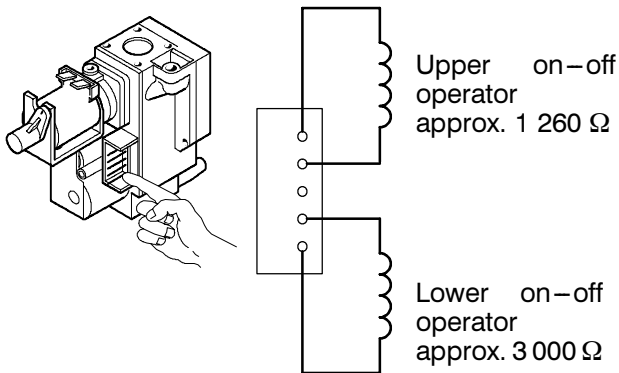

fig. 60

12.5 Removal

- ⚡ **Warning:** isolate the boiler from the mains electricity supply before removing any covering or component.

- 1 Remove the front panel of the case and lower the control panel.
- 2 Remove the full sequence ignition device (see the section 11.3 of this manual).
- 3 Disconnect the modulating operator.
- 4 Unscrew the eight screws indicated in fig. 61 and remove the valve.
- 5 Reassemble the valve carrying out the removal operations in reverse order.

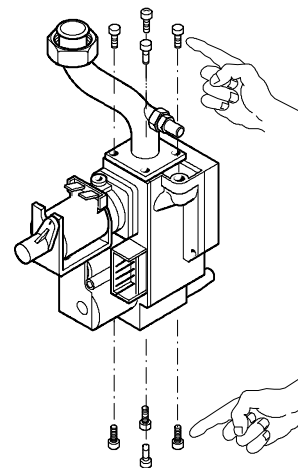

fig. 61

13 Main circuit flow switch

13.1 Function

The main circuit flow switch (A in fig. 62) is a device that controls the speed of water that crosses the main heat exchanger.

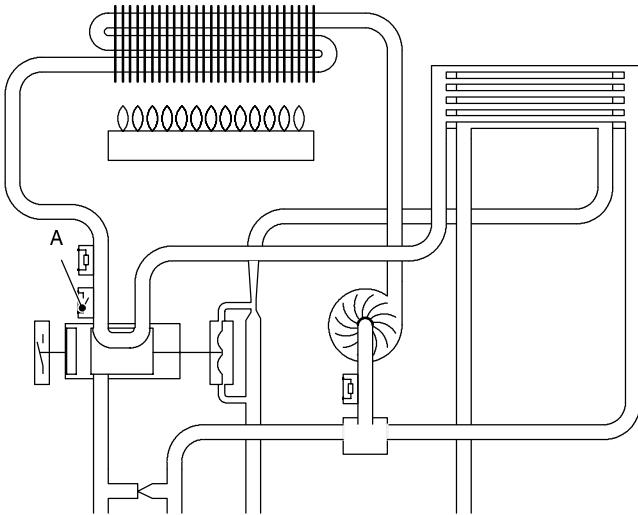

fig. 62

This device controls the regular functioning of the pump, the presence of water in the primary circuit of the boiler and the absence of obstructions of the main heat exchanger during the c/h function as well as during the d.h.w. function.

As a consequence of any one of these causes the main circuit flow switch cuts – off an electric circuit by means of a microswitch (B in fig. 64) installed on it.

The main circuit flow switch is connected to the electronic control circuit and its intervention prevents or stops the burner ignition cycle but does not send the boiler in the lock state.

13.2 Checks

⚡ **Warning: isolate the boiler from the mains electricity supply before removing any covering or component.**

✓ General check

It is possible to verify the general operation of the switch by measuring the voltage between its leads during the operation on c/h or d.h.w.

⚡ **Warning: isolate the boiler from the mains electricity supply before removing any covering or component.**

- 1 Switch off the boiler and open the control panel.
- 2 Connect a meter, set for alternating voltage (230V) measurement, to the points indicated in fig. 63.
- 3 Switch the boiler on ☼ position and verify the voltage by matching the readings with the values indicated in the section 3.3.

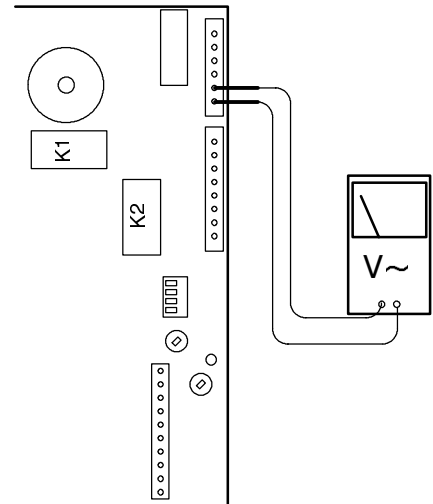

fig. 63

✓ Mechanical function

- 1 Remove the front panel of the case and lower the control panel as described in the section 2.2 of this manual.
- 2 Remove the fork C that holds the main circuit flow switch B (fig. 64).

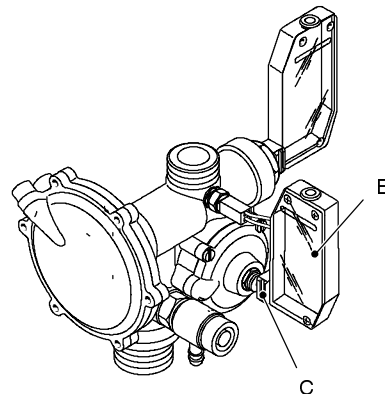

fig. 64

- 3 Start and stop the boiler in c/h operation (time switch and external controls must call for heat) and verify the position of the shaft D referring to fig. 65

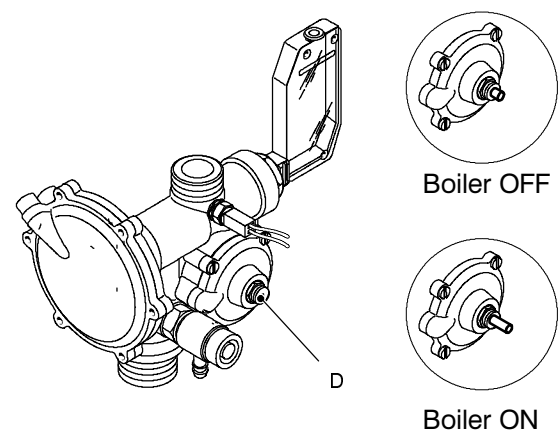

fig. 65

13.3 Removal

⚡ **Warning: isolate the boiler from the mains electricity supply before removing any covering or component.**

✓ Removal of the membrane

- 1 Remove the front panel of the case, lower the control panel and empty the main circuit.
- 2 Remove the fork *E* that holds the main circuit flow switch *B* (fig. 64).
- 3 Unscrew the four screws *F*, open the hydraulic operator and remove the membrane *G* (fig. 66).

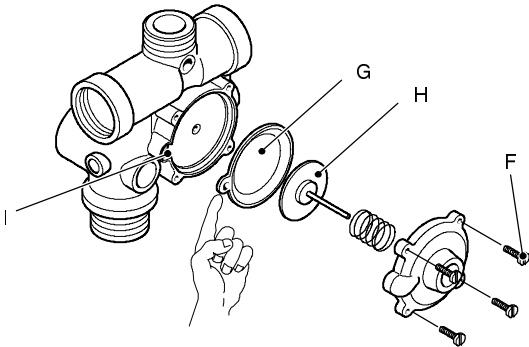

fig. 66

- 4 Assemble the part proceeding in reverse order.

Assembling the part, ensure to place the concave side of the membrane towards the actuator plate *H* and the reference hole indicated in the seat *I* (fig. 66).

✓ Removal of the switch

- 1 Switch off the boiler; remove the front panel of the case, lower the protection plate and lower the control panel.
- 2 Remove the fork *C* that holds the switch placed on the valve and remove the switch (fig. 64).
- 3 Open the box and disconnect the switch.
- 4 Reassemble the switch proceeding in the reverse order.

14 D.h.w. filter and flow limiter

14.1 General notes

The input port of the d.h.w. circuit is provided with a net filter and its function is to stop the passage of any impurities through the circuit.

The d.h.w. filter is located in the c.h. return group (indicated in fig. 67).

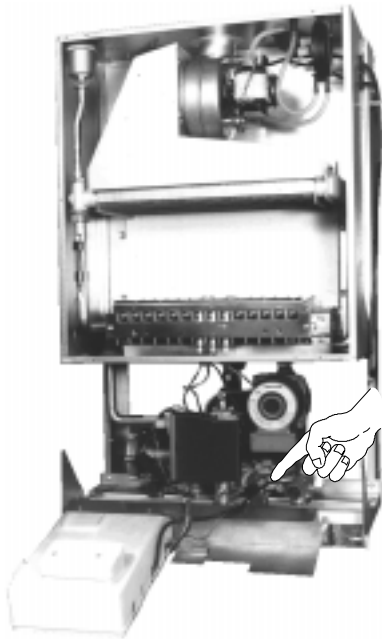

fig. 67

14.2 Removal of the filter

Warning: isolate the boiler from the mains electricity supply before removing any covering or component.

- 1 Remove the front panel of the case, the lower protection plate, lower the control panel and empty the d.h.w. circuit.
- 2 Unscrew the plug A (fig. 68) and extract the filter.

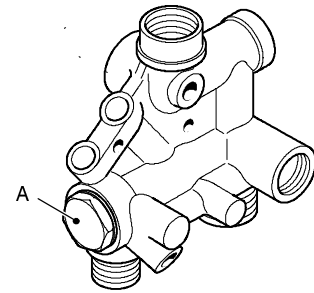

fig. 68

14.3 Flow limiter

424 S boilers are provided in the factory with a flow limiter rated at 10 litres/min.

If the flow rate of the d.h.w. circuit on the 428 S boiler is too high, it is also possible to limit it installing a flow limiter. The following sizes are available:

Nominal flow rate (litres/min)	Colour
10	Blue
12	Red

To install the flow limiter operate as in the following sequence:

- 1 Remove the d.h.w. filter as explained in the section 14.2.
- 2 Unscrew the part B (fig. 69) and remove it from the body of the filter.
- 3 Install the flow limiter C putting its smaller diameter side towards the part B.
- 4 Install the filter following the removing sequence in reverse order.

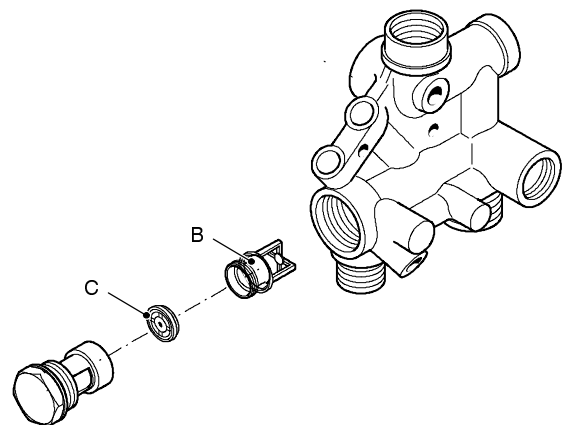

fig. 69

15 Temperature probes

15.1 Function

The temperature probe has the function of converting the temperature of the water of the hydraulic circuit where it is installed into an electric signal (resistance).

The relation between temperature and electrical resistance is stated in fig. 70.

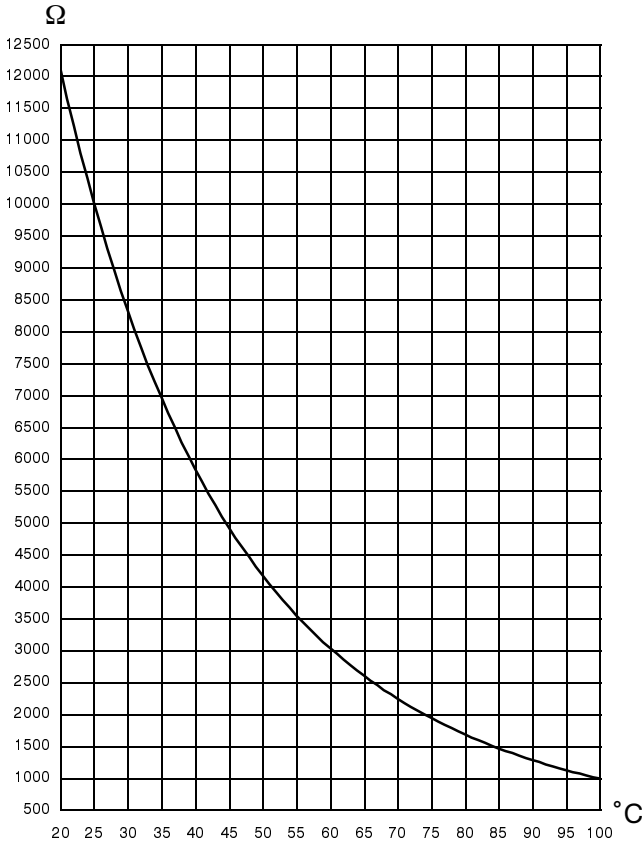

fig. 70

In the boilers with mixed function (c/h + d.h.w.) two temperature probes are assembled, one on the output of the main heat exchanger (main circuit temperature

probe) A, (fig. 71 and fig. 72) one on its input, before the pump (d.h.w. temperature probe) B (fig. 71 and fig. 73).

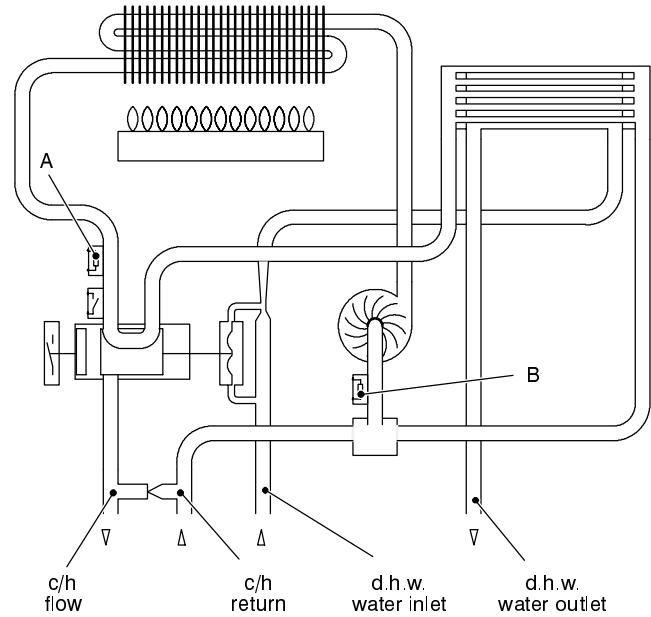

fig. 71

15.2 Checks

- ✓ Temperature-resistance relationship
- ⚡ **Warning: isolate the boiler from the mains electricity supply before removing any covering or component.**

Disconnect the cable from the temperature probe.

Measure the temperature of the pipe near the temperature probe and check the electrical resistance according to the graph in fig. 70.

Remember that a temperature probe failed in short circuit sends a signal to the control circuit at a temperature equivalent to 100°C. A disconnected or interrupted temperature probe sends a signal at a temperature equivalent 0°C thus the burner will always be on maximum power.

15.3 Removal

⚡ **Warning: isolate the boiler from the mains electricity supply before removing any covering or component.**

To remove the main circuit or the d.h.w. temperature probes follow the same sequence.

Refer to fig. 72 for the main circuit temperature probe, to fig. 73 for the d.h.w. temperature probe.

- 1 Remove the front panel of the case and lower the instrument panel;
- 2 empty the main circuit of the boiler;
- 3 remove the electric connector of the temperature probe and unscrew it;
- 4 assemble the temperature probe carrying out the removal operations in reverse order;

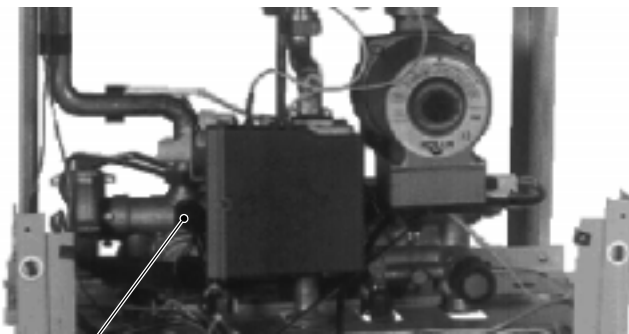

A
fig. 72

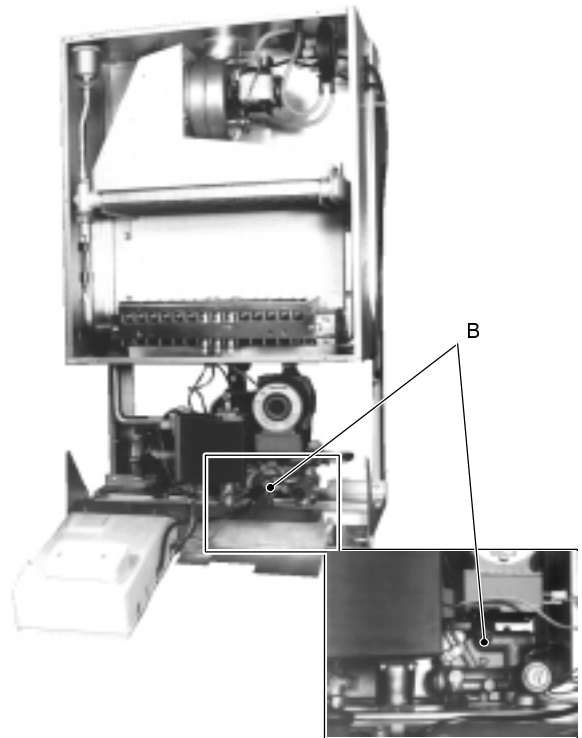

fig. 73

16 By-pass valve

16.1 Function

The by-pass valve is located between the c/h water flow and return (A in fig. 74) and its function is that of guaranteeing a minimum flow across the main heat exchanger also if the circulation across the c/h system is completely closed.

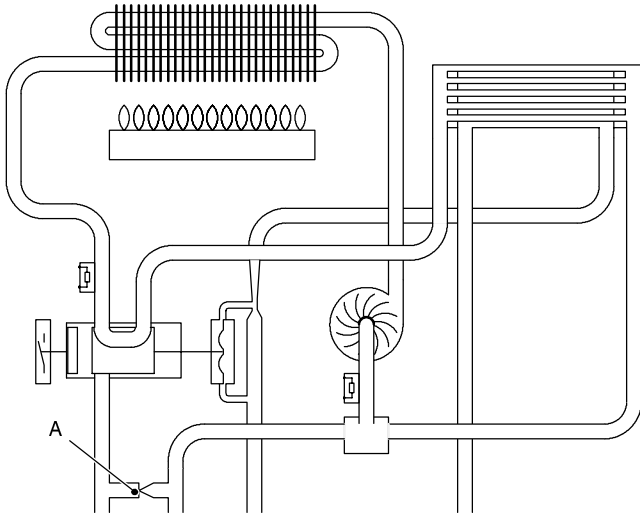

fig. 74

16.2 Removal

Warning: isolate the boiler from the mains electricity supply before removing any covering or component.

- 1 Remove the front panel of the case and lower the control panel;
- 2 empty the main circuit and the d.h.w. circuits of the boiler;

- 3 remove the hydraulic actuator B (fig. 75) as explained in the section *Diverter valve and d.h.w. pressure switch* of this manual;
- 4 remove the fork C and the pipe D.



fig. 75 (rear view of the boiler)

- 5 Unscrew the connector E and remove the by-pass valve F (fig. 76);

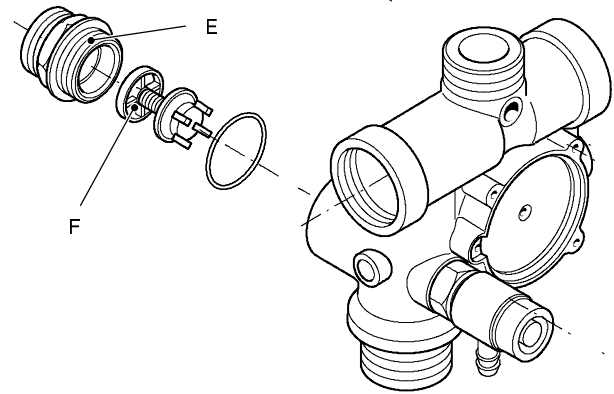

fig. 76

- 6 reassemble the by-pass valve as illustrated in fig. 76 and proceeding in reverse order.

17 Water pressure switch and pump relay

17.1 Function

The boiler is equipped with two water pressure switches which are connected to the main (c.h.) water circuit.

They have two different operating points and, by switching an electric circuit, they indicate the water pressure by means of the display circuit (fig. 77).

The lower limit pressure switch interrupts the power to the pump via the pump relay, in the event that the system pressure drops below 0.5 bar.

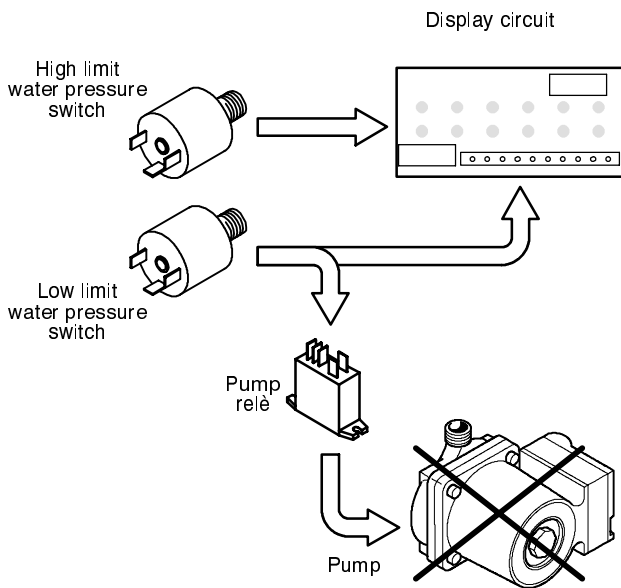

fig. 77

The high and low pressure switches can be identified by the color of the pastic plug situated on the end of each switch.

The table below gives further details.

Pressure switching point (bar)	Colour
0.5	Brown
2	Red

17.2 Checks

Warning: isolate the boiler from the mains electricity supply before removing any covering or component.

- 1 Switch off the boiler. Remove the front panel of the case, lower the control panel and empty the main circuit.

If you need to verify the operating point of the switches, connect a suitable water pressure gauge to a test point of the circuit near the boiler;

- 2 disconnect the connectors to the pressure switches and measure the electrical resistance between the connections (fig. 78).

When the circuit is empty, the contact between the connection COM and the connection NC must be closed; the contact between COM and NO must be open.

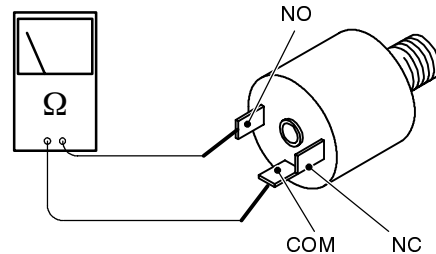

fig. 78

- 3 Gradually fill the circuit. The lower limit pressure switch (brown plug) must switch at a pressure of about 0.5 bar.

Verify that the contact between COM and NC is open and between COM and NO is closed.

- 4 To check the high limit pressure switch (red plug) further increase the pressure of the circuit. It must switch at a pressure of about 2 bar. Verify the contacts as explained above.

After this test, remember to decrease the water pressure to an adequate value.

17.3 Removal of the pressure switch

- 1 Empty the main circuit of the boiler;
- 2 remove the front panel of the body, the right side panel and lower the control panel;
- 3 disconnect the wirings from the pressure switch and unscrew it.
- 4 Reassemble the switch carrying out the removal operations in the reverse order.

Reassembling the pressure switch, refer to the diagram of the section 3.1 to connect correctly the wirings.

17.4 Removal of the pump relay

The pump relay is located under the display circuit. To remove it:

- 1 gain acces to the electric parts of the control panel (see sect.2.3):
- 2 remove the display circuit (see sect.10.3)
- 3 disconnect the wirings and remove the relay.

18 Flue fan, venturi, air pressure switch

18.1 Function

The boiler has a fan whose function is that of forcing the expulsion of the products of combustion.

The fan is supplied by the full sequence ignition device at the beginning of the ignition cycle.

Its correct functioning is controlled by means of a system of a built in venturi device and an air pressure switch.

18.2 Checks

✓ Check of the fan

⚡ **Warning: isolate the boiler from the mains electricity supply before removing any covering or component.**

Remove the front panel of the body and the lid of the sealed chamber.

Disconnect the connectors A (fig. 79) and measure the electrical resistance of the motor that has to be about 47 Ω.

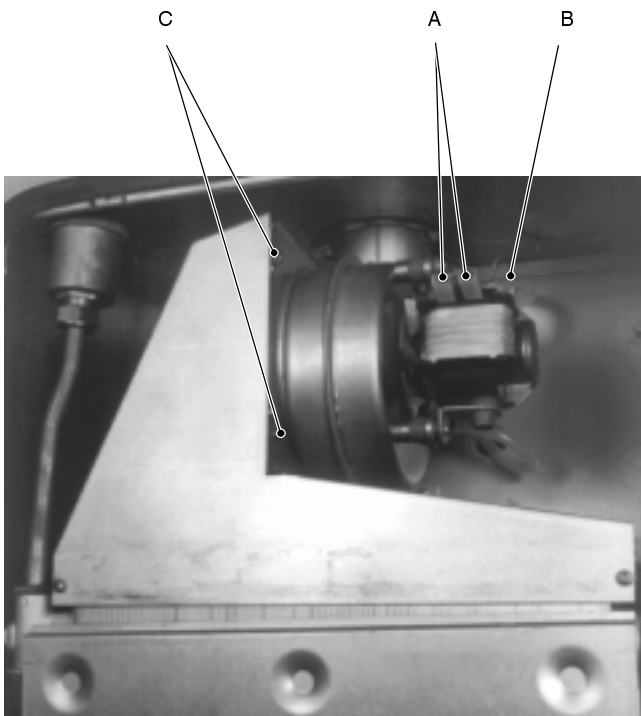

fig. 79

✓ Check of the air pressure switch operation

⚡ **Warning: isolate the boiler from the mains electricity supply before removing any covering or component.**

- 1 Remove the front panel of the body and the lid of the sealed chamber
- 2 Disconnect the wires and check the electrical resistance between its connections

Between COM and NO the contact must be open.

Between COM and NC the contact must be closed (electrical resistance zero).

Refer to the fig. 80a b or c in accordance with the type of air pressure switch used.

These switches are interchangeable.

- 3 Connect the black wire (COM) and the brown wire (NC).
 - 4 Run the boiler (the fan must run) and check the the electric resistance between COM and NO
- Between COM and NO the contact must be closed (electrical resistance zero)

Remember that in this condition the boiler runs only for the ignition safety time and than it goes on safety lock – out. The above described test has to be carried out during this period.

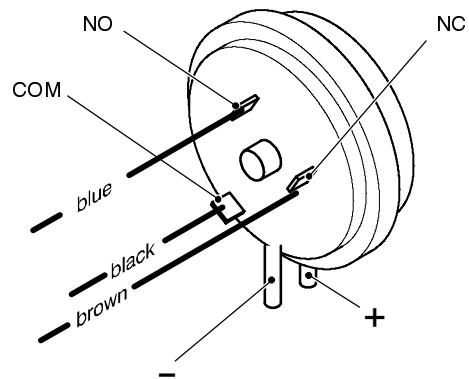

fig. 80a

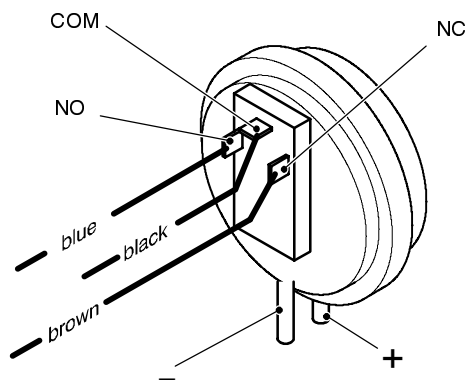

fig. 80b

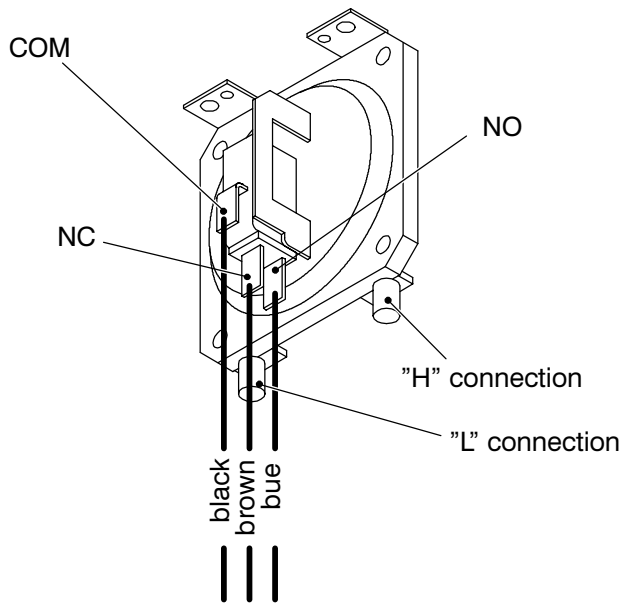

fig. 80c

18.3 Removal of the fan

Warning: isolate the boiler from the mains electricity supply before removing any covering or component.

- 1 Remove the front panel of the body and the lid of the sealed chamber;
- 2 disconnect the connectors *A* and the earth connection *B* (fig. 79);
- 3 disconnect pipes which connect the venturi device to the air pressure switch;
- 4 unscrew the screws *C* and extract it from the exhaust flue duct than move it towards the front of the boiler;
- 5 remove the fan;
- 6 assemble the fan carrying out the removal operations in reverse sequence.

Warning: reassembling the fan, refer to fig. 81 to connect correctly the venturi device to the air pressure switch.

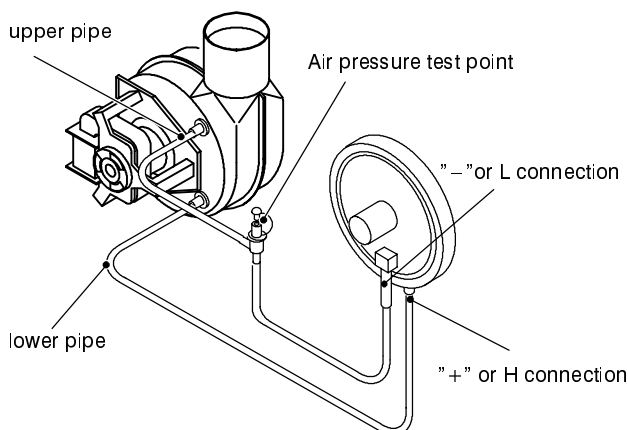

fig. 81

18.4 Removal of the air pressure switch

Note that there are two different air pressure switches with different operating values for the 424 S, 424 RS and 428 S boilers.

Refer to the short spare parts list for the correct selection of the switch.

Warning: isolate the boiler from the mains electricity supply before removing any covering or component.

- 1 Remove the front panel of the body and the lid of the sealed chamber;
- 2 Disconnect the wires of the air pressure switch;
- 3 Remove the two pipes from the air pressure switch;
- 4 Unscrew the screw *D* (two for the pressure switch of fig. 80c) which holds the air pressure switch to the frame (fig. 82);

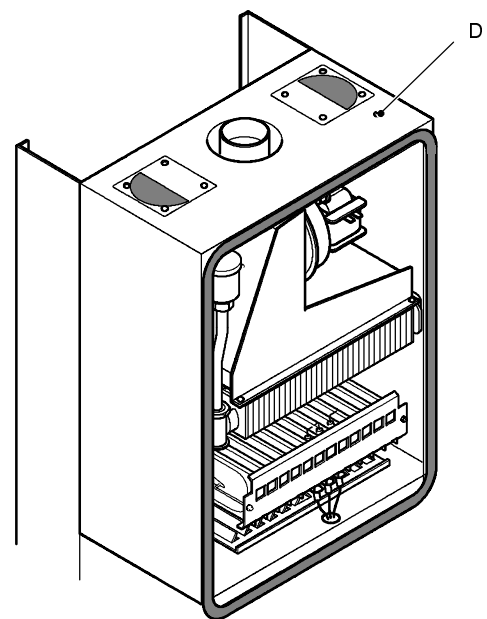

fig. 82

Warning: reassembling the air pressure switch, refer to fig. 80a b or c to connect correctly the wirings and to fig. 81 to connect the venturi device to the air pressure switch.

19 Ignition and detection electrodes

19.1 Function

Three electrodes are fitted on the burner. Two of them are the ignition electrodes and are fitted near the front part of the burner. The ignition sparks take place between their metallic edges over the central ramp of the burner during the ignition sequence.

The third electrode is the detection electrode and it detects the presence of the flame.

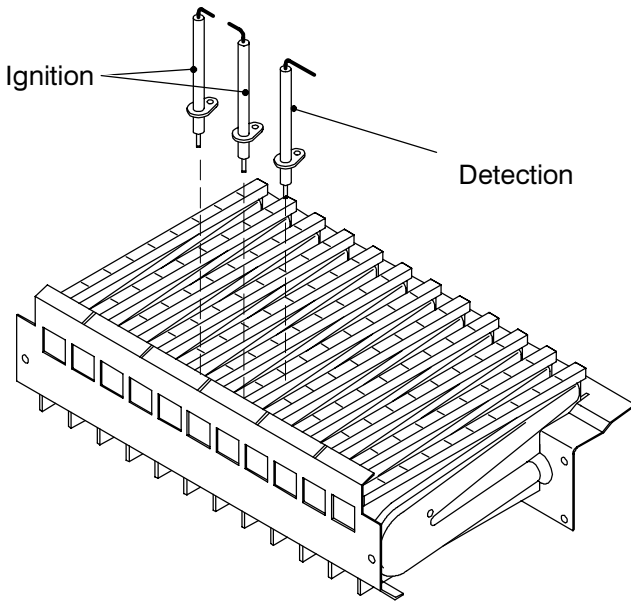

fig. 83

19.2 Checks

✓ Check the position of the electrode edges

⚡ **Warning: isolate the boiler from the mains electricity supply before removing any covering or component.**

Remove the front panel of the body, the sealed chamber cover and the combustion chamber panel.

Check for the correct distance between the metallic edges of the ignition electrodes and refer it to the fig. 84.

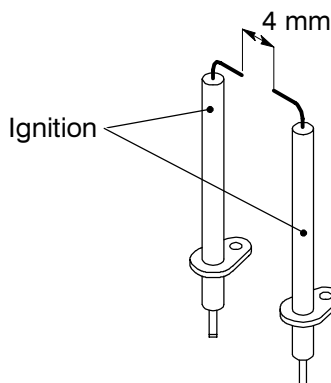

fig. 84

Check the integrity of the detection electrode and ensure that its metallic edge is correctly placed over the ramp of the burner.

✓ Check the connection wires

⚡ **Warning: isolate the boiler from the mains electricity supply before removing any covering or component.**

Remove the front panel of the body, the lid of the sealed chamber and the cover of the combustion chamber.

Check for the integrity of the insulation of wires which connect the electrodes to the ignition device.

19.3 Removal

- 1 Remove the front panel of the body, the sealed chamber lid and the combustion chamber panel.
- 2 Remove the burner unscrewing the four screws placed at the right and left sides of the burner.
- 3 Remove the grid unscrewing the two screws placed on the rear side of the burner.
- 4 Unscrew the screws A (fig. 85) which hold the electrodes to the burner.

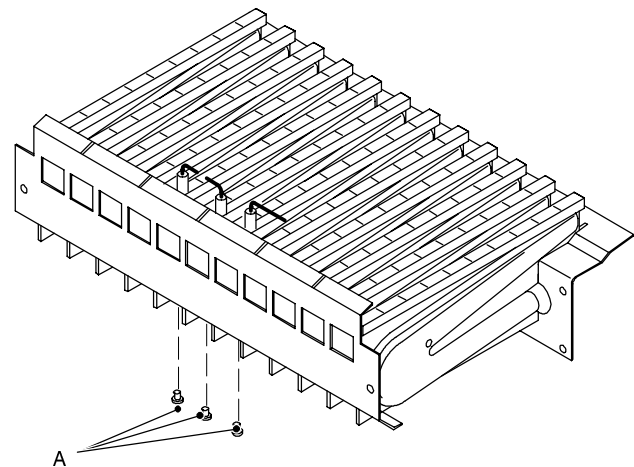

fig. 85

- 5 Extract the electrodes from the burner.
- 6 disconnect the electrode wires from the full sequence ignition device.
- 7 Assemble the electrodes carrying out the removal operation in reverse order.
In order to recognize the electrodes refer to fig. 83.

Note: the metallic edge of the detection electrode is longer than the one of the ignition electrodes.

20 Safety thermostat

20.1 Function

The safety thermostat (A in fig. 86) is a device that senses the temperature of the main circuit water which flows in the outlet pipe of the main heat exchanger.

If the temperature control system of the boiler fails and the temperature of the main circuit reaches a dangerous temperature, the safety thermostat opens the electric circuit which supply the full sequence ignition device.

Consequently, the gas valve operators are no more activated and the gas flow to the burner is stopped.

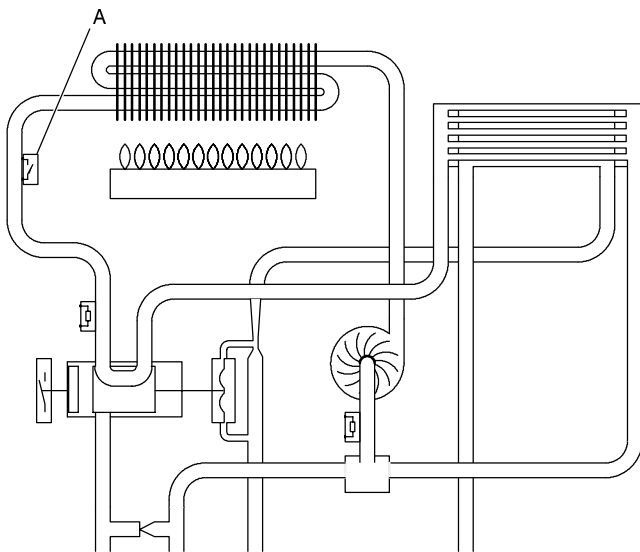

fig. 86

The safety thermostat does not re-set automatically. To reset, it is necessary to remove the plug B and push the re-set button with the help of a tool on the instrument panel (fig. 87).

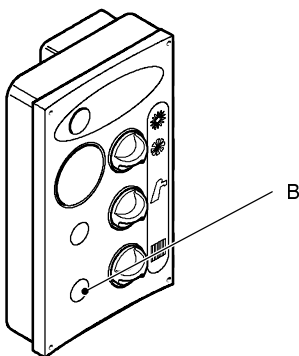

fig. 87

The safety thermostat has two parts:

- the temperature probe C which is fitted on the outlet pipe of the main heat exchanger (fig. 88)

and the electric switch D which is fitted in the control panel (fig. 89)

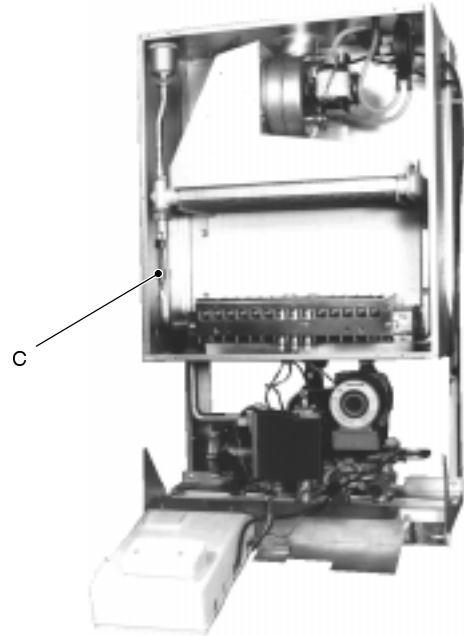

fig. 88

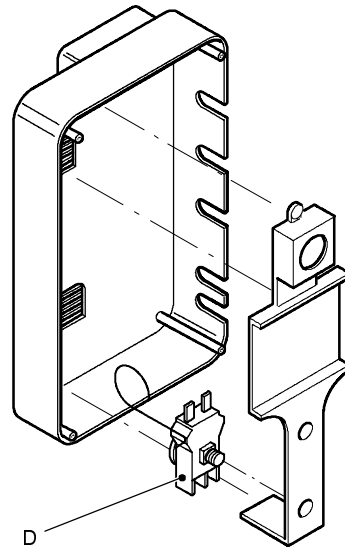

fig. 89

20.2 Checks

⚡ **Warning: isolate the boiler from the mains electricity supply before removing any covering or component.**

✓ Position of probe and integrity

Remove the front panel of the case and the sealed chamber cover.

Verify the soundness of the fitting between the main circuit pipe and the temperature probe C (fig. 88).

Verify the integrity of the capillary which connects the probe to the switch. If the capillary is broken the switch opens automatically.

✓ Overheat temperature value

Set the temperature control knobs to their max. position and run the boiler in d.h.w. and c/h. Allow the boiler to

reach its maximum operating temperature (monitor the temperature display on the control panel). The boiler should operate and maintain a temperature below that of the safety thermostat and no overheat intervention should occur.

It is not permissible to change the factory setting of the safety thermostat. The safety thermostat must be replaced if its operation temperature is too low and therefore constantly interrupts the correct functioning of the boiler and not allowing it to reach its maximum permissible operating temperatures.

✓ Electrical function

Remove the cover of the control panel as described in the section 2.3.

Disconnect the switch and check its electrical function. Normally (no intervention) the contact must be closed (electrical resistance zero Ω).

20.3 Removal

- 1 Remove the front panel of the case and the sealed chamber cover;
- 2 remove the springs which hold the temperature probe and extract the probe from the sealed chamber;
- 3 remove the cover of the control panel as described in the section 2.3;

- 4 disconnect the switch;
- 5 unscrew the nut that holds the switch to the bracket *E* and remove the thermostat;
- 6 reassemble the switch carrying out the operations in reverse order.

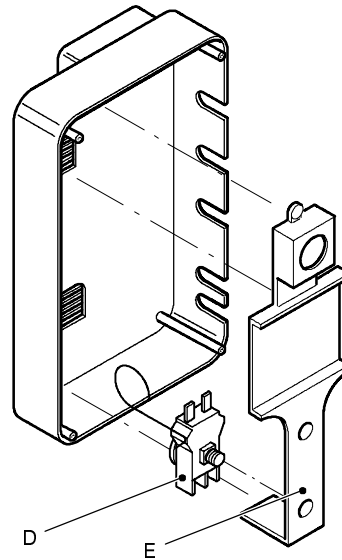
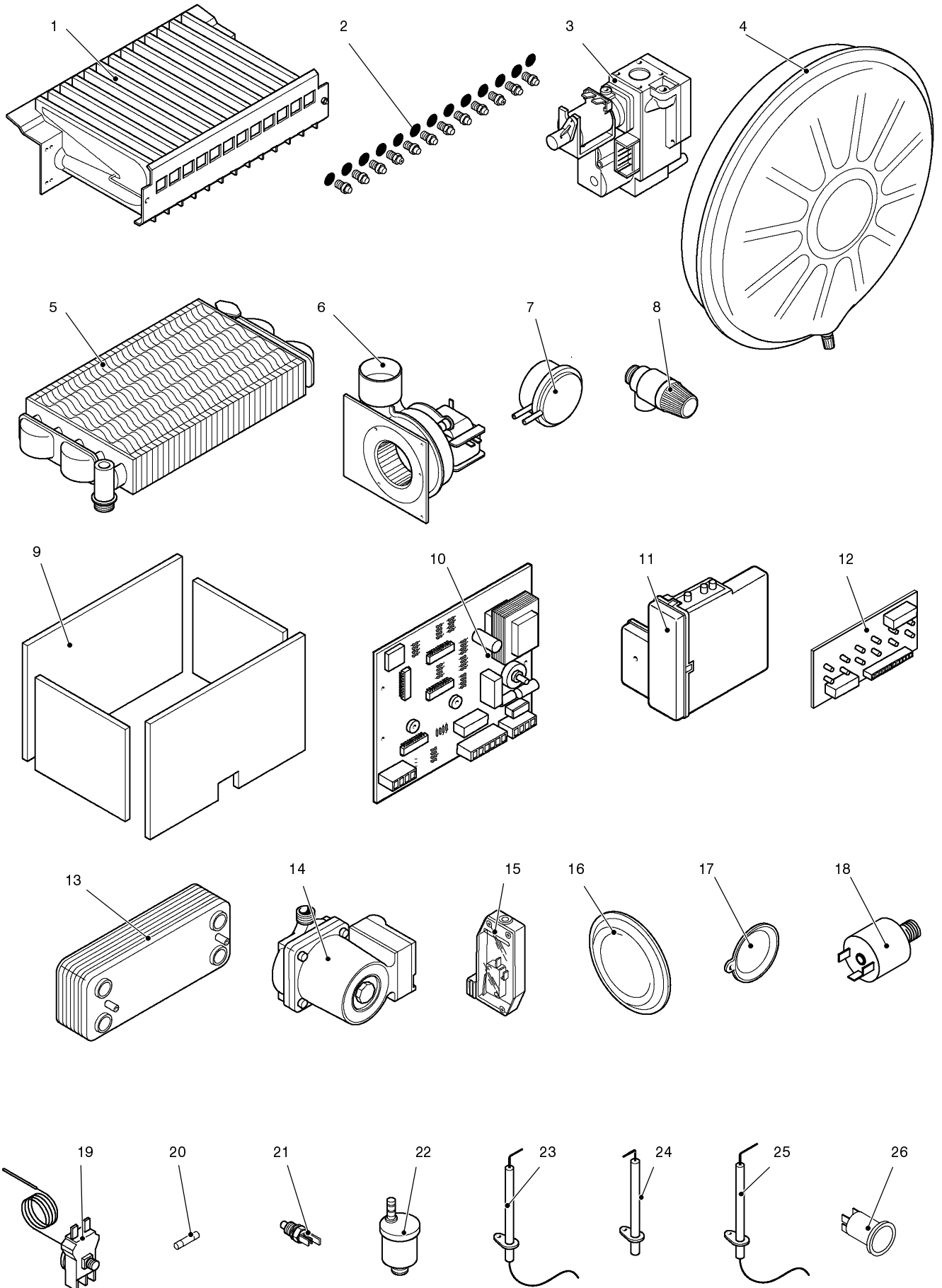

fig. 90

21 Short spare parts list

Key	G.C. part no.	Description	Q.ty	Manufac- turer part no.	Manufacturer's reference
1	E01 167	13 ramps burner (mod. 424)	1	BG1003 101	Polidoro
	E01 224	15 ramps burner (mod. 428)	1	BG1013 105	
2	E01 155	Injectors for natural	15	BG1013 502	
	E01 156	Injectors for LPG	15	BG1013 501	
3	E01 161	Gas valve	1	BG1013 108	Honeywell VK4105 M 2014
4	E00 690	Expansion vessel	1	BG1012 110	Zilmet 305008
5	E00 691	Main heat exchanger (mod. 424)	1	BG1002 102	
	E01 218	Main heat exchanger (mod. 428)	1	BG1002 103	
6	E01 199	Fan (mod. 424)	1	BG1016 108	LN Natalini A30 CO009
	E01 240	Fan (mod. 428)	1	BG1016 109	LN Natalini B25 CO009
7		Air pressure switch (mod. 424)	1		LN Natalini Type M 1,4 mbar Honeywell C6065 1,4 mbar*
		Air pressure switch (mod. 428)	1		LN Natalini Type M 1,6 mbar Honeywell C6065 1,6 mbar*
8	379 085	Safety valve	1	BG1001 112	Caleffi 512 1/2"
9	E01 189	Combustion chamber panels (mod. 424)	1	BG1006 503	
	E01 234	Combustion chamber panels (mod. 428)	1	BG1006 502	
10	E01 175	Electronic regulation p.c.b.	1	BG1015 108	
11	E01 172	Full sequence control device	1	BG1015 501	Honeywell S4565DD
12		Display circuit board	1		
13	E01 204	D.h.w. heat exchanger (mod. 424)	1	BG1001 101	
	E01 205	D.h.w. heat exchanger (mod. 428)	1	BG1001 102	
14	114 988	Pump	1	BG1002 101	Myson CP53 Salmson MYE 30-15 C-H*
	E00 699	Pump (high head)	1	BG1901 104	Myson CP63 Salmson MYL 50-15 CH3-K*
15	E00 684	Flow switch (main or d.h.w. circuit)	1	BG1011 105	
16	E01 217	D.h.w. flow switch membrane	1	BG1011 102	
17	E00 688	Main. flow switch membrane	1	BG1011 103	
18		High limit water pressure switch (2 bar)	1	BI1001 121	Ceme SpA 5612 1/4"
		Low limit water pressure switch (0,5 bar)	1	BI1001 122	Ceme SpA 5612 1/4"
19	379 086	Overheat thermostat	1	BG1015 111	Firt STB/901
20	169 083	Fuse 1,6 A T	1	BG1005 105	
21	164 026	Temperature probe (main or d.h.w. circuit)	1	BG1001 117	
22	E01 042	Automatic air release valve	1	BG1002 111	Caleffi 502040 Minical
23	E01 164	Ignition electrode (left)	1	BG1013 104	
24	E01 165	Ignition electrode (right)	1	BG1013 103	
25	E01 166	Detection electrode	1	BG1013 102	
26		Reset button / lock-out lamp	1		

* alternative





17962.0682.1 9807 (12A3)