

# BAXI BERMUDA

## SP / VP

### FIRESIDE GAS CENTRAL HEATING UNITS

Supplied by [freeboilermanuals.com](http://freeboilermanuals.com)

#### INSTALLATION & SERVICING INSTRUCTIONS FOR NATURAL GAS & PROPANE

These fires may be used with :- Bermuda 401

Bermuda 552  
Bermuda 552 Propane

#### **BAXI BERMUDA SP**

G.C. N° 37 077 18

#### **RENEWAL**

G.C.N° 156 099

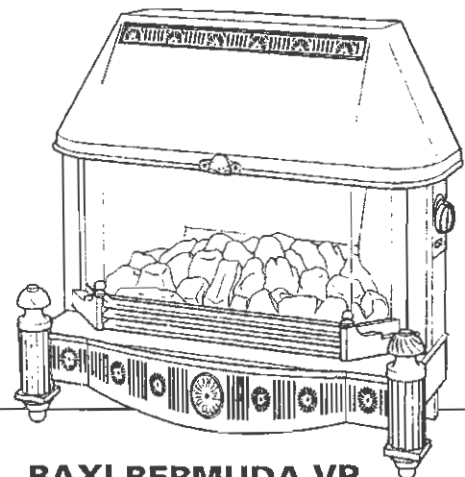

#### **BAXI BERMUDA VP**

G.C. N° 37 077 17

#### **RENEWAL**

G.C.N° 156 099

Please leave these  
Instructions with the User

These instructions must be read in  
conjunction with the separate  
instructions for the boiler section.

**BAXI**  
HEATING

# CONTENTS

**Introduction**  
**Technical Data**  
**Site Requirements**

PAGE 3

PAGE 4

PAGE 5

Fireplace Opening  
Hearth Mounting  
Wall Fixing

PAGE 6-11

**Installation**

Initial Preparation  
Electrical Connections  
Gas Supply  
Fitting the Fire

PAGE 12-14

**Commissioning the Fire**

Spillage Detection

PAGE 15-16

**Fitting the Outer Case**

Bermuda VP  
Bermuda SP

PAGE 17-21

**Annual Servicing**

Cleaning the Electrode Assembly  
Cleaning the Burner/Injectors

PAGE 22-30

**Changing Components**

Glass Frame  
Frame Sealing Rope  
Coal Bed  
Electrode  
Burners and Injectors  
Light Switch  
Electrode Lead  
Spark Generator  
Resistor  
Thermocouple  
Electro-Magnetic Unit  
Control Tap and Micro-switch

PAGE 31

PAGE 32-33

PAGE 34

**Short Parts List**  
**Fault Finding**  
**Propane**

Supplementary Instructions  
Burner Removal  
Burner Replacement

PAGE 35-39

**Renewal Firefront**

Supplementary Kit Instructions  
Existing Fire  
Boiler Adaptation  
Bermuda Boiler Fault Finding Chart

# INTRODUCTION

## Description

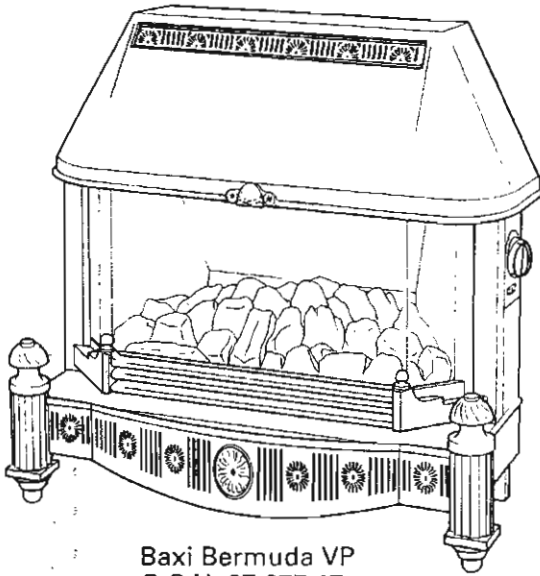

Baxi Bermuda VP  
G.C.N° 37 077 17

The Baxi Bermuda VP and Baxi Bermuda SP are combined gas fired central heating boiler and gas fire units, designed for installation in a living room. These boilers and fires are designed to be used on Natural Gas (For propane see page 34).

The heat input of both fires at their maximum setting are 5.74kW (19,600 Btu/h) with an output of 3.52kW (12,000 Btu/h). Electronic ignition is provided to light the main burner. The fires are controlled by a control knob positioned on the right hand side of the case.

This control knob has five positions giving a choice of four output settings.

- Position 0 - OFF
- Position 1 - IGNITION/LOW
- Position 2 - MEDIUM
- Position 3 - MEDIUM/HIGH
- Position 4 - HIGH

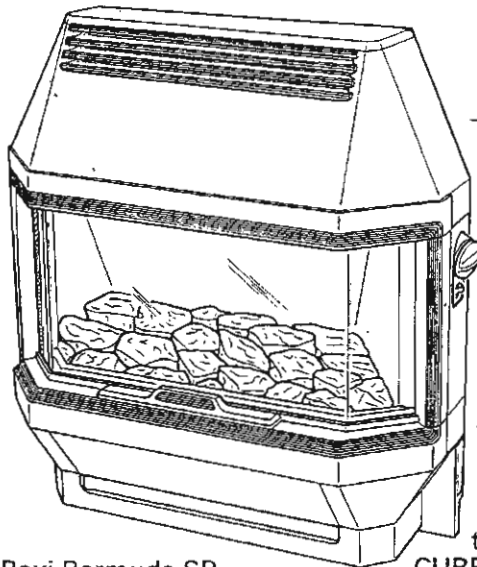

Baxi Bermuda SP  
G.C.N° 37 077 18

The artificial coal bed may be illuminated by concealed bulbs as and when required. The light effect is operated by a switch situated below the control knob. It may be used whether the fires are ON or OFF.

## Installation

The installation must be carried out by a competent person and be in accordance with the relevant requirements of the GAS SAFETY (Installation and Use) REGULATIONS 1984, the BUILDING REGULATIONS (Scotland) (Consolidation), the LOCAL BUILDING REGULATIONS, the CURRENT I.E.E. WIRING REGULATIONS and bye laws of the LOCAL WATER UNDERTAKING. It should also be in accordance with the relevant BRITISH STANDARD CODES OF PRACTICE.

## B.S. Codes of Practice

STANDARD	SCOPE
B.S. 6891:1988	Gas Installation.
B.S. 5546	Installation of hot water supplies for domestic purposes.
B.S. 5871: 1980	Installation of gas fires, convectors and fire/back boilers.
B.S. 5440: Part 1	Flues.
B.S. 5440: Part 2	Air Supply.
B.S. 6798	Installation of gas fired hot water boilers.
B.S. 5449: Part 1	Forced circulation hot water systems.

## WARNING

The addition of anything that may interfere with the normal operation of the appliance (e.g. FLUE DAMPERS, ECONOMISERS etc.) without the express written permission of BAXI could invalidate the appliance warranty and infringe the GAS SAFETY (Installation and Use) REGULATIONS 1984.

## NOTICE

### DISCOLORATION OF WALL SURFACES

Most heating appliances generate warm air convection currents and transfer heat to any wall surface against which they are situated.

Some soft furnishings (such as blown vinyl wallpapers) may not be suitable for use where they are subject to temperatures above normal room levels and the manufacturer's advice should be sought before using this type of wall covering adjacent to any heating appliance.

The likelihood of wall staining from convected air currents will be increased in environments where high levels of cigarette smoke or other contaminants exist.

# TECHNICAL DATA

## Bermuda VP (Natural Gas)

<b>Heat Input</b>	High	Med-High
kW	5.74	4.95
Btu/h	19,600	16,900

<b>Heat Input</b>	Med	Low
kW	3.43	1.96
Btu/h	11,700	6,700

<b>Heat Output</b>	High
kW	3.52
Btu/h	12,000

<b>Setting Pressure</b>	Cold
mbar	11.3 ± 0.5
in wg	4.5 ± 0.2

<b>Thermocouple Output</b>	9.5 - 10mv
----------------------------	------------

**Gas Connection** The gas supply is provided from the service cock on the boiler unit.

**Electricity Supply** 240V~50Hz 3A 120W  
External fuse - 3A

**Controls** Rotary gas tap with flame sensing device.  
Electronic ignition.

**Gas Rate (after 10 mins)** 0.57m<sup>3</sup>/h  
(20.19ft<sup>3</sup>/h)

**Lifting Weight** 27.5 kg (60.6 lbs)

**Outercase Dimensions**

Height	689mm
Width	703mm
Depth	337mm

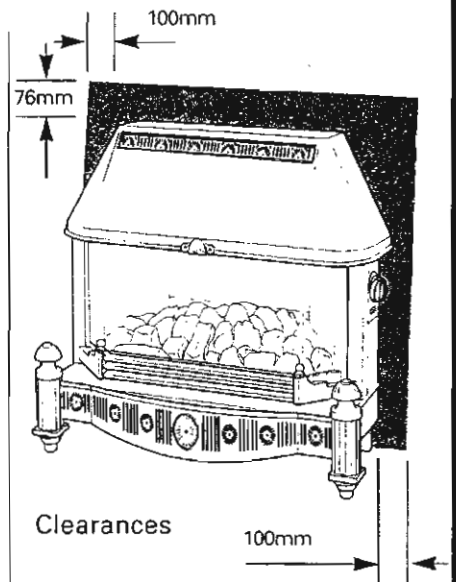

## Bermuda SP (Natural Gas)

<b>Heat Input</b>	High	Med-High
kW	5.74	4.95
Btu/h	19,600	16,900

<b>Heat Input</b>	Med	Low
kW	3.43	1.93
Btu/h	11,700	6,700

<b>Heat Output</b>	High
kW	3.52
Btu/h	12,000

<b>Setting Pressure</b>	Cold
mbar	11.3 ± 0.5
in wg	4.5 ± 0.2

<b>Thermocouple Output</b>	9.5 - 10mv
----------------------------	------------

**Gas Connection** The gas supply is provided from the service cock on the boiler unit.

**Electricity Supply** 240V~50Hz 3A 120W  
External fuse - 3A

**Controls** Rotary gas tap with flame sensing device.  
Electronic ignition.

**Gas Rate (after 10 mins)** 0.57m<sup>3</sup>/h  
(20.19ft<sup>3</sup>/h)

**Lifting Weight** 27.5 kg (60.6 lbs)

**Outercase Dimensions**

Height	689mm
Width	680mm
Depth	323mm

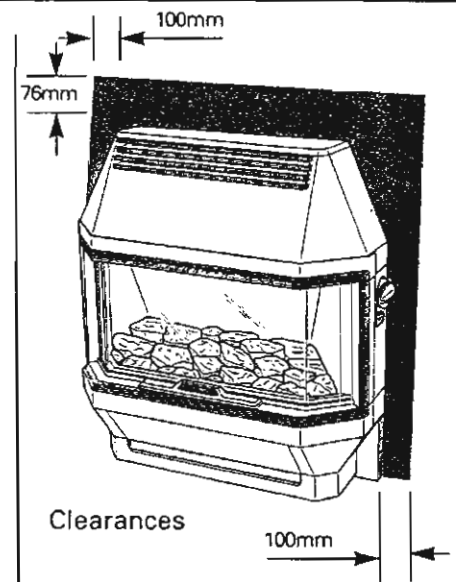

FOR PROPANE TECHNICAL DATA SEE PAGE 34.

# SITE REQUIREMENTS



## Fireplace Opening

The principal site requirements are determined by the boiler unit, but the following details are essential for the correct installation of the fire unit:

Fireplace Opening:    Height: 560mm (22in)  
                                  Width: 406mm (16in) min  
                                                     508mm (20in) max

**NOTE:** Where possible the fireplace opening should be made to the maximum width i.e. 508mm (20in). The wall behind the fire must be non-combustible.

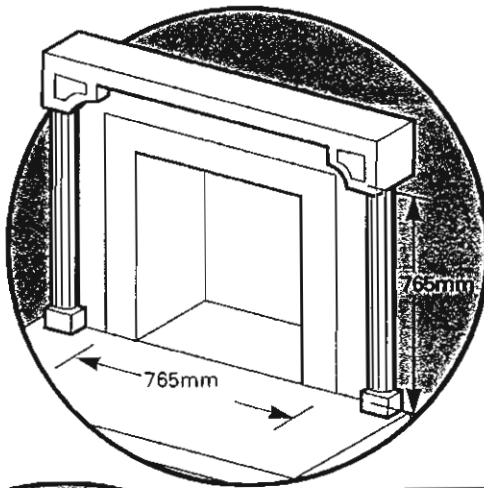

If a fire surround is to be used, its rear section must be non-combustible and have a flat vertical surface, centrally fixed about the opening measuring a minimum of 765mm (30<sup>3</sup>/<sub>4</sub>in) high by 765mm (30<sup>3</sup>/<sub>4</sub>in) wide. Any gaps between the wall and the surround must be sealed.

## HEARTH MOUNTING

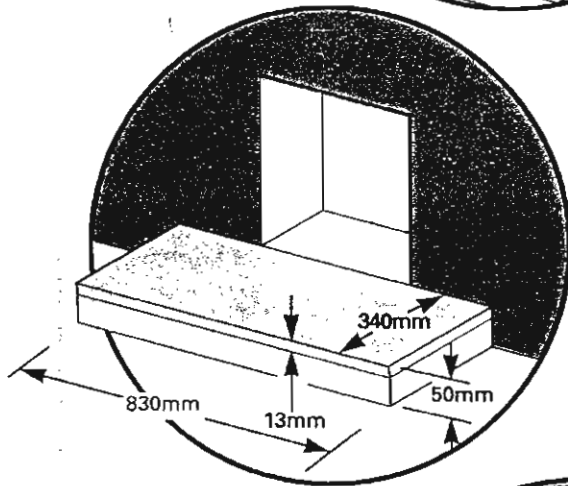

If the fire unit is to be hearth mounted then the hearth must be of a non-combustible material at least 13mm (1/2in) thick and measuring at least 340mm (13<sup>3</sup>/<sub>4</sub>in) deep by 830mm (32<sup>3</sup>/<sub>4</sub>in) wide and fitted centrally about the fireplace opening. The top surface of the hearth should be a minimum of 50mm (2in) above floor level and must be level with the base of the builders opening. **On no account should the fire unit be fitted directly onto a combustible floor or carpet.**

## WALL FIXING

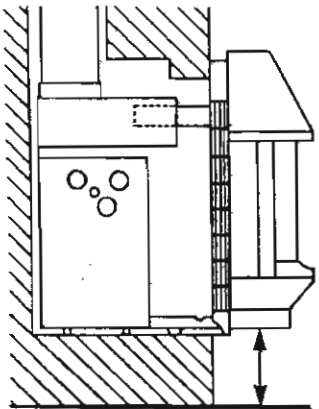

**NOTE:** Whilst the Bermuda VP is intended to be hearth mounted, it may also be fixed to a wall.

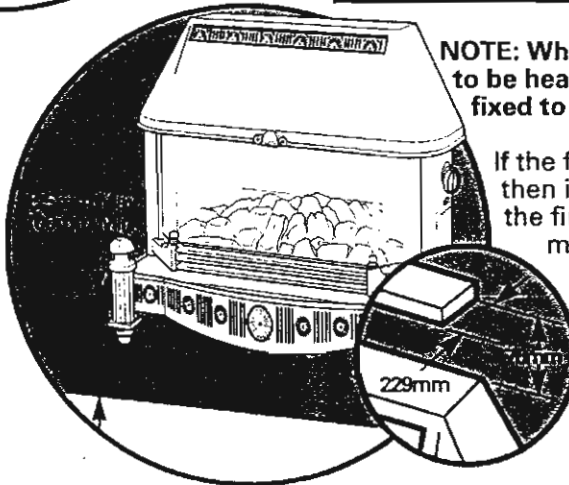

If the fire unit is to be fixed to the wall then it is strongly recommended that the fireplace opening is made to the maximum width i.e. 508mm (20in).

A shelf may be fitted above the fire unit provided that it is at least 76mm (3in) above the fire canopy and not more than 229mm (9in) in depth.

# INSTALLATION

## Initial Preparation

Unpack the fire unit by removing the polystyrene packing piece complete with fitments and placing to one side, then lift the fire from its box.

## Electrical Connections

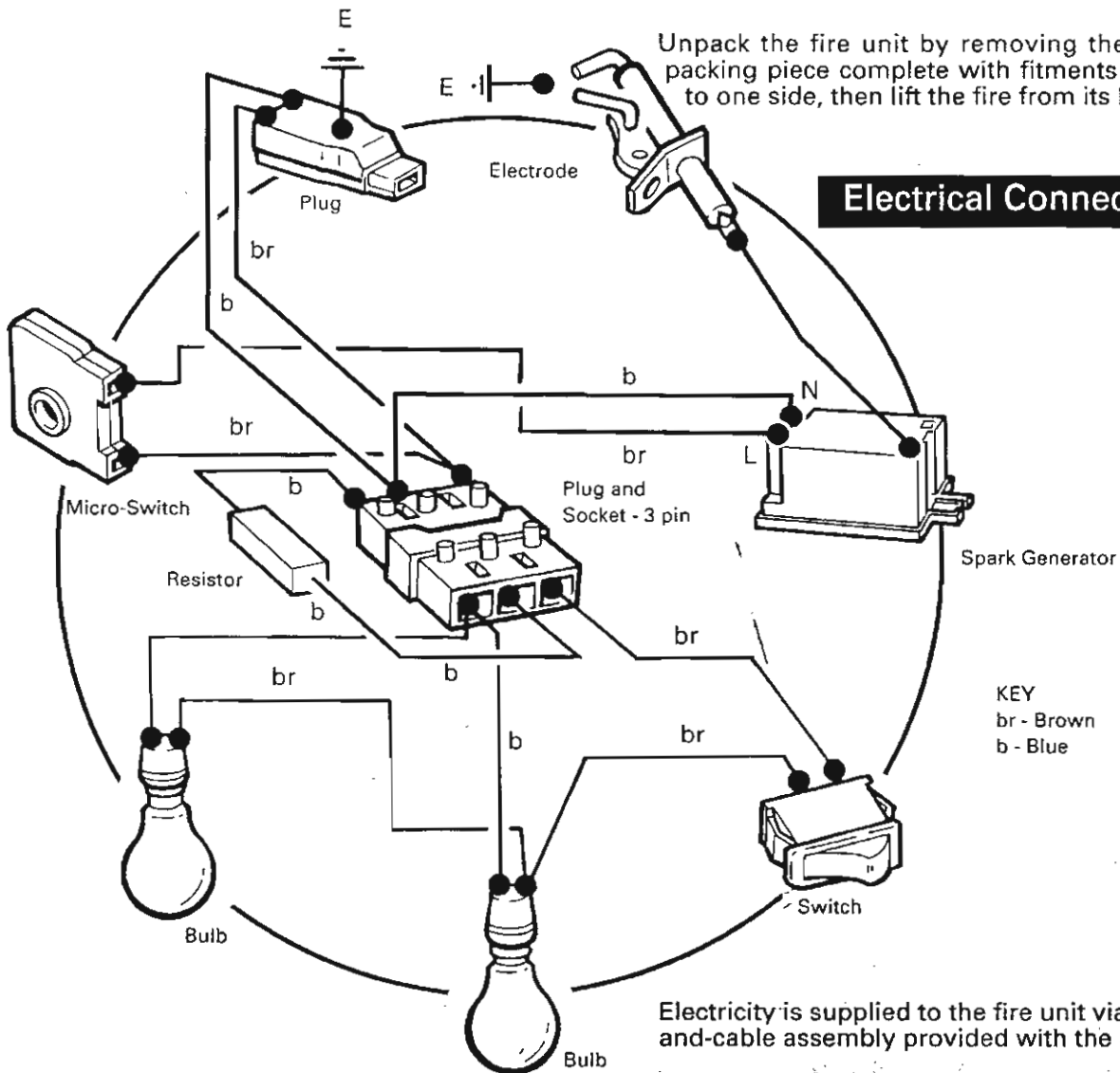

Electricity is supplied to the fire unit via the plug-and-cable assembly provided with the appliance.

The cable must be connected to the plug and socket on the boiler base. This connection should be made at the same time as the boiler electrical connections.

**NOTE:** The method of connection to the electricity supply must facilitate complete electrical isolation of the appliance. Connection may be made via a fused double pole isolator with a contact separation of at least 3mm (1/8 in) in all poles and serving the appliance and systems control only (max. fuse rating 3 amp). A permanent electricity supply to the boiler is required.

## WARNING

**THIS APPLIANCE MUST BE EARTHED.** 4 core input cable for connection to the boiler unit must NOT be less than 0.75mm<sup>2</sup> (24 x 0.2mm) PVC heat resistant to 70°C grade 1 to BS 6500 table 15 or 16.

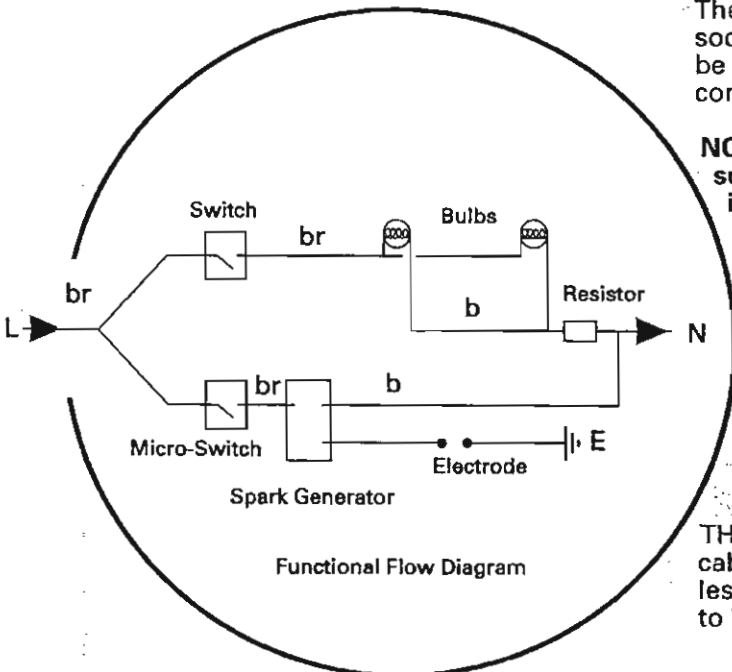

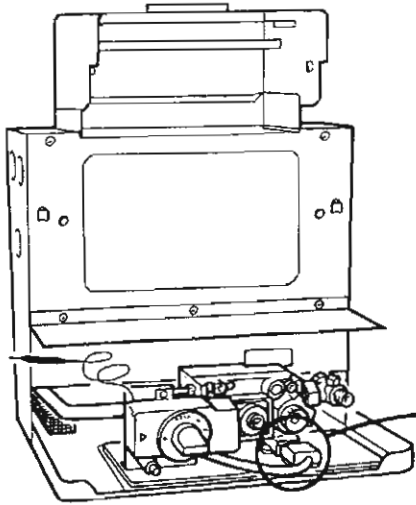

To connect the electrical wiring to the boiler unit.

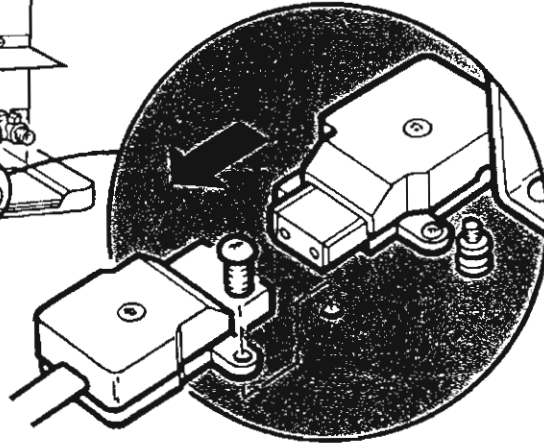

Remove the screw retaining the controls connection plug and disconnect the plug.

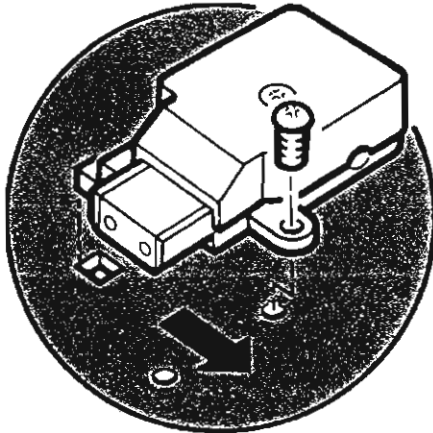

Remove the screw fixing the input socket to the boiler base. Slide the socket to the right, then lift to remove.

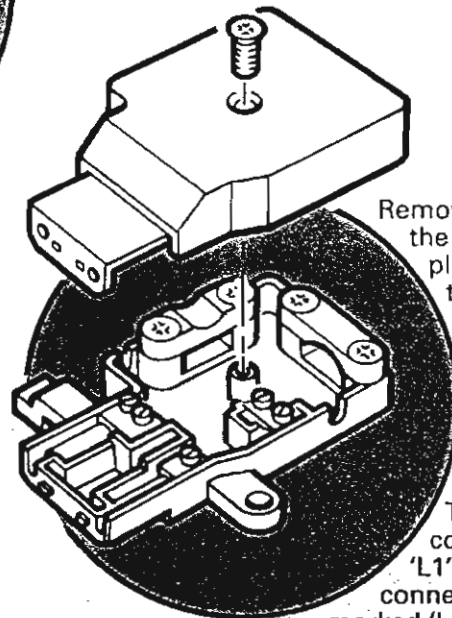

Remove the screw fixing the cover to the socket housing and remove the plastic cover, revealing the terminals and cable clamps.

Fit the supply cable to the terminals.

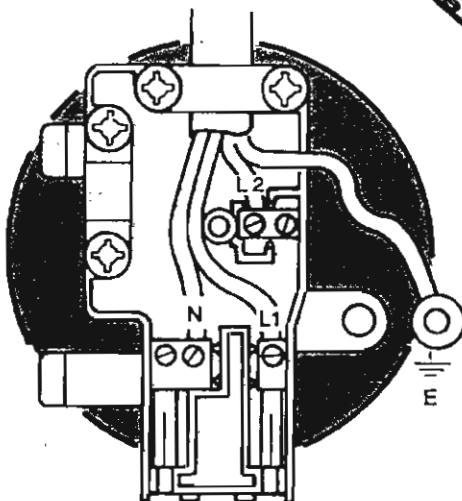

The SWITCHED LIVE must be connected to the terminal marked 'L1'. The PERMANENT LIVE must be connected to one of the terminals marked 'L2'. The NEUTRAL must be connected to one of the terminals marked 'N'. The EARTH WIRE (green & yellow) must be routed through the cut-out in the side of the socket housing and must be sufficiently long to connect the wire to the earth terminal at the boiler base. The earth wire should be long enough so that the live and neutral wires will become taut before the earth wire if the supply cable is pulled on.

Secure the cable in the socket with the cable clamp. For 3-core cable use with the flat side downwards, for 4-core cable use with the radius side downwards.

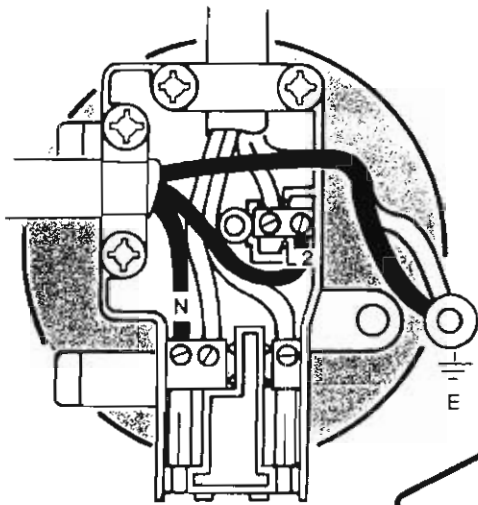

From the plug and cable connection supplied with the fire unit, the following connections should be made, making sure that the appropriate cable clamp is used to hold the cable firmly.

Connect the blue wire (neutral) to the remaining terminal marked 'N'. Connect the brown wire (permanent live) to the remaining terminal marked 'L2'. Route the green & yellow wire (earth) through the cut-out in the socket housing and connect it to the earth terminal.

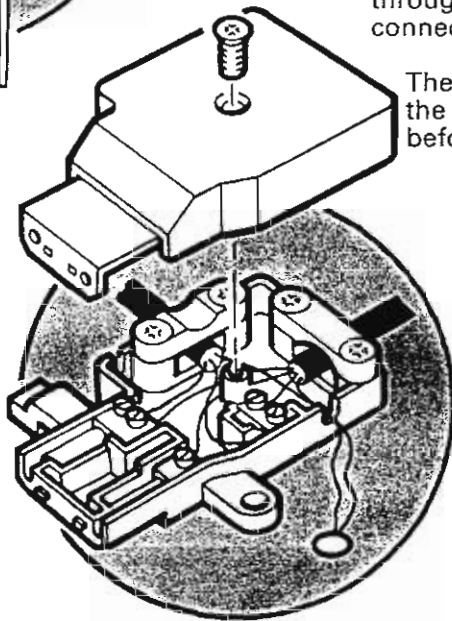

The earth wire should be long enough so that the live and neutral wires will become taut before the earth wire if the cable is pulled on.

Refit the socket cover and fix in place with the screw.

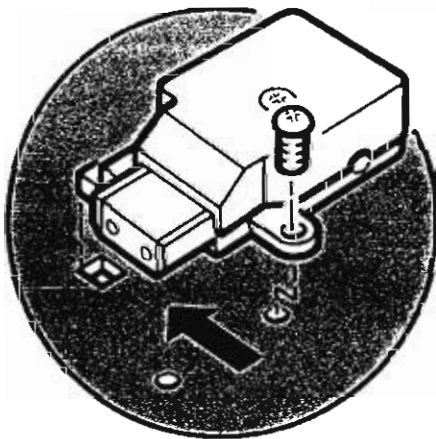

Refit the input socket assembly to the boiler base and fix in place with the securing screw.

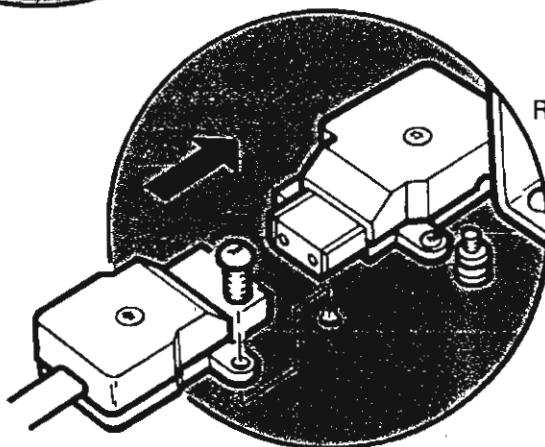

Reconnect the controls connection plug to the input socket and again, fix in place with the securing screw.

Clamp the input cable in place using the appropriate clip.



## Gas Supply

The gas installation should be in accordance with BS 6891 :1988.

The gas supply to the fire unit is provided from the service cock on the boiler using the supply pipe supplied with the unit.

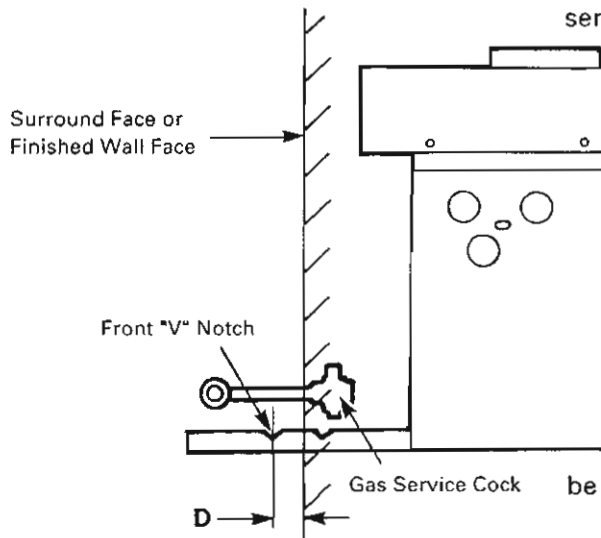

The pipe has one flared end (for connection to the fire) and a plain end (for connection to the service cock by a nut and olive).

It may be necessary to shorten the supply pipe depending upon the position of the boiler unit relative to the face of the wall or surround. If this is the case, then follow the following procedure, taking care to cut the supply pipe to the correct length.

Measure the distance from the centre of the front 'V' notch on the boiler base tray to the face of the wall or surround. Let this distance be known as distance 'D'.

Mark off distance 'D' from the plain end of the supply tube, cut and dispose of the unwanted piece of tube. Care must be taken to ensure that the cut is square and that the pipe is free from burrs and swarf.

(An alternative method of determining the length of the supply pipe is to hold the plain end flush with the face of the wall or surround and mark the pipe at the position of the front V notch on the boiler base tray).

Thread the steel flare nut over the supply pipe, then fix the plain end to the service cock on the boiler using the nut and olive. Ensure that the flared end of the pipe faces to the right and is parallel with the hearth or floor, then fully tighten.

### BOILER MODIFICATIONS

**NOTE:** It is important at this stage to fit the controls heat shield supplied with the fire unit to the boiler front panel.

Remove and discard the controls heat shield provided with the boiler and fit the new controls heat shield using the screws previously removed.

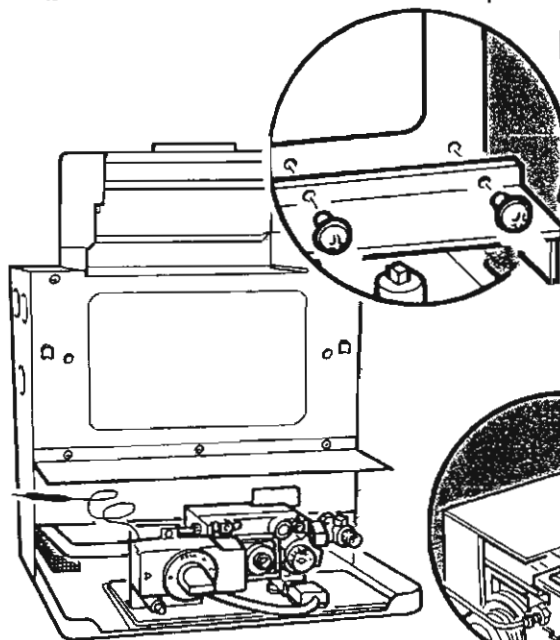

Fit the additional valve heat shield in position over the gas valve by engaging the two clips and pushing home. (As shown in the illustration.)

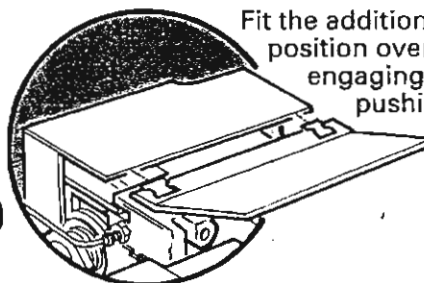

## Fitting the Fire

### HEARTH FIXING

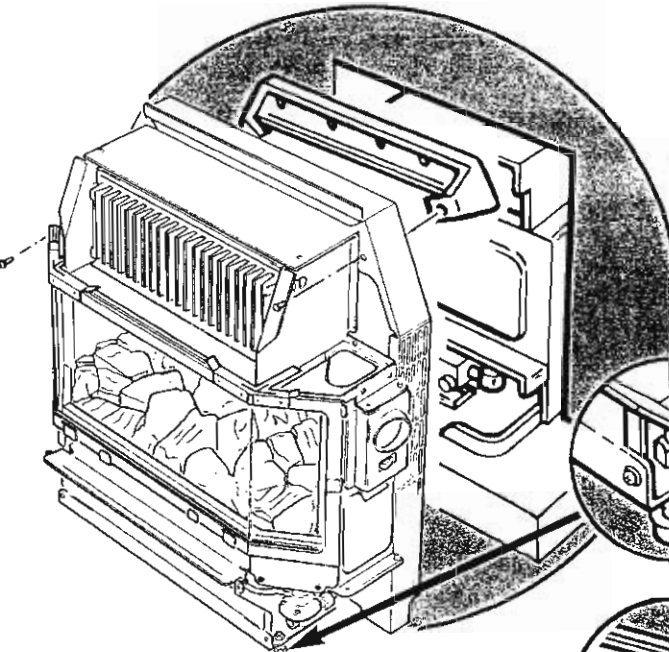

Take the backing plate and fix it to the fire unit with two of the  $\frac{5}{8}$ in screws provided. Locate the flue spigot into the down-draught diverter on the boiler unit. Push the fire backwards until the backing plate touches the surround or wall face. Ensure that the down-draught diverter bottom passes over the controls heat shield.

Level the fire by adjusting the front feet (check using a spirit level).

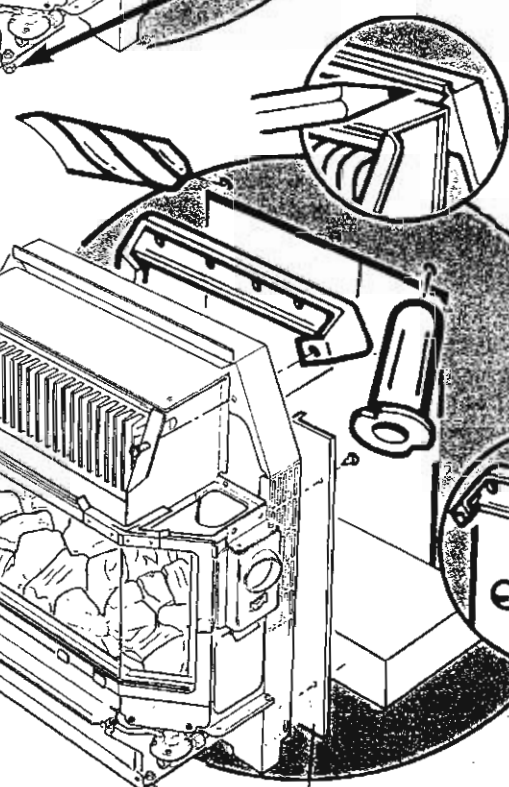

Mark the positions of two suitable fixing holes in the backing plate. **NOTE: Where possible use the top corner fixing hole positions, otherwise space the fixing holes as far apart as possible.**

Remove the fire unit from the hearth and remove the backing plate from the fire chassis by removing the two screws holding it in position. Retain the screws.

Drill the fixing holes in the surround/wall face to accept the wall plugs provided.

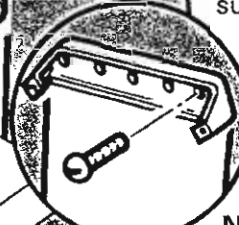

Fix the backing plate in position on the wall using the screws provided.

**NOTE: (For Bermuda SP only) Fit the two blanking plates in position using the  $\frac{3}{4}$ in screws provided.**

Blanking Plate  
(Bermuda SP only)

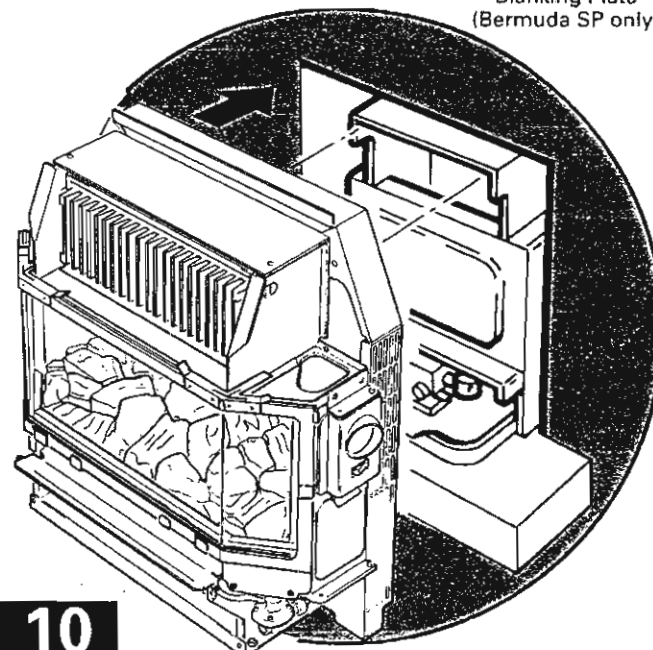

Relocate the flue spigot in the down draught diverter and push the fire backwards as far as possible. Secure the fire to the backing plate using the screws previously removed.

Connect the supply pipe to the fire inlet connection and tighten the flared joint.

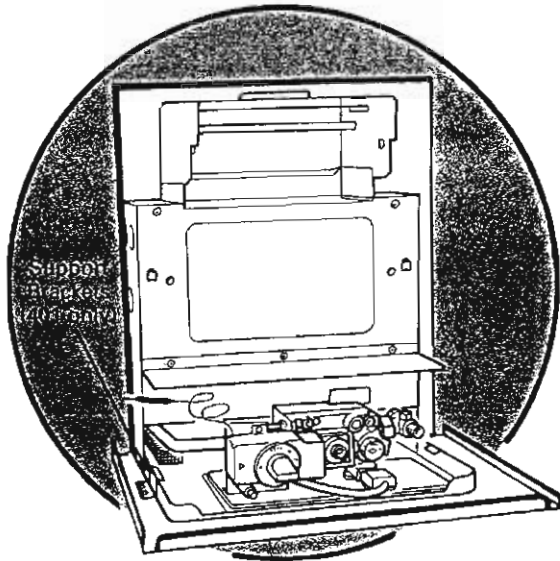

## WALL FIXING

Taking the fire support plate from the fire unit packaging, place it beneath the boiler base protruding from the fireplace opening. With the nuts, screws and washers provided, loosely attach the plate to the boiler base using the centre group of holes at each side.

**NOTE: If the fire is being used with a Bermuda 401 boiler unit, the support brackets supplied with the boiler must be fitted before the fire support plate can be fixed in place.**

Push the support plate backwards until it touches the surround/wall face and tighten the screws to lock it in position.

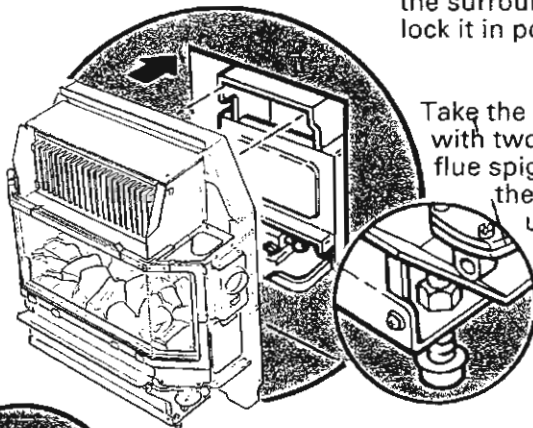

Take the backing plate and fix it to the fire unit with two of the  $\frac{5}{16}$ in screws provided. Locate the flue spigot into the down-draught diverter on the boiler unit. Push the fire backwards until the backing plate touches the surround or wall face.

Level the fire by adjusting the front feet (check using a spirit level).

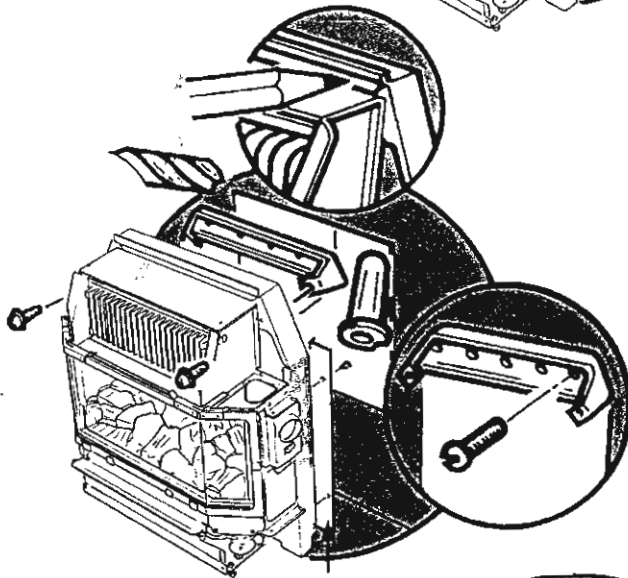

Mark the positions of the available fixing holes in the backing plate. **NOTE: Where possible use the top corner fixing hole positions, otherwise space the fixing holes as far apart as possible.**

Remove the fire unit from the support plate and remove the backing plate from the fire chassis by removing the two screws holding it in position. Retain the screws.

Drill the fixing holes in the surround/wall face to accept the wall plugs provided.

Fix the backing plate in position on the wall using the screws provided.

**NOTE: (For Bermuda SP only) Fit the two blanking plates in position using the  $\frac{3}{16}$ in screws provided.**

Blanking Plate  
(Bermuda SP only)

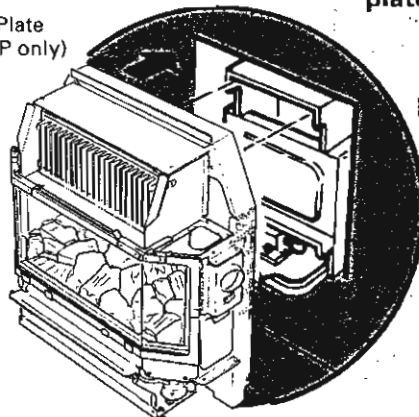

Relocate the flue spigot in the down-draught diverter and push the fire backwards as far as possible. Secure the fire to the backing plate using the screws previously removed

Connect the supply pipe to the fire inlet connection and tighten the flared joint.

# COMMISSIONING THE FIRE

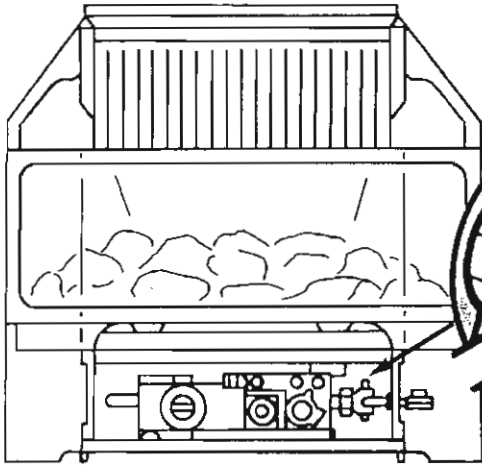

Turn the gas service cock to the boiler and fire position. Purge any air from the fire supply pipe. Check for gas soundness from the gas service cock to the fire in let connection (BS 6891: 1988).

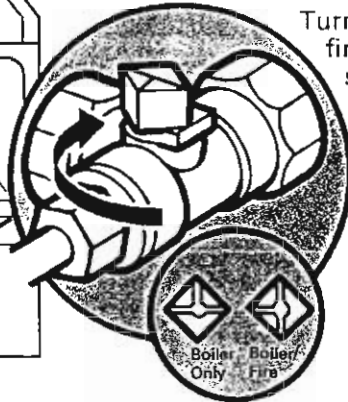

Remove the glass frame by disengaging the retaining clamps and lifting away. Remove the polystyrene packing piece securing the coal bed in position.

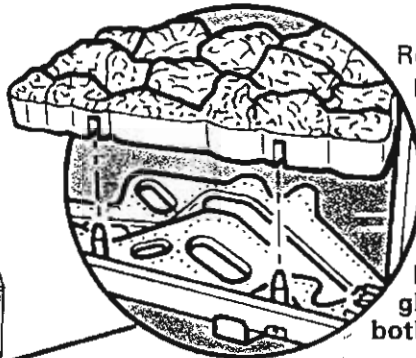
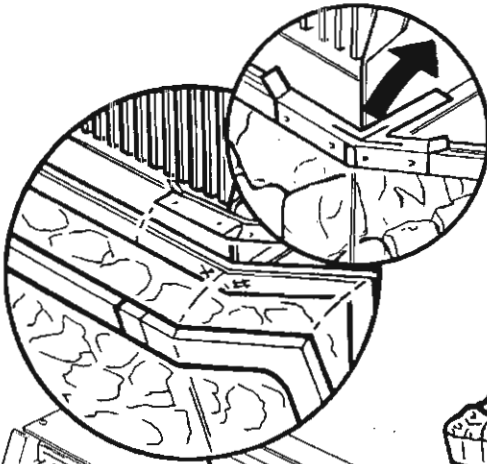

Remove the coal bed from its plastic bag and carefully replace in position on the burner.

**NOTE: The coal bed is extremely fragile and must be handled accordingly.**

Remove any labels fixed to the glass frame assembly and clean both sides of the glass panels using a cream cleanser, before replacing the glass frame.

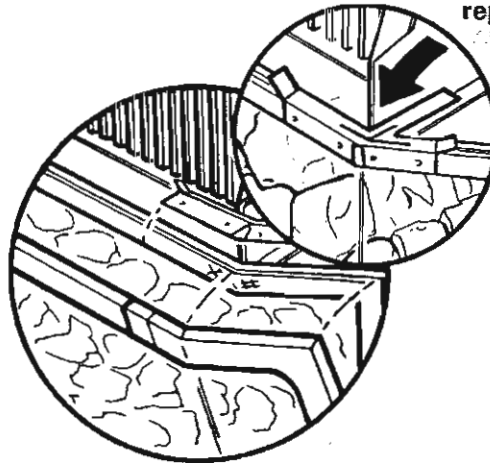

Replace the glass frame and lock in place by engaging the retaining clamps.

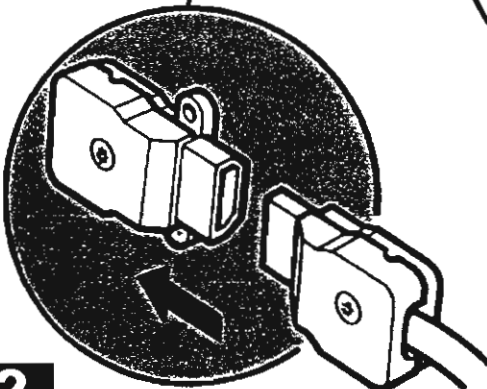

Connect to the electricity supply to the fire unit by fixing the plug in position.

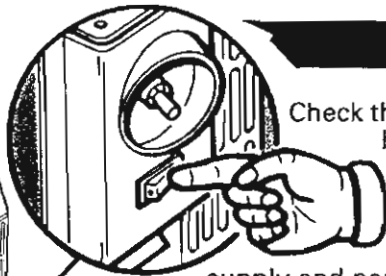
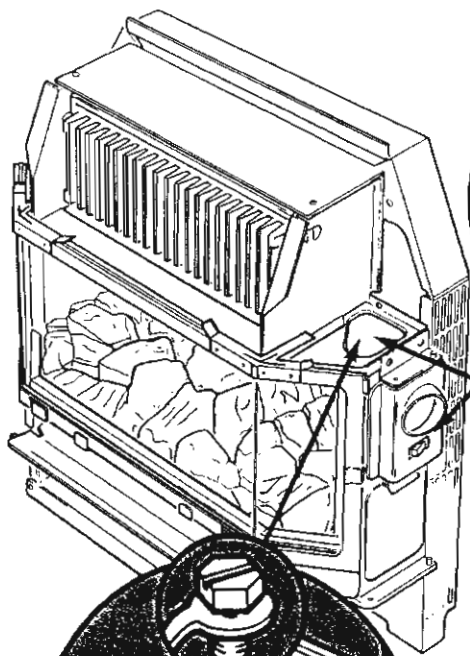

Check the electricity supply to the fire unit by switching on the illumination bulbs to the coal bed. If the bulbs light, switch off and continue with commissioning the fire. If the bulbs do not light, isolate the electricity supply and perform preliminary electrical system checks before proceeding i.e. earth continuity, polarity, resistance to earth etc.

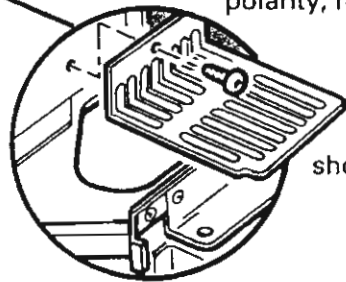

Remove the electrical cover on the right hand side of the chassis as shown, by removing the fixing screw.

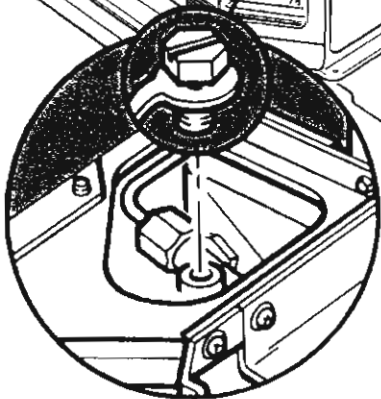

Release the pressure test point sealing screw and connect a pressure gauge in position.

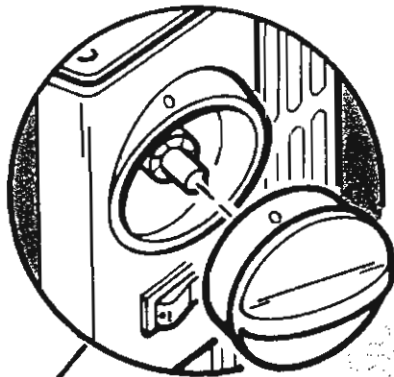

Fix the control knob to the gas control spindle.

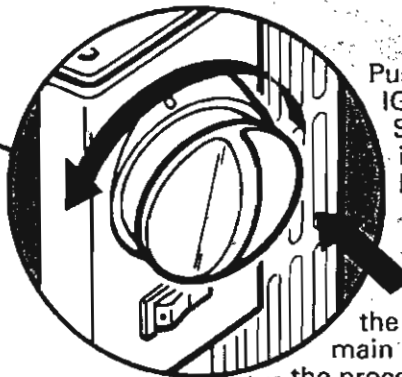

Push in the control knob, turn to the IGNITION position (⚡) and hold in. Sparking will commence at the ignition electrode and the main burner will ignite.

Continue to hold the control knob in for a further 15 seconds then release. The sparking will stop and the main burner will stay alight. If the main burner does not stay alight, repeat the process after waiting for 2 minutes. (If the burner still fails to remain alight, refer to the fault finding chart).

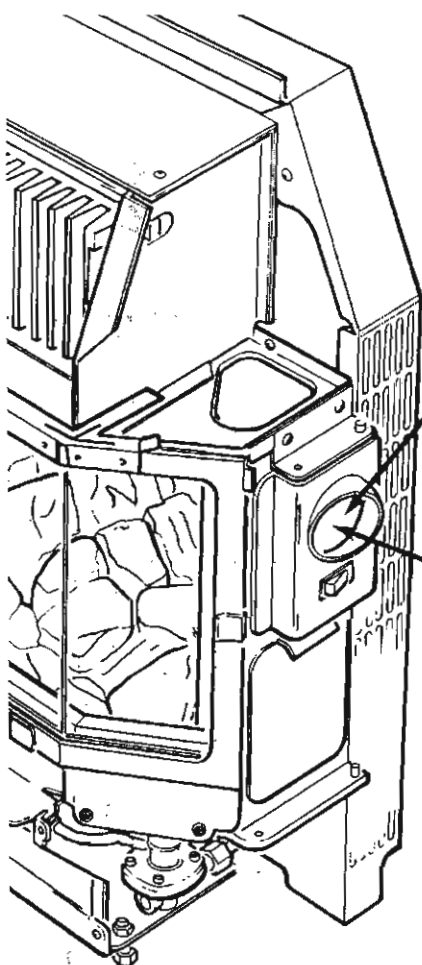

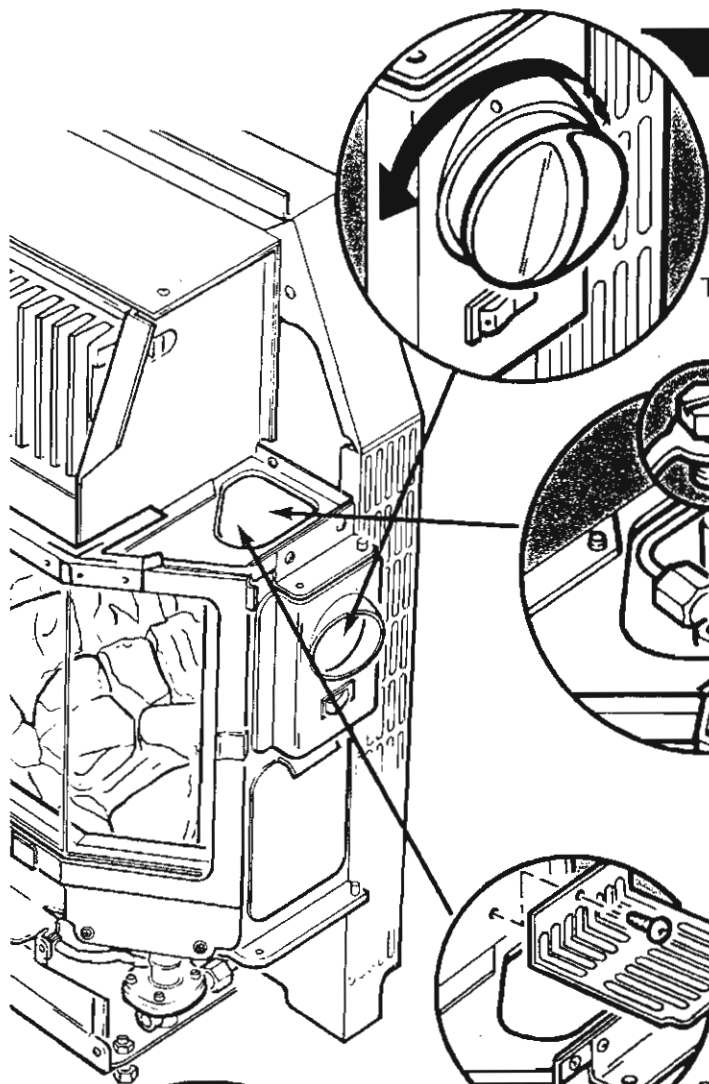

Check the setting pressure at position 4. No adjustment to the setting pressure is possible.

Turn the control knob to the 'OFF' ( O ) position.

Disconnect the pressure gauge and replace the pressure test point sealing screw, ensuring a gas-tight seal.

Refit the electrical cover.

### SPILLAGE DETECTION

A test for clearance of flue products is only possible from the left hand side and must be made as follows: Ensure that all doors and windows in the room are closed. (If there is an extractor fan in the room or any adjoining room, the check for spillage must be with the fan turned on and any interconnecting doors open.) Ignite the fire and turn to setting 4. After running for 5 minutes take a lighted smoke match and insert it into the boiler down-draught diverter as shown.

### WARNING

CARE MUST BE TAKEN TO AVOID TOUCHING HOT PANELS AT THIS POINT.

If the majority of the smoke is not drawn into the chimney, then spillage of combustion products is indicated and further investigations must be carried out.

**NOTE:** If the restrictor ring has been fitted (see boiler installation instructions), then removing this may alleviate any spillage problems.

Repeat the procedure with both the boiler and the fire alight (the boiler having been alight for 5 minutes).

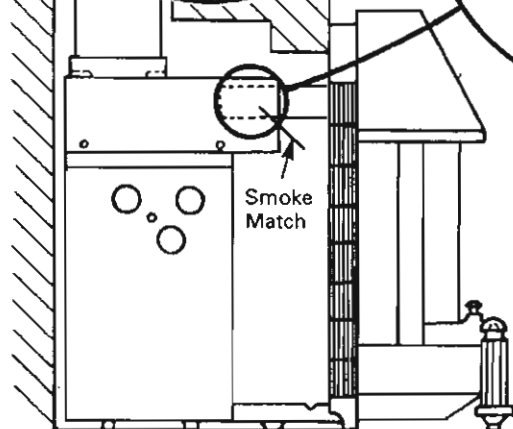
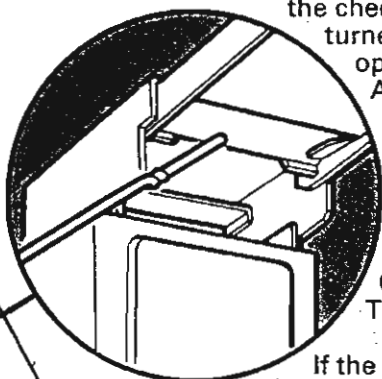
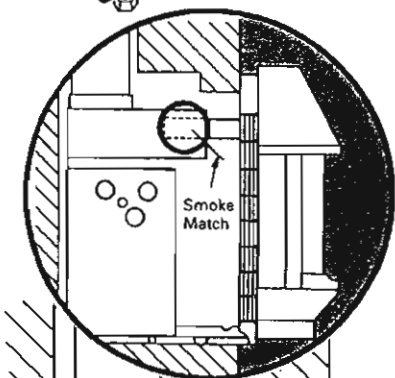

# FITTING THE OUTER CASE

## Bermuda VP

Turn off the fire and fit the outer case components as follows:

Remove the fender front from the hearth assembly by pulling forward.

Engage the hearth assembly on the side ledges as shown and push home as far as possible. Adjust the feet to touch the fireplace hearth. Fix the hearth assembly in position using the two N° 8 x 5/16 in screws in the front and the two M4 x 8mm thread former screws in the sides.

Hang the left and right hand side doors on the fittings as shown and close the doors, ensuring that they lock in position.

Fix the canopy by lowering it into position over the top edge and then by gently easing the sides inwards, push home to lock in place.

Locate the fender front in position at the front of the hearth assembly and push home.

Instruct the user in the operation of the fire controls and hand over the user's instructions and installation instructions, **giving advice on the necessity of regular servicing.**

## Bermuda SP

Turn off the fire and fit the outer case components as follows:

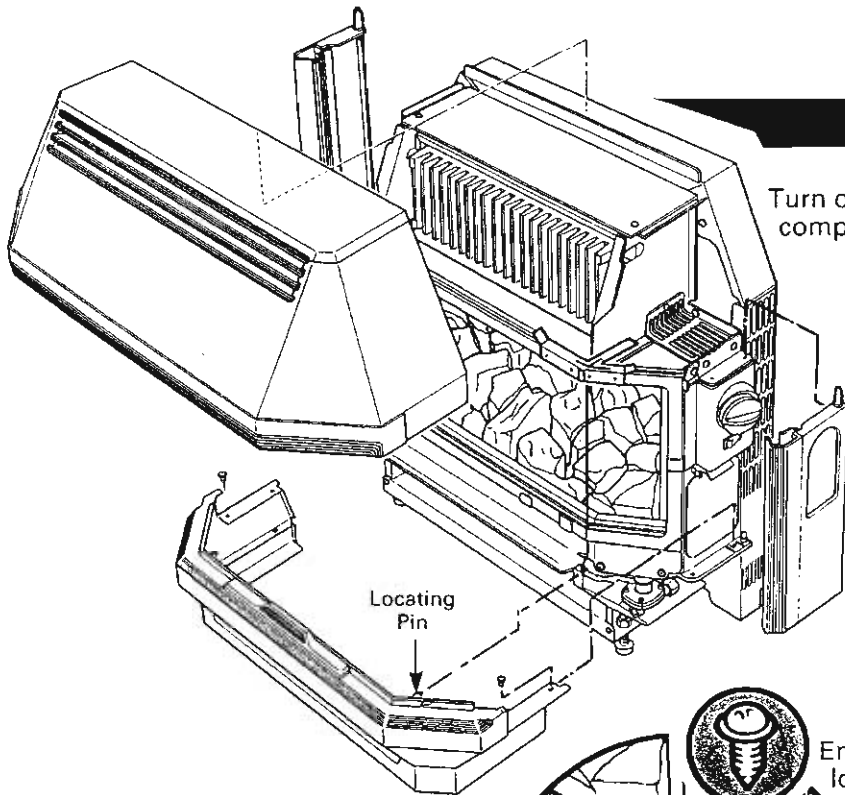

Engage the hearth by guiding the locating pins through the holes in the innercase and sliding forward on the side ledges as far as possible. Fix the hearth in position using the two  $\frac{3}{8}$  in screws in the sides.

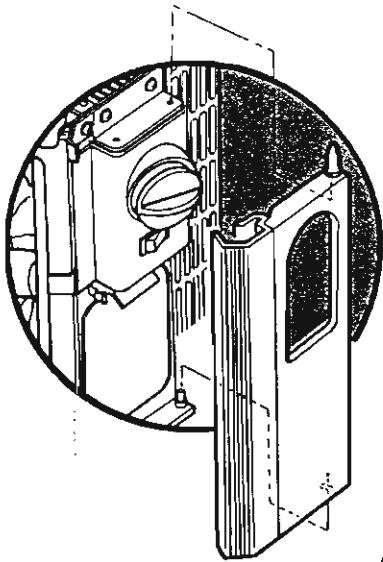

Hang the left and right hand side doors on the fittings as shown leaving them open.

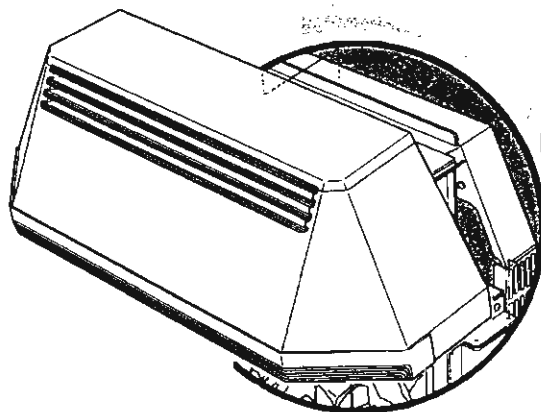

Fix the canopy by guiding the bottom edge onto the door pins and then by tilting the back edge over the locating lip on the innercase. Close the doors ensuring they lock in place.

Instruct the user in the operation of the fire controls and hand over the user's instructions and installation instructions, **giving advice on the necessity of regular servicing.**



# ANNUAL SERVICING

## Bermuda VP

For economy and safety reasons, it is important to service both the fire and boiler units annually.

**NOTE:** Before attempting to service the appliance, ensure that the fire is COLD.

**ISOLATE THE ELECTRICITY SUPPLY TO THE BOILER AND FIRE UNITS.**

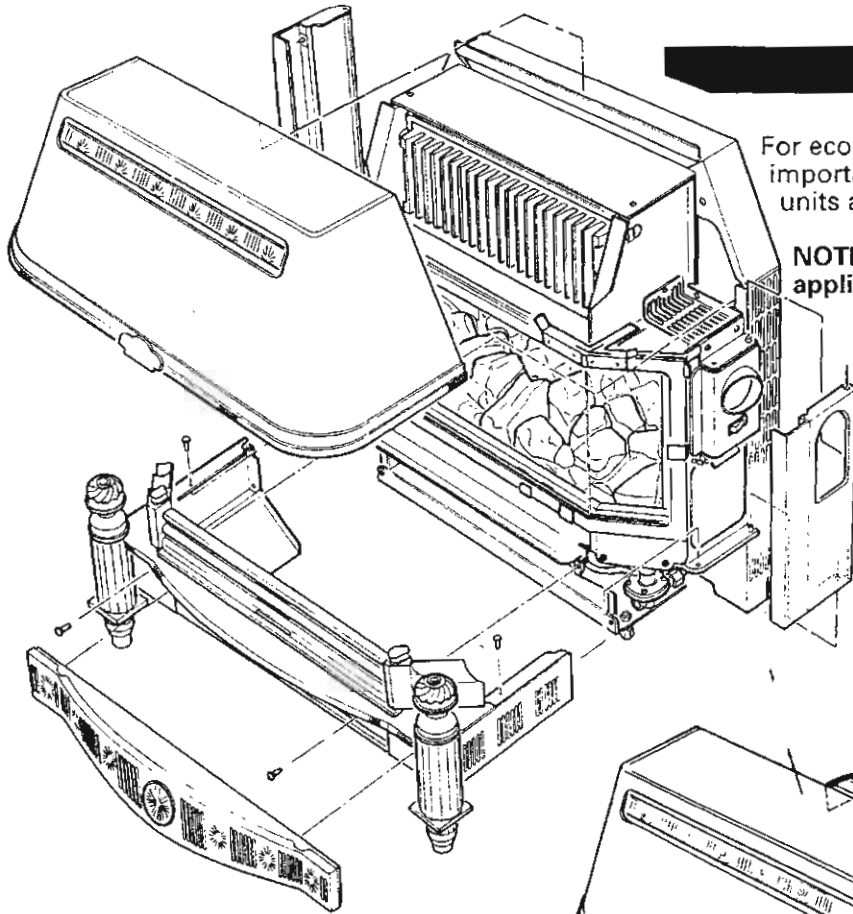

Remove the canopy by gently easing the sides inwards and pulling the bottom edge forward, then lift the canopy upwards and away from the locating lip.

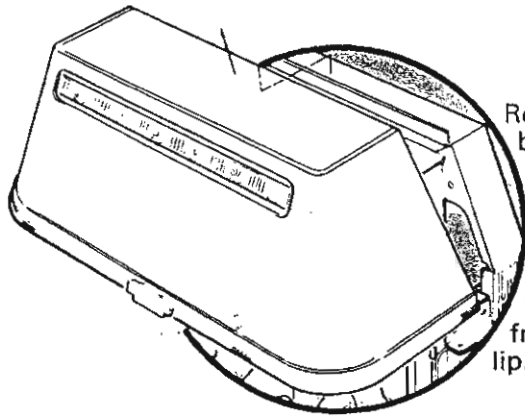

Remove the left and right hand side doors firstly by opening them and then lifting away from their mountings.

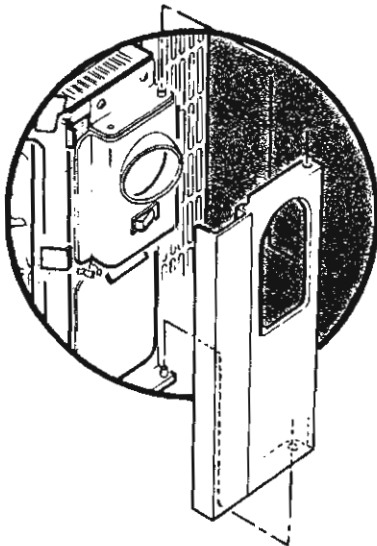

Remove the fender front by pulling forward.

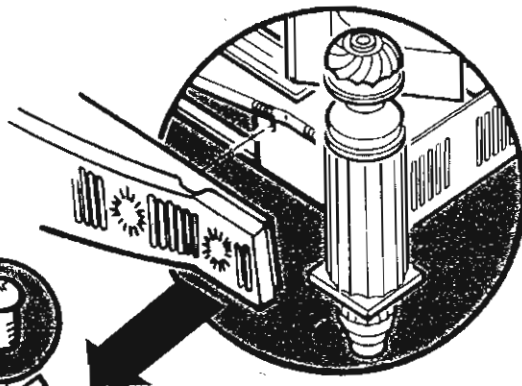

Remove the hearth assembly by removing the fixing screws and sliding it forward and away from the chassis.

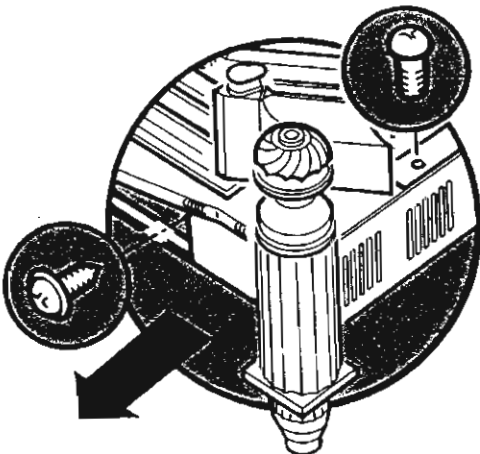

## Bermuda SP

For economy and safety reasons, it is important to service both the fire and boiler units annually.

**NOTE:** Before attempting to service the appliance, ensure that the fire is COLD.

**ISOLATE THE ELECTRICITY SUPPLY TO THE BOILER AND FIRE UNITS.**

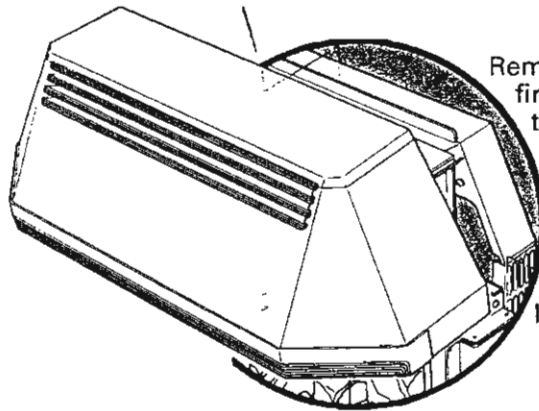
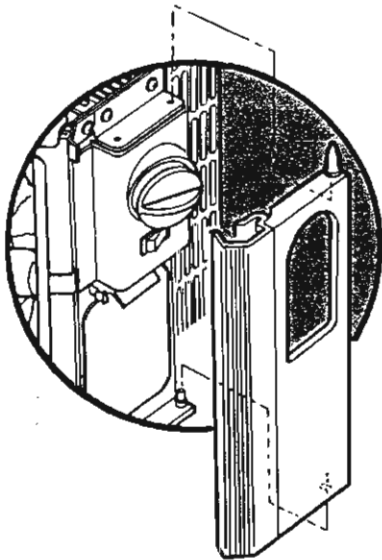
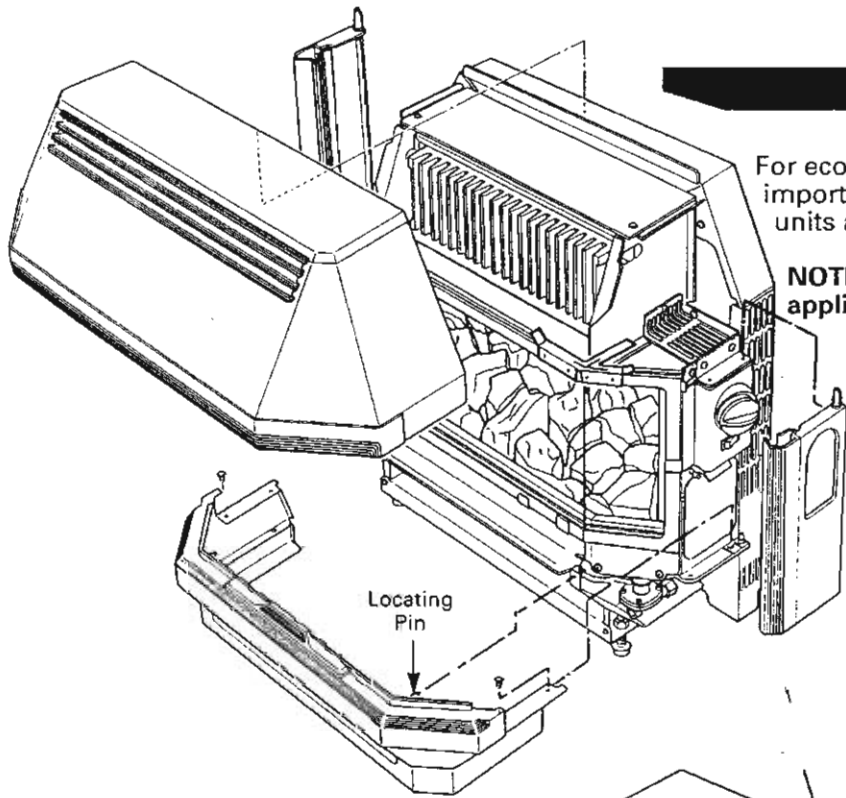

Remove the canopy, firstly by opening the left and right hand side doors, then lift the canopy by the bottom edge upwards and away from the locating lip.

Remove the left and right hand side doors by lifting away from their mountings.

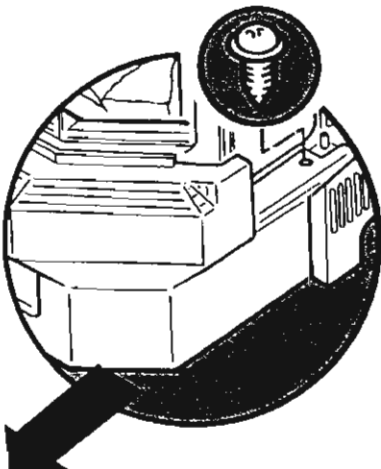

Remove the hearth by removing the fixing screws and sliding the hearth assembly forward and away from the chassis.

In order to service the boiler unit, the fire must be disconnected and removed at this point. Once disconnected the fire unit may be serviced separate from the boiler.

Disconnect the 3-pin plug from the socket beneath the fire.

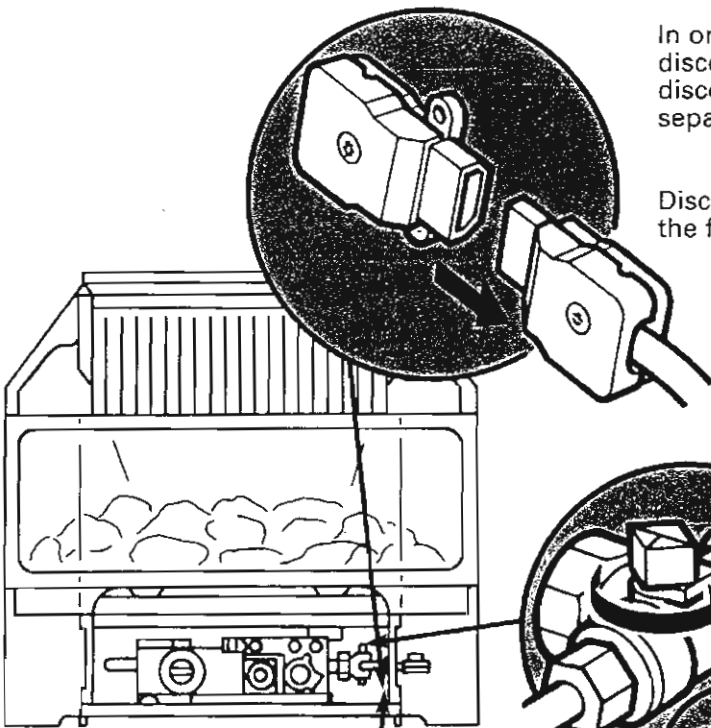

Turn off the gas service cock by turning fully anti-clockwise ( $\frac{1}{4}$  turn).



Disconnect the fire supply pipe from the fire inlet.

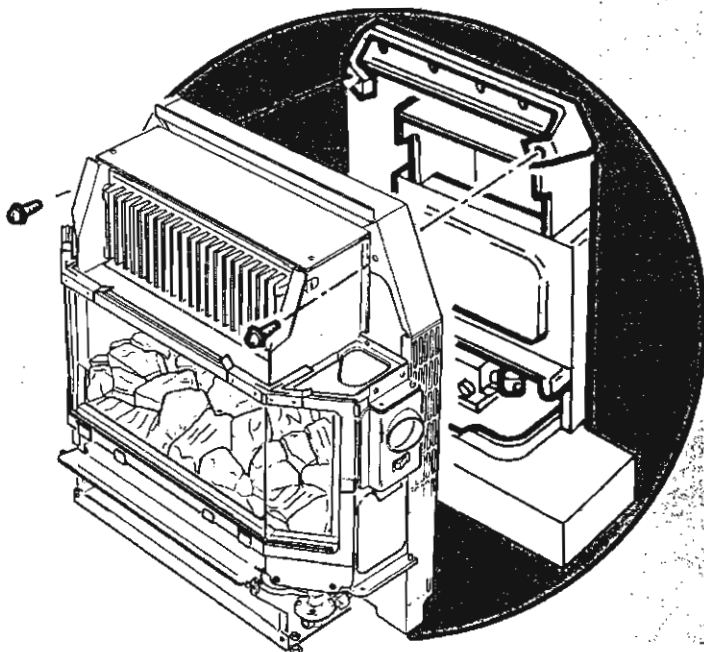
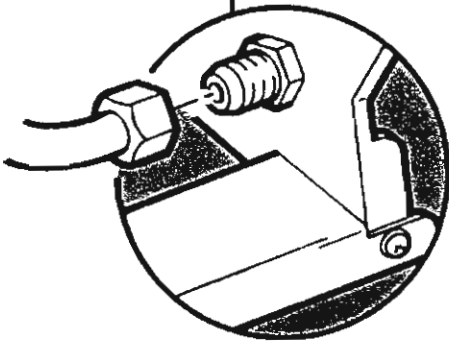

Remove and retain the two screws fixing the chassis to the backing plate. Pull the fire forwards until the flue spigot is clear of the boiler canopy and lift away.

## Cleaning the Electrode Assembly

Ensuring that the glass frame is cold, disengage the retaining clamps and lift the frame away.

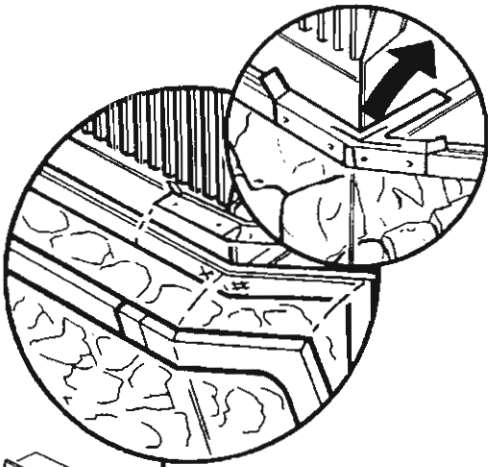

Remove the coal bed by carefully lifting away from the locating pins and place to one side.

**NOTE: The coal bed is extremely fragile and must be handled accordingly.**

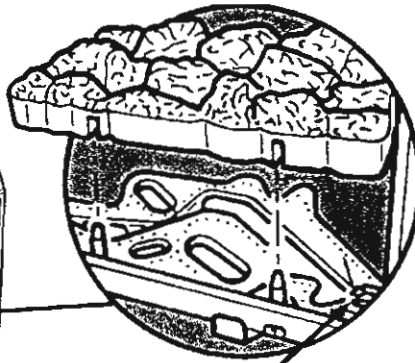

Remove the screw fixing the electrode bracket to the burner.

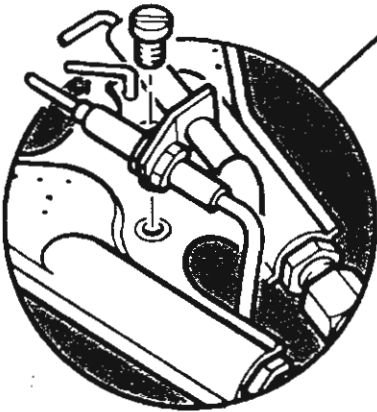

Examine and clean the electrode, target and thermocouple, ensuring that the gap between electrode and target is 3.5 - 4.0mm and that the height of the electrode assembly above the burner is 5.5 - 6.0mm.

At this point, clean the burner and injectors before re-assembling.

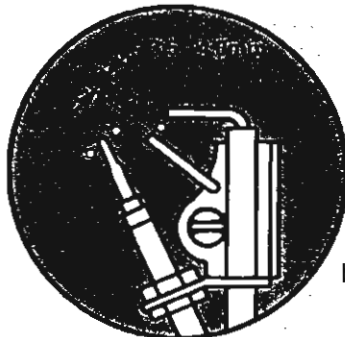

## Cleaning the Burner / Injectors

Remove the burner as follows:

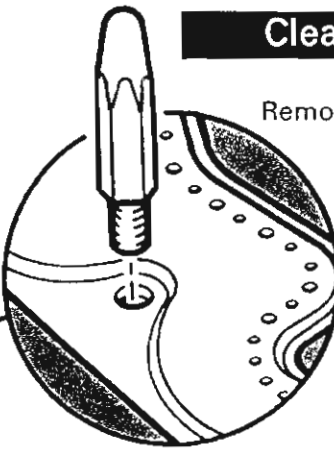

Remove the locating pins (these also secure the burner to its support brackets).

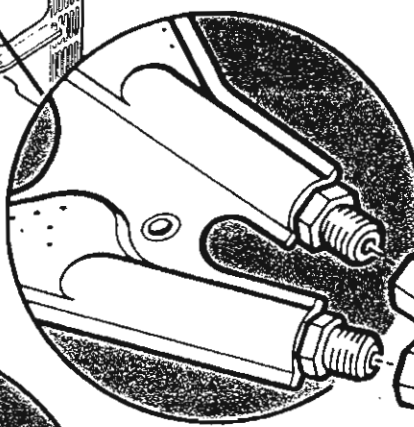

Disconnect the compression nuts from the injectors. Remove the burner from the fire.

Using a soft brush remove any dirt or debris from the top of the burner and ensure that the ports and aeration openings are free from obstruction.

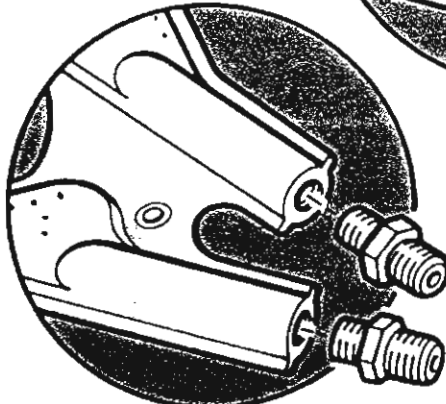

Release and remove the injectors from the burner. Examine and clean carefully then replace.

### BEFORE RE-ASSEMBLING ALL COMPONENTS

Examine the glass frame, if the glass is in any way damaged, then it must be replaced.

**NOTE: This is a heat resistant glass and must not be replaced by "ordinary" glass.**

The glass may be cleaned with a cream cleansing agent if required.

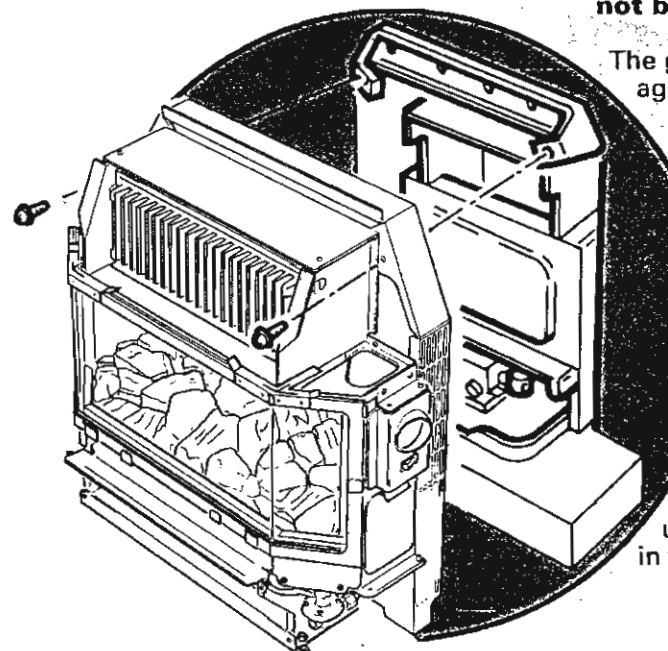

Examine the glass frame sealing rope on the fire and replace it if in any way damaged.

Examine the coal bed and replace it if any major damage has occurred.

Re-assemble all components in reverse order, ensuring that the flue spigot is engaged into the boiler down-draught diverter. Make good all gas and electrical connections and check for gas soundness.

Recommission the fire and boiler before use, then re-assemble the outer components in the reverse order of dismantling.

# CHANGING COMPONENTS

## Bermuda VP

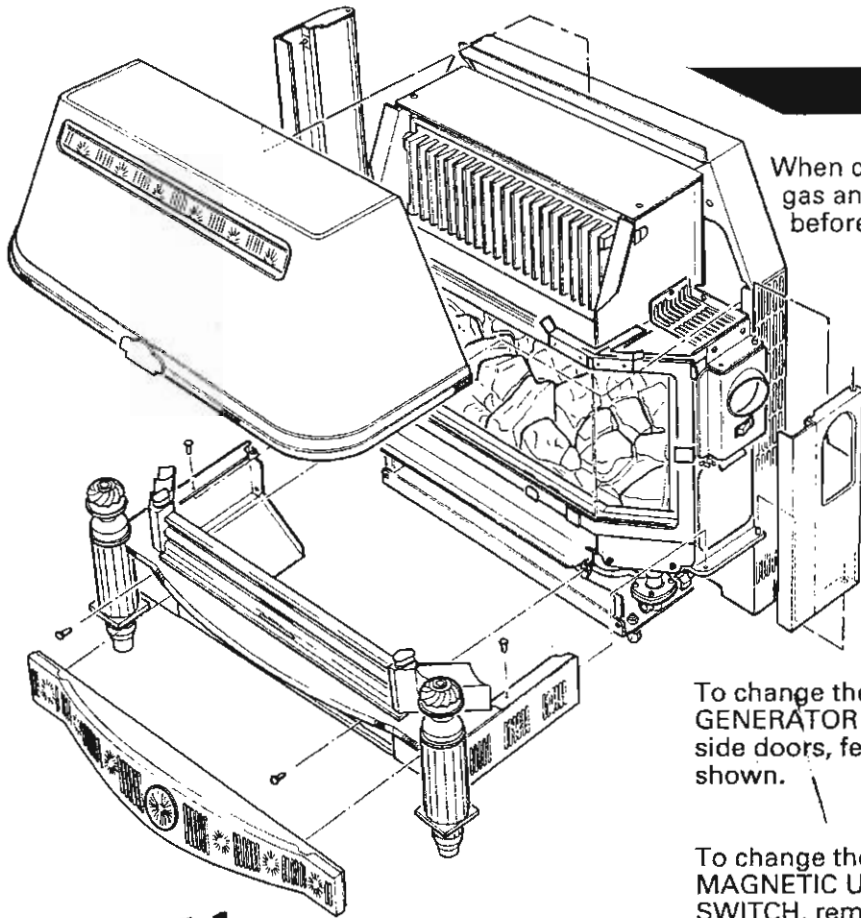

When changing components ensure that the gas and electricity supplies are isolated before the work is started.

To change the GLASS FRAME, FRAME SEALING ROPE, COAL BED, ELECTRODE, BURNER, INJECTORS and LIGHT SWITCH, remove the canopy and side doors as shown.

To change a LIGHT BULB refer to the User's Instructions for this appliance.

To change the ELECTRODE LEAD, SPARK GENERATOR and RESISTOR, remove the canopy, side doors, fender front and hearth assembly as shown.

To change the THERMOCOUPLE, ELECTRO-MAGNETIC UNIT, CONTROL TAP and MICRO-SWITCH, remove the canopy, side door, fender front and hearth assembly. The fire must then be disconnected from the gas supply and removed from the fireplace to give access to the rear of the unit as follows:

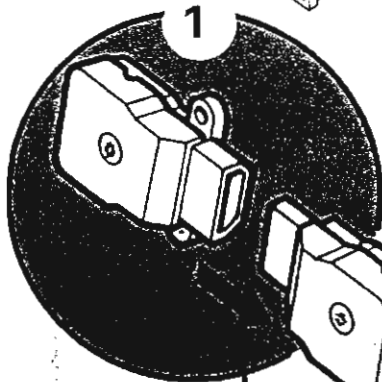

1

1

Disconnect the 3-pin plug from the socket beneath the fire.



2

2

Turn off the gas service cock by turning fully anti-clockwise.

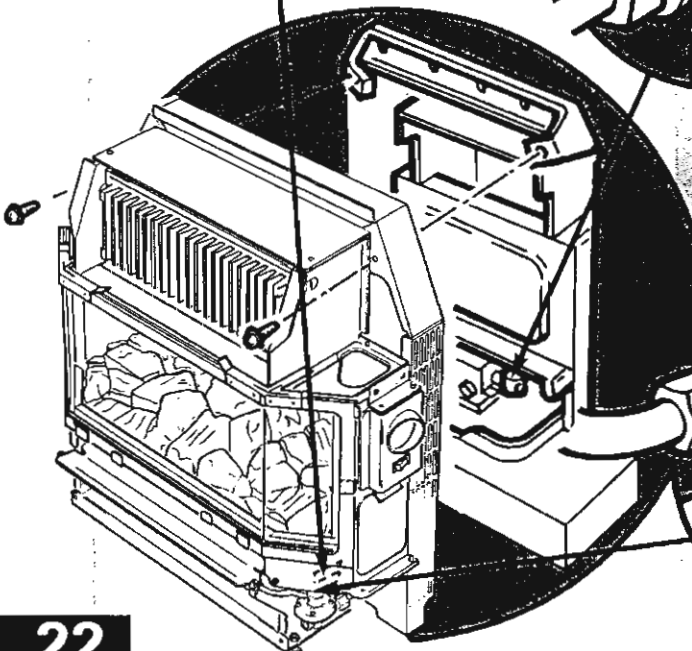

3

Disconnect the fire supply from the fire inlet.

4

Remove and retain the two screws fixing the chassis to the backing plate. Pull the fire forwards until the flue spigot is clear of the boiler canopy and lift away.

3

## Bermuda SP

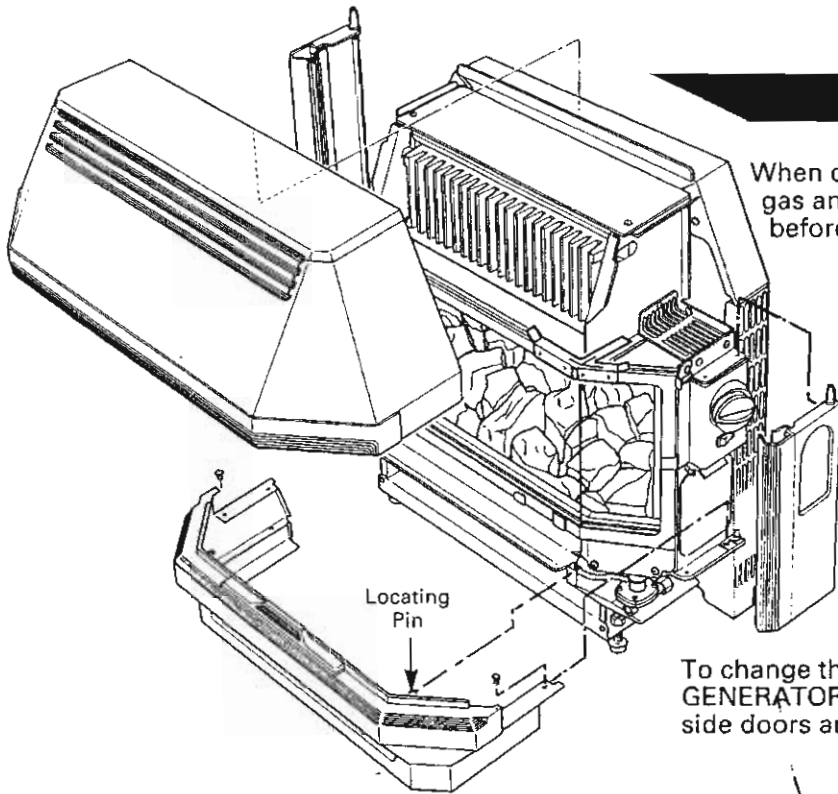

When changing components ensure that the gas and electricity supplies are isolated before the work is started.

To change the GLASS FRAME, FRAME SEALING ROPE, COAL BED, ELECTRODE, BURNER, INJECTORS and LIGHT SWITCH, remove the canopy and side doors as shown.

To change a LIGHT BULB refer to the User's Instructions for this appliance.

To change the ELECTRODE LEAD, SPARK GENERATOR and RESISTOR, remove the canopy, side doors and hearth as shown.

To change the THERMOCOUPLE, ELECTRO-MAGNETIC UNIT, CONTROL TAP and MICRO-SWITCH, remove the canopy, side door and hearth. The fire must then be disconnected from the gas supply and removed from the fireplace to give access to the rear of the unit as follows:

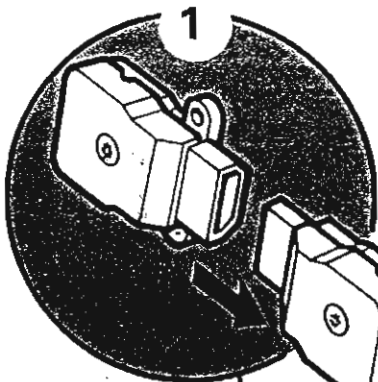

1  
Disconnect the 3-pin plug from the socket beneath the fire.

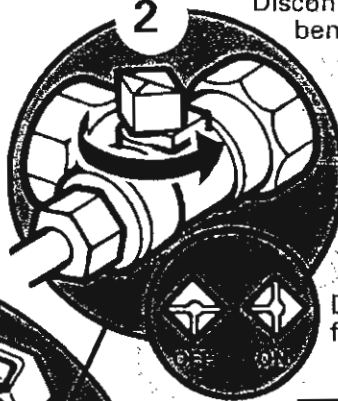

2  
Turn off the gas service cock by turning fully anti-clockwise.



3  
Disconnect the fire supply from the fire inlet.

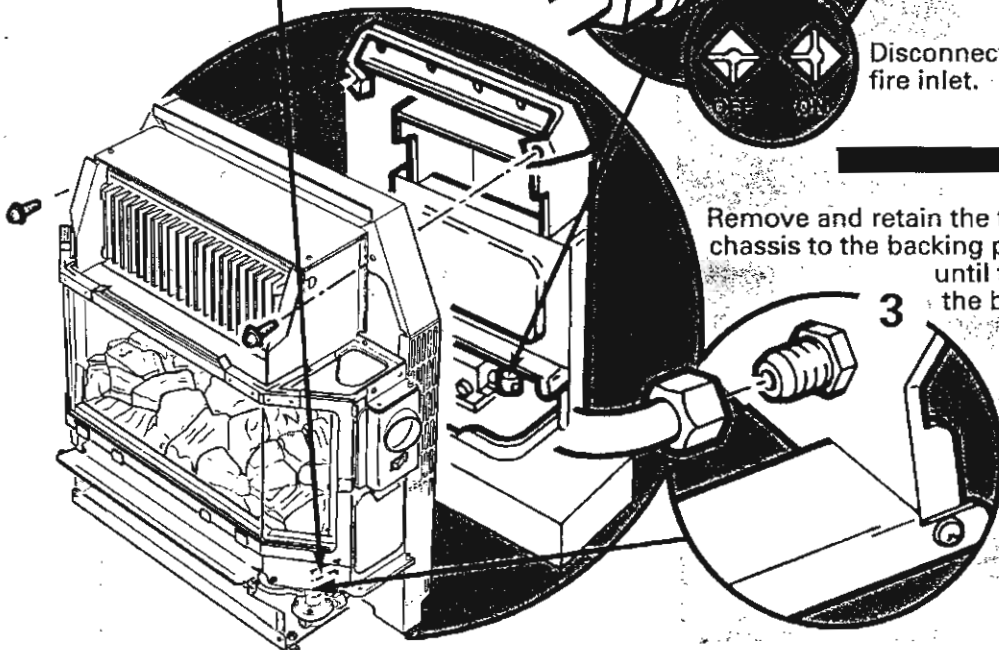

4  
Remove and retain the two screws fixing the chassis to the backing plate. Pull the fire forwards until the flue spigot is clear of the boiler canopy and lift away.

## Glass Frame

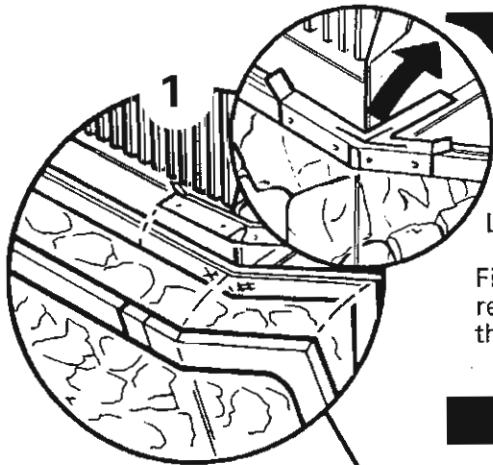

1  
Ensure that the glass panel is cold. Disengage the retaining clamps.

Lift the frame away.

Fix the new glass frame in position and engage the retaining clamps. Re-assemble the components in the reverse order to dismantling.

## Frame Sealing Rope

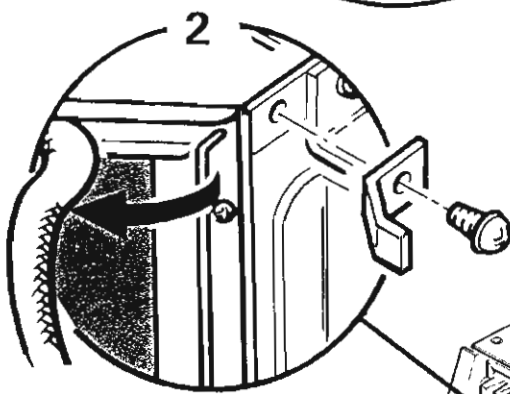

1  
Ensure that the glass panel is cold. Disengage the retaining clamps.

Lift the frame away.

2  
Pull the old rope seal out of the locating channel and release the glass locating brackets.

Fit the new seal, starting at the centre, tuck well into the locating channel. Ensure that there is an equal amount of seal free at either end of the channel. Secure the glass locating brackets.

Fix the glass frame in position and engage the retaining clamps. Re-assemble the components in the reverse order to dismantling.

Check that the seal between the rope and the glass frame is good.

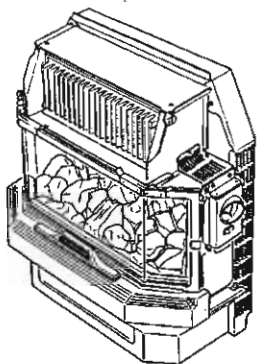

Bermuda SP showing Hearth in position

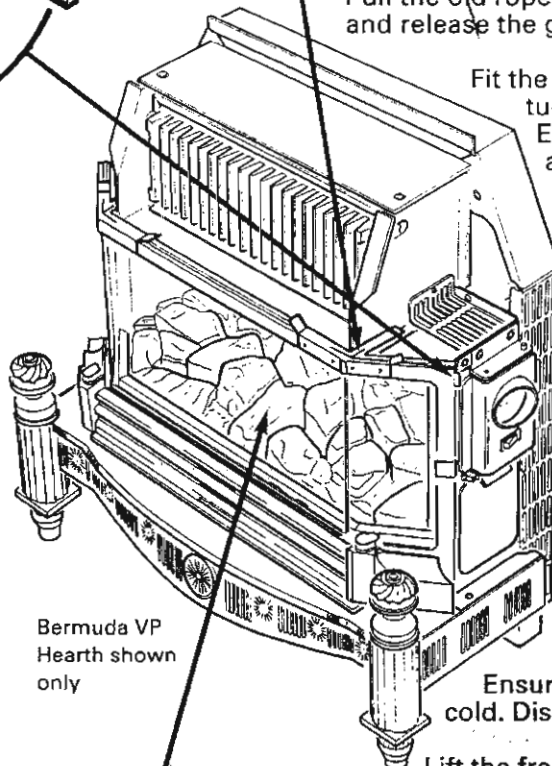

Bermuda VP Hearth shown only

## Coal Bed

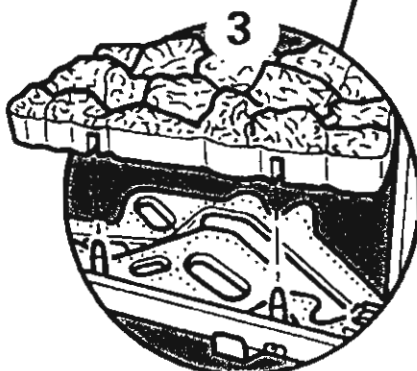

1  
Ensure that the glass panel is cold. Disengage the retaining clamps.

Lift the frame away.

3  
Lift the coal bed away from the locating pins.

Carefully fit the new coal bed in position on the locating pins. Fix the glass frame in position and engage the retaining clamps. Re-assemble the components in the reverse order to dismantling.



## Electrode

1

Ensure that the glass panel is cold. Disengage the retaining clamps and lift the frame away.

2

Lift the coal bed away from the locating pins and place to one side.

**NOTE: The coal bed is extremely fragile and must be handled accordingly.**

3

Remove the screw securing the electrode bracket to the burner.

4

Carefully release the locknut fixing the thermocouple to the electrode bracket. Remove the two insulating sleeves from the electrode body to reveal the electrode connection. Disconnect the electrode lead from the electrode.

Reconnect electrode lead and thermocouple to new electrode.

Fix new electrode to burner using the screw previously removed. Fit the two insulating sleeves over the body of the electrode.

Bermuda VP  
Hearth shown  
only

Ensure that the spark gap between electrode and target is 3.5 - 4.0mm and that the height of the electrode assembly above the burner is 5.5 - 6.0mm.

Fit the coal bed in position. Fix the glass frame in position and engage the retaining clamps. Re-assemble the components in the reverse order to dismantling.

## Burner and Injectors

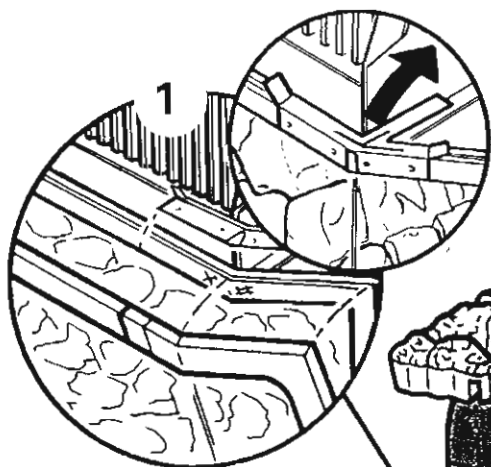

1

Ensure that the glass panel is cold. Disengage the retaining clamps and lift the frame away.

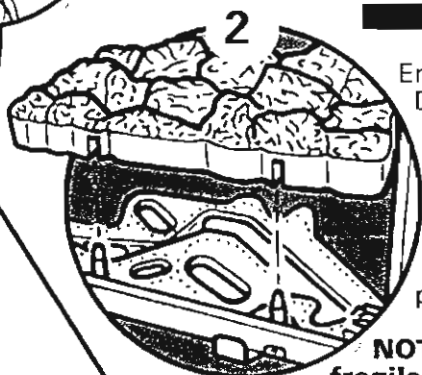

2

Lift the coal bed away from the locating pins and place to one side.

**NOTE: The coal bed is extremely fragile and must be handled accordingly.**

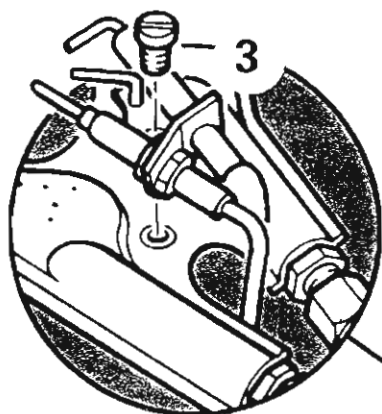

3

Remove the screw securing the electrode bracket to the burner.

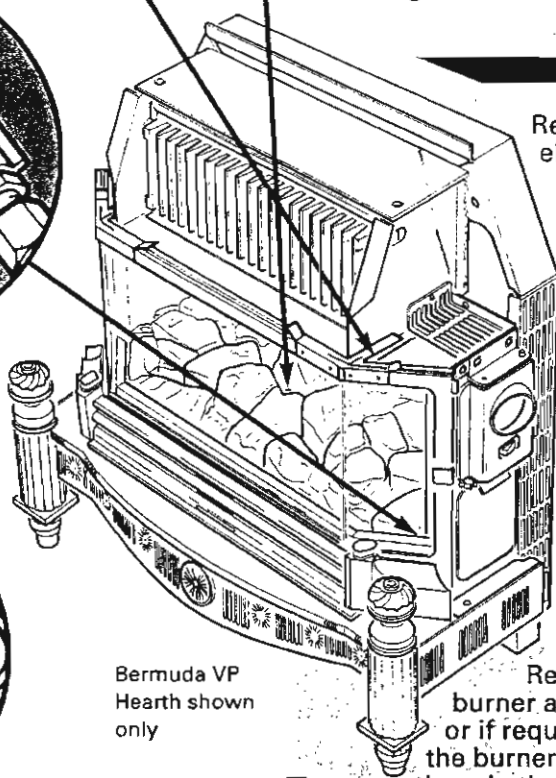

4

Remove the locating pins securing the burner to its support brackets.

5

Disconnect the compression nuts from the injectors.

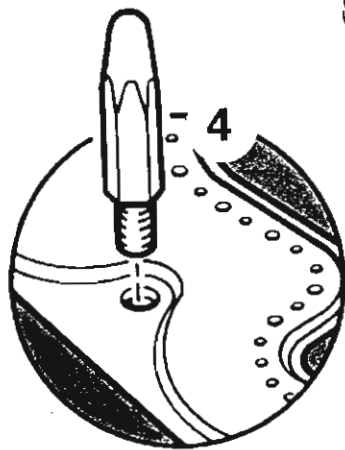

6

Remove the injectors from the old burner and fit them into the new burner or if required fit new injectors (flat end in the burner) taking care not to over tighten them in their mountings.

Bermuda VP  
Hearth shown  
only

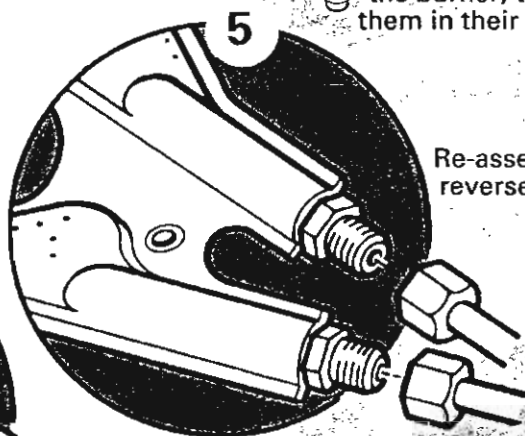

Re-assemble the components in the reverse order to dismantling.

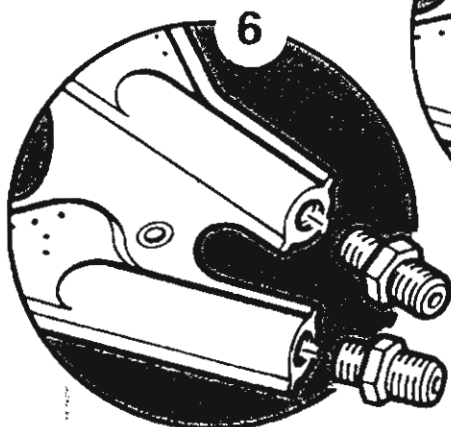

## Light Switch

**Ensure that the electricity supply to the fire unit is isolated.**

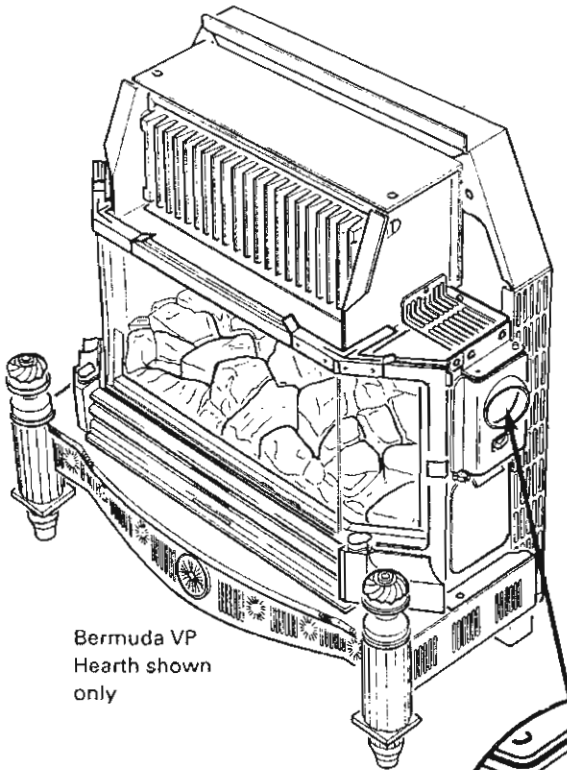

Bermuda VP  
Hearth shown  
only

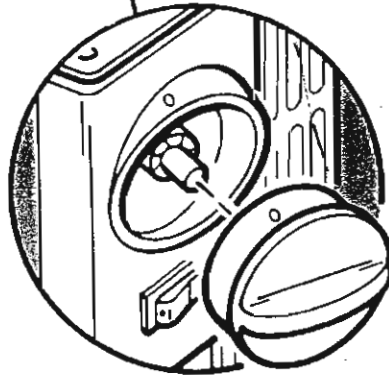

Remove the control knob by pulling from the spindle.

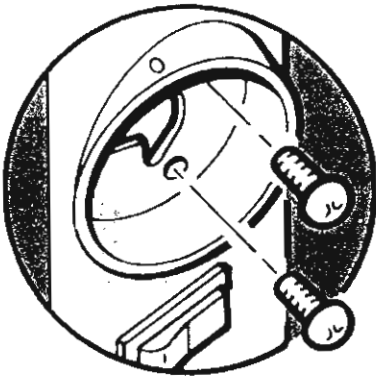

Remove the two screws holding the bezel in place.

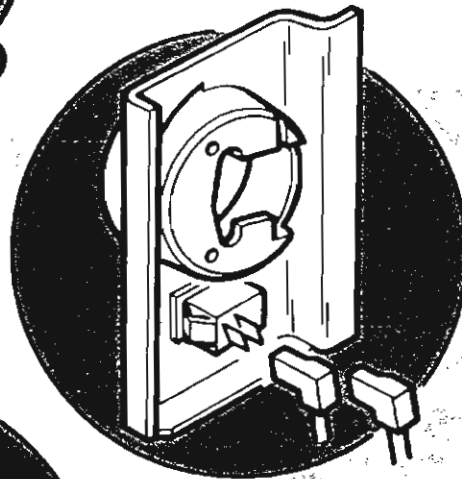

Note the orientation of the two electrical connections and disconnect from the switch. Remove the bezel.

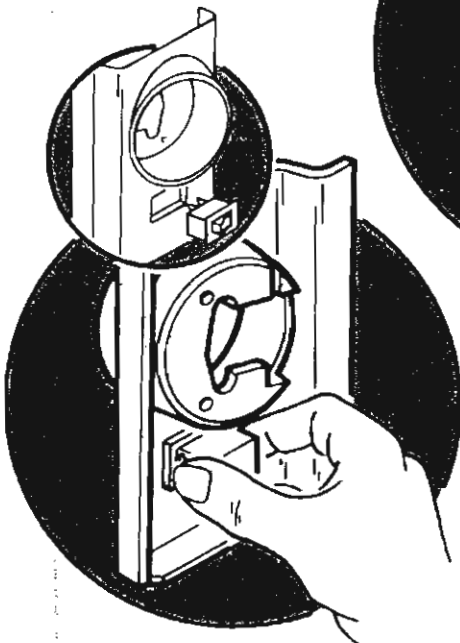

Press together the retaining arms on the rear of the switch and remove from the bezel.

Fit the new switch in place, ensure that the orientation of the switch is correct. (i.e. with the 'O' symbol towards the front of the fire.) and make good the electrical connections.

Re-assemble the components in the reverse order to dismantling.

## Electrode Lead

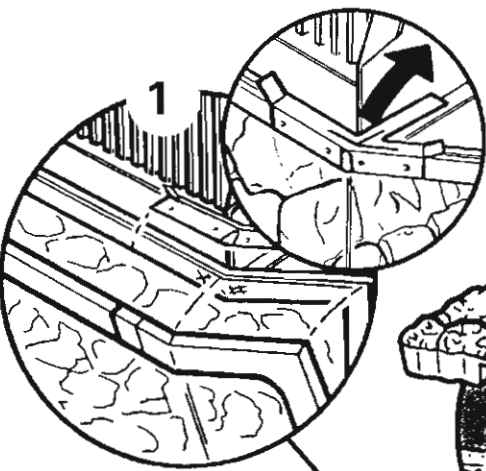

1  
Ensure that the glass panel is cold.  
Disengage the retaining clamps and lift  
the frame away.

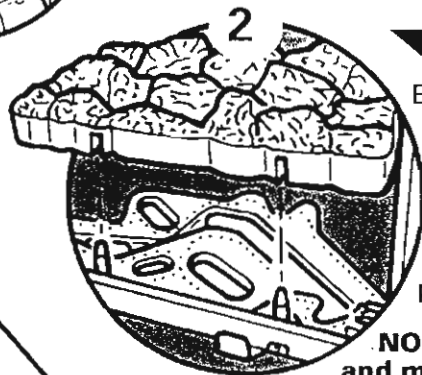

2  
Lift the coal bed away from the locating  
pins and place to one side.

**NOTE: The coal bed is extremely fragile  
and must be handled accordingly.**

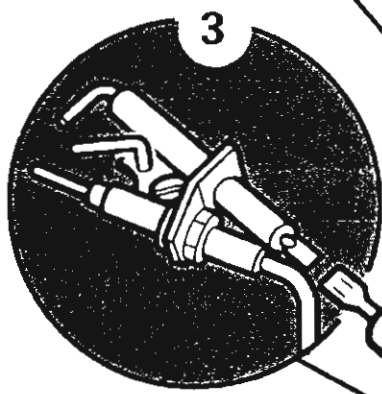

3  
Remove the two insulating sleeves  
from the body of the electrode.  
Disconnect the electrode lead  
from the electrode.

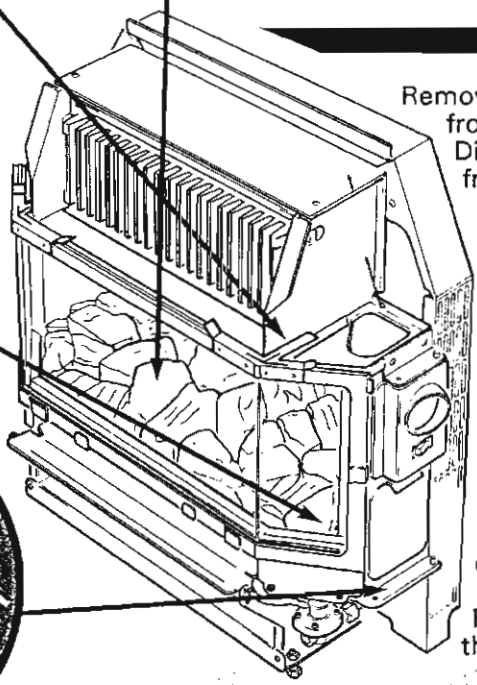

4  
Disconnect the electrode lead  
from the spark generator.

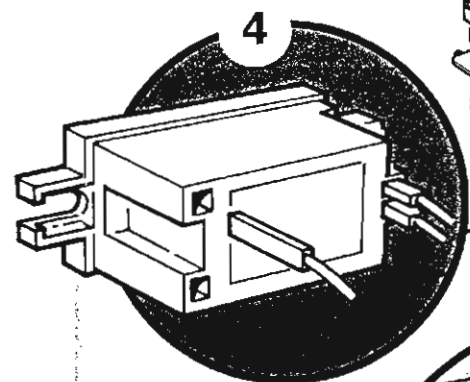

Thread the new electrode lead  
through the insulating sleeves.  
Fit the new electrode lead to the  
spark generator and electrode.  
Refit the two insulating sleeves  
over the body of the electrode.

Re-assemble the components in  
the reverse order to dismantling.

## Spark Generator

Remove the front screw holding  
the spark generator in place, and  
release the rear screw, enabling  
the generator to be removed.  
Disconnect the electrical  
connections and electrode lead.

Fit the new spark generator and  
re-assemble all components in the  
reverse order to dismantling.

## Resistor

Remove the two screws securing the light shield  
bracket. Unclip the resistor from the side frame.  
Disconnect the two resistor wires from terminal  
strip. Replace resistor and refit in reverse order.

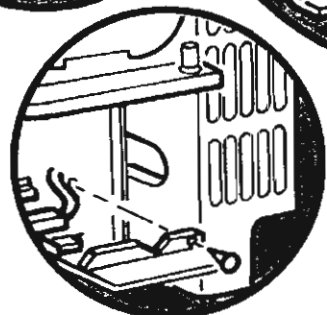

## Thermocouple

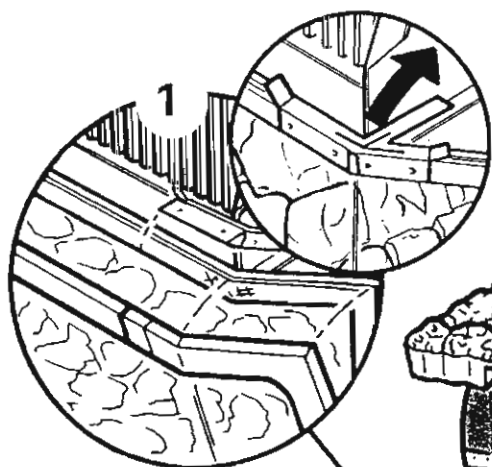

1

Ensure that the glass panel is cold. Disengage the retaining clamps and lift the glass frame away.

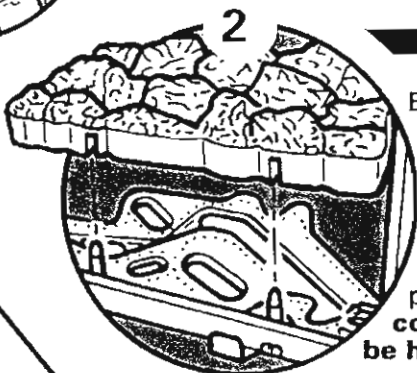

2

Lift the coal bed away from the locating pins and place to one side. **NOTE: The coal bed is extremely fragile and must be handled accordingly.**

3

Release the locknut fixing the thermocouple to the electrode bracket.

4

Release the thermocouple from the control tap by unscrewing the retaining nut and remove.

Shape the new thermocouple to match the old one and fix in place, taking care not to overtighten the retaining nut.

Re-assemble all components in the reverse order to dismantling.

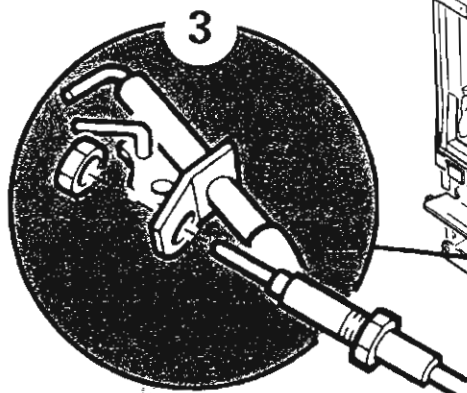

3

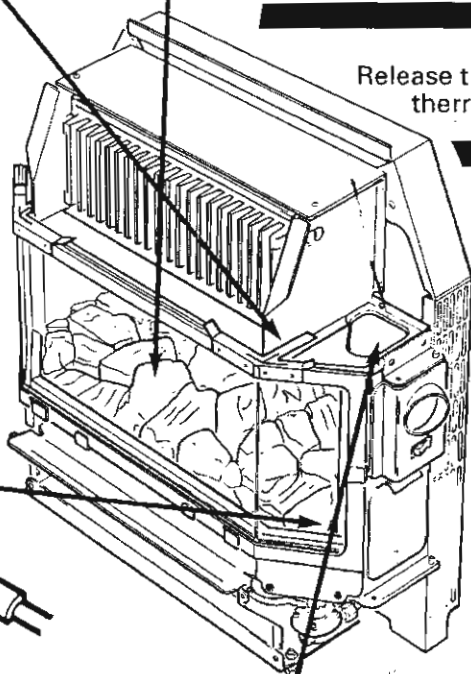

4

## Electro-Magnetic Unit

4

Release the thermocouple from the control tap by unscrewing the retaining nut.

5

Release the Electro-Magnetic Unit retaining nut and remove the unit from the control tap. Fit the new Electro-Magnetic Unit and replace the retaining nut.

Fix the thermocouple in position taking care not to overtighten the retaining nut. Re-assemble all components in reverse order to dismantling.

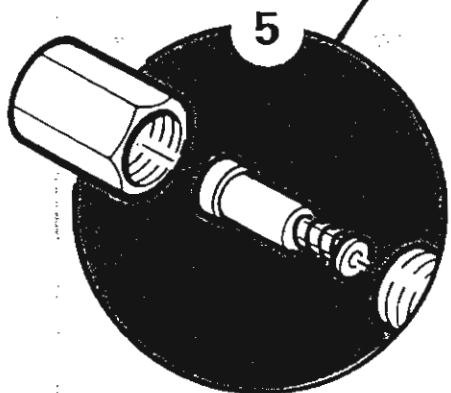

5

## Control Tap and Micro-Switch

Remove the control knob by pulling from the spindle.

Remove the two screws holding the bezel in place.

Disconnect the two electrical connections from the light switch, taking note of their orientation. Remove the bezel.

Release the thermocouple from the control tap by unscrewing the retaining nut.

Disconnect the two electrical connections from the micro switch.

Release the nut-and-olive connections on the control tap body and disconnect the bundy tubing from the control tap.

Disconnect the gas inlet at the control tap by releasing the compression fitting.

Release the locknut fixing the control tap to the chassis. Access to the locknut may be gained through the bezel location.

Withdraw the control tap from the fire.

At this point change the micro-switch if required by removing the circlip holding it in position on the control tap.

Fit the new micro-switch or the new control tap in reverse order.

Make good all gas and electrical connections. Temporarily reconnect electricity supply. Light the fire, turn off the electricity supply and check all joints for gas soundness. Turn the fire off. Re-assemble all components in reverse order to dismantling.

# SHORT PARTS LIST

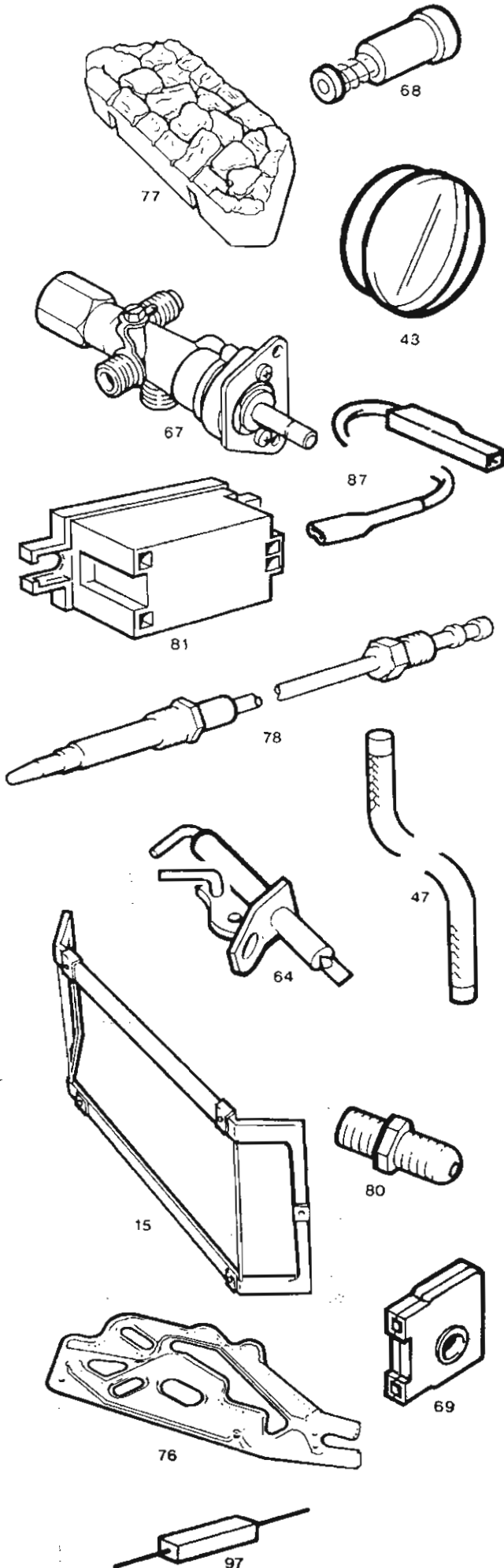

Key No.	G.C. No.	Description	Manufacturers Part No.
15	156 036	Glass and Frame Assy	225391
43	156 060	Knob Control	227306
47	156 063	Seal Frame Glass Rope	226876
64	155 952	Electrode	092137
67	386 811	Gas Tap	225765
68	384 248	Electro Magnetic Unit	082462
69	156 095	Micro Switch Assy	227761
76	156 094	Burner	225400
77	156 075	Coal Bed	226877
78	378 545	Thermocouple	230677
80	397 681	Injector Burner (2 off)	227348
81	379 671	Spark Generator	233254
87	156 231	Electrode Lead (2.8mm)	232788
97	386 129	Resistor 68 $\Omega$	228955

The following components are unique to the PROPANE appliance only:

Key No.	Description	Manufacturers Part No.
67	Gas Tap	228170
76	Burner	228484
77	Coal Bed	228485
80	Injector Burner	228486

# FAULT FINDING

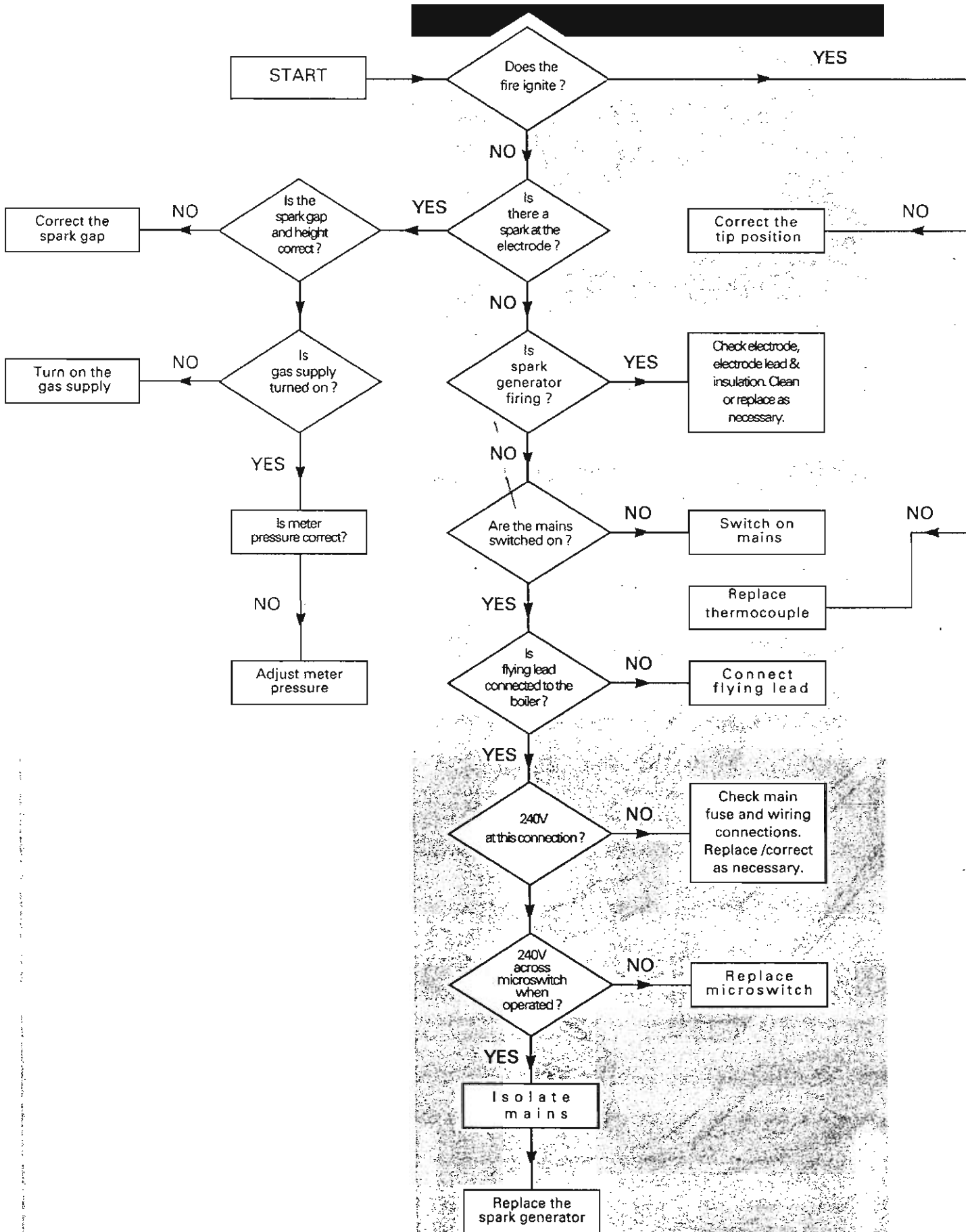



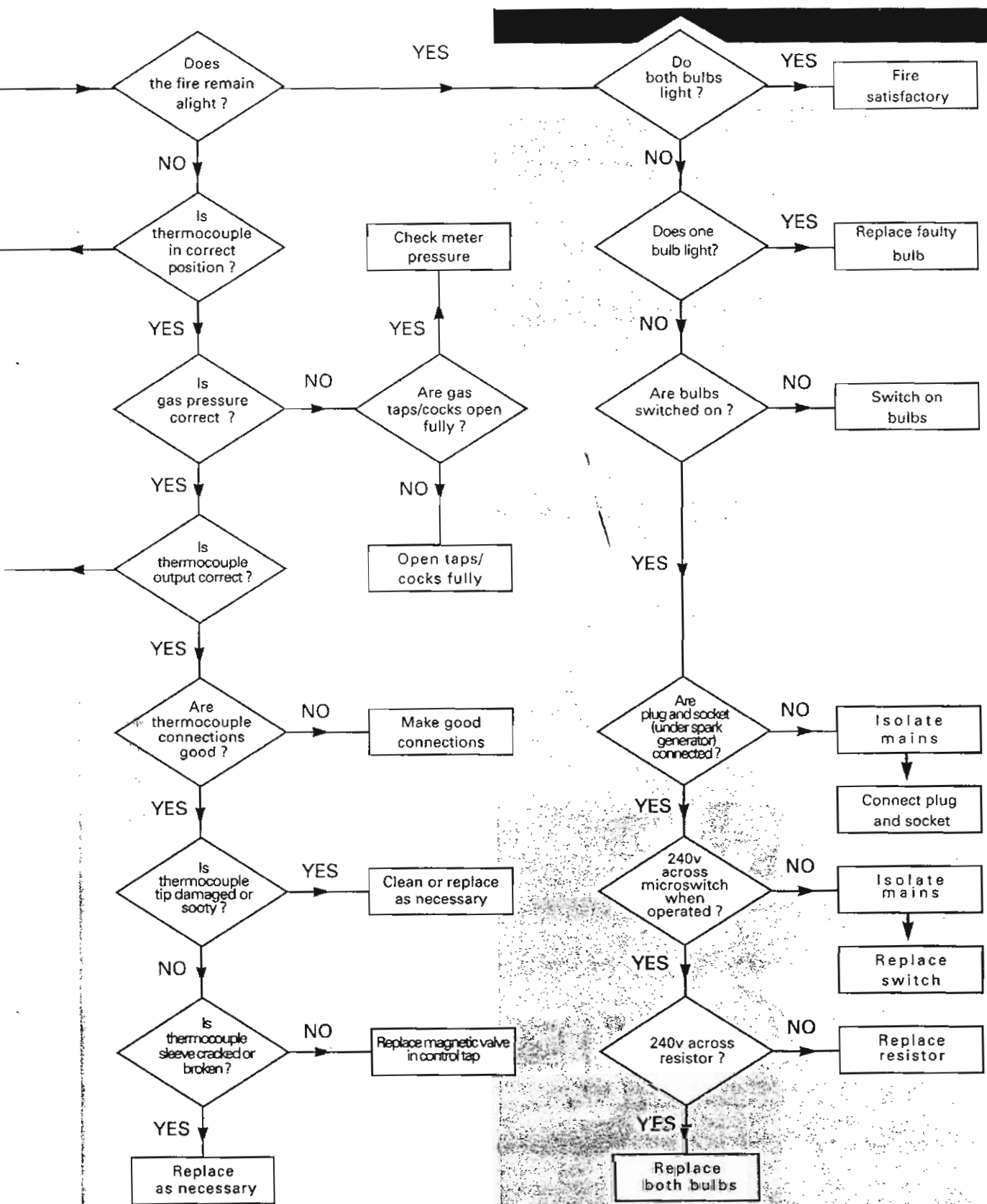

# PROPANE Cat 13P

## Supplementary Instructions

### BERMUDA VP and SP PROPANE

<b>Heat Input</b>	High	Med-High
kW	5.86	4.98
Btu/h	20,000	17,000
<b>Heat Input</b>	Med	Low
kW	3.13	1.99
Btu/h	10,700	6,800
<b>Heat Output</b>	High	
kW	3.60	
Btu/h	12,300	
<b>Supply Pressure</b>		
mbar	37	
in wg	14.8	
<b>Setting Pressure</b>	Cold	
mbar	34.2 ± 1.5	
in wg	13.7 ± 0.6	

These supplementary instructions should be read in conjunction with the Fire Installation and Servicing Instructions and cover certain features unique to the Propane appliance.

The Heat Input, Heat Output and Setting Pressures given in the Instructions Booklet do not apply to the Propane appliance. Refer to the table opposite.

## Burner Removal

(See page 26 and substitute instruction 4 with the paragraph below.)

The left hand locating pin does not secure the burner to the support bracket. To remove the burner, unscrew the right hand locating pin and the set screw at the left hand side.

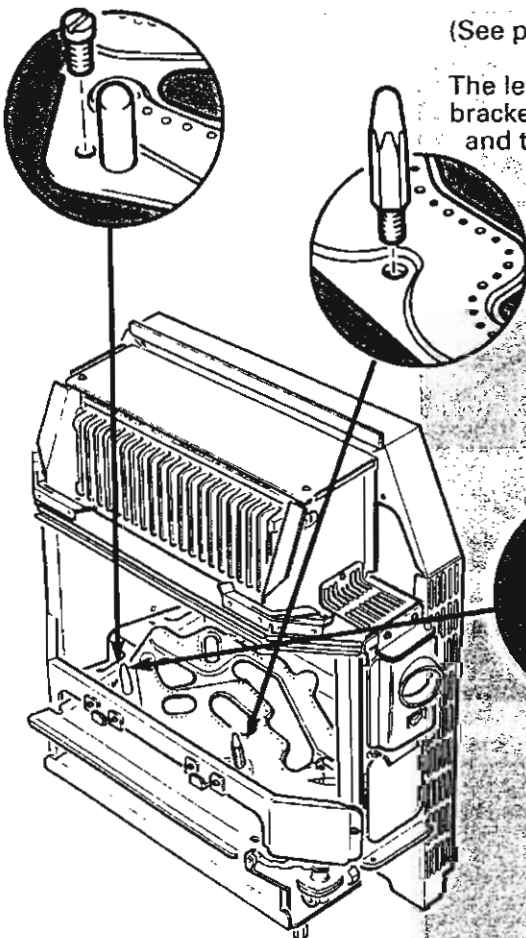

## Burner Replacement

When replacing the burner remove the left hand locating pin from the old burner and refit to the new burner.

(See page 26 for re-assembling all components in the reverse order to dismantling.)

# RENEWAL FIREFRONT

## Supplementary Kit Instructions

### BERMUDA 675/551/401/552 ADDITIONAL INSTALLATION INSTRUCTIONS

This kit contains:

- 1 - Additional installation instructions
- 1 - Adhesive label (users operating)
- 1 - Adhesive label (British Gas tested and certificated)
- 1 - Adhesive label (data)
- 1 - Plug button
- 1 - Plug button special
- 1 - Anti-spread cup and washer
- 2 - Flue blanking plates
- 2 - Self tapping screws
- 1 - Boiler baffle (packed separately)
- 1 - Foil label (internal wiring)

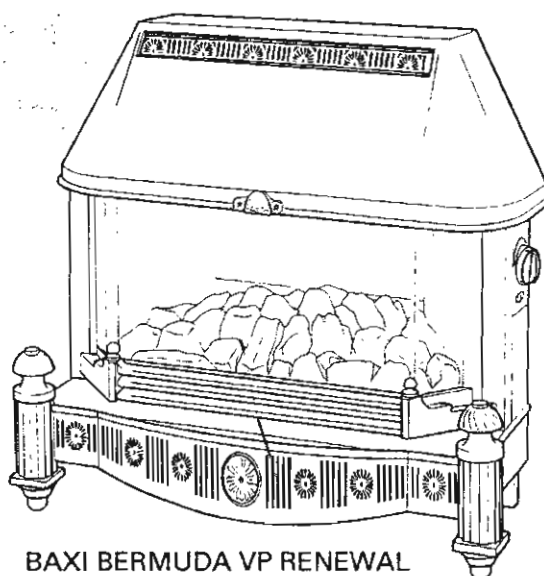

BAXI BERMUDA VP RENEWAL  
G.C.N° 156 099

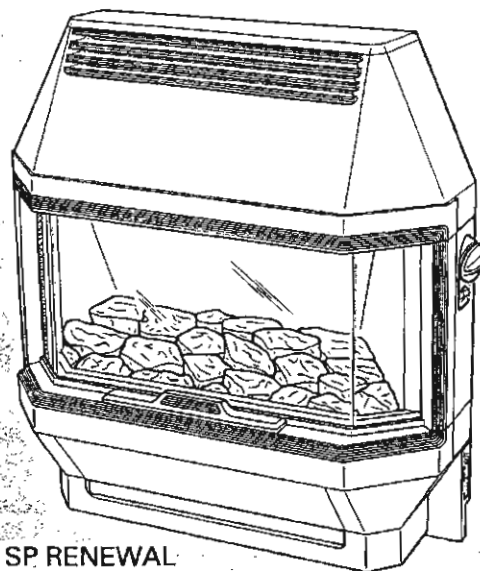

BAXI BERMUDA SP RENEWAL  
G.C.N° 156 099

These Instructions must be read in conjunction with the Installation and Servicing Instructions in the front of this booklet.

The fire may be used with the following boilers:

- Bermuda 675 - G.C.N° (common to existing fire)
- Bermuda 551 - G.C.N° 44 077 48
- Bermuda 401 - G.C.N° 44 077 49
- Bermuda 552 - G.C.N° 44 077 50

It is important that the existing installation is correct and that the flue is performing satisfactorily. Any remedial work necessary should be completed before the new appliance is commissioned.

This kit provides all the necessary components to fit a Bermuda VP or SP Renewal firefront to the Bermuda 675/551/401/552 central heating boiler range.

For removal of the existing fire and adaptation of the back boiler see the relevant section.

## Existing Fire

### REMOVING THE EXISTING FIRE

Switch off the electrical supply to the combined appliance.

Remove the controls cover panel from the front of the fire.

Remove the tap control knob. Disconnect the electrical socket from the fire plug if fitted. Remove the screws securing the outercase to the innercase. Lift off the outercase.

Turn the gas service tap to the "Boiler only" position by turning  $\frac{1}{4}$  turn clockwise.

Remove the radiants if fitted.

Disconnect the supply pipe at the fire inlet.

Remove any screws securing the fire to the wall. Pull the fire forward until the flue spigot is clear of the boiler hood and lift away.

Remove and discard the fire supply pipe from the service gas tap. Disconnect and discard any electrical wiring between the boiler input terminal and the fire.

If the fire is wall mounted remove and discard the existing support frame but retain the two support brackets if fitted. These will be needed in wall mounting the renewal fire.

If the fire is hearth mounted ensure that the base of the builders opening and the front hearth are at the same level

## Boiler Adaptation

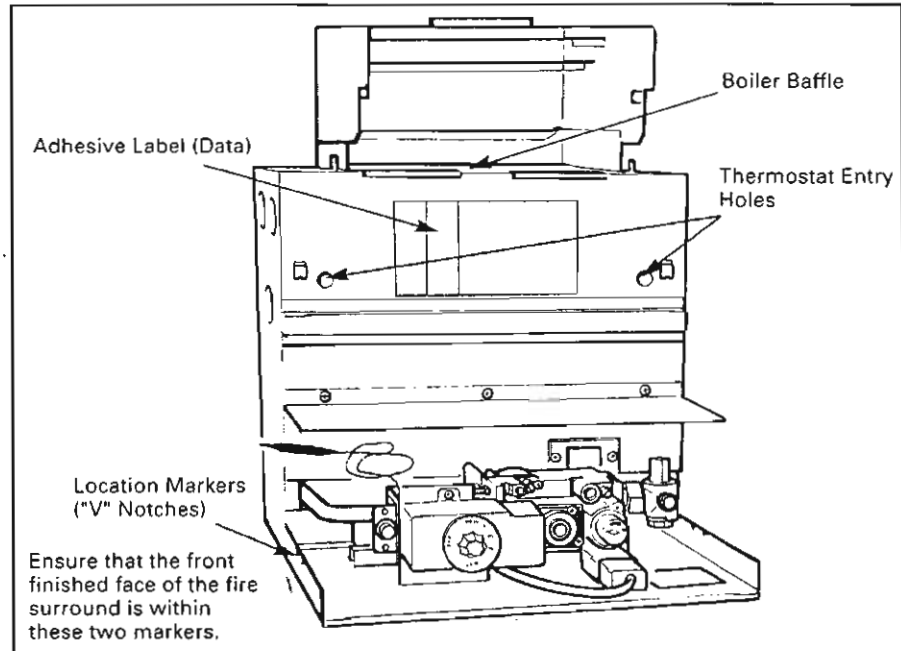

When fitting the VP or SP Renewal fire to a Bermuda 551 with a boiler burner with slots for the gas ports instead of round holes (see sketch) carry out the following instructions:

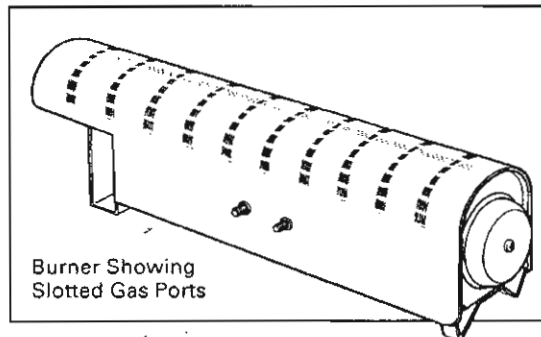

Check that the maximum burner pressure does not exceed 15mbar (6in wg.). This gives a heat input of 19.3 kW (65,850 Btu/h). Output 14.09 kW (48,070 Btu/h).

Fit the self adhesive label over the maximum setting information on the boiler data badge.

**IF THE REQUIRED INPUT IS GREATER THAN 19.3 kW (65,850 Btu/h) A NEW BURNER MUST BE FITTED. BAXI CODE N° 042 768 G.C.N° 183 620.**

Fit the new burner as follows:

- Turn the gas service tap off by turning  $\frac{1}{2}$  turn anti-clockwise. Disconnect at the union.

- Remove the thermostat phial from its pocket; remove the wing nuts securing the boiler door and remove the door.

- Remove the screw on the electrical plug. Remove the plug from the socket.

- Remove the two screws retaining the controls to the boiler base. Remove the controls from the boiler.

- Remove the nuts securing the pilot bracket and the burner mounting bracket.

- Remove the burner feed pipe by disconnecting at the nut and olive on the burner.

- Remove the burner from the controls and remove the lint arresters.

- Remove the nut and angled baffle from the burner. Unscrew the injector.

- Fit the new burner in reverse order of dismantling.

- Refit the boiler door and thermostat phial.

- Use the 2 plug buttons provided to blank off the two round thermostat entry holes in the boiler door. Use the button with the raised edge on it to blank off the side where the thermostat phial is fitted.

**NOTE:** Do not fit the adhesive label (data) to the boiler data badge.

- When fitting the VP or SP to a Bermuda 675; replace the existing boiler baffle with the new one provided after first removing the boiler door.

For fire preparation and installation read these supplementary instructions in conjunction with the Installation Instructions at the beginning of this booklet.

## Installation

### SITE REQUIREMENT

The surround or wall finish must be of non combustible material and have a flat area measuring a minimum of 765mm (30<sup>1</sup>/<sub>8</sub> in) high by 765mm (30<sup>1</sup>/<sub>8</sub> in) wide. The fireplace opening should be:

Height - 560mm (22in) Width - 406mm (16in) min  
508mm (20in) max

### INITIAL PREPARATION

Unpack the fire and accessories.

When fitting to a Bermuda 675/551, fasten the two flue blanking plates to the underside of the flue outlet with the screws provided (fig 1).

fig 1 Flue Outlet

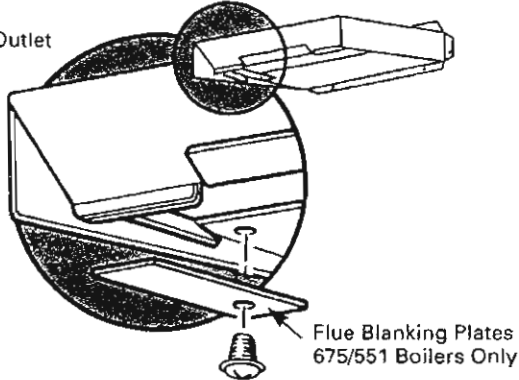

Use the label British Gas Tested and Certificated to blank off the British Standards Safety Mark on the fire data badge when fitting to a Bermuda 675/551.

When fitting to a Bermuda 675 the User's Operating Instructions Label situated on the fire controls cover plate must be replaced by the label marked Baxi Bermuda VP/SP.

### ELECTRICAL CONNECTIONS

For Bermuda 552/401 refer to page 7 in the Fire Section Installation Instructions.

For Bermuda 675/551 follow the procedure below:

**NOTE: A permanent live must be fitted on the input socket marked '2' (marked '3' on Bermuda 675).** The 4 core input cable for connection to the boiler unit must not be less than 0.75mm<sup>2</sup> (24 x 0.2mm) PVC heat resistant to 70°C Grade 1 to BS 6500 table 15 or 16. It is important to route any input cable to avoid contact with the combustion box sides.

The method of connection to the electricity supply must facilitate complete electrical isolation of the appliance. Connection may be made via a fused double pole isolator with a contact separation of at least 3mm (1/8 in) in all poles and serving the appliance and systems control only (max. fuse rating 3 amp).

All external wiring must be in accordance with current I.E.E. Wiring Regulations.

The electrical supply to the fire is via a length of 3 core cable and a 3 pin plug. The cable must be connected to the electrical input terminal on the boiler base. These connections must be made as follows:

Remove the boiler earth wire from the earth terminal marked 'E' on the right hand side of the input terminal. Gain access to the electrical input terminals.

Connect the blue wire to the terminal marked 'N'.

Connect the brown wire to the terminal marked '2' (marked '3' on Bermuda 675).

Connect the green/ yellow wire to the earth terminal marked 'E'.

Replace the boiler earth using the anti-spread cup and washer supplied with this kit. Tighten the earth securing nut.

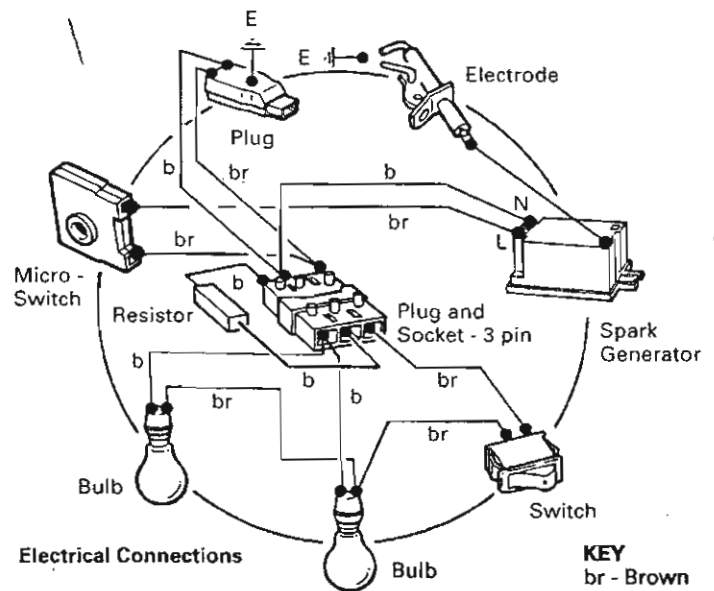

Electrical Connections

**KEY**  
br - Brown  
b - Blue

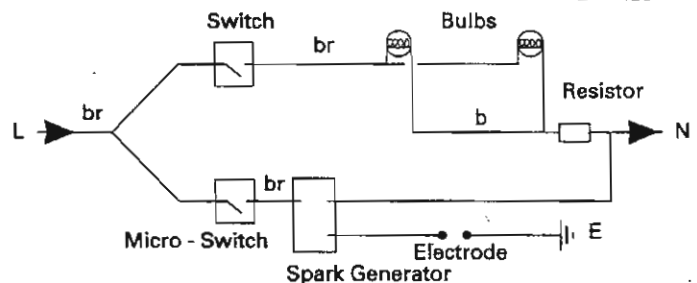

Functional Flow Diagram

To continue with the installation we can now revert to the Bermuda VP/SP Installation and Servicing Instructions Booklet starting at the Gas Supply section (page 10).

**IMPORTANT.** When the controls heat shield is replaced by the one supplied with the convector the 'FOIL LABEL' showing the Internal Wiring **MUST** be affixed to the top side of it.

# BERMUDA BOILER FAULT FINDING CHART

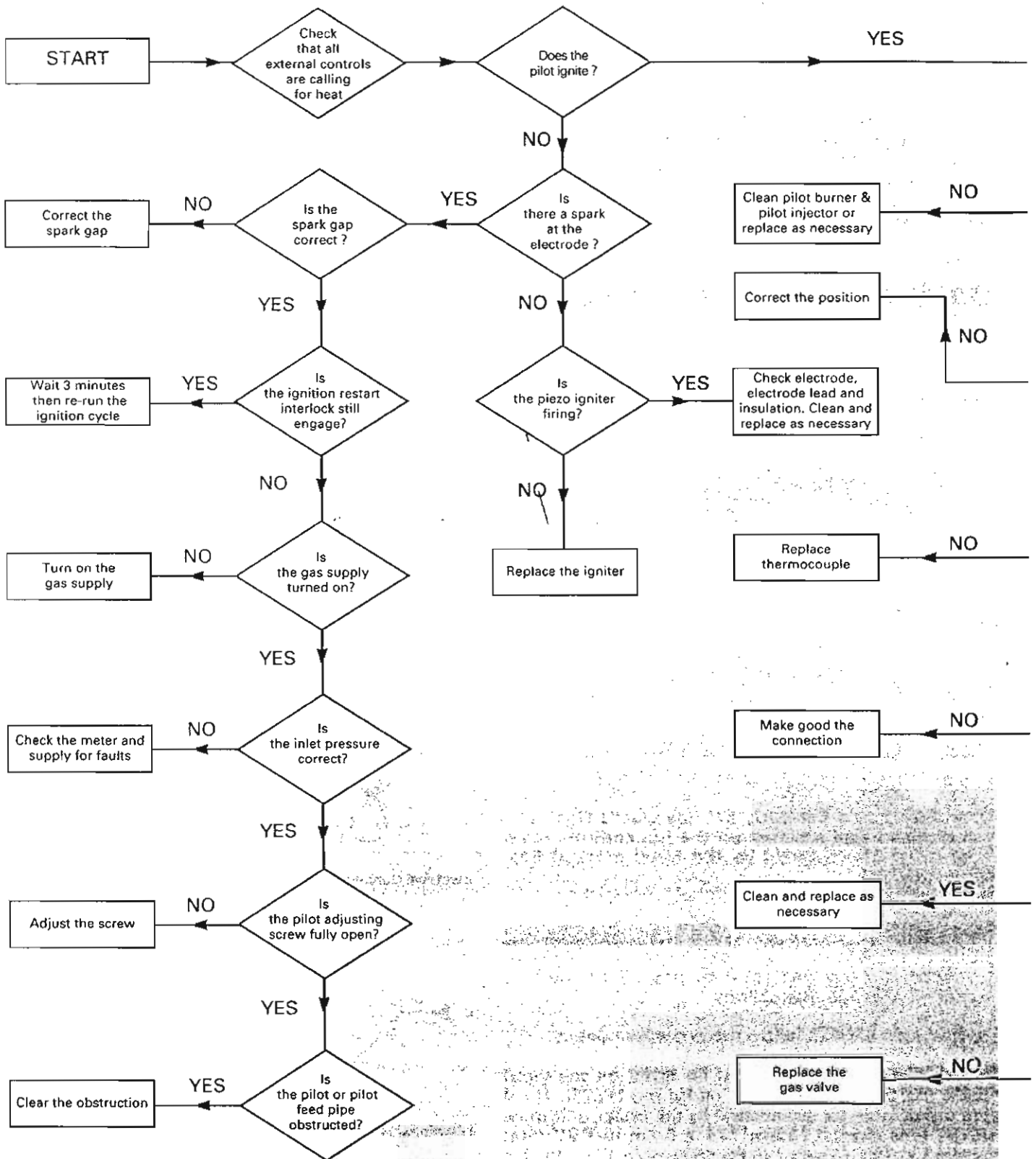

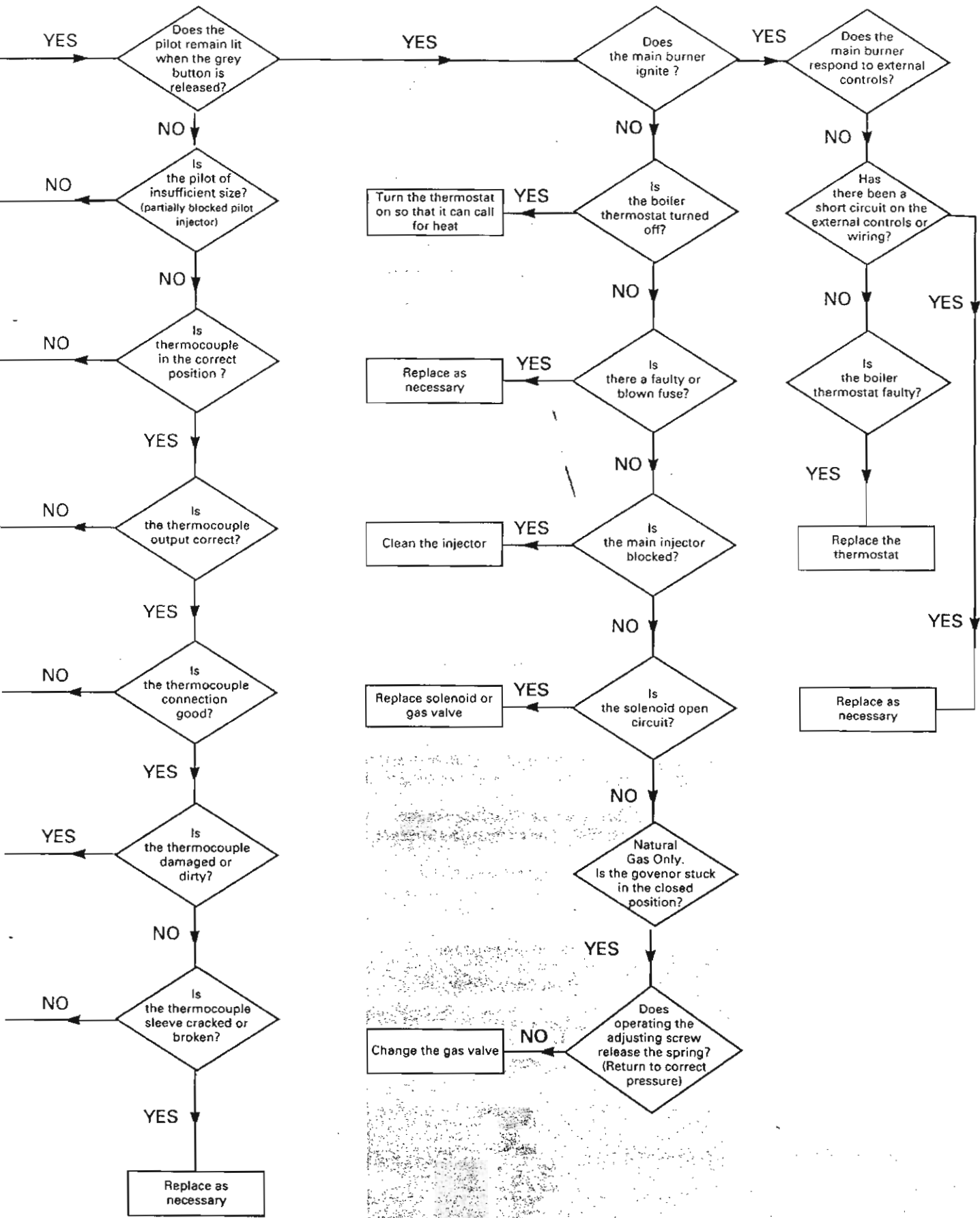

Baxi Heating is one of the leading manufacturers of domestic heating products in the U.K.

Our first priority is to give a high quality service to our customers. Quality is built into every Baxi product - products which fulfil the demands and needs of modern consumers, offering choice, efficiency and reliability.

To keep ahead of changing trends, we have made a commitment to develop new ideas using the latest technology - with the aim to continue making the products that customers want to buy.

Baxi is also the largest manufacturing partnership in the country. Everyone who works at the company has a commitment to quality because, as shareholders, we know that satisfied customers mean continued success.

We hope you get a satisfactory service from Baxi. If not, please let us know.

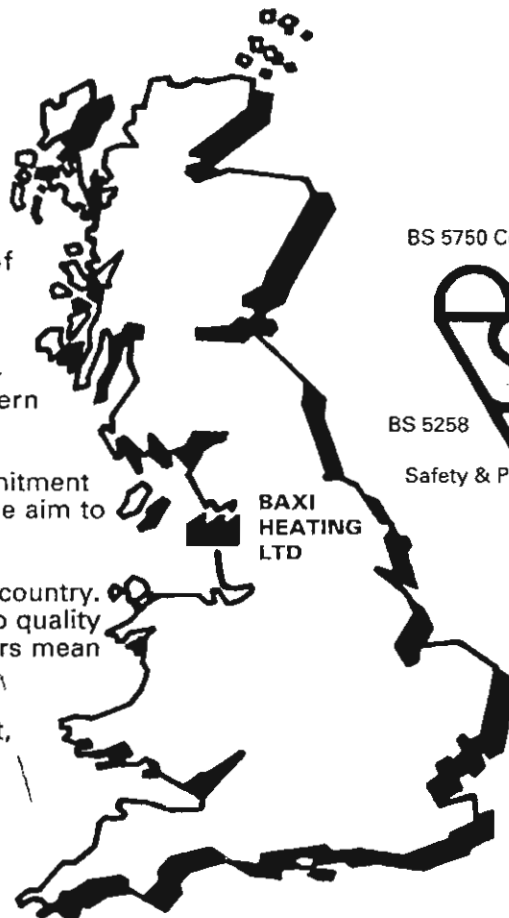

BS 5750 Company



BS 5258

BS 6332

Safety & Performance

---

## CUSTOMER CARE

---

After Sales Service Tel N°: 01772 695505 (Fax N°: 01772 695421) Technical Information Tel N°: 01772 695504

Baxi Heating manufacture a comprehensive range of products for the domestic heating market

**Gas Central Heating Boilers**  
(Wall, Floor and Fireside models).

**Independent Gas Fires.**

**Renewal Firefronts**

**Gas Wall Heaters.**

**Solid Fuel Fires**

If you require information on any of these products, please write to the Sales Department at the address below.



**Baxi Heating Limited**

Brownedge Road Bamber Bridge Preston Lancashire PR5 6SN

Main Switchboard 01772 695555 Order Office 01772 695454 Literature Office 01772 695500 Facsimile 01772 695410



# BAXI BERMUDA

## SP / VP

### FIRESIDE GAS CENTRAL HEATING UNITS

### USER'S OPERATING INSTRUCTIONS FOR NATURAL GAS, RENEWAL & PROPANE

Features of the  
Baxi Bermuda Gas Central Heating Units

- \* As market leader the Baxi Bermuda provides central heating to over-1½ million homes in the U.K.
- \* Solves the problem of where to site the central heating boiler by using wasted chimney space.
- \* Superb living flame effect with high efficiency.
- \* Gently angled three sided glass allows all round viewing of the living flames.
- \* Fires feature electronic ignition and independent illumination.

Please keep these instructions safe.  
Should you move house, please hand them over to the next occupier.

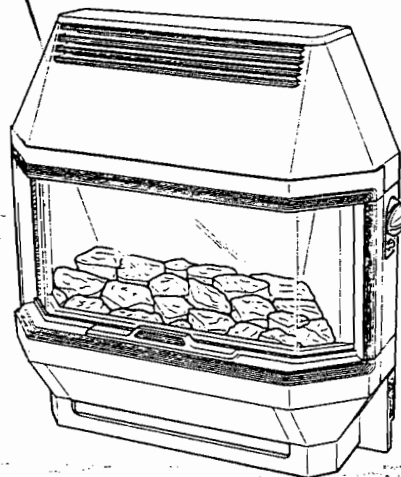

**BAXI BERMUDA SP**

G.C. N° 37 077 18

**RENEWAL**

G.C.N° 156 099

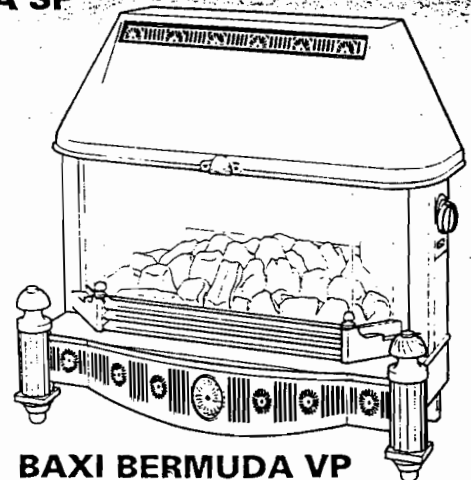

**BAXI BERMUDA VP**

G.C. N° 37 077 17

**RENEWAL**

G.C.N° 156 099

**BAXI**  
HEATING

# OPERATING YOUR BERMUDA SP/VP

## IMPORTANT NOTICE

The Bermuda SP/VP Propane appliances are for use on **PROPANE GAS ONLY** and cannot be used on any other gas.

## WARNING

Bermuda SP/VP Renewal Firefronts **MUST** never be fitted as independent gas fires without the boiler.

BS 5750 Company



BS 5258 BS 6332

Safety & Performance

*Baxi Heating is one of the leading manufacturers of domestic heating products in the U.K.*

*Our first priority is to give a high quality service to our customers. Quality is built into every Baxi product - products which fulfil the demands and needs of modern consumers, offering choice, efficiency and reliability.*

*To keep ahead of changing trends, we have made a commitment to develop new ideas using the latest technology - with the aim to continue making the products that customers want to buy.*

*Baxi is also the largest manufacturing partnership in the country. Everyone who works at the company has a commitment to quality because, as shareholders, we know that satisfied customers mean continued success.*

*We hope you get a satisfactory service from Baxi. If not, please let us know.*

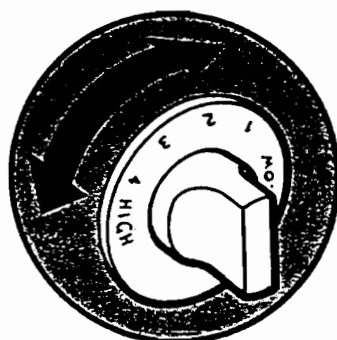
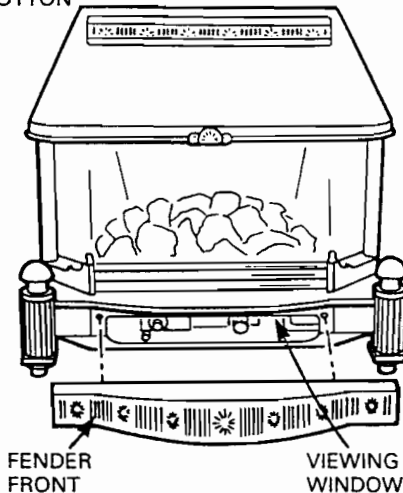
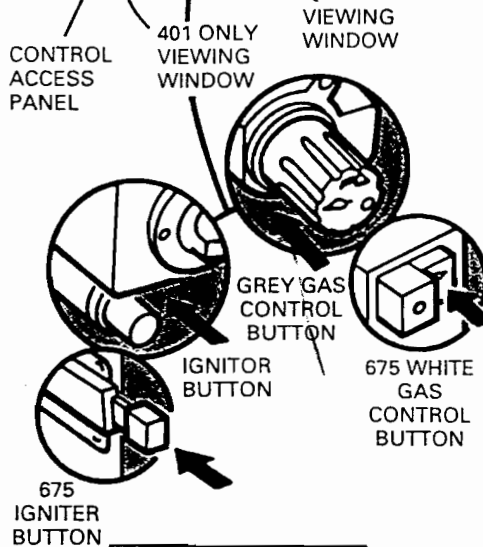
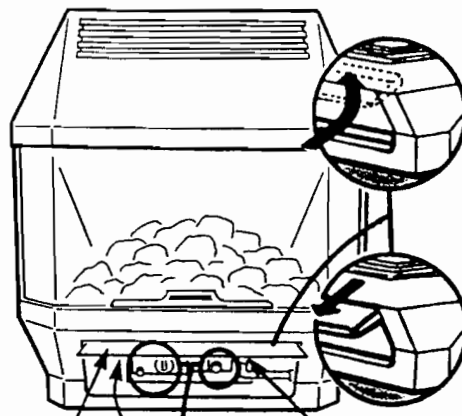

THERMOSTAT KNOB

**1** (Bermuda SP) Open the controls access panel by pushing forward at the bottom. Lift the panel and pull forward to fix in the open position.

(Bermuda VP) Remove the fender front at the bottom of the fire by pulling forward.

**2** Turn the boiler thermostat knob to the off position fully anti-clockwise.

**3** Turn on the main gas and electricity supplies to the appliance.

**4 TO LIGHT THE BOILER PILOT:** Press in and hold the grey gas control button (in the case of a 675 boiler - white control button). Looking through the pilot viewing window: Press in the igniter button and release. Repeat until the pilot ignites. Continue to hold in the gas control button for a further 15 seconds (in the case of a 675 boiler - 30 seconds) then release. The pilot should stay alight.

**NOTE:** If the pilot fails to remain alight or is extinguished at any time, wait 3 minutes then repeat the procedure from the start of "4 TO LIGHT THE BOILER PILOT". Once the pilot is alight it may be left on permanently.

**5 TO OPERATE THE BOILER:** Ensure that any external controls, e.g. room thermostat, cylinder thermostat, timer etc., are calling for heat. Turn the boiler thermostat knob clockwise to the desired position.

Setting 4 or High is normally used during the winter months. If the boiler is supplying domestic hot water only, setting 2 is normally used in the summer months.

**6 TO LIGHT THE FIRE:** Push in the control knob. Turn to the IGNITION position (⚡1) and hold. Sparking will commence and the fire will ignite. Continue to hold the control knob in position for a further 15 seconds then release. The fire should stay alight.

**NOTE:** If the fire fails to remain alight or is extinguished at any time, wait at least 2 minutes then repeat the procedure from the start of "6 TO LIGHT THE FIRE".

**CONTROL KNOB POSITIONS:** The control knob has five positions giving a choice of 4 settings, i.e.

- Position 0 - OFF
- Position ⚡1 - IGNITION/LOW
- Position 2 - MEDIUM
- Position 3 - MED/HIGH
- Position 4 - HIGH

To adjust the fire to the required setting, push in the control knob and turn in the appropriate direction.

**7 TO TURN THE FIRE OFF:** Push in the control knob and turn clockwise to the OFF position.

**NOTE:** When your Bermuda is first used it is possible that certain smells may be emitted. These smells will quickly disappear with use. As the fire is used more and more, the bright finished metal around the coal bed will begin to darken. This is perfectly normal and will enhance the realism of the coal and flame effect.

Most heating appliances generate warm air convection currents and transfer heat to any wall surface against which they are situated. Some soft wall furnishings (such as blown vinyl wallpapers) may not be suitable for use where they are subjected to temperatures above normal room levels and the manufacturer's advice should be sought before using this type of wall covering adjacent to any heating appliance. The likelihood of wall staining from convected air currents will be increased in environments where high levels of cigarette smoke or other contaminants exist.

## LIGHT EFFECT

The light effect is operated by a switch below the control knob and may be used either with or without the fire being on.

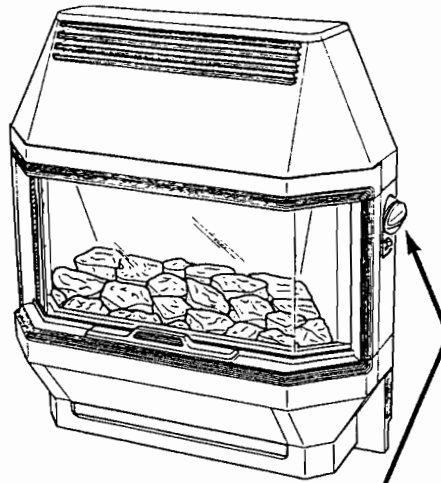

BAXI BERMUDA SP

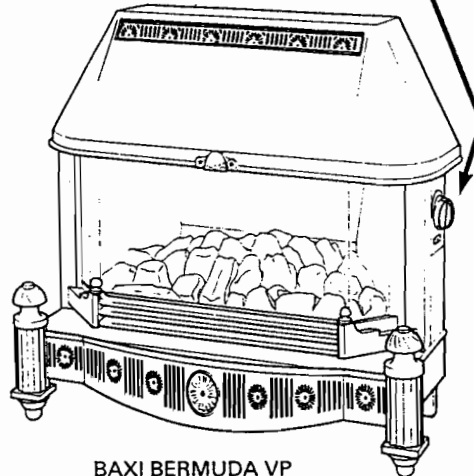

BAXI BERMUDA VP

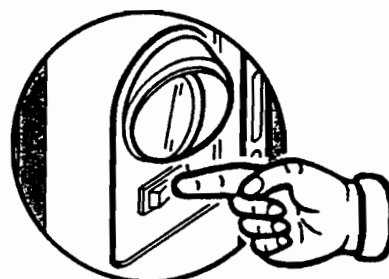

## TO SHUT DOWN THE BOILER

**1 (Bermuda SP)** Open the controls access panel by pushing forward at the bottom. Lift the panel and pull forward to fix in the open position.

**(Bermuda VP)** Remove the fender front at the bottom of the fire by pulling forward.

**2** Turn the boiler thermostat knob to the off position, i.e. fully anti-clockwise. This operation switches off the main boiler burner, but leaves the pilot alight.

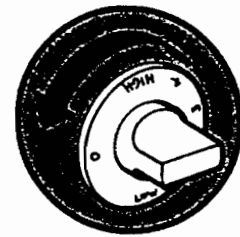

**3** To shut down the pilot, turn the grey gas control button clockwise and release (or in the case of a 675 boiler push in the red button).

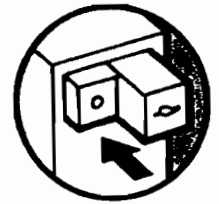

675 BOILER - RED GAS CONTROL BUTTON

Isolate the gas and electricity supplies to the boiler. Refit the the fender front or close the controls access panel.

**NOTE:** If your home is to be left unoccupied for long periods during cold weather, the whole heating system should be drained to avoid frost damage unless a frost-thermostat is fitted.

Your installer will advise you about draining the system.

## GUARDING

The glass front panel on this appliance conforms to the required safety standards. It does not give full protection to the young, elderly or infirm. Where such protection is required, use a fire-guard which conforms to BS 6539: 1984. The glass panel becomes very hot when the appliance is in use and must not be touched. The appliance must never be used without the glass panel in place.

## REMOVAL OF GLASS FRAME

Ensure that the fire is cold! and then remove the canopy following the appropriate instructions.

Remove the "Bermuda VP" canopy by gently easing the sides inwards and the bottom edge forward, then lift the canopy upwards and away from the locating lip. Open out the doors.

Remove the "Bermuda SP" canopy, firstly by opening the side doors, then lift the canopy by the bottom edge upwards and away from the locating lip.

Unlock the retaining clips fixing the glass frame in position and lift the frame away.

To replace the glass frame, place the bottom edge in the locating channel and push against the sealing rope. Engage the retaining clips. This ensures an effective seal between the glass frame and the fire front.

To replace the "Bermuda VP" canopy close the doors and re-locate the canopy on the locating lip and then by gently easing the sides inwards, push home to lock in place.

To replace the "Bermuda SP" canopy guide the bottom edge onto the door pins and then by tilting the back edge over the locating lip. Close the doors ensuring they lock in place.

**CAUTION!** This appliance must never be used without the glass frame in position. Should the glass front panel become damaged or cracked, the fire should be turned off until it has been replaced.

**NOTE:** This is a heat resistant glass and must not be replaced by ordinary glass. Some small blemishes may be seen in the glass. These are inherent in its manufacture and will not affect its performance or durability.

## IGNITION WITH A TAPER

In the event of an interruption to the electricity supply to your Bermuda, it is possible to light the fire using a taper or match. To do this, remove the glass frame as described above and apply the lighted taper or match to the lower right hand gap between the coals, whilst otherwise following the instructions ("TO LIGHT THE FIRE"). Once the fire is lit, replace the glass frame immediately.

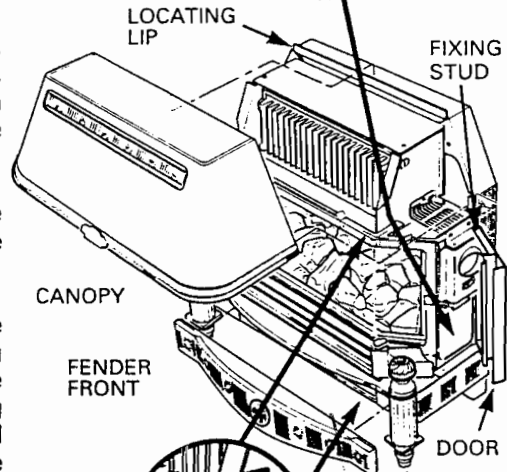
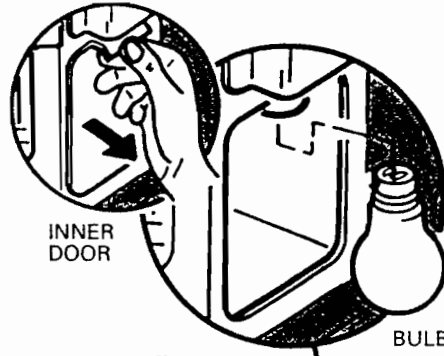

GLASS FRAME AND RETAINING CLIPS

PLUG AND SOCKET

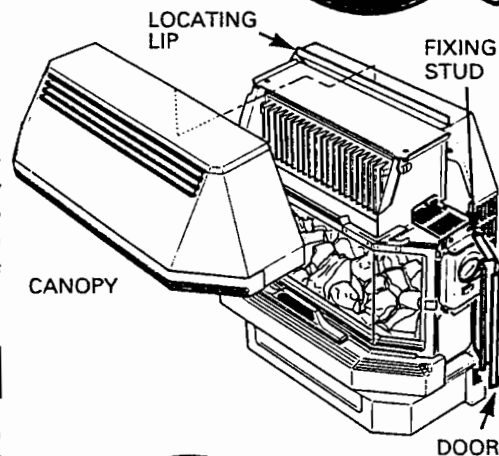

## REPLACING THE BULBS

The bulbs which provide artificial illumination for the fire are situated in special compartments behind the doors which open as shown in the illustration.

Ensure that the fire and bulbs are cold!

For safety reasons, isolate the electricity supply by disconnecting the plug from the socket, as shown.

Open out the doors as shown in the illustration.

Remove the inner door to gain access to the bulbs by grasping the lip and pulling firmly on it. The bulbs may now be replaced.

**NOTE:** For the best visual effect the fire is fitted with standard 40 W orange bulbs, but if desired can be replaced with other bulbs up to a maximum of 60 W.

To replace the inner doors, engage the bottom edge in position in the bulb housing and push home, ensuring that the spring clip locks in place.

Close the outer doors and reconnect the plug into the socket.

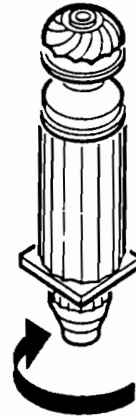

**NOTE:** If necessary the adjustable feet may be raised or lowered to touch the fireplace hearth by turning in the appropriate direction.

## CLEANING THE FIRE

Ensure that the fire is cold! The painted panels and metalwork should be wiped with a damp cloth and dried thoroughly with a lint-free cloth (a cloth without any loose fibres). Do not use a silicone based polish on any part of the fire. The glass may be cleaned with a cream cleanser. Clean the glass regularly for best results.

**NOTE:** Both sides of the glass must be cleaned after the first week of using the fire.

## RESTRICTED ACCESS: REPLACEMENT OF BULBS

In certain installations (i.e. where the clearances to the sides of the fire are less than 100mm (4in.)) it is necessary to remove the side doors to gain access to the bulbs, should they ever need changing.

This is done by first of all removing the canopy as described on the next page (under "REMOVAL OF GLASS FRAME").

Remove the side doors by opening them out and lifting away from the fixing studs shown in the illustration on the next page. The bulbs may now be replaced as described in the relevant section. ("REPLACING THE BULBS")

## SPARE PARTS

Any repairs to the appliance will usually be the responsibility of the installer during the guarantee period, after which spare parts may be obtained through approved Baxi stockists if required.

Quote the appliance name, model number, G.C. number and where possible, the part number, when ordering spares. (This information may be found on the appliance data badge which is situated on the inner fire support feet or in the appliance Installation and Servicing Instructions.)

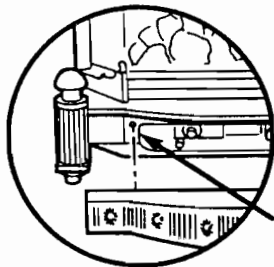

Data Label

The minimum clearance spaces around the Baxi Bermuda SP are:

Top: 76mm (3 in)  
Sides: 100mm (4 in)

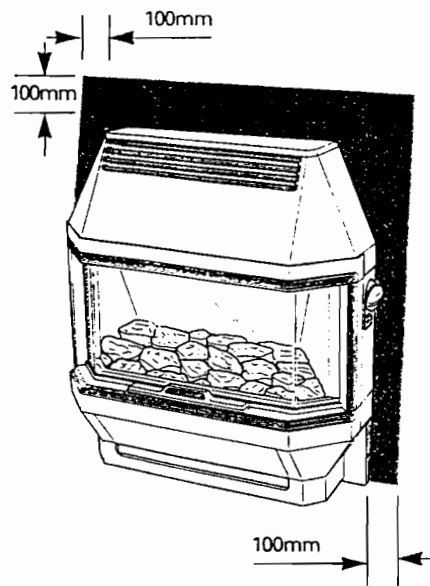

The minimum clearance spaces around the Baxi Bermuda VP are:

Top: 76mm (3 in)  
Sides: 100mm (4 in)

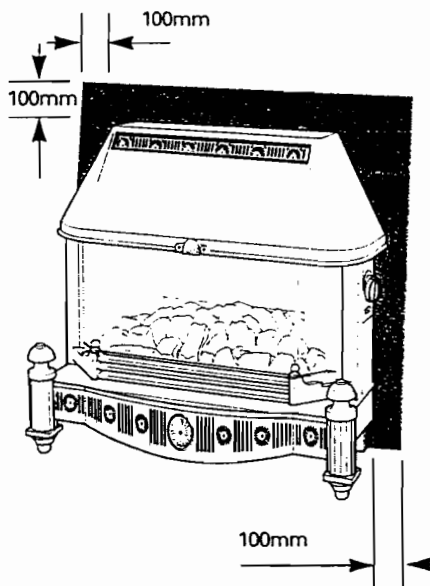

## CLEARANCES AROUND THE FIRE

These clearances must not be reduced or obstructed in any way.

Reducing the clearances above the fire may lead to damage to any overhanging shelf or fire surround by overheating. Reducing the clearances to the sides of the fire means that access to the control knob is reduced and it becomes impossible to replace the bulbs as described in the text "REPLACING THE BULBS". (See RESTRICTED ACCESS: REPLACEMENT OF BULBS.)

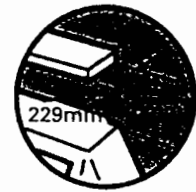

A shelf may be fitted at least 76mm (3 in) above the fire and not more than 229mm (9 in) in depth.

## Warnings

### IN CASE OF GAS LEAKS

If a gas leak is found or suspected, turn off the gas supply at the meter immediately and contact your Installer or British Gas Region Emergency Service (under 'Gas' in the phone directory).

**NEVER HANG CLOTHES OR OTHER ITEMS OVER THE APPLIANCE.**

### SERVICING YOUR BERMUDA

We strongly recommend that your Bermuda is serviced annually for economic and safety reasons. Your Installer or local Gas Region will be able to advise you.

### THIS APPLIANCE MUST BE EARTHED

Electricity supply: A standard 240 volt ~ 50Hz supply is required. The appliance must be protected by a 3 amp fuse.

### SAFE INSTALLATION

Installation of this appliance must be carried out by a competent person and be in accordance with the relevant requirements of the GAS SAFETY (Installation and Use) REGULATIONS: 1984, CURRENT I.E.E. WIRING REGULATIONS and any other regulations applying in your area.

PLEASE COMPLETE THE GUARANTEE CARD

# GUARANTEE

## WE ARE NOT HAPPY UNLESS YOU ARE

Your Baxi Bermuda is designed and produced to meet all the relevant British Standards.

Baxi Heating provide a 12 month guarantee on the Bermuda - other parts of the system are covered by the Installer or other manufacturers. The guarantee operates from the date installation is completed for the customer who is the original user.

To maximise the benefit from our guarantee we urge you to return the reply-paid guarantee registration.

This does not in any way prejudice your rights at Common Law. Such rights between the customer and the installer or supplier from whom the unit was purchased remain intact.

**Any component or part (with the exception of the bulbs) which becomes defective during the guarantee period as a result of faulty workmanship or material whilst in normal use will be repaired or replaced free of charge.**

BAXI HEATING LTD manufacture a comprehensive range of products for the domestic heating market

**Gas Central Heating Boilers**  
(Wall, Floor and Fireside models).

**Independent Gas Fires.**

**Renewal Firefronts.**

**Gas Wall Heaters.**

**Solid Fuel Fires.**

If you require information on any of these products, please write to the Sales Department at the address below.

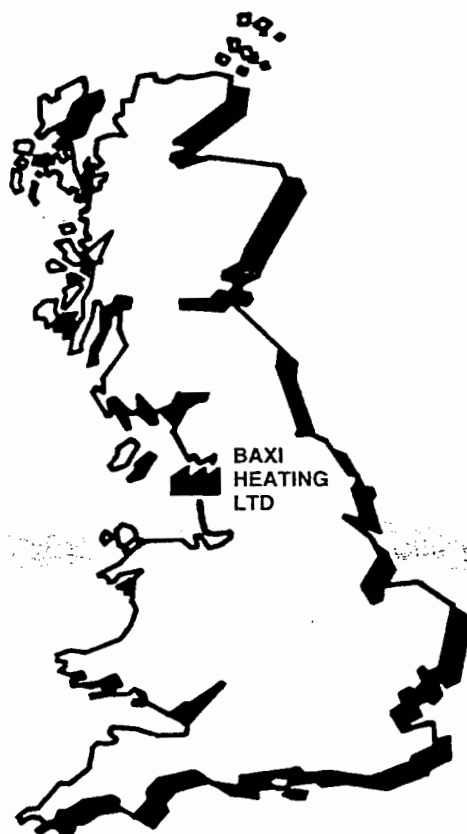

### CUSTOMER CARE

After Sales Service Tel N°: 01772 695505 (Fax N°: 01772 695421) Technical Information Tel N°: 01772 695504



Comp N° 232834 - 10/94

Baxi Heating Limited

Brownedge Road Bamber Bridge Preston Lancashire PR5 6SN

Main Switchboard 01772 695555 Order Office 01772 695454 Literature Office 01772 695500 Facsimile 01772 695410